



**THE DATASHEET OF**  
**7012X5**





### 7012X Series Bright Chips SMT LEDs 0805 Package Size

Our miniature chip-type LEDs offer premium brightness in a compact design, ideal for telecommunications, data processing, and backlighting.

## General Information

- Premium brightness in miniature chip-type LED assemblies
- Ideally suited for applications such as telecommunications, data processing for through-hole products
- Also ideal for backlighting or light pipe applications
- Compact size: 2mm wide x 1.25mm deep x 1mm high
- 4,000 pieces per reel for Red and green, and 3,000 for Yellow-Green
- Integral reflection cup maximizes output
- Compatible with full range of IR and vapor phase reflow processes, and conductive adhesives, to facilitate high-speed board loading
- Packaged for automatic component placement in pocketed anti-static tape reels
- Resin Color: Milky White
- Die Material: AlGaInP
- REACH and RoHS Compliant



Part Number	7012X1	7012X5	7012X7
Output Color	Red	Green	Yellow-Green
Diffusion	Diffused	Diffused	Diffused
Package Color	Clear	Clear	Clear
Test Current (mA)	20	20	20
Forward Voltage Typ. (V)	1.9	1.9	2.0
Forward Voltage Max. (V)	2.4	2.4	2.4
Luminous Intensity Min. (mcd)	-	10	22.0
Luminous Intensity Typ. (mcd)	91	-	31.0
Luminous Intensity Max. (mcd)	120	22	-
Peak Wavelength (nm)	635	565	575
Viewing Angle 2 $\theta$ 1/2 (degrees)	140	160	140
Power Dissipation (nW)	78	78	60
Operating Temperature (°C)	-40~+100	-40~+100	-40 to+85
Storage Temperature (°C)	-40~+105	-40~+105	-40 to+90
Peak Forward Current Max. (1 $\mu$ s @ 10% duty cycle) (mA)	100	100	60
Reverse Voltage (IR=100 $\mu$ A) (V)	5	5	5
Lead Solder Time @ 260° C	5	5	5



## Product Dimensions

Unit: mm  
 Weight: 2.84mg  
 Tolerance: ±0.1

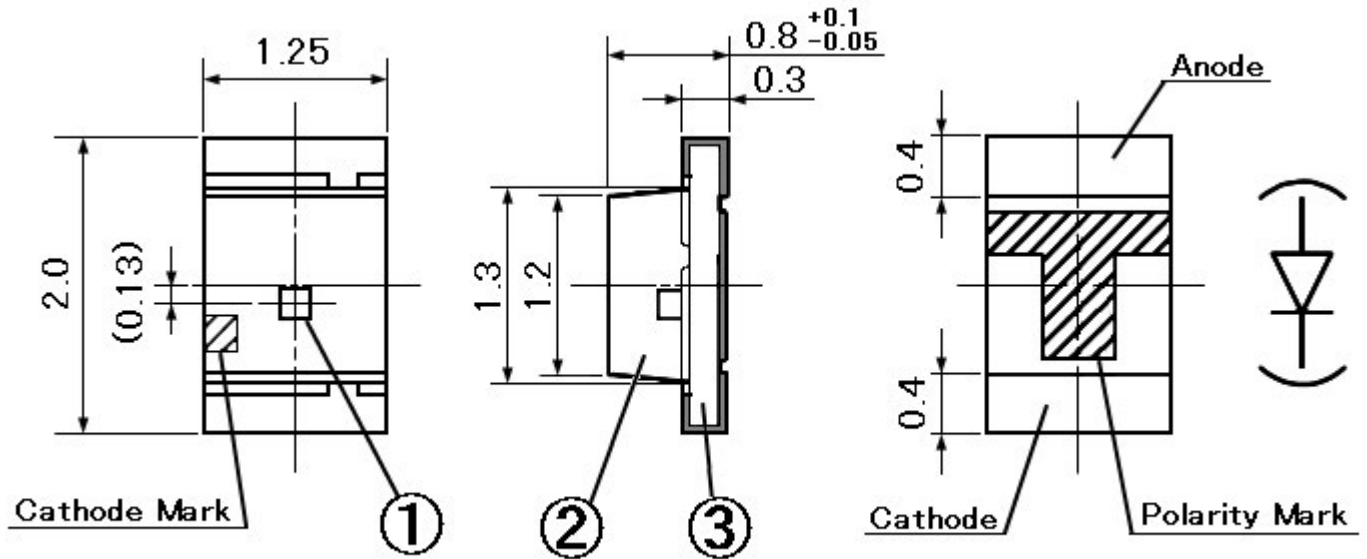

SYMBOL	PART NAME	MATERIAL	QTY.
①	LED Die	AlGaInP	1
②	Lens	Epoxy Resin	1
③	Substrate	Glass Fabrics	1

## Recommended pad

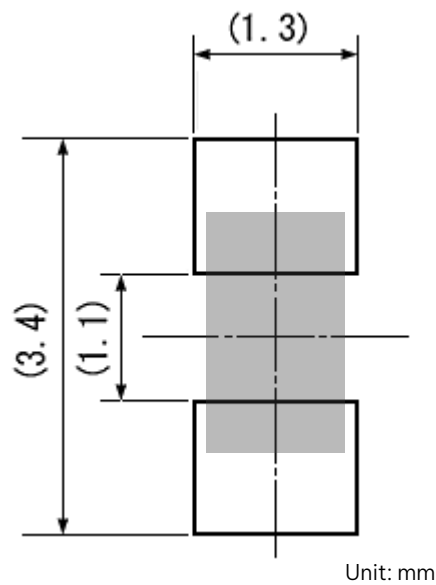



# Technical Data

7012X5  
Green

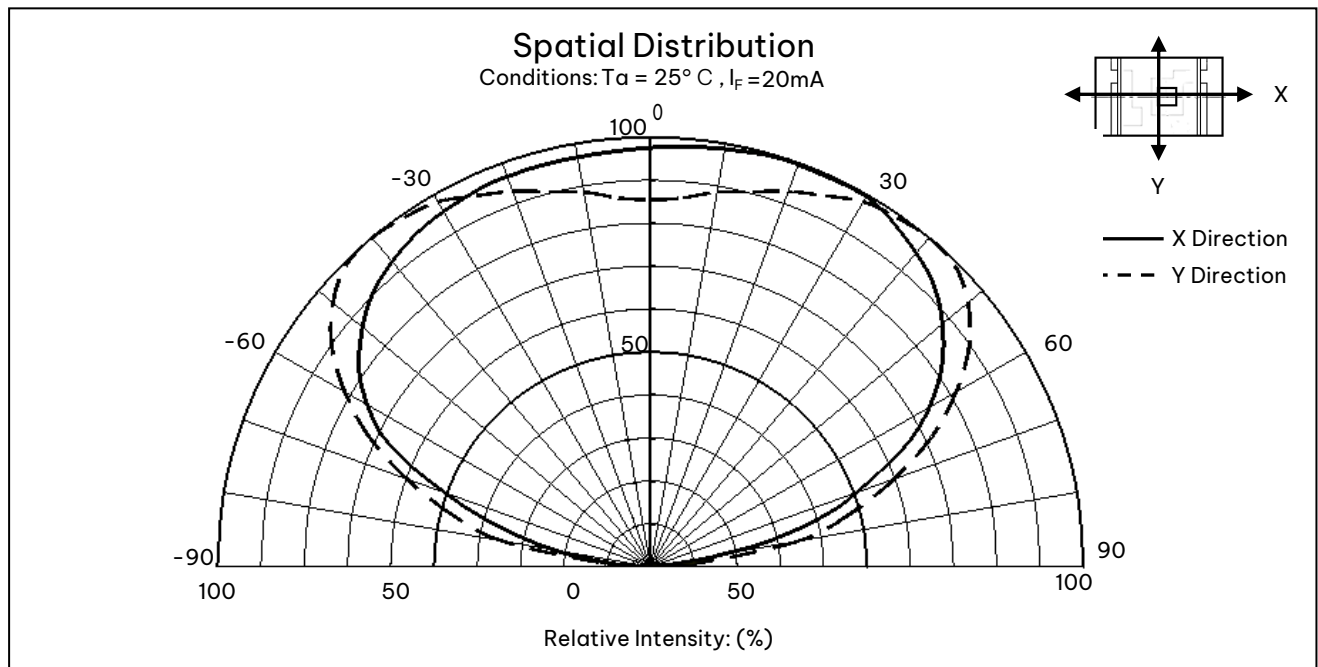
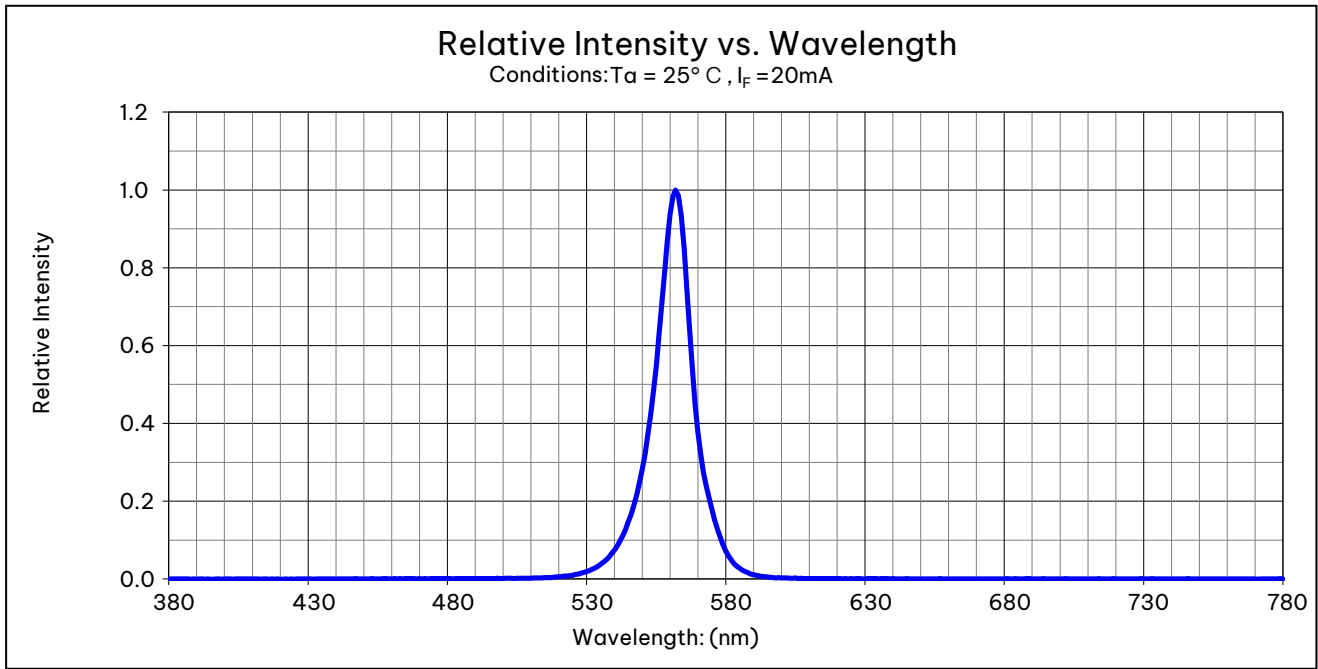



# Technical Data

7012X5  
Green

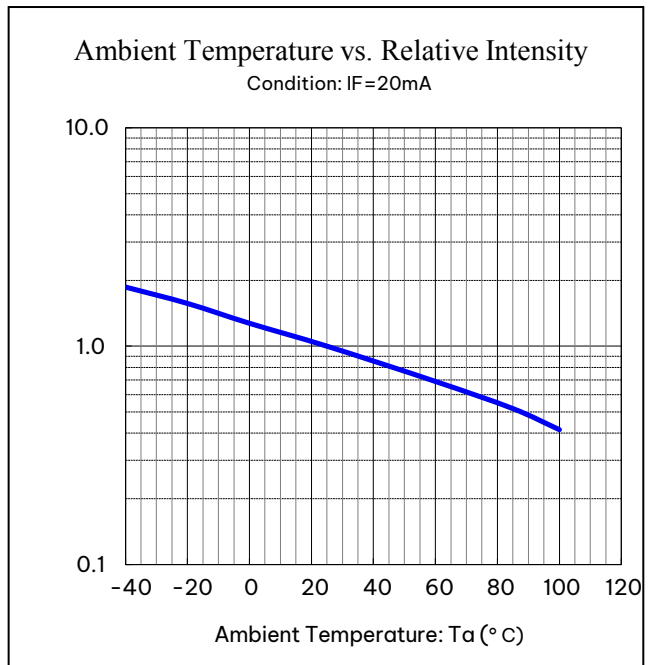
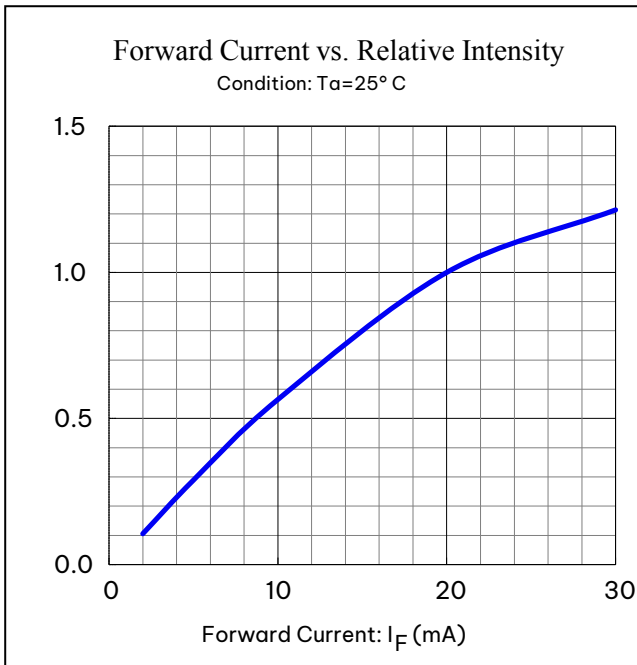
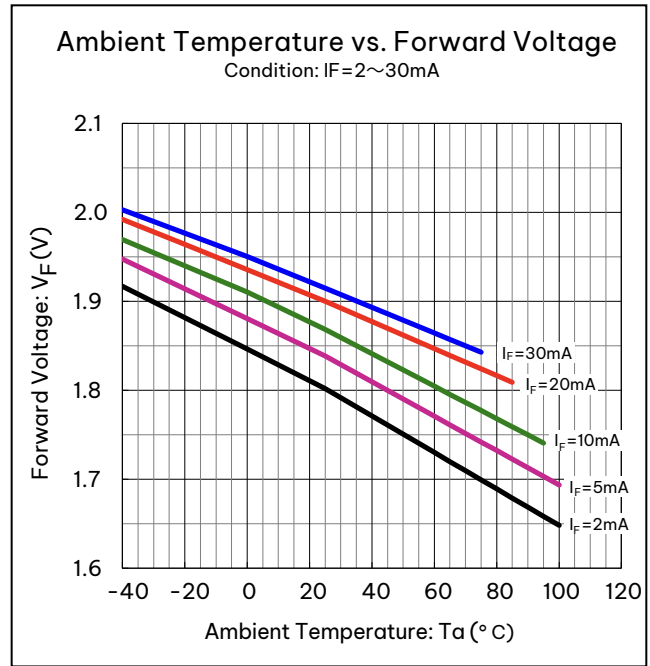
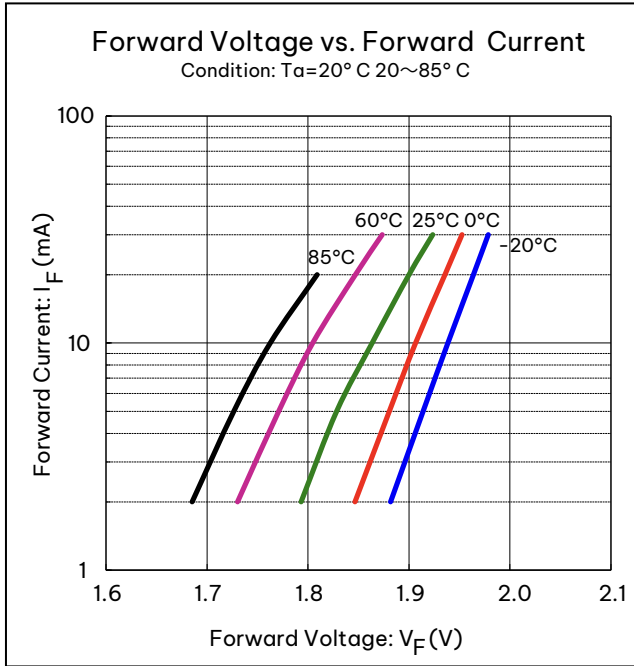



# Technical Data

7012X5  
Green

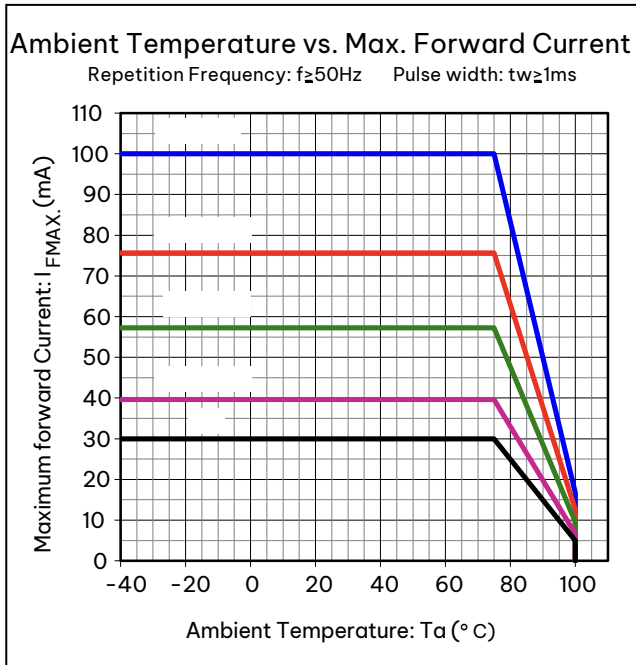
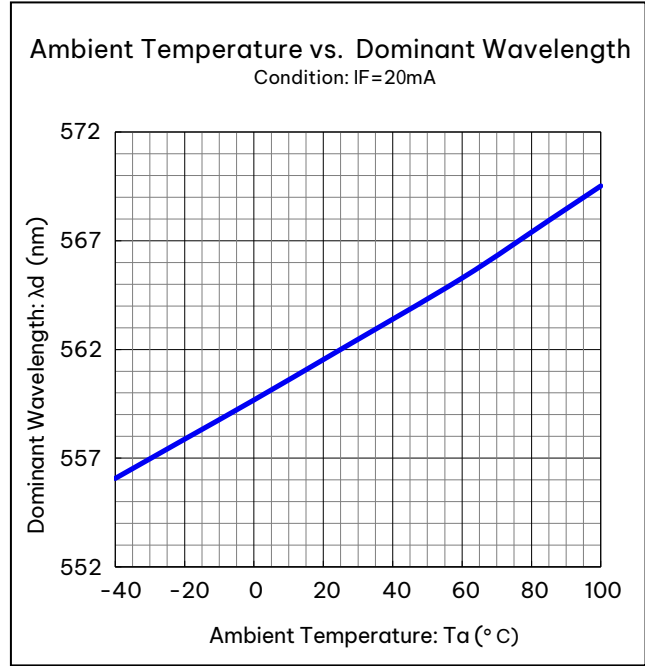
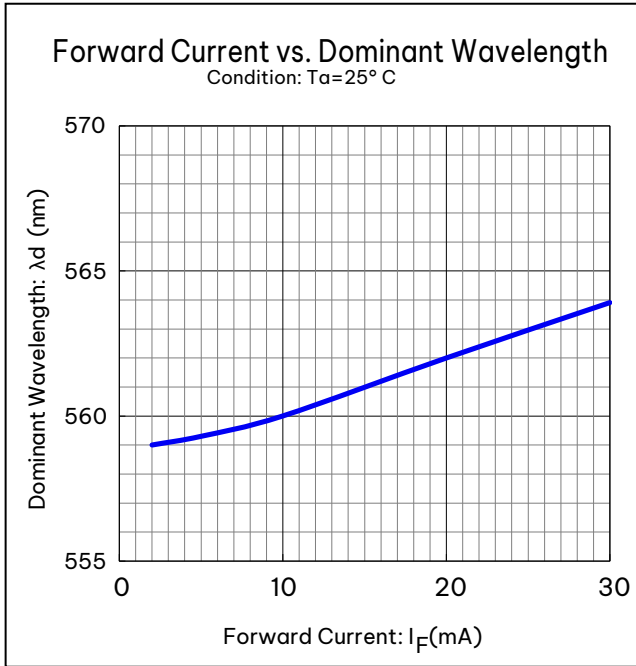



# Technical Data

7012X1  
Red

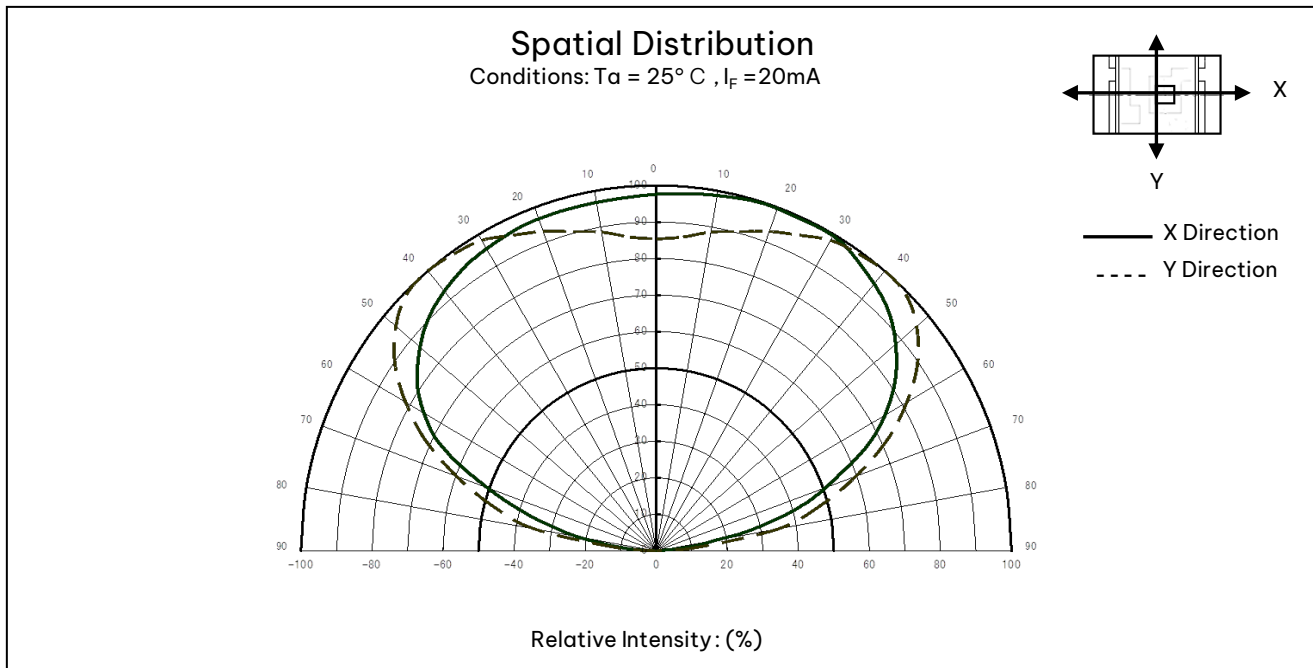
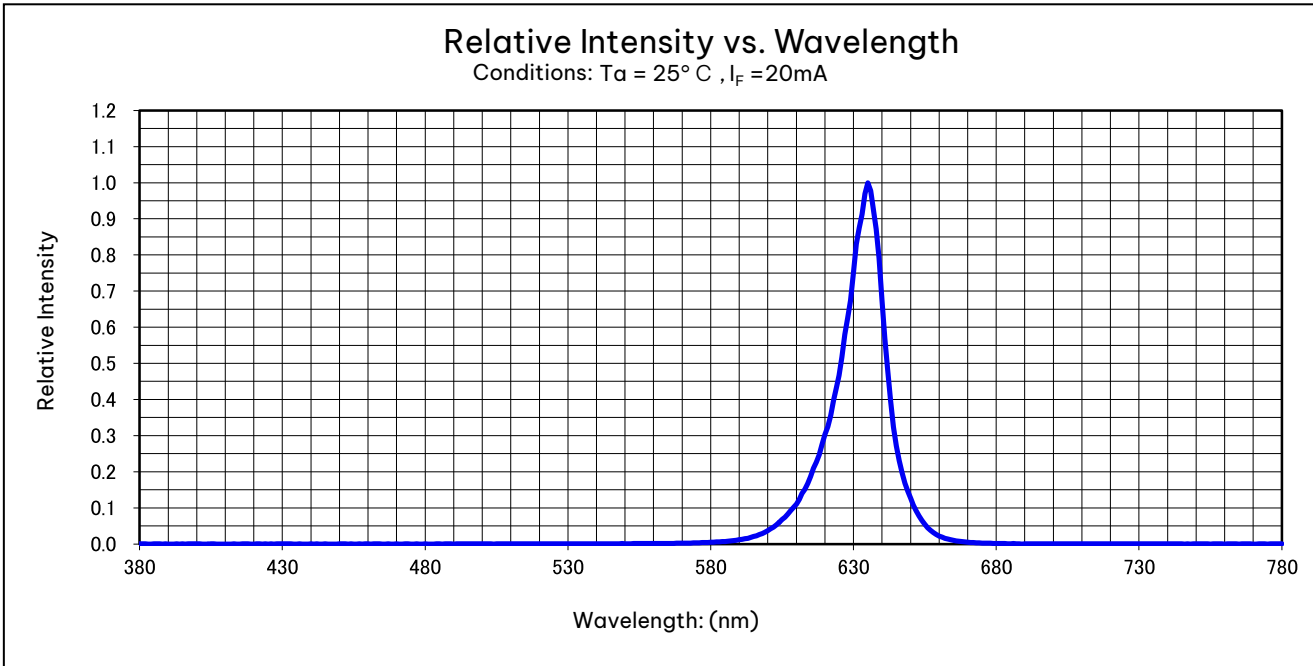



# Technical Data

7012X1  
Red

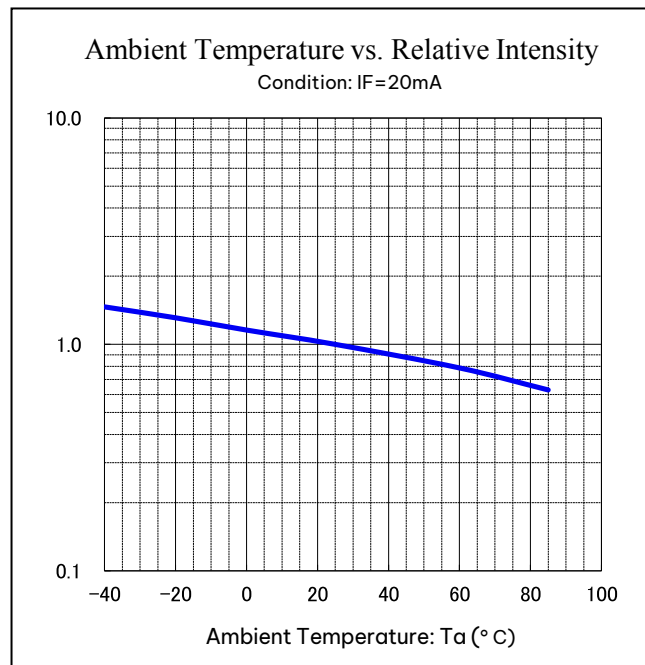
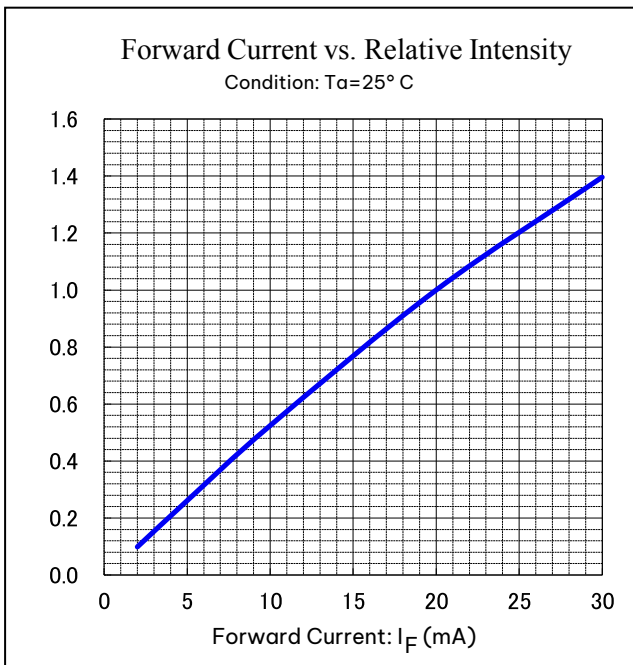
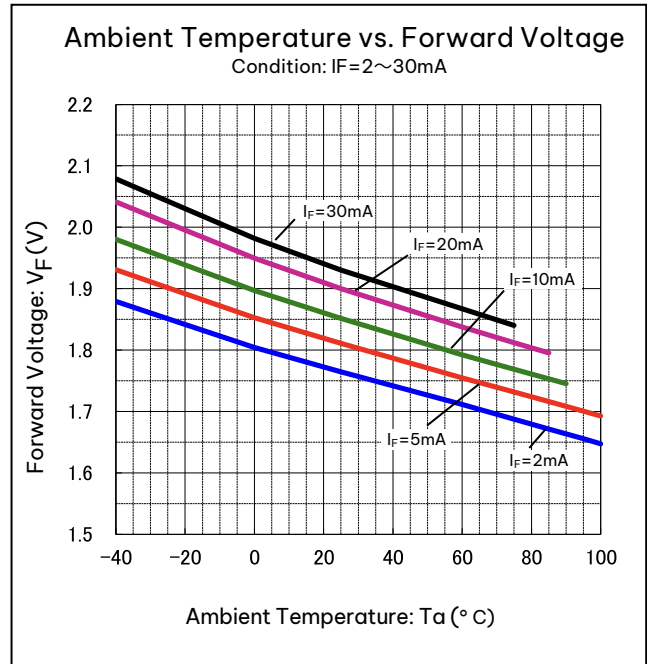
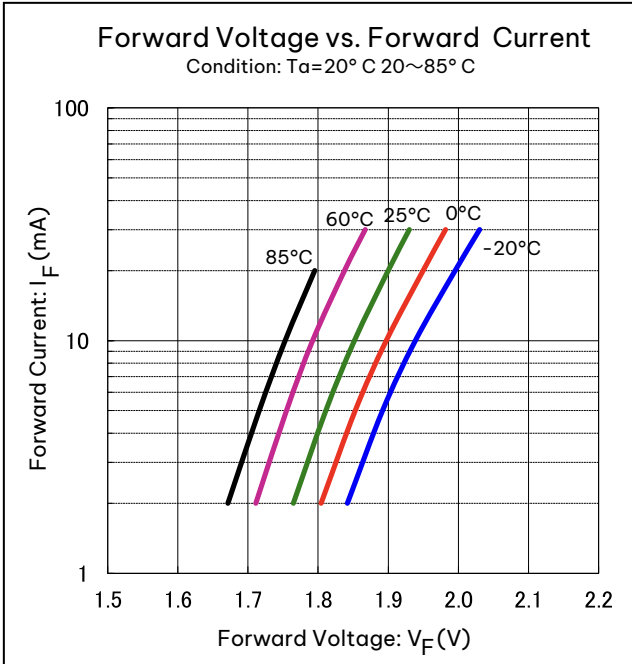



# Technical Data

7012X1  
Red

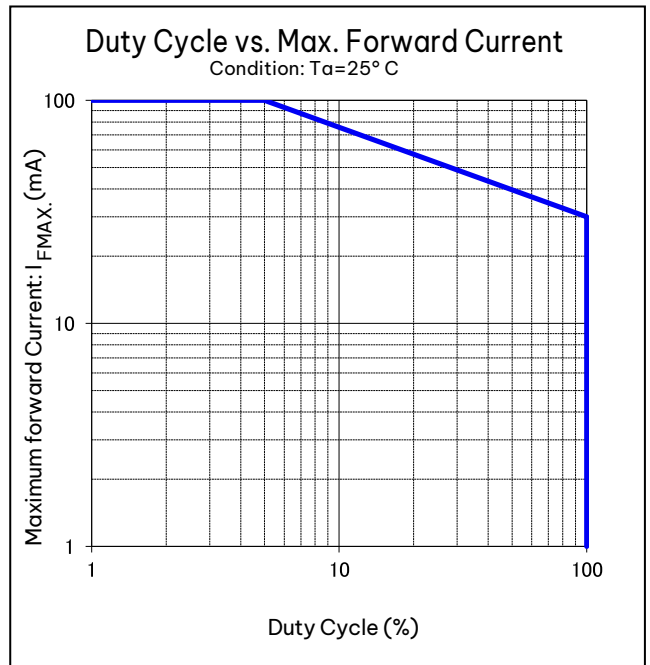
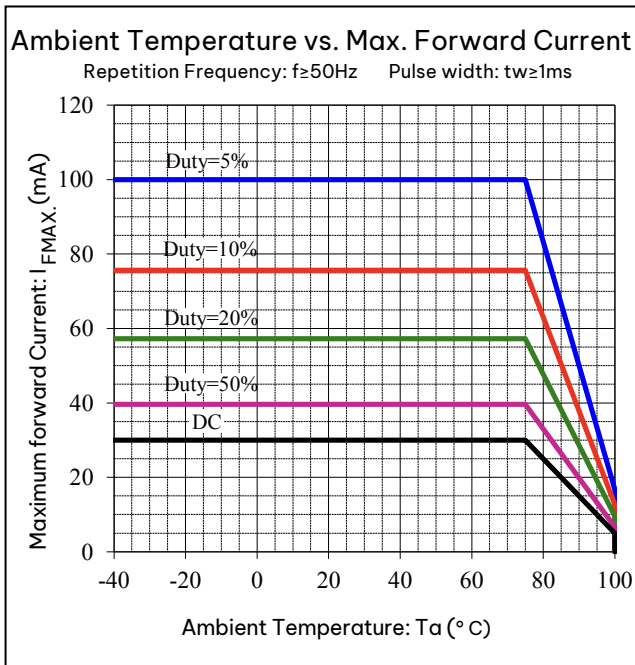
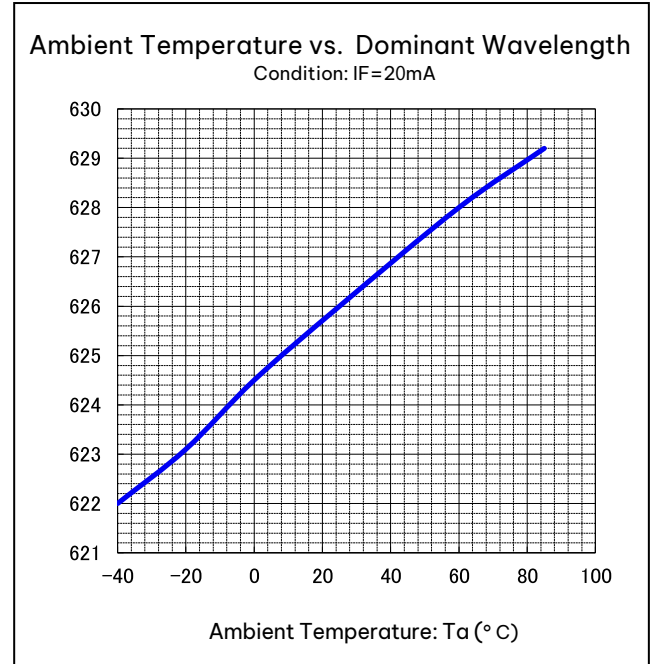
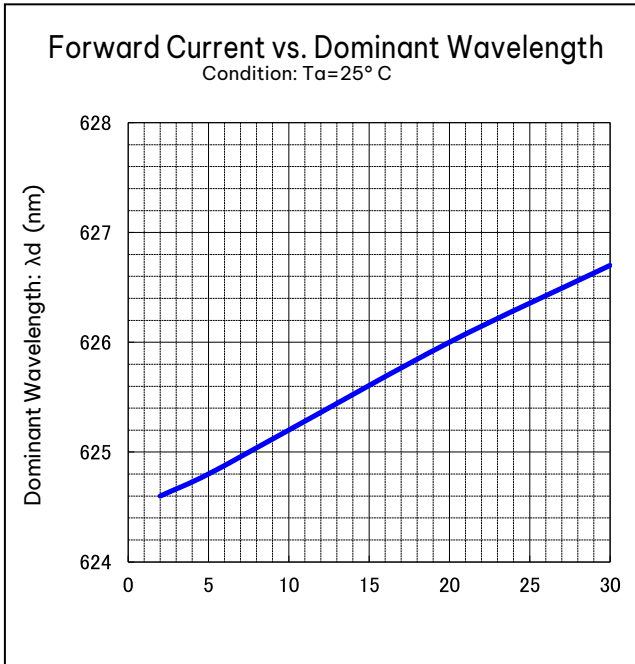



# Technical Data

7012X7  
Yellow-Green

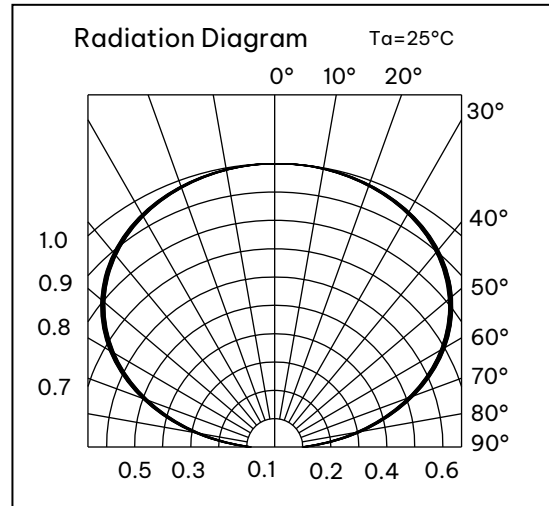
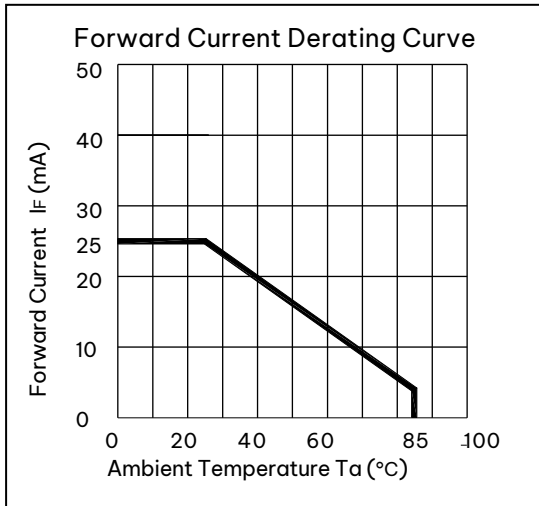
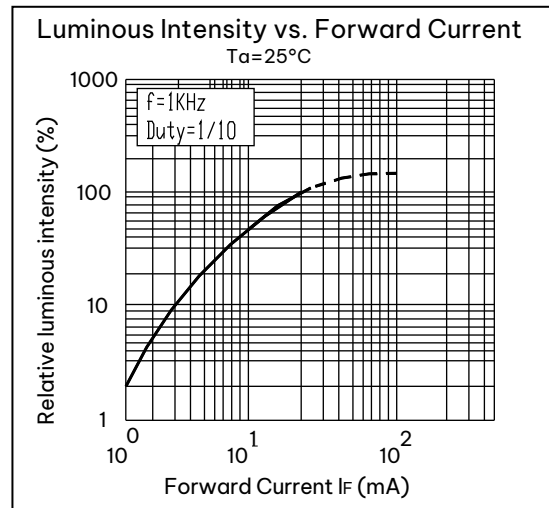
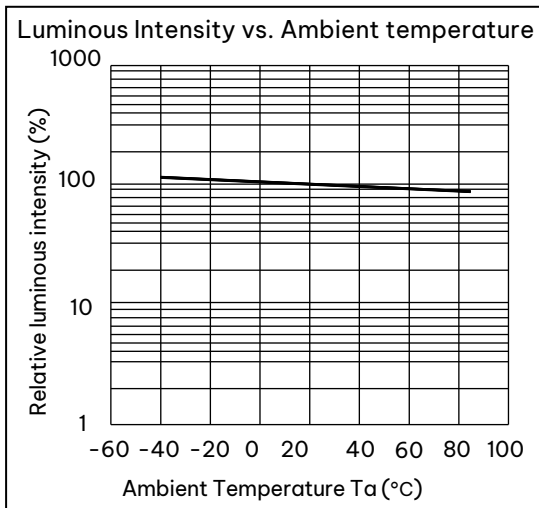
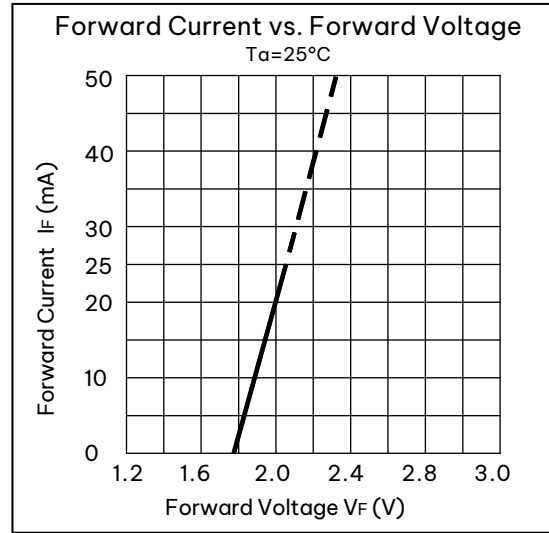
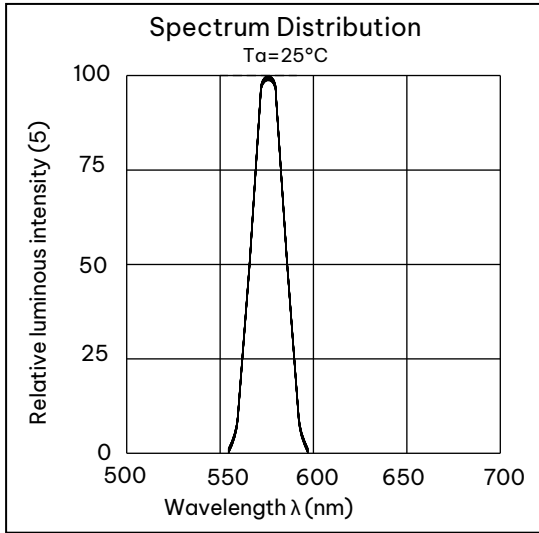



## Soldering Condition

1. Heat stress during soldering will influence the reliability of LEDs, however that effect will vary on heating method. Also, if components of varying shape are soldered together, it is recommended to set the soldering pad temperature according to the component most vulnerable to heat (e.g., surface mount LED).
2. LED parts including the resin are not stable immediately after soldering (when they are not at room temperature), any mechanical stress may cause damage to the product. Please avoid such stress after soldering, especially stacking of the boards which may cause the boards to warp and any other types of friction with hard materials.
3. Recommended temperature profile for the Reflow soldering is listed as the temperature of the resin surface.
4. Temperature distribution varies on heating method, PCB material, other components in the assembly, and mounting density .

Please do not repeat the heating process in Reflow process more than twice.

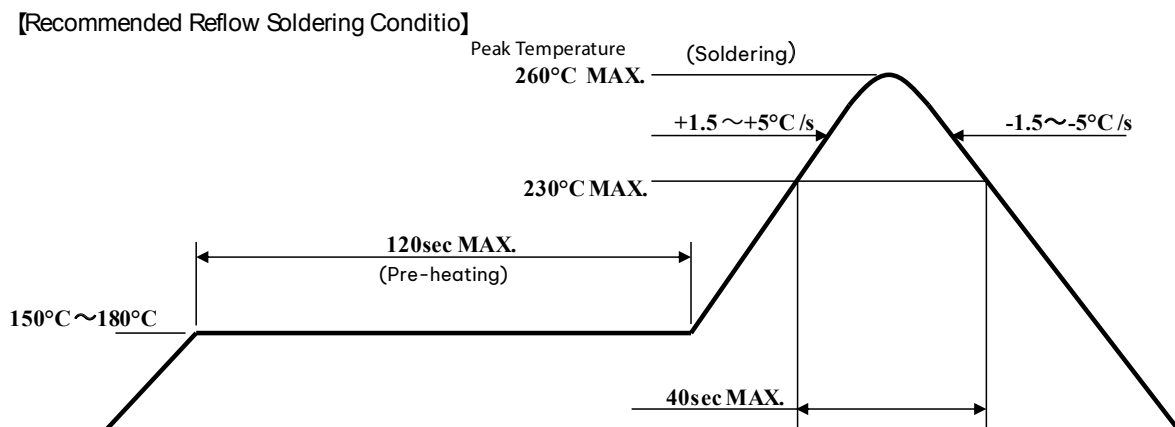

### Notes:

1. Temperature Profile for the reflow should be set to the surface temperature of resin which is on the of LED. This should be the maximum temperature for soldering. Lowering the heating temperature and decreasing heating time is very effective in achieving higher reliability.
2. The reflow soldering process should be done up to twice (2 times Max). When second process is performed, interval between first and second process should be as short as possible to prevent absorption of moisture to resin of LED. The second soldering process should not be done until LEDs have returned to room temperature (by nature-cooling) after first soldering process.



## Soldering Condition

- If soldering manually, VCC recommends using a soldering iron equipped with temperature control. During the actual soldering process, make sure that the soldering iron never touches the LED itself, and avoid the LED's electrode heating temperature reaching above the heating temperature of the solder pad. All repairs must be performed only once in the same spot, and please avoid reusing components.
- In soldering process, immediately after iron tip is cleaned, please make sure that the soldering iron reaches the appropriate temperature, before using. Also, please avoid applying any types of pressure to the soldered components before the solder has been cooled and hardened, as it may deteriorate solder performance and solder quality.

### [Recommended Manual Soldering Condition]

Temperature of Iron Tip	350°C MAX.
Soldering Duration, Time	3sec.Max.,1 time

- When using adhesive material for tentative fixatives, thermosetting resin or Ultraviolet radiation (UV) setting resin with heat shall be recommended.

The curing condition, Temperature: 150°CMax./Time: 120sec.Max.

- Isopropyl alcohol is recommended for cleaning. Some chemicals, including Freon substitute detergent could corrode the lens or the casing surface, which cause discoloration, cloud, crack and so on. Please review the reference chart below for cleaning. If water is used to clean (including the final cleaning process), please use pure water (not tap water), and completely dry the component before using.

Chemical	Adaptability
Ethyl Alcohol	○
Isopropyl Alcohol	○
Pure Water	○
Trichloroethylene	X
Chloroethene	X
Acetone	X
Thinner	X



## Handling Precaution

1. VCC LED Lamps have semiconductor characteristics and are designed to ensure high reliability. However, the performance may vary depending on usage conditions.
2. Absolute Maximum Ratings are set to prevent LED lamps from failing due to excess stress( temperature, current, voltage, etc.). Usage conditions must not exceed the ratings for a moment, nor do reach one item of absolute maximum ratings simultaneously.
3. In order to ensure high reliability from LED Lamps, variable factors that arise in actual usage conditions should be taken it to account for designing. ( Derating of TYP., MAX Forward Voltage, etc.)
4. Please insert protective Resistors into the circuit in order to stabilize LED operation and to prevent the device from igniting due to excess current.
5. Please check the actual performance in the assembly because the Specification Sheets are described for LED device only.
6. Please refrain from looking directly at the light source of LED at high output, as it may harm your vision.
7. The products are designed to operate without failure in recommended usage conditions. However, please take the necessary precautions to prevent fire, injury, and other damages should any malfunction or failure arise.
8. The products are manufactured to be used for ordinary electronic equipment. Please contact our sales staff beforehand when exceptional quality and reliability are required, and the failure or malfunction of the products might directly jeopardize life or health ( such as for airplanes, aerospace, transport equipment, medical applications, nuclear reactor control systems and so on).
9. The formal specification sheets shall be valid only by exchange of documents signed by both parties.



## Packaging Specifications

This product is baked (moisture removal) before packaging, and is shipped in moisture-proof packaging (as shown below) to minimize moisture absorption during transportation and storage. However, with regard to storing the products, VCC recommends the use of dry-box under the following conditions is recommended. Moisture-proof bag as the packaging is made of anti-static material but packaging box is not.

[Recommended Storage Condition / Products Warranty Period ]

Temperature	+5-30°C
Humidity	Under 70%

In the case of the package unopened , 6 months under, 6 months under [Recommended Storage Condition ].

Please avoid rapid transition from low temp. condition to high temp. condition and storage in corroding and dusty environment.

[Time elapsed after Package Opening]

The package should not be opened until immediately prior to its use, and please keep the time frame between package opening and soldering which is [maximum 168h].

If the device needs to be soldered twice, both soldering operations must be completed within the 168h.

If any components should remain unused, please reseal the package and store them under the conditions described in the [Recommended Storage Condition] above.

This product must be required to perform baking process (moisture removal) for at least 10h and not exceed for 12h at  $60 \pm 5$  degrees Celsius if following conditions apply.

1. In the case of silica gel (blue) which indicates the moisture level within the package, changes or loses its blue color.
2. In the case of time passes for 168h after the package is opened once.

Baking process should be performed after LED having been taken out of the package.

Baking may be performed in the tape-reel form , however if it is performed with the reel stacked over one another, it may cause deformation of the reels and taping materials and later obstruct mounting. Please handle only once it has returned to room temperature. Provided that, baking process shall be 2 times MAX.



# Taping and Reel Specifications

## Appearance

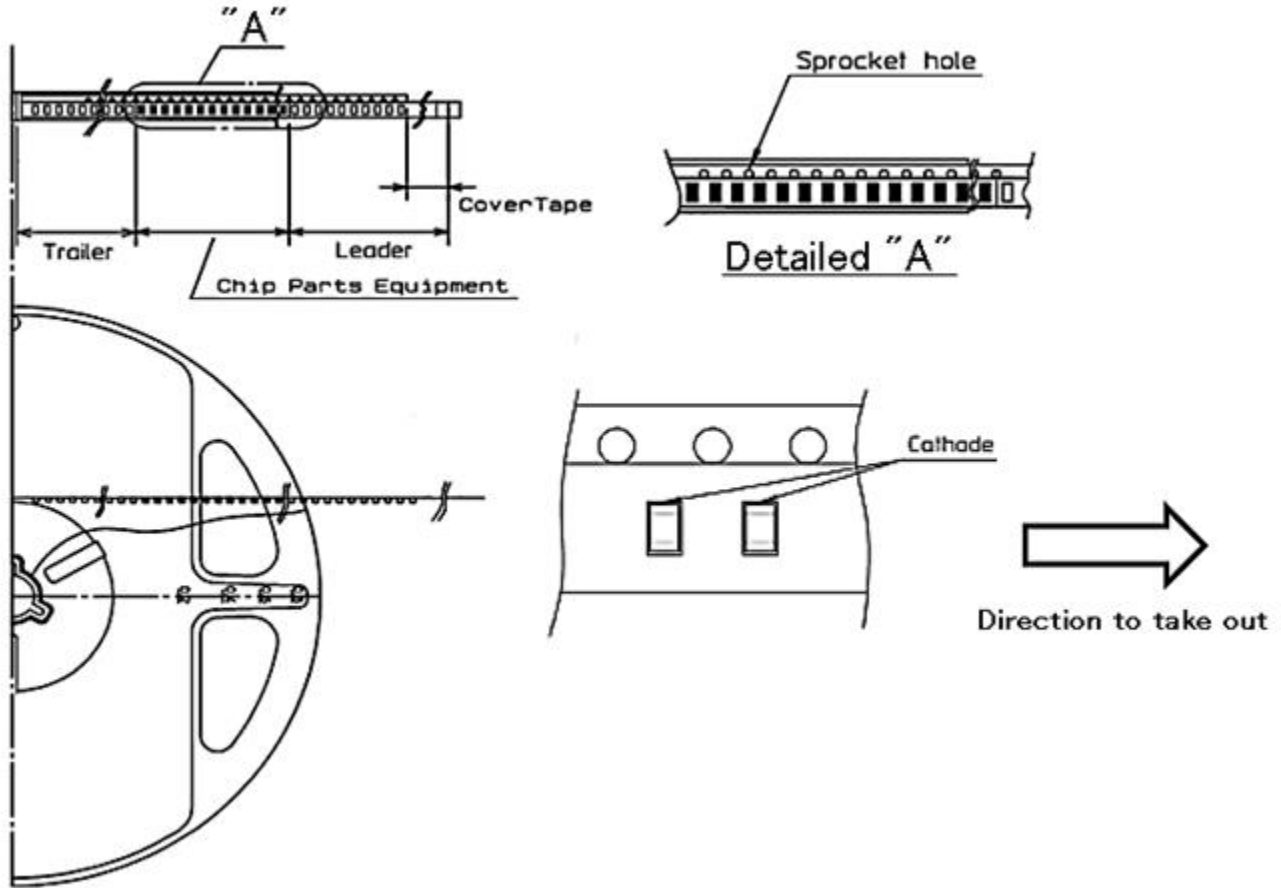



# Taping and Reel Specifications

## Taping Dimensions

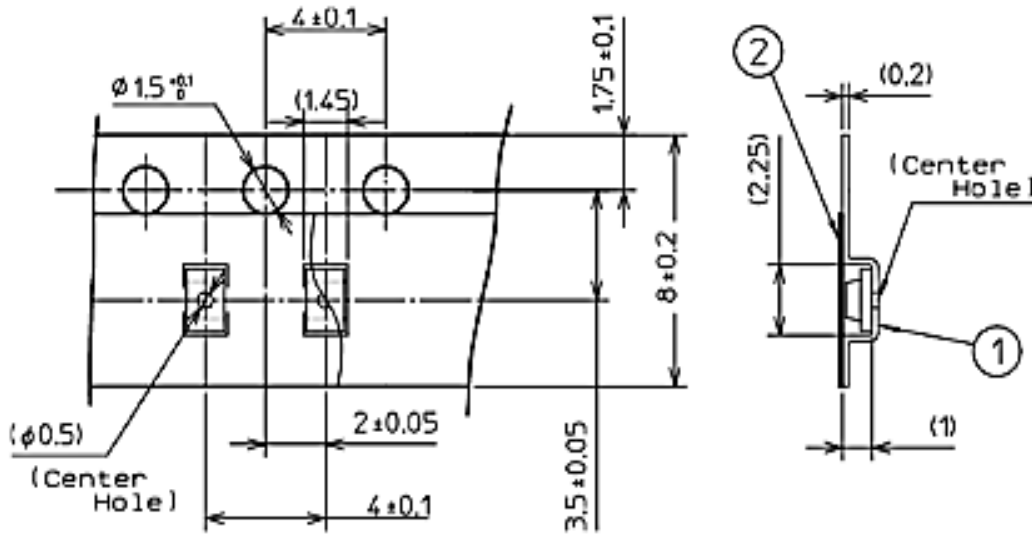

## Direction of Feed

## Reel Dimensions

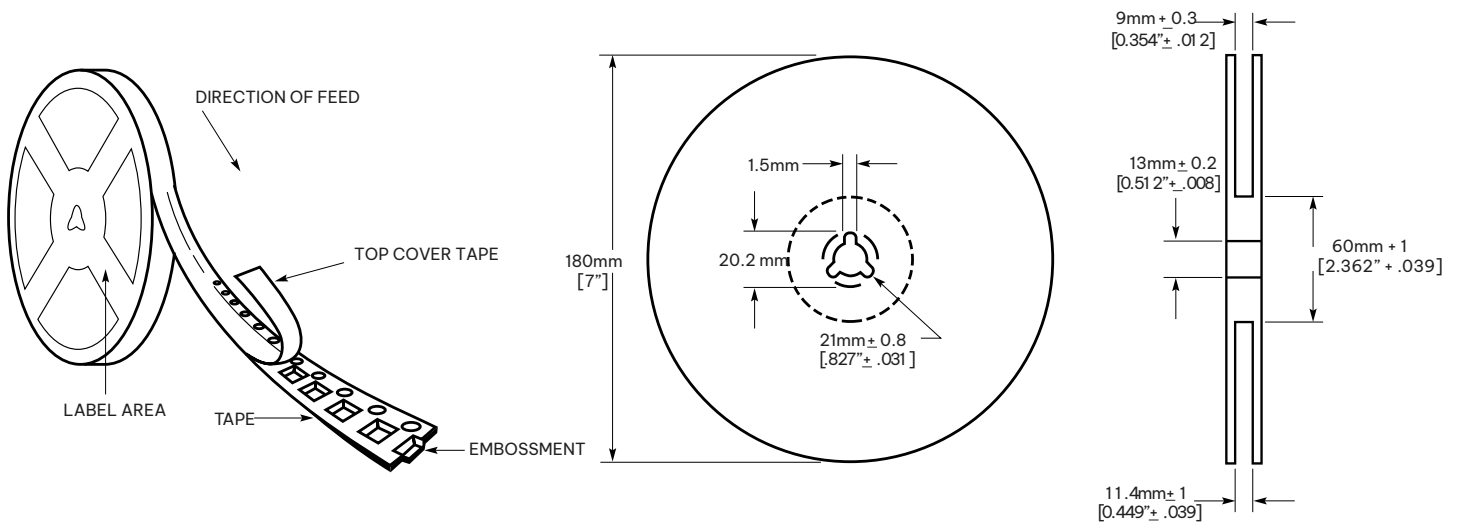

SYM.	PART NAME	REMARKS
①	Carrier-tape	Conductive Grade
②	Cover-tape	Anti-Static Grade
③	Carrier-reel	Anti-Static Grade



# Reliability Testing Result

Reliability Testing Result	Applicable Standard	Testing Conditions	Duration	Failure
Room Temp. Operating Life	EIAJ ED-4701/100(101)	Ta = 25°C, IF = Maximum Rated Current	1,000 h	0/25
Resistance to Soldering Heat	EIAJ ED-4701/300(301)	Pre-heating : 150~180°C 120s Max. Operation Heating : 230°C 40s Max. Peak Temperature : 260°C	Twice	0/25
Temperature Cycling	EIAJ ED-4701/100(105)	Minimum Rated Storage Temperature(30min) ~Normal Temperature(15min) ~Maximum Rated Storage Temperature(30min) ~Normal Temperature(15min)	5 cycles	0/25
Wet High Temp. Storage Life	EIAJ ED-4701/100(103)	Ta = 60±2°C, RH = 90±5%	1,000 h	0/25
High Temp. Storage Life	EIAJ ED-4701/200(201)	Ta = Maximum Rated Storage Temperature	1,000 h	0/25
Low Temp. Storage Life	EIAJ ED-4701/200(202)	Ta = Minimum Rated Storage Temperature	1,000 h	0/25
Vibration, Variable Frequency	EIAJ ED-4701/400(403)	98.1m/s <sup>2</sup> (10G), 100 ~ 2KHz sweep for 20min., XYZ each direction	2h	0/10
High Temperature Operating Life	EIAJ ED-4701/100(101)	Ta = 85°C, IF = Maximum Rated Current ※1	1,000 h	0/20
Low Temp. Operating Life	EIAJ ED-4701/100(101)	Ta = -40°C Maximum Rated Current	1,000 h	0/20
Wet High Temp. Operating Life	EIAJ ED-4701/100(102)	Ta = 60°C, RH = 90±5% Rated Current	1,000 h	0/20
Thermal Shock	EIAJ ED-4701/100(105)	Ta = Tstg max. ~ Tstg min. (each 15min)	1,000 cycles	0/20
Resistance to Reflow Soldering	EIAJ ED-4701/300(301)	Moisture Soak : 30°C 70% 168h Preheating : 150~180°C 120sec MAX. Soldering : 260°C 5sec	2 times	0/20
Electric Static Discharge(ESD) ※2	EIAJ ED-4701/300(304)	C=100pF R2=1.5KOHM ±2,000V	2h of each direction	0/10

※ Maximum Rated Current at Maximum Rated Operating Temperature



※ Reference test

## Compliances and approvals



## Looking for pricing, stock, or lifecycle information?

Click below to explore more details on WIN SOURCE:

-  [View 7012X5 on WIN SOURCE](#)
-  [Visual Communications Company - VCC Information](#)

## Optimize Your Supply Chain with WIN SOURCE Solutions

-  Global Sourcing Solution
-  Obsolete Management
-  Cost Control Management
-  Shortage Management
-  Alternative Solution
-  Excess Inventory Management