



**THE DATASHEET OF
ICS9DB306BLLFT**



GENERAL DESCRIPTION

The 9DB306 is a high performance 1-to-6 Differential-to-LVPECL Jitter Attenuator designed for use in PCI Express™ systems. In some PCI Express systems, such as those found in desktop PCs, the PCI Express clocks are generated from a low bandwidth, high phase noise PLL frequency synthesizer. In these systems, a zero delay buffer may be required to attenuate high frequency random and deterministic jitter components from the PLL synthesizer and from the system board. The 9DB306 has 2 PLL bandwidth modes. In low bandwidth mode, the PLL loop BW is about 500kHz and this setting will attenuate much of the jitter from the reference clock input while being high enough to pass a triangular input spread spectrum profile. There is also a high bandwidth mode which sets the PLL bandwidth at 1MHz which will pass more spread spectrum modulation.

For serdes which have x30 reference multipliers instead of x25 multipliers, 5 of the 6 PCI Express outputs (PCIEX1:5) can be set for 125MHz instead of 100MHz by configuring the appropriate frequency select pins (FS0:1). Output PCIEX0 will always run at the reference clock frequency (usually 100MHz) in desktop PC PCI Express Applications.

FEATURES

- Six differential LVPECL output pairs
- One differential clock input
- CLK and nCLK supports the following input types: LVPECL, LVDS, LVHSTL, SSTL, HCSL
- Maximum output frequency: 140MHz
- Input frequency range: 90MHz - 140MHz
- VCO range: 450MHz - 700MHz
- Output skew: 135ps (maximum)
- Cycle-to-Cycle jitter: 30ps (maximum)
- RMS phase jitter @ 100MHz, (1.5MHz - 22MHz): 3ps (typical)
- 3.3V operating supply
- 0°C to 70°C ambient operating temperature
- Available in lead-free (RoHS 6) package
- Industrial temperature information available upon request

BLOCK DIAGRAM

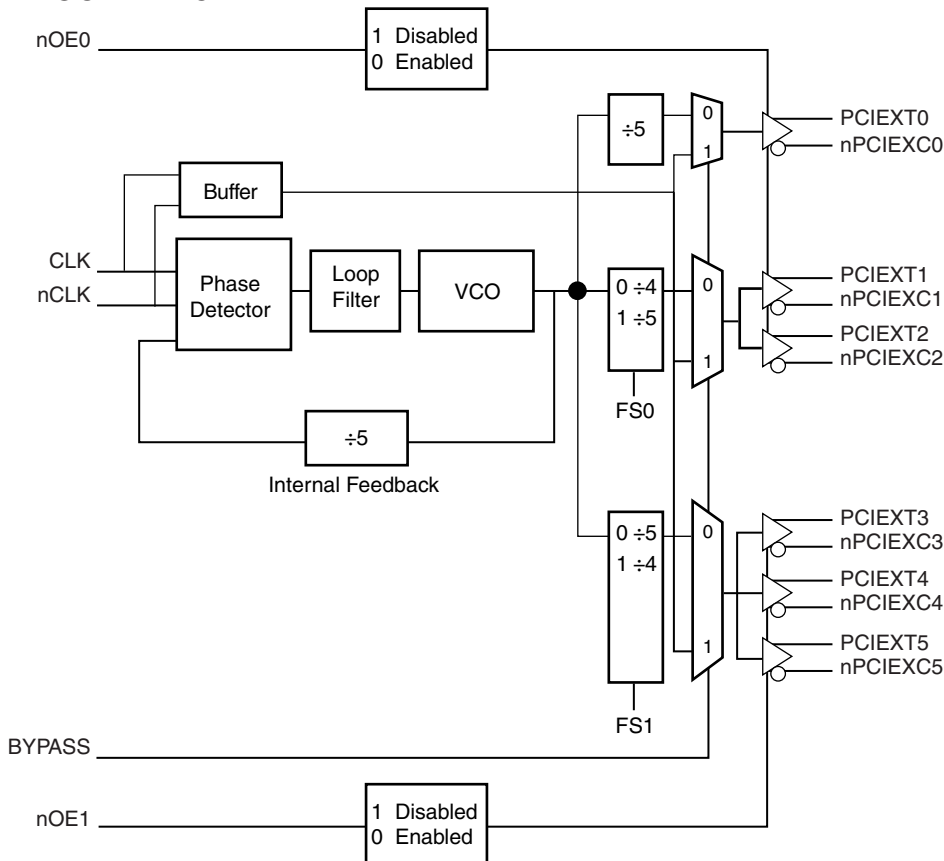

PIN ASSIGNMENT

VEE	1	28	VCC
PCIEXT1	2	27	PCIEXC0
PCIEXC1	3	26	PCIEXT0
PCIEXT2	4	25	FS0
PCIEXC2	5	24	nCLK
VCC	6	23	CLK
nOE0	7	22	PLL_BW
nOE1	8	21	VCCA
VCC	9	20	VEE
PCIEXC3	10	19	BYPASS
PCIEXT3	11	18	FS1
PCIEXC4	12	17	PCIEXT5
PCIEXT4	13	16	PCIEXC5
VEE	14	15	VCC

9DB306
28-Lead TSSOP, 173-MIL
 4.4mm x 9.7mm x 0.925mm
 body package
L Package
 Top View

9DB306
28-Lead, 209-MIL SSOP
 5.3mm x 10.2mm x 1.75mm
 body package
F Package
 Top View

TABLE 1. PIN DESCRIPTIONS

Number	Name	Type		Description
1, 14, 20	V _{EE}	Power		Negative supply pins.
2, 3	PCIEXT1, PCIEXC1	Output		Differential output pairs. LVPECL interface levels.
4, 5	PCIEXT2, PCIEXC2	Output		Differential output pairs. LVPECL interface levels.
6, 9, 15, 28	V _{CC}	Power		Core supply pins.
7, 8	nOE0, nOE1	Input	Pulldown	Output enable. When HIGH, forces true outputs (PCIEXTx) to go LOW and the inverted outputs (PCIEXCx) to go HIGH. When LOW, outputs are enabled. LVCMOS/LVTTL interface levels.
10, 11	PCIEXC3, PCIEXT3	Output		Differential output pairs. LVPECL interface levels.
12, 13	PCIEXC4, PCIEXT4	Output		Differential output pairs. LVPECL interface levels.
16, 17	PCIEXC5, PCIEXT5	Output		Differential output pairs. LVPECL interface levels.
18	FS1		Pulldown	Frequency select pin. LVCMOS/LVTTL interface levels.
19	BYPASS	Input	Pulldown	Bypass select pin. When HIGH, the PLL is in bypass mode, and the device can function as a 1:6 buffer. LVCMOS/LVTTL interface levels.
21	V _{CCA}	Power		Analog supply pin. Requires 24Ω series resistor.
22	PLL_BW	Input	Pullup	Selects PLL Bandwidth input. LVCMOS/LVTTL interface levels.
23	CLK	Input	Pulldown	Non-inverting differential clock input.
24	nCLK	Input	Pullup/ Pulldown	Inverting differential clock input. V _{cc} /2 default when left floating.
25	FS0	Input	Pullup	Frequency select pin. LVCMOS/LVTTL interface levels.
26, 27	PCIEXT0, PCIEXC0	Output		Differential output pairs. LVPECL interface levels.

NOTE: Pullup and Pulldown refer to internal input resistors. See Table 2, Pin Characteristics, for typical values.

TABLE 2. PIN CHARACTERISTICS

Symbol	Parameter	Test Conditions	Minimum	Typical	Maximum	Units
C _{IN}	Input Capacitance			4		pF
R _{PULLUP}	Input Pullup Resistor			51		kΩ
R _{PULLDOWN}	Input Pulldown Resistor			51		kΩ

TABLE 3A. RATIO OF OUTPUT FREQUENCY TO INPUT FREQUENCY FUNCTION TABLE, FS0

Inputs	Outputs			
	FS0	PCIEX0	PCIEX1	PCIEX2
0	1	5/4	5/4	
1	1	1	1	

TABLE 3B. RATIO OF OUTPUT FREQUENCY TO INPUT FREQUENCY FUNCTION TABLE, FS1

Inputs	Outputs			
	FS1	PCIEX3	PCIEX4	PCIEX5
0	1	1	1	
1	5/4	5/4	5/4	

TABLE 3C. OUTPUT ENABLE FUNCTION TABLE, nOE0

Inputs	Outputs
nOE0	PCIEX0:2
0	Enabled
1	Disabled

TABLE 3D. OUTPUT ENABLE FUNCTION TABLE, nOE1

Inputs	Outputs
nOE1	PCIEX3:5
0	Enabled
1	Disabled

TABLE 3E. PLL BANDWIDTH FUNCTION TABLE

Inputs	Bandwidth
PLL_BW	
0	500kHz
1	1MHz

TABLE 3F. PLL MODE FUNCTION TABLE

Inputs	PLL Mode
BYPASS	
1	Disabled
0	Enabled

ABSOLUTE MAXIMUM RATINGS

Supply Voltage, V_{CC}	4.6V
Inputs, V_I	-0.5V to $V_{CC} + 0.5V$
Outputs, I_O	
Continuous Current	50mA
Surge Current	100mA
Package Thermal Impedance, θ_{JA}	49.8°C/W (0 lfpm)
Storage Temperature, T_{STG}	-65°C to 150°C

NOTE: Stresses beyond those listed under Absolute Maximum Ratings may cause permanent damage to the device. These ratings are stress specifications only. Functional operation of product at these conditions or any conditions beyond those listed in the *DC Characteristics* or *AC Characteristics* is not implied. Exposure to absolute maximum rating conditions for extended periods may affect product reliability.

TABLE 4A. POWER SUPPLY DC CHARACTERISTICS, $V_{CC} = 3.3V \pm 10\%$, $T_A = 0^\circ C$ TO $70^\circ C$

Symbol	Parameter	Test Conditions	Minimum	Typical	Maximum	Units
V_{CC}	Core Supply Voltage		2.97	3.3	3.63	V
V_{CCA}	Analog Supply Voltage		$V_{CC} - 0.60$	3.3	V_{CC}	V
I_{CC}	Power Supply Current				135	mA
I_{CCA}	Analog Supply Current				25	mA

TABLE 4B. LVCMOS / LVTTTL DC CHARACTERISTICS, $V_{CC} = 3.3V \pm 10\%$, $T_A = 0^\circ C$ TO $70^\circ C$

Symbol	Parameter	Test Conditions	Minimum	Typical	Maximum	Units
V_{IH}	Input High Voltage		2		$V_{CC} + 0.3$	mV
V_{IL}	Input Low Voltage		-0.3		0.8	mV
I_{IH}	Input High Current	nOE0, nOE1, FS1, BYPASS	$V_{CC} = V_{IN} = 3.63V$		150	μA
		FS0, PLL_BW			5	μA
I_{IL}	Input Low Current	nOE0, nOE1, FS1, BYPASS	$V_{CC} = 3.63V, V_{IN} = 0V$	-5		μA
		FS0, PLL_BW		-150		μA

TABLE 4C. DIFFERENTIAL DC CHARACTERISTICS, $V_{CC} = 3.3V \pm 10\%$, $T_A = 0^\circ C$ TO $70^\circ C$

Symbol	Parameter	Test Conditions	Minimum	Typical	Maximum	Units
I_{IH}	Input High Current	CLK, nCLK	$V_{CC} = V_{IN} = 3.63V$		150	μA
I_{IL}	Input Low Current	CLK, nCLK	$V_{CC} = 3.63V, V_{IN} = 0V$		150	μA
V_{PP}	Peak-to-Peak Input Voltage; NOTE 1		0.15		1.3	V
V_{CMR}	Common Mode Input Voltage; NOTE 1, 2		$V_{EE} + 0.5$		$V_{CC} - 0.85$	V

NOTE 1: V_{IL} should not be less than -0.3V.

NOTE 2: Common mode voltage is defined as V_{IH} .

TABLE 4D. LVPECL DC CHARACTERISTICS, $V_{CC} = 3.3V \pm 10\%$, $T_A = 0^\circ C$ TO $70^\circ C$

Symbol	Parameter	Test Conditions	Minimum	Typical	Maximum	Units
V_{OH}	Output High Voltage; NOTE 1		$V_{CC} - 1.4$		$V_{CC} - 0.9$	V
V_{OL}	Output Low Voltage; NOTE 1		$V_{CC} - 2.0$		$V_{CC} - 1.7$	V
V_{SWING}	Peak-to-Peak Output Voltage Swing		0.6		1.0	V

NOTE 1: Outputs terminated with 50Ω to $V_{CC} - 2V$.

TABLE 5A. AC CHARACTERISTICS, $V_{CC} = 3.3V \pm 5\%$, $T_A = 0^\circ C$ TO $70^\circ C$

Symbol	Parameter	Test Conditions	Minimum	Typical	Maximum	Units
f_{MAX}	Output Frequency				140	MHz
$tsk(o)$	Output Skew; NOTE 1, 2			55	135	ps
$tjit(cc)$	Cycle-to-Cycle Jitter, NOTE 2				25	ps
$tjit(\emptyset)$	RMS Phase Jitter (Random); NOTE 3	Integration Range: 1.5MHz - 22MHz		3		ps
t_R / t_F	Output Rise/Fall Time	20% to 80%	200		700	ps
odc	Output Duty Cycle		48		52	%

NOTE: Electrical parameters are guaranteed over the specified ambient operating temperature range, which is established when the device is mounted in a test socket with maintained transverse airflow greater than 500 lfm. The device will meet specifications after thermal equilibrium has been reached under these conditions.

NOTE 1: Defined as skew between outputs at the same supply voltage and with equal load conditions.

Measured at the output differential cross points.

NOTE 2: This parameter is defined in accordance with JEDEC Standard 65.

NOTE 3: Please refer to the Phase Noise Plot following this section.

TABLE 5B. AC CHARACTERISTICS, $V_{CC} = 3.3V \pm 10\%$, $T_A = 0^\circ C$ TO $70^\circ C$

Symbol	Parameter	Test Conditions	Minimum	Typical	Maximum	Units
f_{MAX}	Output Frequency				140	MHz
$tsk(o)$	Output Skew; NOTE 1, 2			25	100	ps
$tjit(cc)$	Cycle-to-Cycle Jitter, NOTE 2				30	ps
$tjit(\emptyset)$	RMS Phase Jitter (Random); NOTE 3	Integration Range: 1.5MHz - 22MHz		3		ps
t_R / t_F	Output Rise/Fall Time	20% to 80%	200		700	ps
odc	Output Duty Cycle		47		53	%

NOTE: Electrical parameters are guaranteed over the specified ambient operating temperature range, which is established when the device is mounted in a test socket with maintained transverse airflow greater than 500 lfm. The device will meet specifications after thermal equilibrium has been reached under these conditions.

NOTE 1: Defined as skew between outputs at the same supply voltage and with equal load conditions.

Measured at the output differential cross points.

NOTE 2: This parameter is defined in accordance with JEDEC Standard 65.

NOTE 3: Please refer to the Phase Noise Plot following this section.

TYPICAL PHASE NOISE AT 100MHz

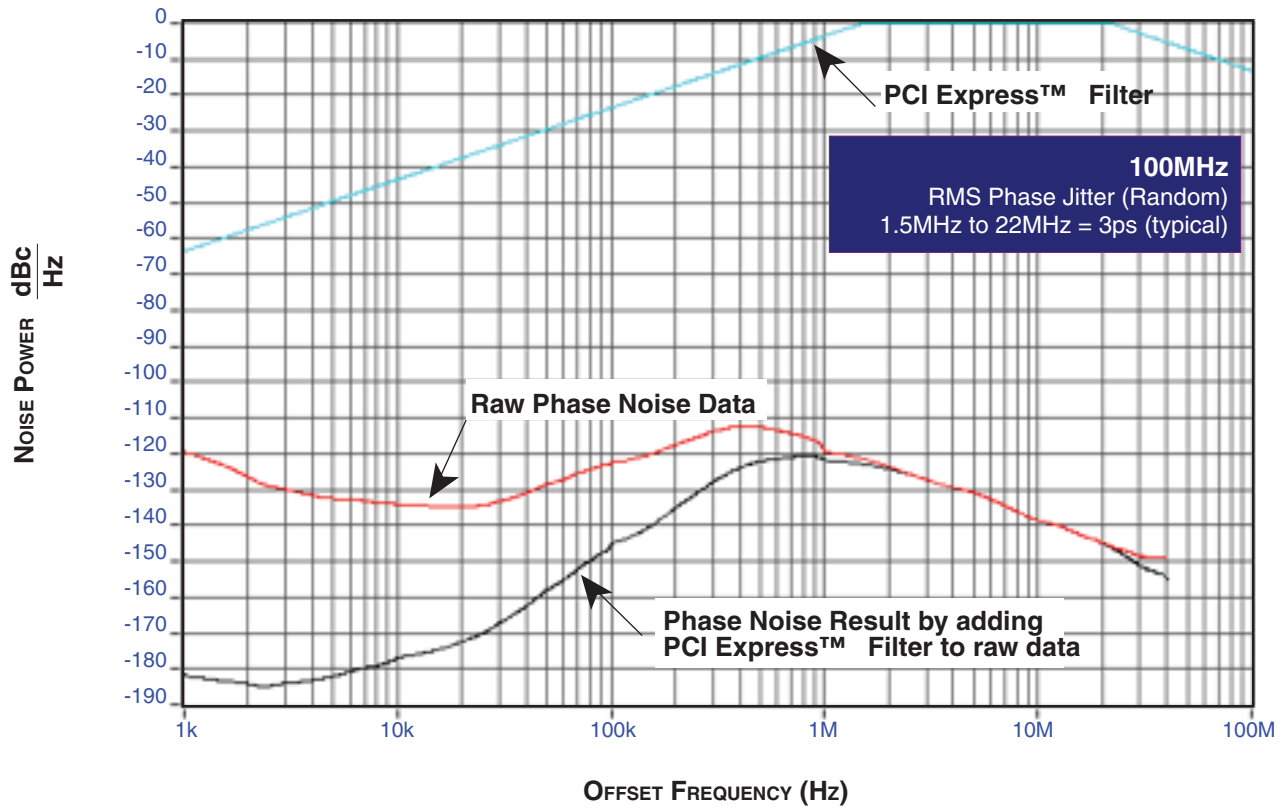

The illustrated phase noise plot was taken using a low phase noise signal generator, the noise floor of the signal generator is less than that of the device under test.

Using this configuration allows one to see the true spectral purity or phase noise performance of the PLL in the device under test. Due

to the tracking ability of a PLL, it will track the input signal up to its loop bandwidth. Therefore, if the input phase noise is greater than that of the PLL, it will increase the output phase noise performance of the device. It is recommended that the phase noise performance of the input is verified in order to achieve the above phase noise performance.

PARAMETER MEASUREMENT INFORMATION

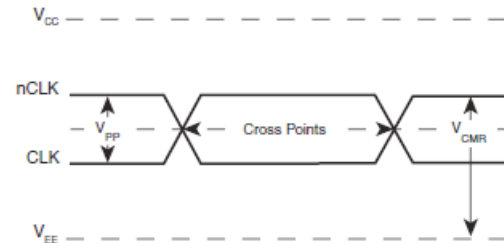
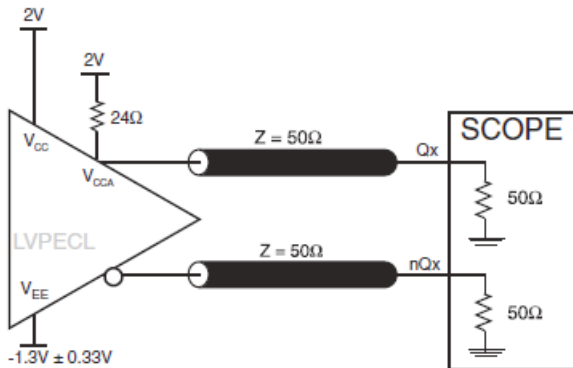
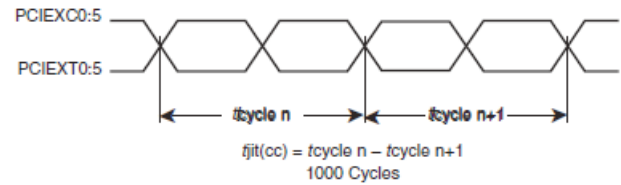
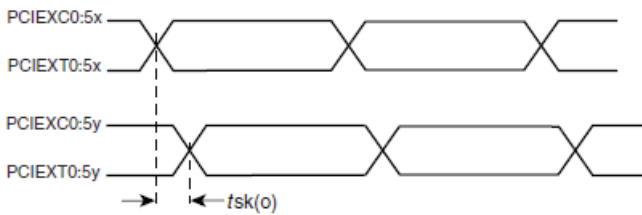
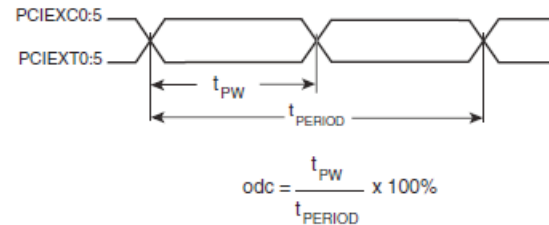
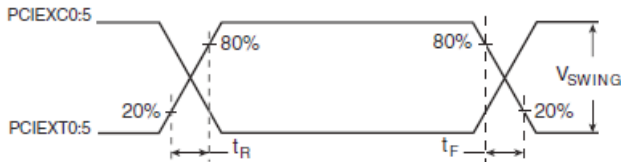
3.3V LVPECL OUTPUT LOAD AC TEST CIRCUIT
DIFFERENTIAL INPUT LEVEL

OUTPUT SKEW
CYCLE-TO-CYCLE JITTER

OUTPUT RISE/FALL TIME
OUTPUT DUTY CYCLE/PULSE WIDTH/PERIOD

APPLICATION INFORMATION

POWER SUPPLY FILTERING TECHNIQUES

As in any high speed analog circuitry, the power supply pins are vulnerable to random noise. To achieve optimum jitter performance, power supply isolation is required. The 9DB306 provides separate power supplies to isolate any high switching noise from the outputs to the internal PLL. V_{CC} and V_{CCA} should be individually connected to the power supply plane through vias, and $0.01\mu\text{F}$ bypass capacitors should be used for each pin. *Figure 1* illustrates this for a generic V_{CC} pin and also shows that V_{CCA} requires that an additional 24Ω resistor along with a $10\mu\text{F}$ bypass capacitor be connected to the V_{CCA} pin.

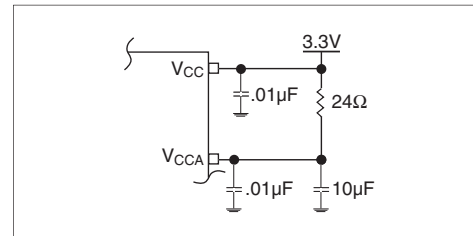

FIGURE 1. POWER SUPPLY FILTERING

WIRING THE DIFFERENTIAL INPUT TO ACCEPT SINGLE ENDED LEVELS

Figure 2 shows how the differential input can be wired to accept single ended levels. The reference voltage $V_{REF} = V_{DD}/2$ is generated by the bias resistors $R1$, $R2$ and $C1$. This bias circuit should be located as close as possible to the input pin. The ratio

of $R1$ and $R2$ might need to be adjusted to position the V_{REF} in the center of the input voltage swing. For example, if the input clock swing is only 2.5V and $V_{CC} = 3.3\text{V}$, V_{REF} should be 1.25V and $R2/R1 = 0.609$.

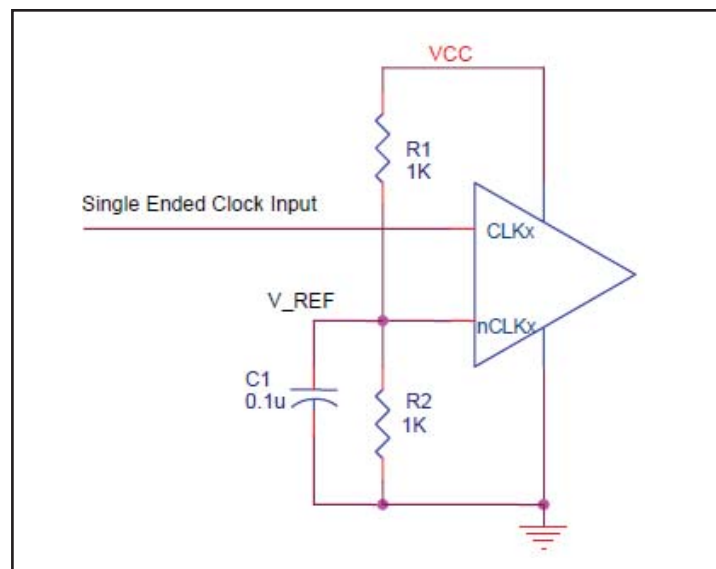

FIGURE 2. SINGLE ENDED SIGNAL DRIVING DIFFERENTIAL INPUT

DIFFERENTIAL CLOCK INPUT INTERFACE

The CLK /nCLK accepts LVDS, LVPECL, LVHSTL, SSTL, HCSL and other differential signals. Both V_{SWING} and V_{OH} must meet the V_{PP} and V_{CMR} input requirements. Figures 3A to 3E show interface examples for the CLK/nCLK input driven by the most common driver types. The input interfaces suggested here are examples

only. Please consult with the vendor of the driver component to confirm the driver termination requirements. For example in *Figure 3A*, the input termination applies for IDT LVHSTL drivers. If you are using an LVHSTL driver from another vendor, use their termination recommendation.

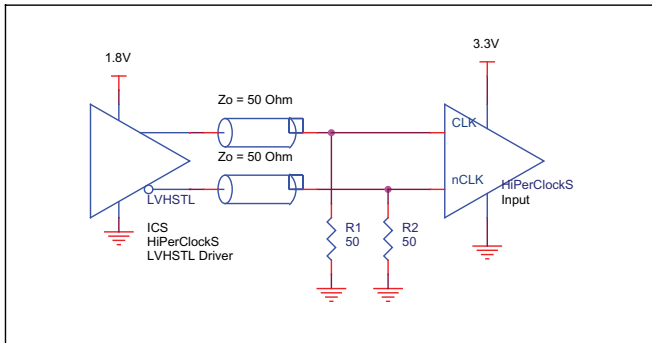

FIGURE 3A. CLK/nCLK INPUT DRIVEN BY AN IDT LVHSTL DRIVER

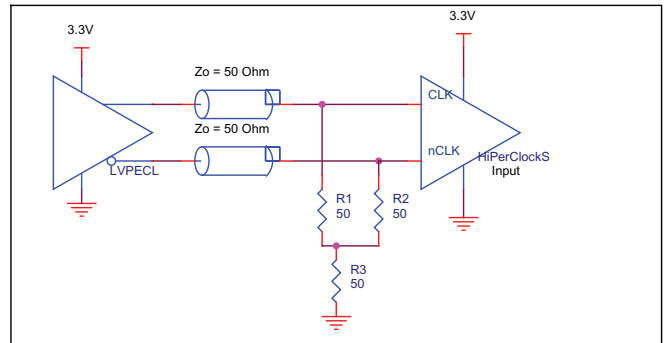

FIGURE 3B. CLK/nCLK INPUT DRIVEN BY A 3.3V LVPECL DRIVER

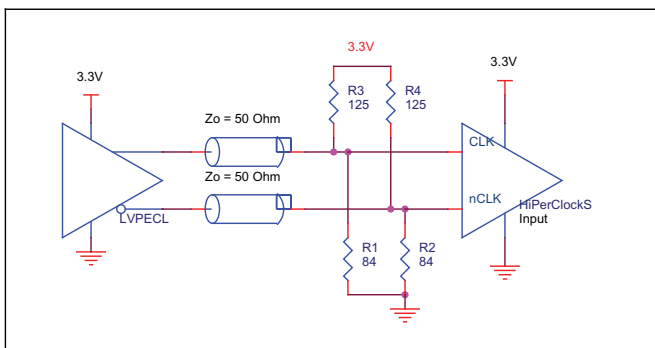

FIGURE 3C. CLK/nCLK INPUT DRIVEN BY A 3.3V LVPECL DRIVER

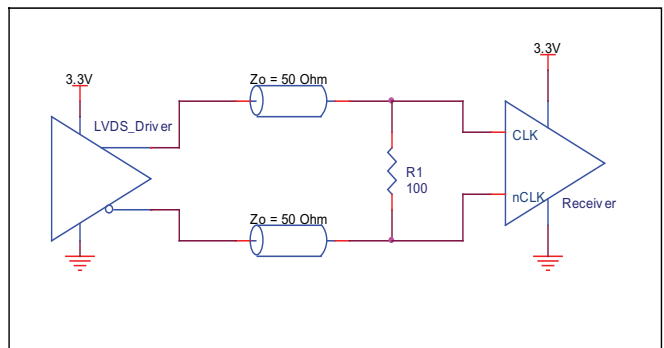

FIGURE 3D. CLK/nCLK INPUT DRIVEN BY A 3.3V LVDS DRIVER

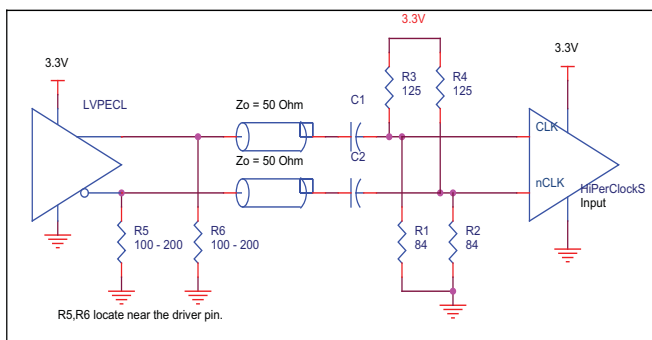

FIGURE 3E. CLK/nCLK INPUT DRIVEN BY A 3.3V LVPECL DRIVER WITH AC COUPLE

TERMINATION FOR LVPECL OUTPUTS

The clock layout topology shown below is a typical termination for LVPECL outputs. The two different layouts mentioned are recommended only as guidelines.

The differential outputs are low impedance follower outputs that generate ECL/LVPECL compatible outputs. Therefore, terminating resistors (DC current path to ground) or current sources must be used for functionality. These outputs are designed to drive 50Ω transmission lines. Matched impedance techniques should be used

to maximize operating frequency and minimize signal distortion. *Figures 4A and 4B* show two different layouts which are recommended only as guidelines. Other suitable clock layouts may exist and it would be recommended that the board designers simulate to guarantee compatibility across all printed circuit and clock component process variations.

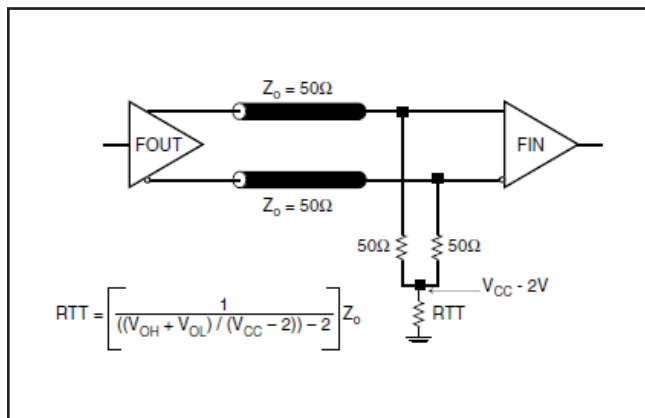

FIGURE 4A. LVPECL OUTPUT TERMINATION

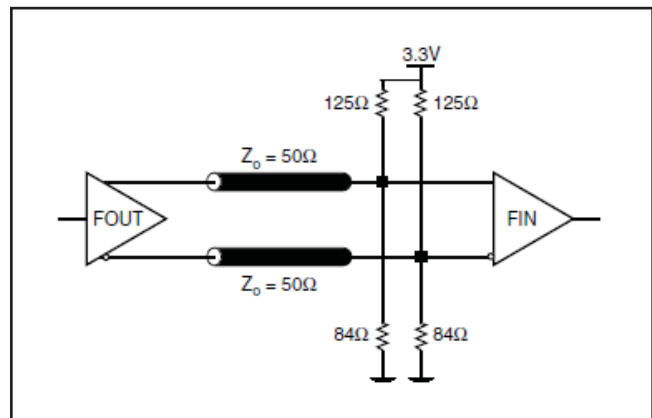

FIGURE 4B. LVPECL OUTPUT TERMINATION

RECOMMENDATIONS FOR UNUSED INPUT AND OUTPUT PINS

INPUTS:

LVC MOS CONTROL PINS

All control pins have internal pullups or pulldowns; additional resistance is not required but can be added for additional protection. A 1kΩ resistor can be used.

OUTPUTS:

LVPECL OUTPUTS

All unused LVPECL outputs can be left floating. We recommend that there is no trace attached. Both sides of the differential output pair should either be left floating or terminated.

POWER CONSIDERATIONS

This section provides information on power dissipation and junction temperature for the 9DB306. Equations and example calculations are also provided.

1. Power Dissipation.

The total power dissipation for the 9DB306 is the sum of the core power plus the power dissipated in the load(s). The following is the power dissipation for $V_{CC} = 3.3V + 10\% = 3.63V$, which gives worst case results.

NOTE: Please refer to Section 3 for details on calculating power dissipated in the load.

- Power (core)_{MAX} = $V_{CC,MAX} * I_{EE,MAX} = 3.63V * 135mA = 490.1mW$
- Power (outputs)_{MAX} = **30mW/Loaded Output pair**
If all outputs are loaded, the total power is $6 * 30mW = 180mW$

$$\text{Total Power}_{MAX} (3.63V, \text{ with all outputs switching}) = 490.1mW + 180mW = \mathbf{670.1mW}$$

2. Junction Temperature.

Junction temperature at the junction of the bond wire and bond pad directly affects the reliability of the device. The maximum recommended junction temperature is 125°C. Limiting the internal transistor junction temperature, T_J, to 125°C ensures that the bond wire and bond pad temperature remains below 125°C.

The equation for T_J is as follows: $T_J = \theta_{JA} * Pd_{total} + T_A$

T_J = Junction Temperature

θ_{JA} = Junction-to-Ambient Thermal Resistance

Pd_{total} = Total Device Power Dissipation (example calculation is in section 1 above)

T_A = Ambient Temperature

In order to calculate junction temperature, the appropriate junction-to-ambient thermal resistance θ_{JA} must be used. Assuming a moderate air flow of 200 linear feet per minute and a multi-layer board, the appropriate value is 43.9°C/W per Table 6 below.

Therefore, T_J for an ambient temperature of 70°C with all outputs switching is:

$$70^\circ\text{C} + 0.670W * 43.9^\circ\text{C/W} = 99.4^\circ\text{C}. \text{ This is well below the limit of } 125^\circ\text{C}.$$

This calculation is only an example. T_J will obviously vary depending on the number of loaded outputs, supply voltage, air flow, and the type of board (single layer or multi-layer).

TABLE 6. THERMAL RESISTANCE θ_{JA} FOR 28-PIN TSSOP, FORCED CONVECTION

	θ_{JA} by Velocity (Linear Feet per Minute)		
	0	200	500
Single-Layer PCB, JEDEC Standard Test Boards	82.9°C/W	68.7°C/W	60.5°C/W
Multi-Layer PCB, JEDEC Standard Test Boards	49.8°C/W	43.9°C/W	41.2°C/W

NOTE: Most modern PCB designs use multi-layered boards. The data in the second row pertains to most designs.

3. Calculations and Equations.

The purpose of this section is to derive the power dissipated into the load.

LVPECL output driver circuit and termination are shown in *Figure 6*.

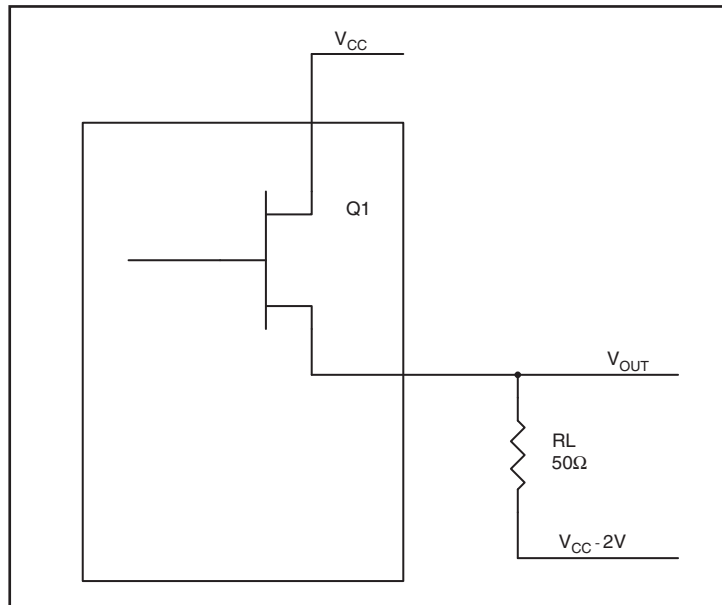

FIGURE 6. LVPECL DRIVER CIRCUIT AND TERMINATION

To calculate worst case power dissipation into the load, use the following equations which assume a 50Ω load, and a termination voltage of $V_{CC} - 2V$.

- For logic high, $V_{OUT} = V_{OH_MAX} = V_{CC_MAX} - 0.9V$

$$(V_{CC_MAX} - V_{OH_MAX}) = 0.9V$$

- For logic low, $V_{OUT} = V_{OL_MAX} = V_{CC_MAX} - 1.7V$

$$(V_{CC_MAX} - V_{OL_MAX}) = 1.7V$$

Pd_H is power dissipation when the output drives high.

Pd_L is the power dissipation when the output drives low.

$$Pd_H = [(V_{OH_MAX} - (V_{CC_MAX} - 2V))/R_L] * (V_{CC_MAX} - V_{OH_MAX}) = [(2V - (V_{CC_MAX} - V_{OH_MAX}))/R_L] * (V_{CC_MAX} - V_{OH_MAX}) = [(2V - 0.9V)/50\Omega] * 0.9V = 19.8mW$$

$$Pd_L = [(V_{OL_MAX} - (V_{CC_MAX} - 2V))/R_L] * (V_{CC_MAX} - V_{OL_MAX}) = [(2V - (V_{CC_MAX} - V_{OL_MAX}))/R_L] * (V_{CC_MAX} - V_{OL_MAX}) = [(2V - 1.7V)/50\Omega] * 1.7V = 10.2mW$$

$$\text{Total Power Dissipation per output pair} = Pd_H + Pd_L = 30mW$$

RELIABILITY INFORMATION

TABLE 7A. θ_{JA} vs. AIR FLOW TABLE FOR 28 LEAD TSSOP PACKAGE

θ_{JA} by Velocity (Linear Feet per Minute)			
	0	200	500
Single-Layer PCB, JEDEC Standard Test Boards	82.9°C/W	68.7°C/W	60.5°C/W
Multi-Layer PCB, JEDEC Standard Test Boards	49.8°C/W	43.9°C/W	41.2°C/W

NOTE: Most modern PCB designs use multi-layered boards. The data in the second row pertains to most designs.

TABLE 7B. θ_{JA} vs. AIR FLOW TABLE FOR 28 LEAD SSOP PACKAGE

θ_{JA} by Velocity (Linear Feet per Minute)			
	0	200	500
Multi-Layer PCB, JEDEC Standard Test Boards	49°C/W	36°C/W	30°C/W

TRANSISTOR COUNT

The transistor count for 9DB306 is: 2190

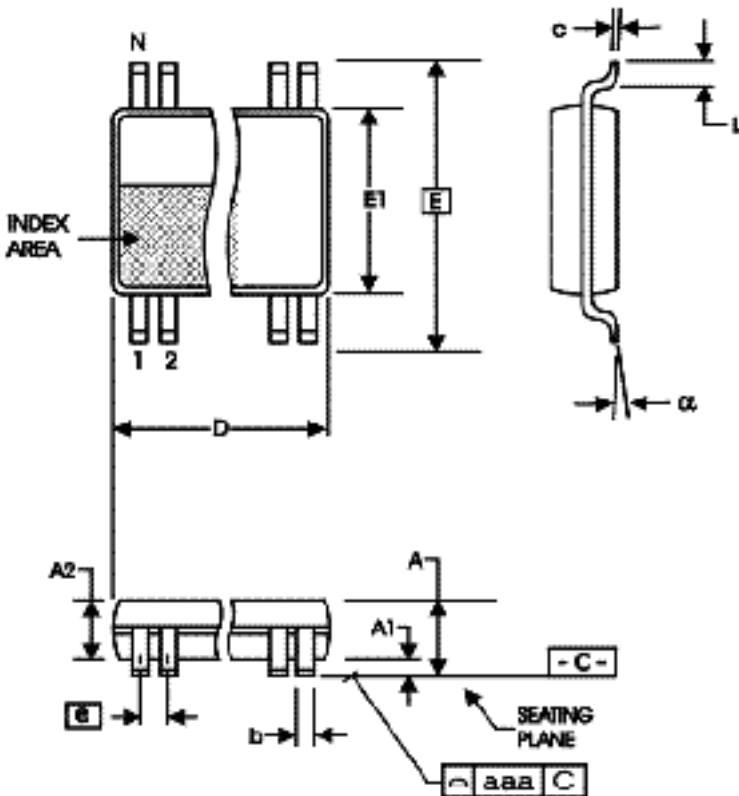
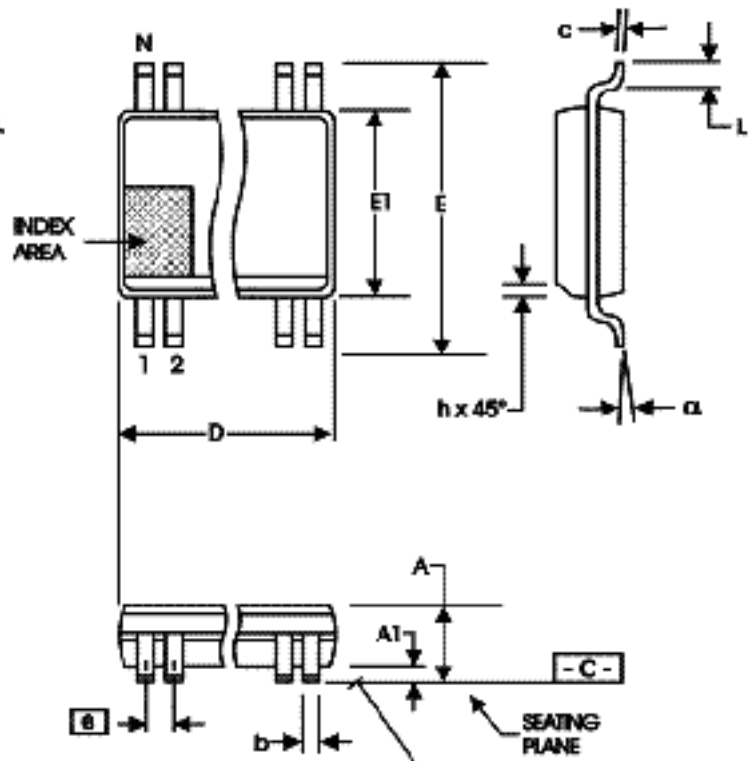
PACKAGE OUTLINE - G SUFFIX FOR 28 LEAD TSSOP

PACKAGE OUTLINE - F SUFFIX FOR 28 LEAD SSOP

TABLE 8A. PACKAGE DIMENSIONS

SYMBOL	Millimeters	
	Minimum	Maximum
N	28	
A	--	1.20
A1	0.05	0.15
A2	0.80	1.05
b	0.19	0.30
c	0.09	0.20
D	9.60	9.80
E	6.40 BASIC	
E1	4.30	4.50
e	0.65 BASIC	
L	0.45	0.75
α	0°	8°
aaa	--	0.10

Reference Document: JEDEC Publication 95, MO-153

TABLE 8B. PACKAGE DIMENSIONS

SYMBOL	Millimeters	
	Minimum	Maximum
N	28	
A	--	2.0
A1	0.05	--
A2	1.65	1.85
b	0.22	0.38
c	0.09	0.25
D	9.90	10.50
E	7.40	8.20
E1	5.0	5.60
e	0.65 BASIC	
L	0.55	0.95
α	0°	8°

Reference Document: JEDEC Publication 95, MO-150

TABLE 9. ORDERING INFORMATION

Part/Order Number	Marking	Package	Shipping Packaging	Temperature
9DB306BLLF	ICS9DB306BLLF	28 Lead "Lead-Free" TSSOP	Tube	0°C to 70°C
9DB306BLLFT	ICS9DB306BLLF	28 Lead "Lead-Free" TSSOP	tape & reel	0°C to 70°C
9DB306BFLF	ICS9DB306BFLF	28 Lead "Lead-Free" SSOP	Tube	0°C to 70°C
9DB306BFLFT	ICS9DB306BFLF	28 Lead "Lead-Free" SSOP	tape & reel	0°C to 70°C

REVISION HISTORY SHEET				
Rev	Table	Page	Description of Change	Date
A	T3F	2	Added PLL Mode Function Table.	4/7/05
B	T4A	3	Power Supply Table - minimum V_{CCA} changed from 3.135V to $V_{CC} - 0.60V$, and maximum set to V_{CC} .	6/16/06
		6	Corrected <i>3.3V Output Load AC Test Circuit diagram</i> to correspond with Power Supply table.	
	8	Added <i>Recommendations for Unused Input and Output Pins</i> .		
	T9	15	Ordering Information Table - added lead-free SSOP part number.	
B		1	Features Section - added Input Frequency Range and VCO Range bullets.	7/14/06
C	T5	4	Changed power supply from 3.3V±5% to 3.3V±10% throughout the datasheet. AC Characteristics Table - changed Output Skew from 55ps typ./135ps max. to 25ps typ./100ps max. Changed Cycle-toCycle Jitter from 25ps max. to 30ps max. Changed Output Duty Cycle from 48% min./52% max. to 47% min./53% max.	9/22/06
		11	Power Considerations - correct Power Dissipation to coincide with the power supply change.	
C	T4C T5A - T5B	3	Differential DC Characteristics Table - updated notes.	8/13/09
		4	AC Characteristics Tables - added thermal note.	
	7	Power Supply Filtering Techniques - deleted last line " The 10ohm resistor can also be replaced by a ferrite bead."		
	8	Updated Differential Clock Input Interface section.		
	9	Updated Figures 4A and 4B.		
	T9	15	Ordering Information Table - deleted ICS prefix in Part/Order Number column. Added 28 Lead SSOP Lead-free marking.	
C		14	Package Information - Table 8A and 8B corrected D and N dimensions.	3/14/12
C	T9	15	Ordering Information - removed leaded devices. Updated data sheet format.	7/24/15
C	T9	15	Ordering Information - removed quantities in tape and reel. Deleted LF note below table. Updated header and footer.	2/18/16



Corporate Headquarters
6024 Silver Creek Valley Road
San Jose, CA 95138 USA
www.IDT.com

Sales
1-800-345-7015 or 408-284-8200
Fax: 408-284-2775
www.IDT.com/go/sales

Tech Support
www.idt.com/go/support

DISCLAIMER Integrated Device Technology, Inc. (IDT) reserves the right to modify the products and/or specifications described herein at any time, without notice, at IDT's sole discretion. Performance specifications and operating parameters of the described products are determined in an independent state and are not guaranteed to perform the same way when installed in customer products. The information contained herein is provided without representation or warranty of any kind, whether express or implied, including, but not limited to, the suitability of IDT's products for any particular purpose, an implied warranty of merchantability, or non-infringement of the intellectual property rights of others. This document is presented only as a guide and does not convey any license under intellectual property rights of IDT or any third parties.

IDT's products are not intended for use in applications involving extreme environmental conditions or in life support systems or similar devices where the failure or malfunction of an IDT product can be reasonably expected to significantly affect the health or safety of users. Anyone using an IDT product in such a manner does so at their own risk, absent an express, written agreement by IDT.

Integrated Device Technology, IDT and the IDT logo are trademarks or registered trademarks of IDT and its subsidiaries in the United States and other countries. Other trademarks used herein are the property of IDT or their respective third party owners.

For datasheet type definitions and a glossary of common terms, visit www.idt.com/go/glossary.

Copyright ©2016 Integrated Device Technology, Inc. All rights reserved.

Looking for pricing, stock, or lifecycle information?

Click below to explore more details on WIN SOURCE:

- ⊖ [View ICS9DB306BLLFT on WIN SOURCE](#)
- ⊖ [IDT, Integrated Device Technology Inc Information](#)

Optimize Your Supply Chain with WIN SOURCE Solutions

- ✓ Global Sourcing Solution
- ✓ Obsolete Management
- ✓ Cost Control Management
- ✓ Shortage Management
- ✓ Alternative Solution
- ✓ Excess Inventory Management