



**THE DATASHEET OF
ICS9DB206CFLFT**



PRODUCT DISCONTINUATION NOTICE - LAST TIME BUY EXPIRES SEPTEMBER 7, 2016

GENERAL DESCRIPTION

The 9DB206 is a high performance 1-to-6 Differential-to-HCSL Jitter Attenuator designed for use in PCI Express™ systems. In some PCI Express systems, such as those found in desktop PCs, the PCI Express clocks are generated from a low bandwidth, high phase noise PLL frequency synthesizer. In these systems, a jitter-attenuating device may be necessary in order to reduce high frequency random and deterministic jitter components from the PLL synthesizer and from the system board. The 9DB206 has two PLL bandwidth modes. In low bandwidth mode, the PLL loop bandwidth is 500kHz. This setting offers the best jitter attenuation and is still high enough to pass a triangular input spread spectrum profile. In high bandwidth mode, the PLL bandwidth is at 1MHz and allows the PLL to pass more spread spectrum modulation.

For serdes which have x10 reference multipliers instead of x12.5 multipliers, 5 of the 6 PCI Express outputs (PCIEX1:5) can be set for 125MHz instead of 100MHz by configuring the appropriate frequency select pins (FS0:1). Output PCIEX0 will always run at the reference clock frequency (usually 100MHz) in desktop PC PCI Express Applications.

Features

- Six 0.7V current mode differential HCSL output pairs
- One differential clock input
- CLK and nCLK supports the following input types: LVPECL, LVDS, LVHSTL, SSTL, HCSL
- Maximum output frequency: 140MHz
- Input frequency range: 90MHz - 140MHz
- VCO range: 450MHz - 700MHz
- Output skew: 110ps (maximum)
- Cycle-to-Cycle jitter: 110ps (maximum)
- RMS phase jitter @ 100MHz, (1.5MHz - 22MHz): 2.42ps (typical)
- 3.3V operating supply
- 0°C to 70°C ambient operating temperature
- Available in lead-free RoHS compliant package
- Industrial temperature information available upon request

BLOCK DIAGRAM

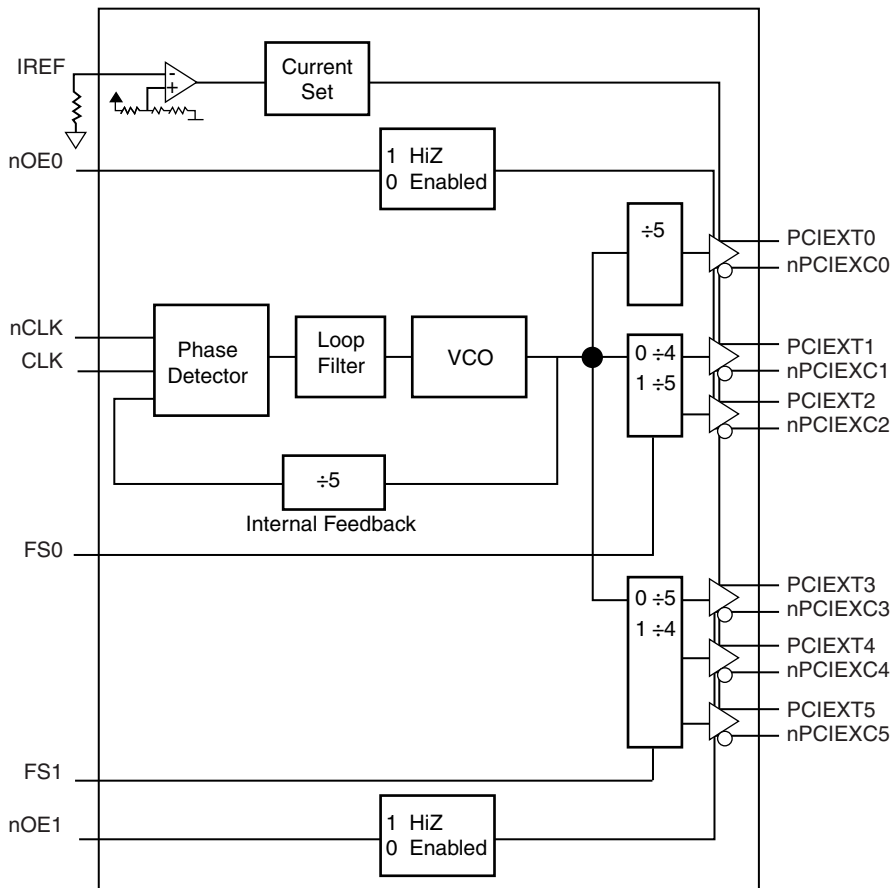

PIN ASSIGNMENT

PLL_BW	1	28	VDDA
CLK	2	27	GND
nCLK	3	26	IREF
FS0	4	25	FS1
PCIEXT0	5	24	PCIEXT5
PCIEXC0	6	23	PCIEXC5
VDD	7	22	VDD
GND	8	21	GND
PCIEXT1	9	20	PCIEXT4
PCIEXC1	10	19	PCIEXC4
PCIEXT2	11	18	PCIEXT3
PCIEXC2	12	17	PCIEXC3
VDD	13	16	VDD
nOE0	14	15	nOE1

9DB206

28-Lead TSSOP, 173-MIL

4.4mm x 9.7mm x 0.92mm body package

L Package

Top View

9DB206

28-Lead, 209-MIL SSOP

5.3mm x 10.2mm x 1.75mm body package

F Package

Top View

TABLE 1. PIN DESCRIPTIONS

Number	Name	Type		Description
1	PLL_BW	Input	Pullup	Selects PLL Bandwidth input. LVCMOS/LVTTL interface levels.
2	CLK	Input	Pulldown	Non-inverting differential clock input.
3	nCLK	Input	Pullup/ Pulldown	Inverting differential clock input. $V_{DD}/2$ default when left floating.
4	FS0	Input	Pullup	Frequency select pin. LVCMOS/LVTTL interface levels.
5, 6	PCIEXT0, PCIEXC0	Output		Differential output pairs. HCSL interface levels.
7, 13, 16, 22	V_{DD}	Power		Core supply pins.
8, 21	GND	Power		Power supply ground.
9, 10	PCIEXT1, PCIEXC1	Output		Differential output pairs. HCSL interface levels.
11, 12	PCIEXT2, PCIEXC2	Output		Differential output pairs. HCSL interface levels.
14, 15	nOE0, nOE1	Input	Pulldown	Output enable. When HIGH, forces outputs to HiZ state. When LOW, enables outputs. LVCMOS/LVTTL interface levels.
17, 18	PCIEXC3, PCIEXT3	Output		Differential output pairs. HCSL interface levels.
19, 20	PCIEXC4, PCIEXT4	Output		Differential output pairs. HCSL interface levels.
23, 24	PCIEXC5, PCIEXT5	Output		Differential output pairs. HCSL interface levels.
25	FS1	Input	Pulldown	Frequency select pin. LVCMOS/LVTTL interface levels.
26	IREF	Input		A fixed precision resistor (475 Ω) from this pin to ground provides a reference current used for differential current-mode PCIEX clock outputs.
27	GND	Power		Power supply ground.
28	V_{DDA}	Power		Analog supply pin. Requires 24 Ω series resistor.

NOTE: Pullup and Pulldown refer to internal input resistors. See Table 2, Pin Characteristics, for typical values.

TABLE 2. PIN CHARACTERISTICS

Symbol	Parameter	Test Conditions	Minimum	Typical	Maximum	Units
C_{IN}	Input Capacitance			4		pF
R_{PULLUP}	Input Pullup Resistor			51		k Ω
$R_{PULLDOWN}$	Input Pulldown Resistor			51		k Ω

TABLE 3A. RATIO OF OUTPUT FREQUENCY TO INPUT FREQUENCY FUNCTION TABLE, FS0

Inputs	Outputs			
	FS0	PCIEX0	PCIEX1	PCIEX2
0	1	5/4	5/4	
1	1	1	1	

TABLE 3B. RATIO OF OUTPUT FREQUENCY TO INPUT FREQUENCY FUNCTION TABLE, FS1

Inputs	Outputs			
	FS1	PCIEX3	PCIEX4	PCIEX5
0	1	1	1	
1	5/4	5/4	5/4	

TABLE 3C. OUTPUT ENABLE FUNCTION TABLE, nOE0

Inputs	Outputs
nOE0	PCIEX0:2
0	Enabled
1	HiZ

TABLE 3D. OUTPUT ENABLE FUNCTION TABLE, nOE1

Inputs	Outputs
nOE1	PCIEX3:5
0	Enabled
1	HiZ

TABLE 3E. PLL BANDWIDTH TABLE

Inputs	Bandwidth
PLL_BW	
0	500kHz
1	1MHz

ABSOLUTE MAXIMUM RATINGS

Supply Voltage, V_{DD}	4.6V
Inputs, V_I	-0.5V to $V_{DD} + 0.5V$
Outputs, V_O	-0.5V to $V_{DD} + 0.5V$
Package Thermal Impedance, θ_{JA}	
28 Lead TSSOP	49.8°C/W (0 lfpm)
28 Lead SSOP	49°C/W (0 lfpm)
Storage Temperature, T_{STG}	-65°C to 150°C

NOTE: Stresses beyond those listed under Absolute Maximum Ratings may cause permanent damage to the device. These ratings are stress specifications only. Functional operation of product at these conditions or any conditions beyond those listed in the *DC Characteristics* or *AC Characteristics* is not implied. Exposure to absolute maximum rating conditions for extended periods may affect product reliability.

TABLE 4A. POWER SUPPLY DC CHARACTERISTICS, $V_{DD} = V_{DDA} = 3.3V \pm 5\%$, $T_A = 0^\circ C$ TO $70^\circ C$, $R_{REF} = 475\Omega$

Symbol	Parameter	Test Conditions	Minimum	Typical	Maximum	Units
V_{DD}	Core Supply Voltage		3.135	3.3	3.465	V
V_{DDA}	Analog Supply Voltage		3.135	3.3	3.465	V
I_{DD}	Power Supply Current				112	mA
I_{DDA}	Analog Supply Current				22	mA

TABLE 4B. LVCMOS / LVTTTL DC CHARACTERISTICS, $V_{DD} = V_{DDA} = 3.3V \pm 5\%$, $T_A = 0^\circ C$ TO $70^\circ C$

Symbol	Parameter	Test Conditions	Minimum	Typical	Maximum	Units
V_{IH}	Input High Voltage		2		$V_{DD} + 0.3$	mV
V_{IL}	Input Low Voltage		-0.3		0.8	mV
I_{IH}	Input High Current	FS1, nOE0, nOE1	$V_{DD} = V_{IN} = 3.465V$		150	μA
		FS0, PLL_BW			5	μA
I_{IL}	Input Low Current	FS1, nOE0, nOE1	$V_{DD} = 3.465V, V_{IN} = 0V$	-5		μA
		FS0, PLL_BW		-150		μA

TABLE 4C. DIFFERENTIAL DC CHARACTERISTICS, $V_{DD} = V_{DDA} = 3.3V \pm 5\%$, $T_A = 0^\circ C$ TO $70^\circ C$, $R_{REF} = 475\Omega$

Symbol	Parameter	Test Conditions	Minimum	Typical	Maximum	Units
I_{IH}	Input High Current	CLK, nCLK	$V_{DD} = V_{IN} = 3.465V$		150	μA
I_{IL}	Input Low Current	CLK, nCLK	$V_{DD} = 3.465V, V_{IN} = 0V$		150	μA
V_{PP}	Peak-to-Peak Input Voltage		0.15		1.3	V
V_{CMR}	Common Mode Input Voltage; NOTE 1, 2		GND + 0.5		$V_{DD} - 0.85$	V

NOTE 1: Common mode voltage is defined as V_{IH} .

NOTE 2: For single ended applications, the maximum input voltage for CLK, nCLK is $V_{DD} + 0.3V$.

TABLE 4D. HCSL DC CHARACTERISTICS, $V_{DD} = V_{DDA} = 3.3V \pm 5\%$, $T_A = 0^\circ\text{C}$ TO 70°C , $R_{REF} = 475\Omega$

Symbol	Parameter	Test Conditions	Minimum	Typical	Maximum	Units
I_{OH}	Output Current		12	14	16	mA
V_{OH}	Output High Voltage		610		780	mV
V_{OL}	Output Low Voltage				65	mV
I_{OZ}	High Impedance Leakage Current		-10		10	μA
V_{OX}	Output Crossover Voltage		250		550	mV

TABLE 5. AC CHARACTERISTICS, $V_{DD} = V_{DDA} = 3.3V \pm 5\%$, $T_A = 0^\circ\text{C}$ TO 70°C , $R_{REF} = 475\Omega$

Symbol	Parameter	Test Conditions	Minimum	Typical	Maximum	Units
f_{MAX}	Output Frequency				140	MHz
$t_{sk(o)}$	Output Skew; NOTE 1, 2			50	110	ps
$t_{jit(cc)}$	Cycle-to-Cycle Jitter	Outputs @ Different Frequencies			110	ps
		Outputs @ Same Frequencies			50	ps
$t_{jit(\emptyset)}$	RMS Phase Jitter (Random); NOTE 3	Integration Range: 1.5MHz - 22MHz		2.42		ps
t_R / t_F	Output Rise/Fall Time	20% to 80%	300		1100	ps
odc	Output Duty Cycle		48		52	%

NOTE 1: Defined as skew between outputs at the same supply voltage and with equal load conditions. Measured at the output differential cross points.

NOTE 2: This parameter is defined in accordance with JEDEC Standard 65.

NOTE 3: Please refer to the Phase Noise Plot following this section.

TYPICAL PHASE NOISE AT 100MHz

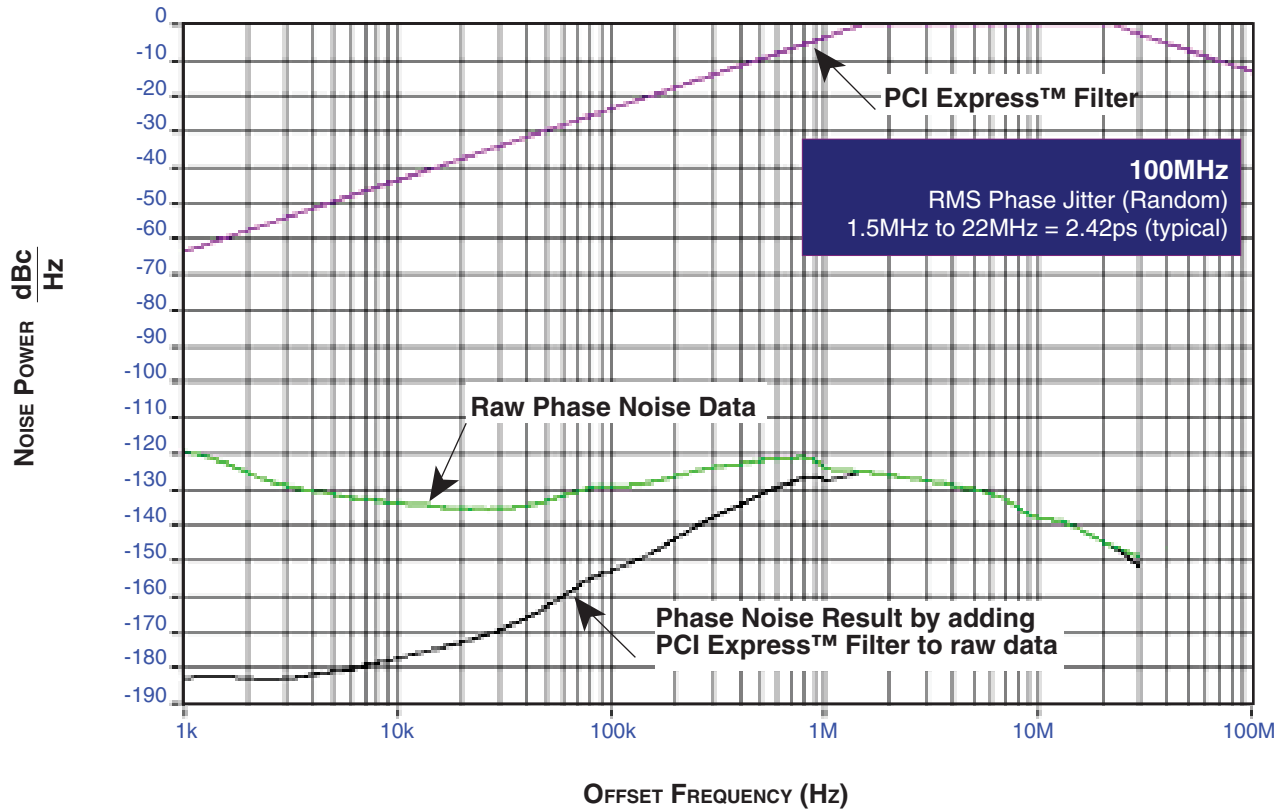

The illustrated phase noise plot was taken using a low phase noise signal generator, the noise floor of the signal generator is less than that of the device under test.

Using this configuration allows one to see the true spectral purity or phase noise performance of the PLL in the device under test. Due

to the tracking ability of a PLL, it will track the input signal up to its loop bandwidth. Therefore, if the input phase noise is greater than that of the PLL, it will increase the output phase noise performance of the device. It is recommended that the phase noise performance of the input is verified in order to achieve the above phase noise performance.

PARAMETER MEASUREMENT INFORMATION

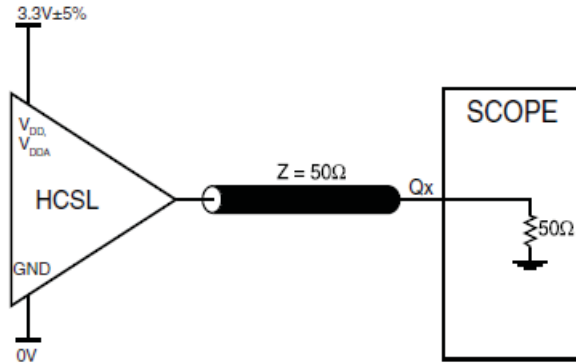
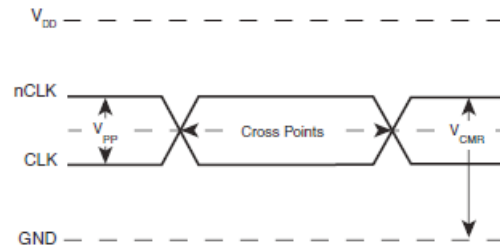
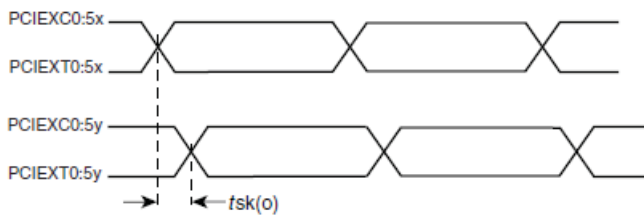
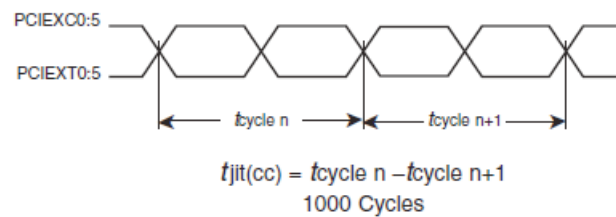
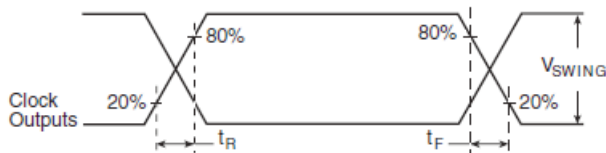
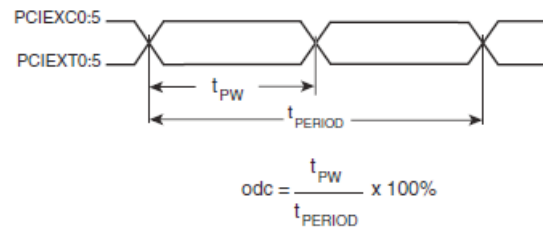
3.3V HCSL OUTPUT LOAD AC TEST CIRCUIT

DIFFERENTIAL INPUT LEVEL

OUTPUT SKEW

CYCLE-TO-CYCLE JITTER

OUTPUT RISE/FALL TIME

OUTPUT DUTY CYCLE/PULSE WIDTH/PERIOD

APPLICATION INFORMATION

POWER SUPPLY FILTERING TECHNIQUES

As in any high speed analog circuitry, the power supply pins are vulnerable to random noise. The 9DB206 provides separate power supplies to isolate any high switching noise from the outputs to the internal PLL. V_{DD} and V_{DDA} should be individually connected to the power supply plane through vias, and bypass capacitors should be used for each pin. To achieve optimum jitter performance, power supply isolation is required. *Figure 1* illustrates how a 24Ω resistor along with a $10\mu\text{F}$ and a $.01\mu\text{F}$ bypass capacitor should be connected to each V_{DDA} pin. The 10Ω resistor can also be replaced by a ferrite bead.

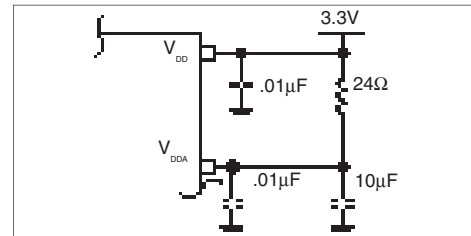

FIGURE 1. POWER SUPPLY FILTERING

WIRING THE DIFFERENTIAL INPUT TO ACCEPT SINGLE ENDED LEVELS

Figure 2 shows how the differential input can be wired to accept single ended levels. The reference voltage $V_{REF} = V_{DD}/2$ is generated by the bias resistors $R1$, $R2$ and $C1$. This bias circuit should be located as close as possible to the input pin. The ratio

of $R1$ and $R2$ might need to be adjusted to position the V_{REF} in the center of the input voltage swing. For example, if the input clock swing is only 2.5V and $V_{DD} = 3.3\text{V}$, V_{REF} should be 1.25V and $R2/R1 = 0.609$.

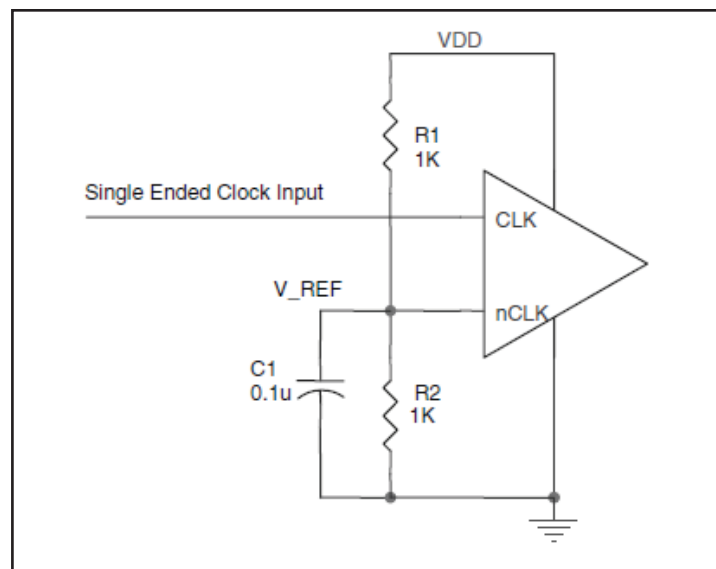

FIGURE 2. SINGLE ENDED SIGNAL DRIVING DIFFERENTIAL INPUT

DIFFERENTIAL CLOCK INPUT INTERFACE

The CLK/nCLK accepts LVDS, LVPECL, LVHSTL, SSTL, HCSL and other differential signals. Both V_{SWING} and V_{OH} must meet the V_{PP} and V_{CMR} input requirements. Figures 3A to 3D show interface examples for the HiPerClockS CLK/nCLK input driven by the most common driver types. The input interfaces suggested here are examples only.

Please consult with the vendor of the driver component to confirm the driver termination requirements. For example in *Figure 3A*, the input termination applies for ICS HiPerClockS LVHSTL drivers. If you are using an LVHSTL driver from another vendor, use their termination recommendation.

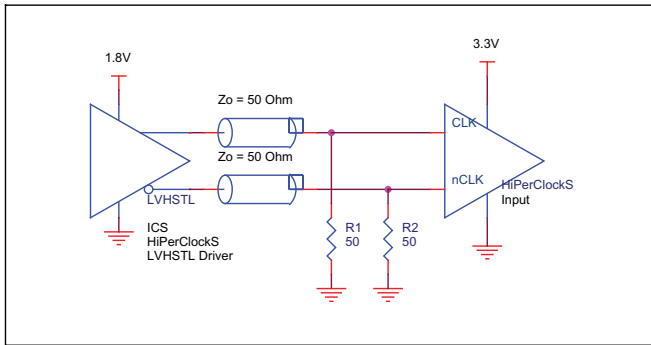

FIGURE 3A. HiPerClockS CLK/nCLK INPUT DRIVEN BY ICS HiPerClockS LVHSTL DRIVER

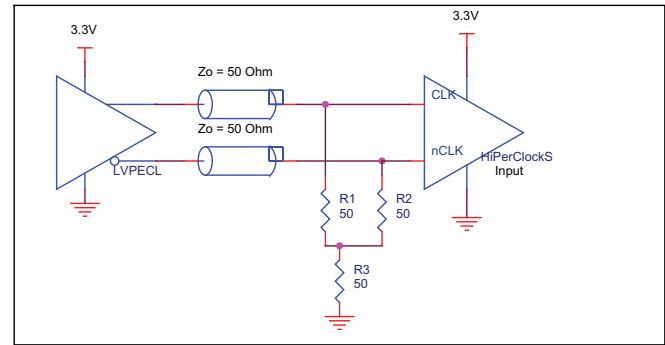

FIGURE 3B. HiPerClockS CLK/nCLK INPUT DRIVEN BY 3.3V LVPECL DRIVER

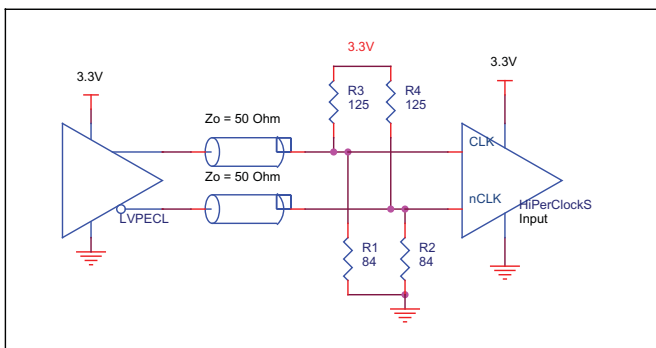

FIGURE 3C. HiPerClockS CLK/nCLK INPUT DRIVEN BY 3.3V LVPECL DRIVER

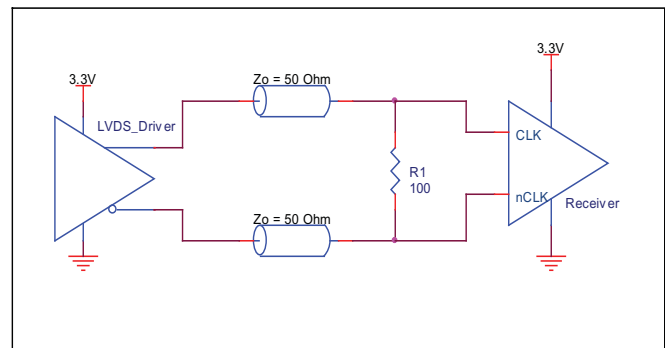

FIGURE 3D. HiPerClockS CLK/nCLK INPUT DRIVEN BY 3.3V LVDS DRIVER

RECOMMENDATIONS FOR UNUSED INPUT AND OUTPUT PINS

INPUTS:

LVC MOS CONTROL PINS:

All control pins have internal pull-ups or pull-downs; additional resistance is not required but can be added for additional protection. A 1k Ω resistor can be used.

OUTPUTS:

HCSL OUTPUT

All unused HCSL outputs can be left floating. We recommend that there is no trace attached. Both sides of the differential output pair should either be left floating or terminated.

SCHEMATIC EXAMPLE

The schematic below illustrates two different terminations. Both are reliable and adequate. The PCI Express termination is recommended for all PCI Express application. The optional termination, which

has a slightly better signal integrity, is recommended for all other applications.

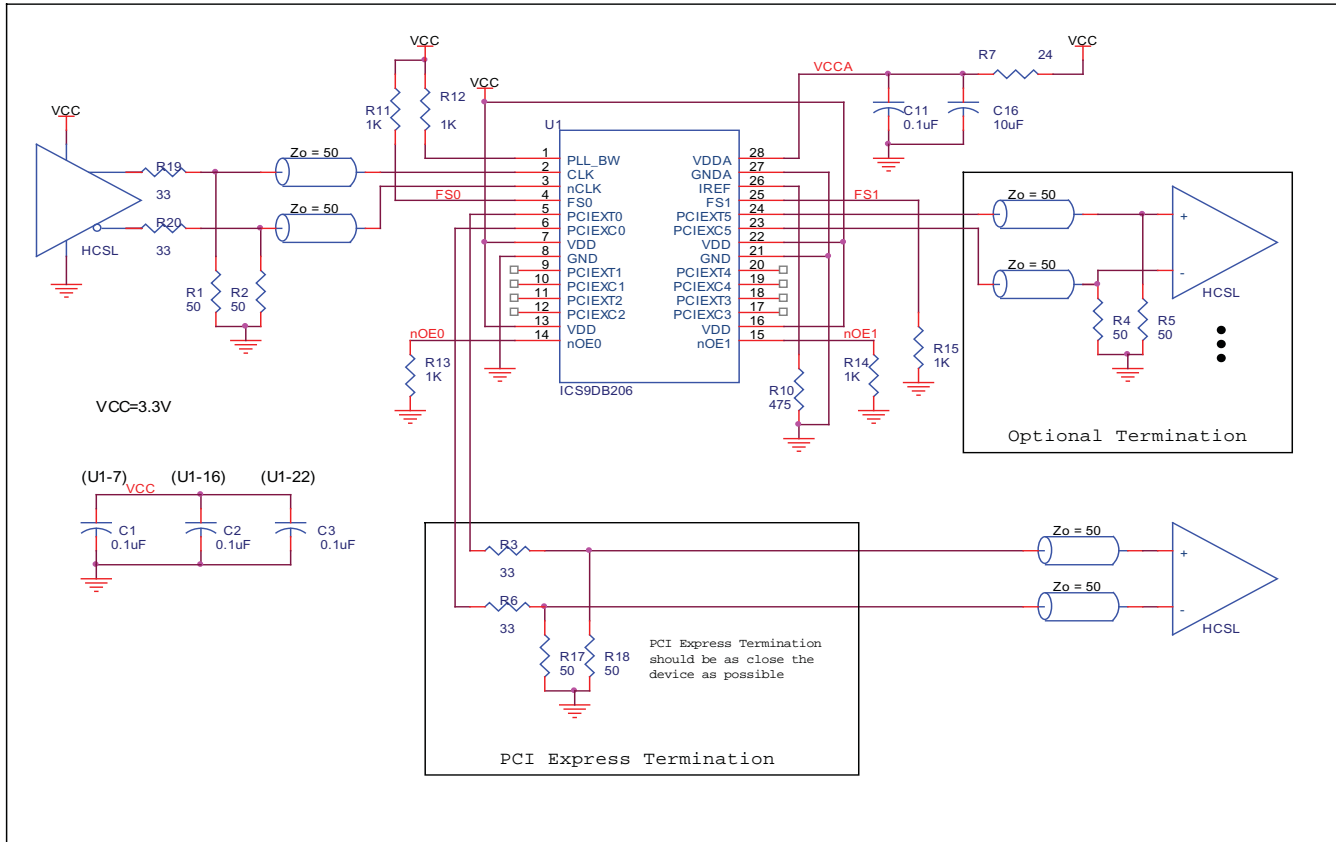

FIGURE 4. EXAMPLE OF 9DB206 SCHEMATIC

RELIABILITY INFORMATION

TABLE 6A. θ_{JA} vs. AIR FLOW TABLE FOR 28 LEAD TSSOP PACKAGE

θ_{JA} by Velocity (Linear Feet per Minute)			
	0	200	500
Single-Layer PCB, JEDEC Standard Test Boards	82.9°C/W	68.7°C/W	60.5°C/W
Multi-Layer PCB, JEDEC Standard Test Boards	49.8°C/W	43.9°C/W	41.2°C/W

NOTE: Most modern PCB designs use multi-layered boards. The data in the second row pertains to most designs.

TABLE 6B. θ_{JA} vs. AIR FLOW TABLE FOR 28 LEAD SSOP PACKAGE

θ_{JA} by Velocity (Linear Feet per Minute)			
	0	200	500
Multi-Layer PCB, JEDEC Standard Test Boards	49°C/W	36°C/W	30°C/W

TRANSISTOR COUNT

The transistor count for 9DB206 is: 2471

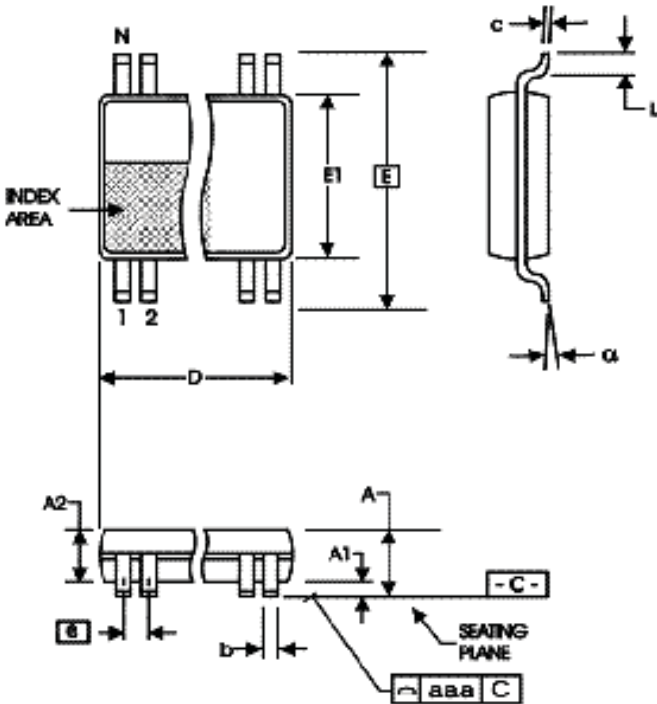
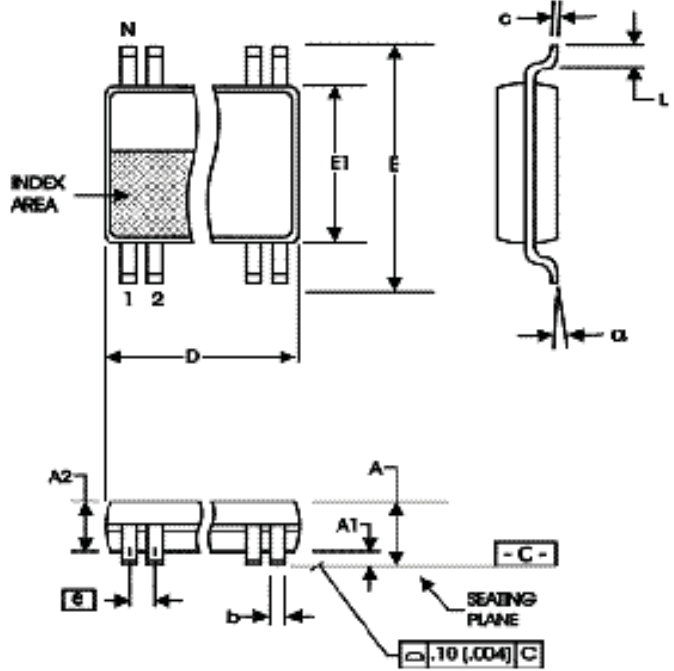
PACKAGE OUTLINE - G SUFFIX FOR 20 LEAD TSSOP

PACKAGE OUTLINE - F SUFFIX FOR 20 LEAD SSOP

TABLE 7A. PACKAGE DIMENSIONS

SYMBOL	Millimeters	
	Minimum	Maximum
N	20	
A	--	1.20
A1	0.05	0.15
A2	0.80	1.05
b	0.19	0.30
c	0.09	0.20
D	6.40	6.60
E	6.40 BASIC	
E1	4.30	4.50
e	0.65 BASIC	
L	0.45	0.75
α	0°	8°
aaa	--	0.10

Reference Document: JEDEC Publication 95, MO-153

TABLE 7B. PACKAGE DIMENSIONS

SYMBOL	Millimeters	
	Minimum	Maximum
N	20	
A	--	2.0
A1	0.05	--
A2	1.65	1.85
b	0.22	0.38
c	0.09	0.25
D	6.90	7.50
E	7.40	8.20
E1	5.0	5.60
e	0.65 BASIC	
L	0.55	0.95
α	0°	8°

Reference Document: JEDEC Publication 95, MO-150

TABLE 8. ORDERING INFORMATION

Part/Order Number	Marking	Package	Shipping Packaging	Temperature
9DB206CLLF	ICS9DB206CLLF	28 Lead "Lead-Free" TSSOP	Tube	0°C to 70°C
9DB206CLLFT	ICS9DB206CLLF	28 Lead "Lead-Free" TSSOP	Tape & Reel	0°C to 70°C
9DB206CFLF	ICS9DB206CFLF	28 Lead "Lead-Free" SSOP	Tube	0°C to 70°C
9DB206CFLFT	ICS9DB206CFLF	28 Lead "Lead-Free" SSOP	Tape & Reel	0°C to 70°C

REVISION HISTORY SHEET				
Rev	Table	Page	Description of Change	Date
A	T7	12	Ordering Information Table - added Lead-Free marking for TSSOP package.	11/29/04
B	T4D	4	HCSL Table -adjusted V_{OH} min from 680mV to 610mV and added V_{OH} max.	12/21/04
B	T7	12	Ordering Information Table - added Lead-Free marking for SSOP package.	3/21/05
B		1 8	Features Section - added Input Frequency Range and VCO Range bullets. Added <i>Recommendations for Unused Input and Output Pins</i> .	7/14/06
B	T8	12	Ordering Information - removed leaded devices. Updated data sheet format.	7/22/15
B	T8	12	Ordering Information - Deleted LF note below table. Updated header and footer.	2/18/16
B		1	Product Discontinuation Notice - Last time buy expires September 7, 2016. PDN N-16-02	3/11/16



Corporate Headquarters
6024 Silver Creek Valley Road
San Jose, CA 95138 USA
www.IDT.com

Sales
1-800-345-7015 or 408-284-8200
Fax: 408-284-2775
www.IDT.com/go/sales

Tech Support
www.idt.com/go/support

DISCLAIMER Integrated Device Technology, Inc. (IDT) reserves the right to modify the products and/or specifications described herein at any time, without notice, at IDT's sole discretion. Performance specifications and operating parameters of the described products are determined in an independent state and are not guaranteed to perform the same way when installed in customer products. The information contained herein is provided without representation or warranty of any kind, whether express or implied, including, but not limited to, the suitability of IDT's products for any particular purpose, an implied warranty of merchantability, or non-infringement of the intellectual property rights of others. This document is presented only as a guide and does not convey any license under intellectual property rights of IDT or any third parties.

IDT's products are not intended for use in applications involving extreme environmental conditions or in life support systems or similar devices where the failure or malfunction of an IDT product can be reasonably expected to significantly affect the health or safety of users. Anyone using an IDT product in such a manner does so at their own risk, absent an express, written agreement by IDT.

Integrated Device Technology, IDT and the IDT logo are trademarks or registered trademarks of IDT and its subsidiaries in the United States and other countries. Other trademarks used herein are the property of IDT or their respective third party owners.

For datasheet type definitions and a glossary of common terms, visit www.idt.com/go/glossary.

Copyright ©2016 Integrated Device Technology, Inc. All rights reserved.

Looking for pricing, stock, or lifecycle information?

Click below to explore more details on WIN SOURCE:

-  [View ICS9DB206CFLFT on WIN SOURCE](#)
-  [IDT, Integrated Device Technology Inc Information](#)

Optimize Your Supply Chain with WIN SOURCE Solutions

-  Global Sourcing Solution
-  Obsolete Management
-  Cost Control Management
-  Shortage Management
-  Alternative Solution
-  Excess Inventory Management