



**THE DATASHEET OF
ICS97ULP877AHLF**





1.8V Low-Power Wide-Range Frequency Clock Driver

Recommended Application:

- DDR2 Memory Modules / Zero Delay Board Fan Out
- Provides complete DDR DIMM logic solution with ICSSTU32864/SSTUF32864/SSTUF32866/SSTUA32864/SSTUA32866/SSTUA32S868/SSTUA32S865/SSTUA32S869

Product Description/Features:

- Low skew, low jitter PLL clock driver
- 1 to 10 differential clock distribution (SSTL_18)
- Feedback pins for input to output synchronization
- Spread Spectrum tolerant inputs
- Auto PD when input signal is at a certain logic state

Switching Characteristics:

- Period jitter: 40ps (DDR2-400/533)
30ps (DDR2-667)
- Half-period jitter: 60ps (DDR2-400/533)
50ps (DDR2-667)
- OUTPUT - OUTPUT skew: 40ps (DDR2-400/533)
30ps (DDR2-667)
- CYCLE - CYCLE jitter 40ps

Pin Configuration

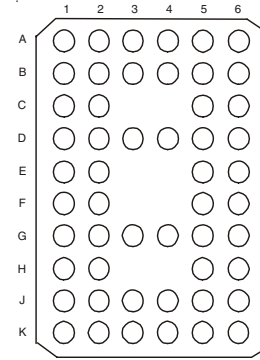

52-Ball BGA

Top View

	1	2	3	4	5	6
A	CLKT1	CLKT0	CLKC0	CLKC5	CLKT5	CLKT6
B	CLKC1	GND	GND	GND	GND	CLKC6
C	CLKC2	GND	NB	NB	GND	CLKC7
D	CLKT2	VDDQ	VDDQ	VDDQ	OS	CLKT7
E	CLK_INT	VDDQ	NB	NB	VDDQ	FB_INT
F	CLK_INC	VDDQ	NB	NB	OE	FB_INC
G	AGND	VDDQ	VDDQ	VDDQ	VDDQ	FB_OUTC
H	AVDD	GND	NB	NB	GND	FB_OUTT
J	CLKT3	GND	GND	GND	GND	CLKT8
K	CLKC3	CLKC4	CLKT4	CLKT9	CLKC9	CLKC8

Block Diagram

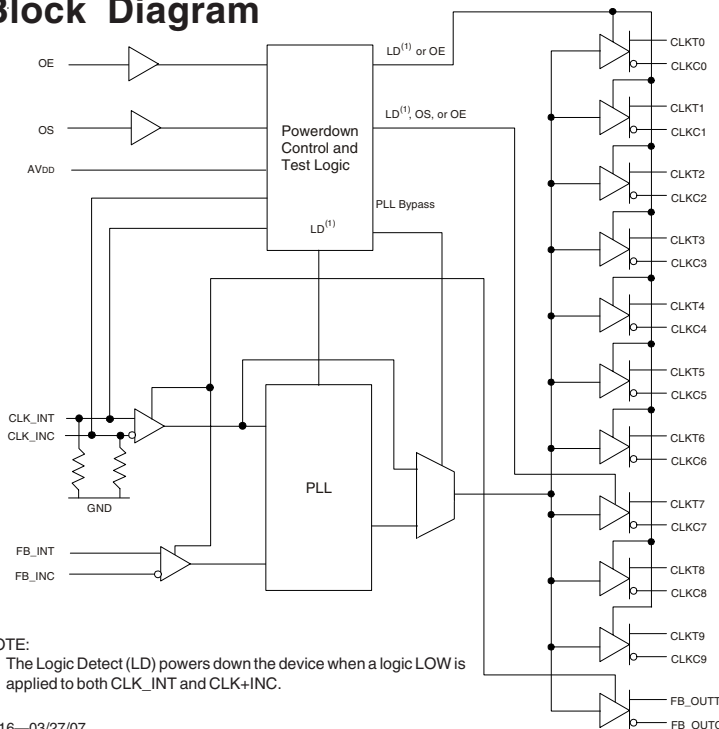

NOTE:
1. The Logic Detect (LD) powers down the device when a logic LOW is applied to both CLK_INT and CLK+INC.

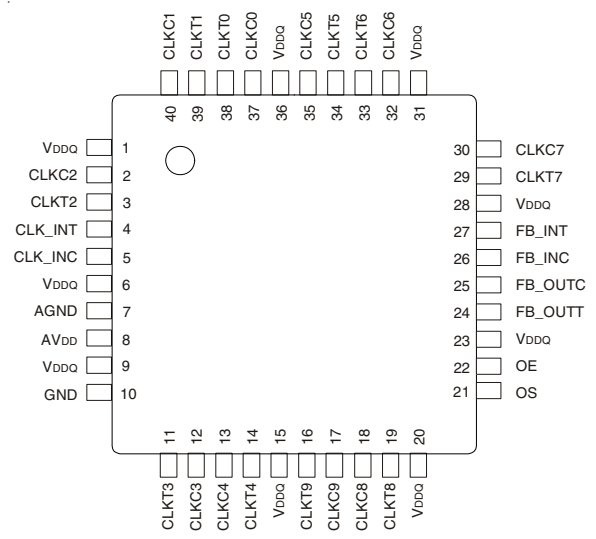

40-Pin MLF



Pin Descriptions

Terminal Name	Description	Electrical Characteristics
AGND	Analog Ground	Ground
AV _{DD}	Analog power	1.8 V nominal
CLK_INT	Clock input with a (10K-100K Ohm) pulldown resistor	Differential input
CLK_INC	Complementary clock input with a (10K-100K Ohm) pulldown resistor	Differential input
FB_INT	Feedback clock input	Differential input
FB_INC	Complementary feedback clock input	Differential input
FB_OUTT	Feedback clock output	Differential output
FB_OUTC	Complementary feedback clock output	Differential output
OE	Output Enable (Asynchronous)	LVC MOS input
OS	Output Select (tied to GND or V _{DDQ})	LVC MOS input
GND	Ground	Ground
V _{DDQ}	Logic and output power	1.8V nominal
CLKT[0:9]	Clock outputs	Differential outputs
CLKC[0:9]	Complementary clock outputs	Differential outputs
NB	No ball	

The PLL clock buffer, **ICS97ULP877A**, is designed for a V_{DDQ} of 1.8 V, a AV_{DD} of 1.8 V and differential data input and output levels. Package options include a plastic 52-ball VFBGA and a 40-pin MLF.

ICS97ULP877A is a zero delay buffer that distributes a differential clock input pair (CLK_INT, CLK_INC) to ten differential pair of clock outputs (CLKT[0:9], CLKC[0:9]) and one differential pair feedback clock outputs (FB_OUTT, FB_OUTC). The clock outputs are controlled by the input clocks (CLK_INT, CLK_INC), the feedback clocks (FB_INT, FB_INC), the LVC MOS program pins (OE, OS) and the Analog Power input (AV_{DD}). When OE is low, the outputs (except FB_OUTT/FB_OUTC) are disabled while the internal PLL continues to maintain its locked-in frequency. OS (Output Select) is a program pin that must be tied to GND or V_{DDQ}. When OS is high, OE will function as described above. When OS is low, OE has no effect on CLKT7/CLKC7 (they are free running in addition to FB_OUTT/FB_OUTC). When AV_{DD} is grounded, the PLL is turned off and bypassed for test purposes.

When both clock signals (CLK_INT, CLK_INC) are logic low, the device will enter a low power mode. An input logic detection circuit on the differential inputs, independent from the input buffers, will detect the logic low level and perform a low power state where all outputs, the feedback and the PLL are OFF. When the inputs transition from both being logic low to being differential signals, the PLL will be turned back on, the inputs and outputs will be enabled and the PLL will obtain phase lock between the feedback clock pair (FB_INT, FB_INC) and the input clock pair (CLK_INT, CLK_INC) within the specified stabilization time t_{STAB}.

The PLL in **ICS97ULP877A** clock driver uses the input clocks (CLK_INT, CLK_INC) and the feedback clocks (FB_INT, FB_INC) to provide high-performance, low-skew, low-jitter output differential clocks (CLKT[0:9], CLKC[0:9]). **ICS97ULP877A** is also able to track Spread Spectrum Clocking (SSC) for reduced EMI.

ICS97ULP877A is characterized for operation from 0°C to 70°C.



Function Table

Inputs					Outputs				PLL
AVDD	OE	OS	CLK_INT	CLK_INT	CLKT	CLKC	FB_OUTT	FB_OUTC	
GND	H	X	L	H	L	H	L	H	Bypassed/Off
GND	H	X	H	L	H	L	H	L	Bypassed/Off
GND	L	H	L	H	*L(Z)	*L(Z)	L	H	Bypassed/Off
GND	L	L	H	L	*L(Z), CLKT7 active	*L(Z), CLKC7 active	H	L	Bypassed/Off
1.8V(nom)	L	H	L	H	*L(Z)	*L(Z)	L	H	On
1.8V(nom)	L	L	H	L	*L(Z), CLKT7 active	*L(Z), CLKC7 active	H	L	On
1.8V(nom)	H	X	L	H	L	H	L	H	On
1.8V(nom)	H	X	H	L	H	L	H	L	On
1.8V(nom)	X	X	L	L	*L(Z)	*L(Z)	*L(Z)	*L(Z)	Off
1.8V(nom)	X	X	H	H	Reserved				

*L(Z) means the outputs are disabled to a low stated meeting the I_{ODL} limit.



Absolute Maximum Ratings

Supply Voltage (VDDQ & AVDD)	-0.5V to 2.5V
Logic Inputs	GND - 0.5V to V _{DDQ} + 0.5V
Ambient Operating Temperature	0°C to +70°C
Storage Temperature	-65°C to +150°C

Stresses above those listed under *Absolute Maximum Ratings* may cause permanent damage to the device. These ratings are stress specifications only and functional operation of the device at these or any other conditions above those listed in the operational sections of the specifications is not implied. Exposure to absolute maximum rating conditions for extended periods may affect product reliability.

Electrical Characteristics - Input/Supply/Common Output Parameters

TA = 0 - 70°C; Supply Voltage AVDDQ, VDDQ = 1.8 V +/- 0.1V (unless otherwise stated)

PARAMETER	SYMBOL	CONDITIONS	MIN	TYP	MAX	UNITS
Input High Current (CLK_INT, CLK_INC)	I _{IH}	V _I = V _{DDQ} or GND			±250	µA
Input Low Current (OE, OS, FB_INT, FB_INC)	I _{IL}	V _I = V _{DDQ} or GND			±10	µA
Output Disabled Low Current	I _{ODL}	OE = L, V _{ODL} = 100mV	100			µA
Operating Supply Current	I _{DD1.8}	C _L = 0pf @ 270MHz			200	mA
	I _{DDLD}	C _L = 0pf			500	µA
Input Clamp Voltage	V _{IK}	V _{DDQ} = 1.7V I _{in} = -18mA			-1.2	V
High-level output voltage	V _{OH}	I _{OH} = -100 A	V _{DDQ} - 0.2			V
		I _{OH} = -9 mA	1.1	1.45		V
Low-level output voltage	V _{OL}	I _{OL} = 100 A		0.25	0.10	V
		I _{OL} = 9 mA			0.6	V
Input Capacitance ¹	C _{IN}	V _I = GND or V _{DDQ}	2		3	pF
Output Capacitance ¹	C _{OUT}	V _{OUT} = GND or V _{DDQ}	2		3	pF

¹Guaranteed by design, not 100% tested in production.

**Recommended Operating Condition** (see note1)T_A = 0 - 70°C; Supply Voltage AVDD, VDDQ = 1.8 V +/- 0.1V (unless otherwise stated)

PARAMETER	SYMBOL	CONDITIONS	MIN	TYP	MAX	UNITS
Supply Voltage	V _{DDQ} , A _{VDD}		1.7	1.8	1.9	V
Low level input voltage	V _{IL}	CLK_INT, CLK_INC, FB_INC, FB_INT			0.35 x V _{DDQ}	V
		OE, OS			0.35 x V _{DDQ}	V
High level input voltage	V _{IH}	CLK_INT, CLK_INC, FB_INC, FB_INT	0.65 x V _{DDQ}			V
		OE, OS	0.65 x V _{DDQ}			V
DC input signal voltage (note 2)	V _{IN}		-0.3		V _{DDQ} + 0.3	V
Differential input signal voltage (note 3)	V _{ID}	DC - CLK_INT, CLK_INC, FB_INC, FB_INT	0.3		V _{DDQ} + 0.4	V
		AC - CLK_INT, CLK_INC, FB_INC, FB_INT	0.6		V _{DDQ} + 0.4	V
Output differential cross-voltage (note 4)	V _{OX}		V _{DDQ} /2 - 0.10		V _{DDQ} /2 + 0.10	V
Input differential cross-voltage (note 4)	V _{IX}		V _{DDQ} /2 - 0.15	V _{DD} /2	V _{DDQ} /2 + 0.15	V
High level output current	I _{OH}				-9	mA
Low level output current	I _{OL}				9	mA
Operating free-air temperature	T _A		0		70	°C

Notes:

- Unused inputs must be held high or low to prevent them from floating.
- DC input signal voltage specifies the allowable DC execution of differential input.
- Differential inputs signal voltages specifies the differential voltage [VTR-VCP] required for switching, where VTR is the true input level and VCP is the complementary input level.
- Differential cross-point voltage is expected to track variations of V_{DDQ} and is the voltage at which the differential signal must be crossing.



Timing Requirements

$T_A = 0 - 70^\circ\text{C}$ Supply Voltage AVDD, VDDQ = 1.8 V +/- 0.1V (unless otherwise stated)

PARAMETER	SYMBOL	CONDITIONS	MIN	MAX	UNITS
Max clock frequency	freq _{op}	1.8V±0.1V @ 25°C	95	410	MHz
Application Frequency Range	freq _{App}	1.8V±0.1V @ 25°C	160	350	MHz
Input clock duty cycle	d _{tin}		40	60	%
CLK stabilization	T _{STAB}			15	μs

NOTE: The PLL must be able to handle spread spectrum induced skew.

NOTE: Operating clock frequency indicates a range over which the PLL must be able to lock, but in which it is not required to meet the other timing parameters. (Used for low speed system debug.)

NOTE: Application clock frequency indicates a range over which the PLL must meet all timing parameters.

NOTE: Stabilization time is the time required for the integrated PLL circuit to obtain phase lock of its feedback signal to its reference signal, within the value specified by the Static Phase Offset (t_{AE}), after power-up. During normal operation, the stabilization time is also the time required for the integrated PLL circuit to obtain phase lock of its feedback signal to its reference signal when CK and CK go to a logic low state, enter the power-down mode and later return to active operation. CK and CK may be left floating after they have been driven low for one complete clock cycle.



Switching Characteristics¹

T_A = 0 - 70°C Supply Voltage AVDD, VDDQ = 1.8 V +/- 0.1V (unless otherwise stated)

PARAMETER	SYMBOL	CONDITION	(MHz)	MIN	TYP	MAX	UNITS	
Output enable time	t _{en}	OE to any output	160 to 410		4.73	8	ns	
Output disable time	t _{dis}	OE to any output			5.82	8	ns	
Period jitter	t _{jit(per)}		160 to 270	-40		40	ps	
			271 to 410	-30		30	ps	
Half-period jitter	t _{jit(hper)}		160 to 270	-60		60	ps	
			271 to 410	-50		50	ps	
Input slew rate	SLr1(i)	Input Clock	160 to 410	1	2.5	4	v/ns	
		Output Enable (OE), (OS)		0.5			v/ns	
Output clock slew rate	SLr1(o)	1.5		2.5	3	v/ns		
Cycle-to-cycle period jitter	t _{jit(cc+)}	0			40	ps		
	t _{jit(cc-)}	0			-40	ps		
Dynamic Phase Offset	t _{(∅)dyn}			160 to 270	-50		50	ps
				271 to 410	-20		20	ps
Static Phase Offset	t _{SPO} ²			271 to 410	-50	0	50	ps
t _{jit(per)} + t _{(∅)dyn} + t _{skew(o)}	∑(su)						80	ps
t _{(∅)dyn} + t _{skew(o)}	∑t(h)						60	ps
Output to Output Skew	t _{skew}		160 to 270			40	ps	
			271 to 410			30	ps	
SSC modulation frequency				30.00		33	kHz	
SSC clock input frequency deviation				0.00		-0.50	%	
PLL Loop bandwidth (-3 dB from unity gain)				2.0			MHz	

Notes:

1. Switching characteristics guaranteed for application frequency range.
2. Static phase offset shifted by design.



Parameter Measurement Information

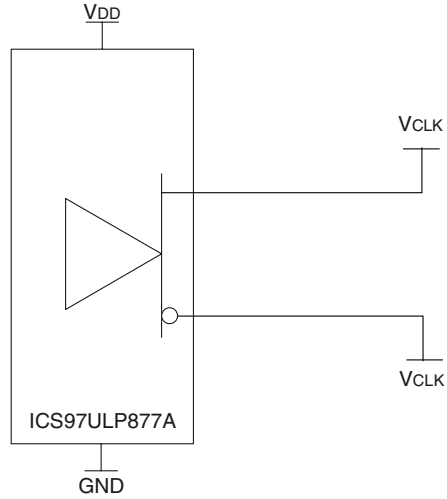

IBIS Model Output Load

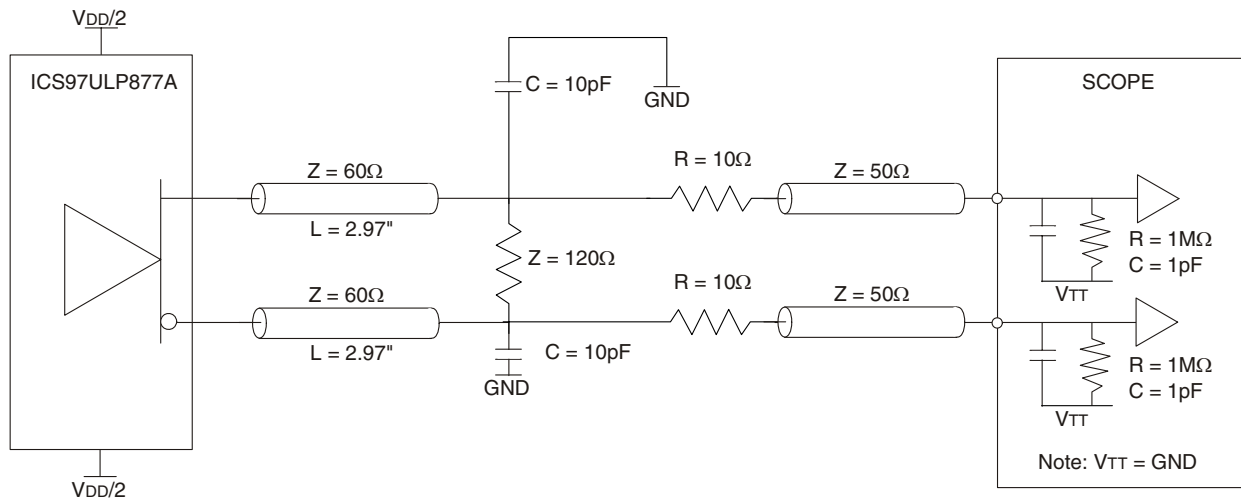

Output Load Test Circuit

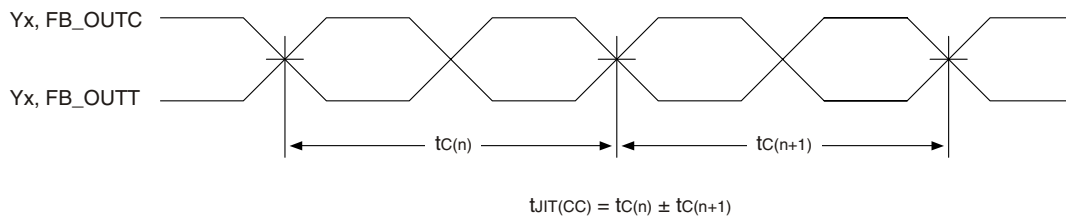

Cycle-to-Cycle Jitter



Parameter Measurement Information

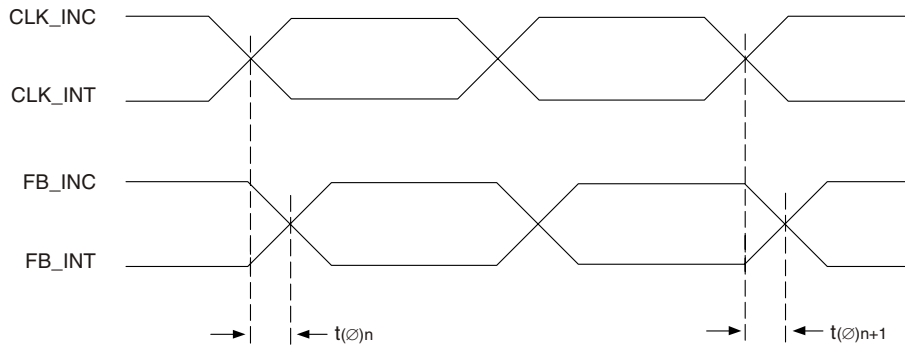

$$t(\phi) = \frac{\sum_{n=1}^{n=N} t(\phi)n}{n}$$

(N is a large number of samples)

Static Phase Offsel

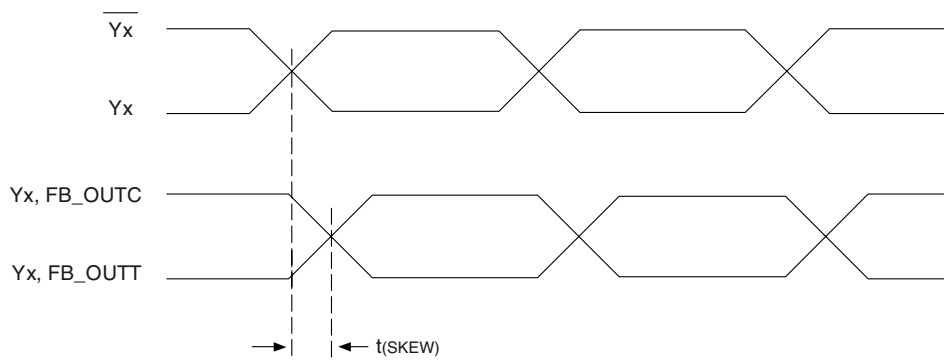

Output Skew

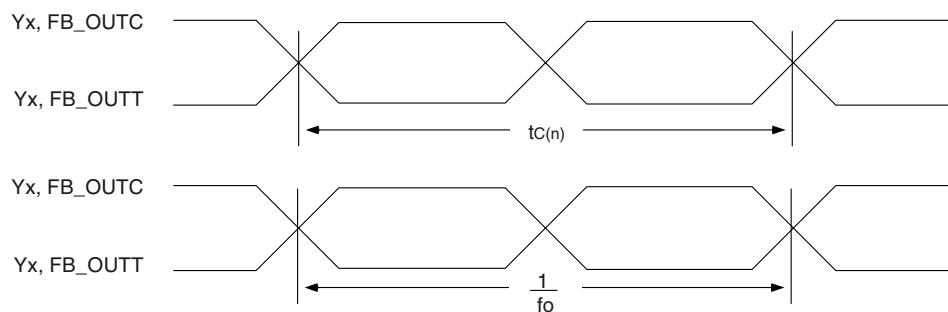

$$t(JIT_PER) = tC(n) - \frac{1}{fo}$$

Period Jitter



Parameter Measurement Information

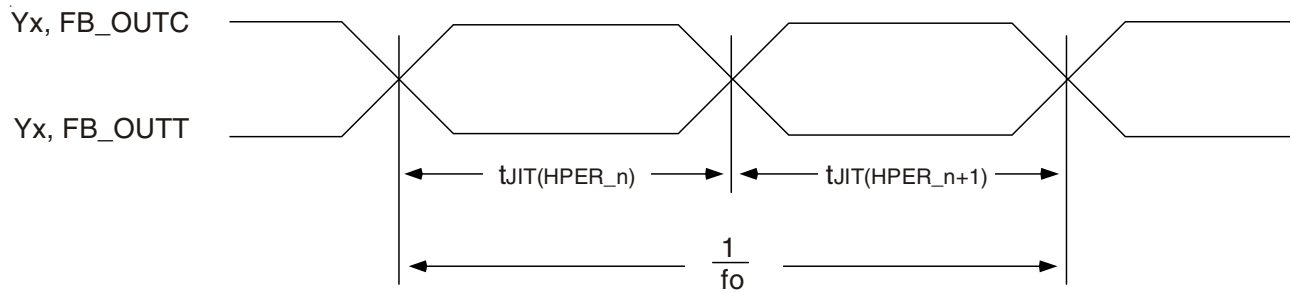

$$t_{JIT}(HPER) = t_{JIT}(HPER_n) - \frac{1}{2xfo}$$

Half-Period Jitter

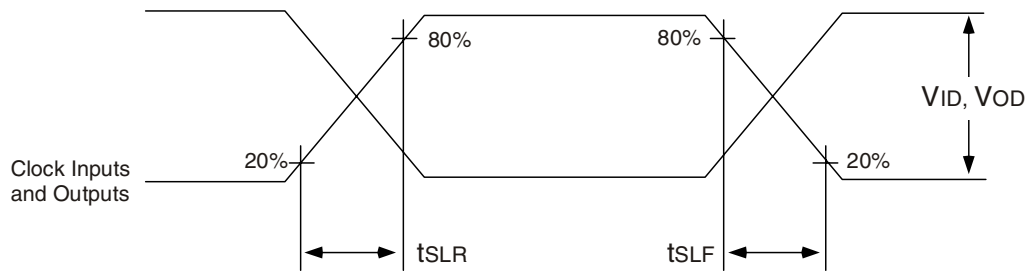

Input and Output Skew Rates



Parameter Measurement Information

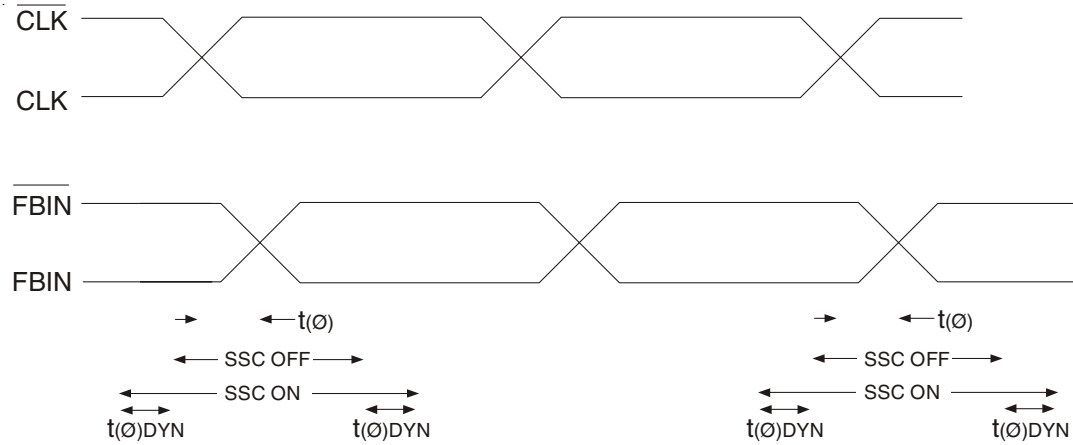

Dynamic Phase Offset

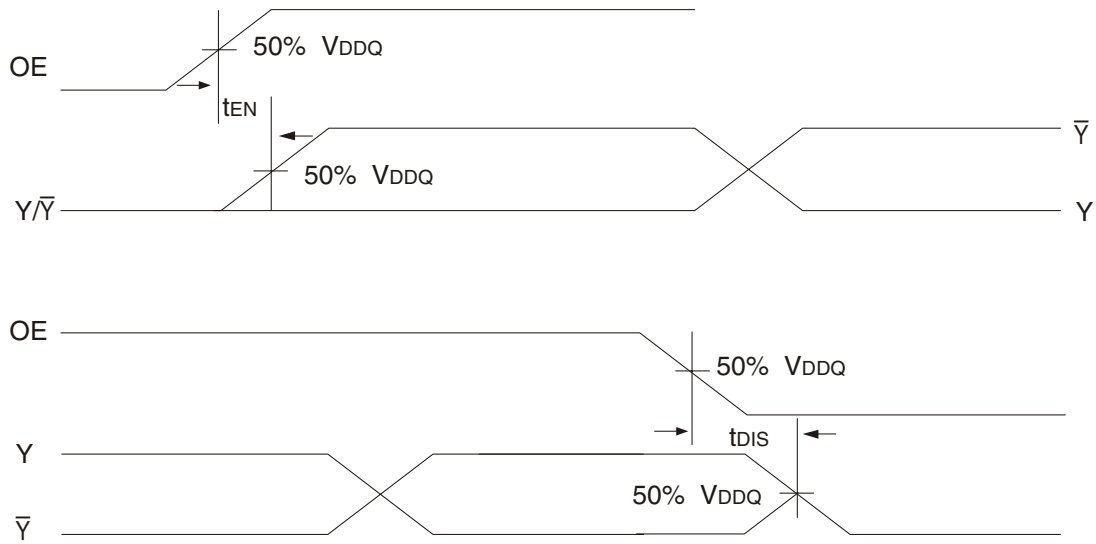

Time Delay Between OE and Clock Output (Y, \bar{Y})

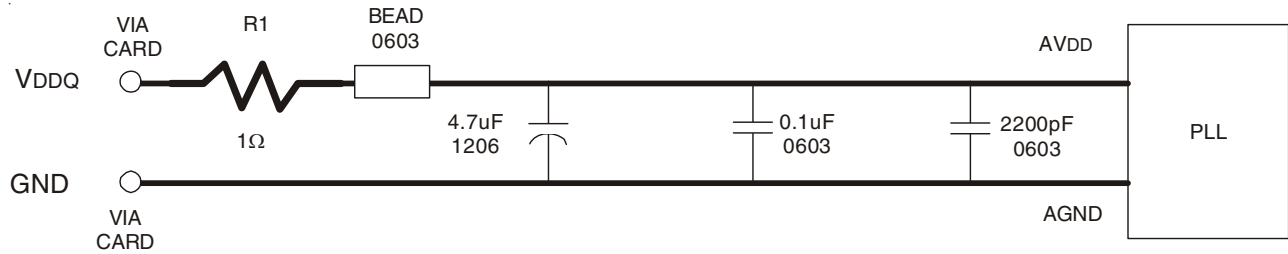

AVDD Filtering

- Place the 2200pF capacitor close to the PLL.
- Use a wide trace for the PLL analog power & ground. Connect PLL & caps to AGND trace & connect trace to one GND via (farthest from PLL).
- Recommended bead: Fair-Rite P/N 2506036017Y0 or equivalent (0.8 Ohm DC max, 600 Ohms @ 100 MHz).

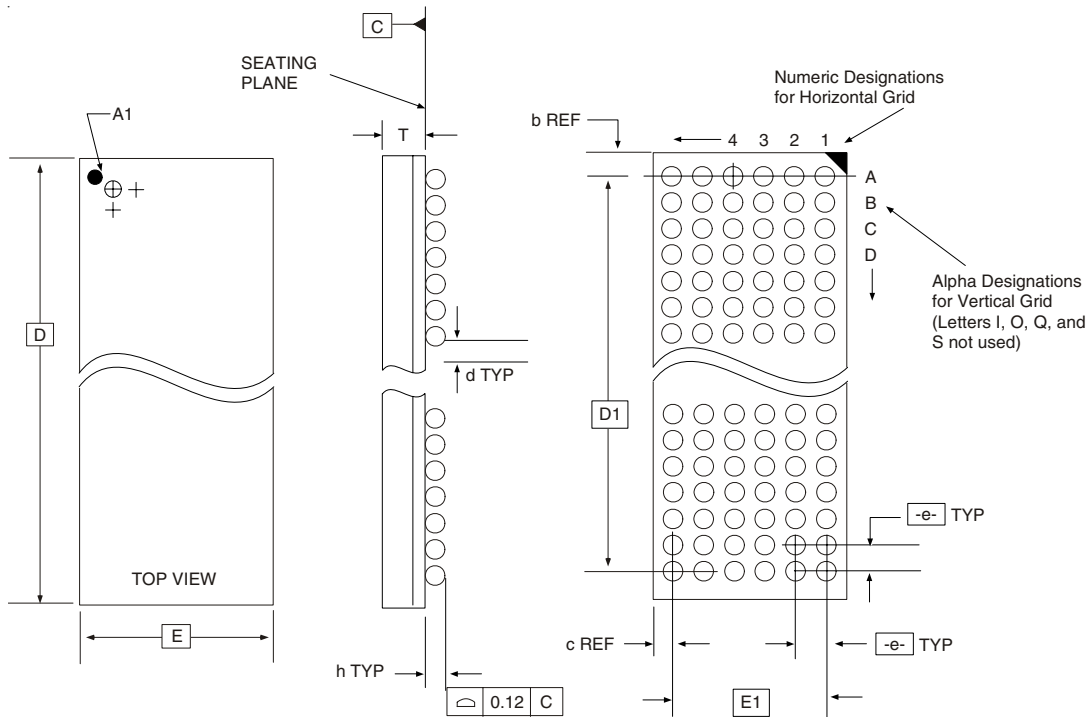

ALL DIMENSIONS IN MILLIMETERS

D	E	T Min/Max	e	BALL GRID		Max. TOTAL	d Min/Max	h Min/Max	D1	E1	REF. DIMENSIONS	
				HORIZ	VERT						b	c
7.00 Bsc	4.50 Bsc	0.86/1.00	0.65 Bsc	6	10	60	0.35/0.45	0.15/0.21	5.85 Bsc	3.25 Bsc	0.575	0.625

Note: Ball grid total indicates maximum ball count for package. Lesser quantity may be used.

* Source Ref.: JEDEC Publication 95, MO-205*, MO-225**

10-0055

Ordering Information

ICS97ULP877AHLF-T

Example:

ICS XXXX y H LF- T

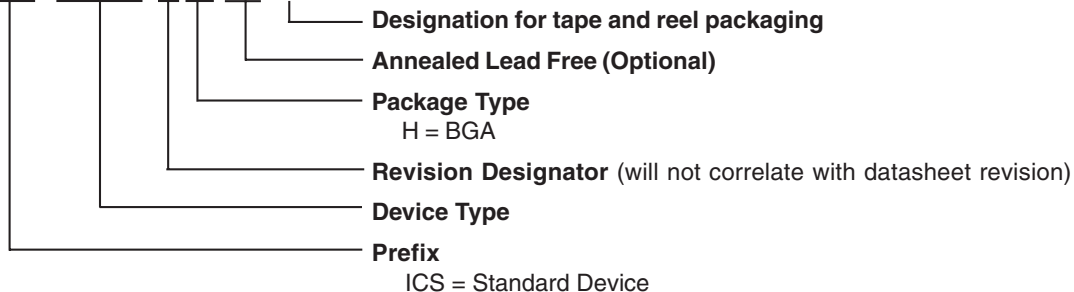

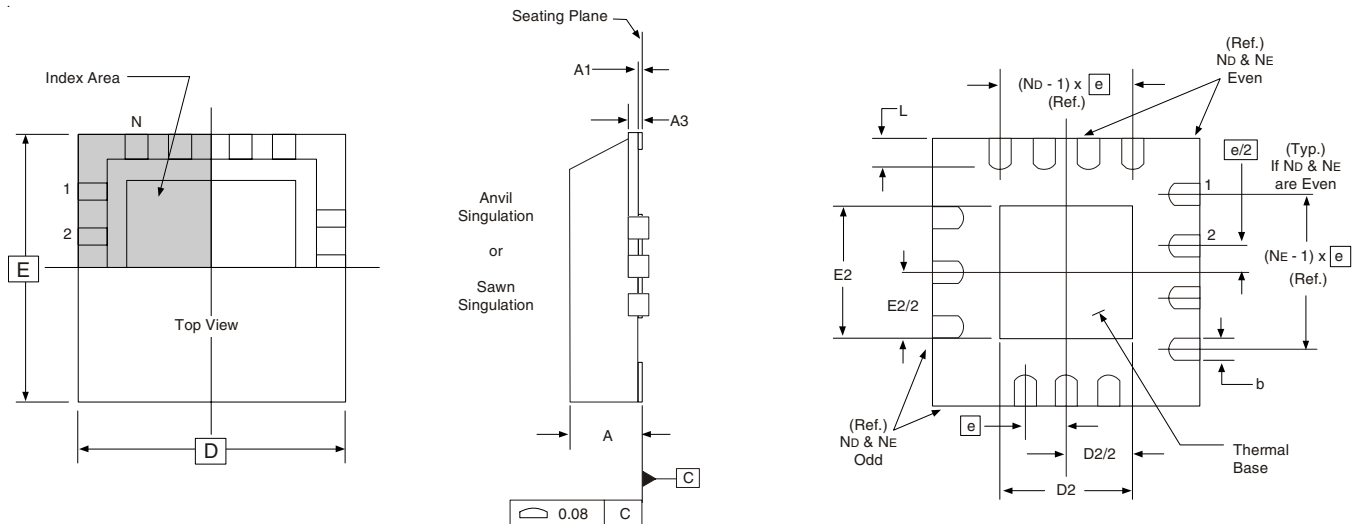

THERMALLY ENHANCED, VERY THIN, FINE PITCH QUAD FLAT / NO LEAD PLASTIC PACKAGE

ALL DIMENSIONS IN MILLIMETERS

N	40	SYMBOL	MIN.	MAX.
N_D	10	A	0.80	1.00
N_E	10	A1	0	0.05
D x E BASIC	6.00 x 6.00	A3	0.25 Reference	
D2 MIN. / MAX.	2.75 / 3.05	b	0.18	0.30
E2 MIN. / MAX.	2.75 / 3.05	e	0.50 BASIC	
L MIN. / MAX.	0.30 / 0.50			

Source Reference: MLF2™SI
10-0053

Ordering Information

ICS97ULP877AKLF-T

Example:

ICS XXXX y K LF-T

- Designation for tape and reel packaging
- Annealed Lead Free (Optional)
- Package Type
K = MLF
- Revision Designator (will not correlate with datasheet revision)
- Device Type
- Prefix
ICS = Standard Device

Looking for pricing, stock, or lifecycle information?

Click below to explore more details on WIN SOURCE:

- ⊖ [View ICS97ULP877AHLF on WIN SOURCE](#)
- ⊖ [IDT, Integrated Device Technology Inc Information](#)

Optimize Your Supply Chain with WIN SOURCE Solutions

- ✓ Global Sourcing Solution
- ✓ Obsolete Management
- ✓ Cost Control Management
- ✓ Shortage Management
- ✓ Alternative Solution
- ✓ Excess Inventory Management