

Single phase 250Vac 3 to 300A EMC Filters with DIN rail mount and low leakage options

https://product.tdk.com/en/products/emc/emc/power-line/tec_data/tdk_nf_rshn.html

<https://www.emea.lambda.tdk.com/uk/products/r-series>

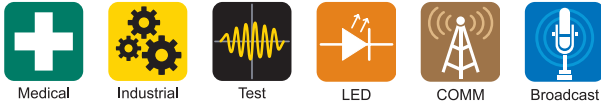

The RSHN single-phase high attenuation EMC filters are enclosed in compact cases and part numbers up to 30A have DIN rail mount and low leakage current options. They are rated for 250Vac with multiple current ratings of 3 to 300A enabling the optimum attenuation to match the current rating. The series uses TDK's ferrite core material to provide noise attenuation. The connection terminals are integrated into the case with both the screws and terminal covers captive, avoiding dropped or lost hardware. The RSHN 3A to 30A models are UL certified for a short circuit current rating of up to 14kA, the 40, 50 and 60A 35kA with the appropriate breaker.

Features	Benefits
• 3 to 300A Current Ratings	• Optimizes the Attenuation for the Current Rating
• DIN Rail Mount Option	• Flexible Mounting
• Captive Hardware	• No Lost Screws or Terminal Covers
• Safety Certified (up to 60A)	• Global Use

Model Selector								
Model	Rated Current (A)	SCCR (kA) ⁽¹⁾	Leakage Current 250V/60Hz (mA)	Maximum DC Resistance (mΩ)	Attenuation frequency range (MHz)			Weight (g)
					Common mode at 25dB	Common mode at 10dB	Differential mode at 25dB	
RSHN-2003	3	14	1.0	350	0.1 to 10	-	0.2 to 30	190
RSHN-2006	6	14	1.0	140	0.1 to 10	-	0.2 to 30	240
RSHN-2010	10	14	1.0	60	0.1 to 30	-	0.3 to 30	240
RSHN-2016	16	14	1.0	35	0.2 to 30	-	0.3 to 30	350
RSHN-2020	20	14	1.0	22	0.2 to 30	-	0.4 to 30	350
RSHN-2030	30	14	1.0	12	0.3 to 30	-	0.6 to 30	350
RSHN-2040	40	35	1.0	10	0.2 to 30	-	0.1 to 30	1500
RSHN-2050	50	35	1.0	8	0.3 to 30	-	0.2 to 30	1400
RSHN-2060	60	35	1.0	6	0.3 to 30	-	0.3 to 30	1400
RSHN-2080	80	-	1.0	7	0.2 to 8	-	0.1 to 30	5500
RSHN-2100	100	-	1.0	6	0.2 to 8	-	0.1 to 30	6000
RSHN-2150	150	-	1.0	4	0.2 to 7	-	0.1 to 30	9000
RSHN-2200	200	-	1.0	3	0.4 to 7	-	0.1 to 30	13000
RSHN-2250	250	-	1.0	2	-	0.4 to 10	0.1 to 30	13000
RSHN-2300	300	-	1.0	1.5	-	1 to 7	0.1 to 30	13000

Model Selector								
Model	Rated Current (A)	SCCR (kA) ⁽¹⁾	Leakage Current 250V/60Hz (mA)	Maximum DC Resistance (mΩ)	Attenuation frequency range (MHz)		Weight (g)	
					Common mode at 25dB	Common mode at 25dB		
RSHN-2003L	3	14	0.10	350	0.2 to 10	0.2 to 30	190	
RSHN-2006L	6	14	0.10	140	0.2 to 10	0.2 to 30	240	
RSHN-2010L	10	14	0.10	60	0.3 to 10	0.3 to 30	240	
RSHN-2016L	16	14	0.10	35	0.3 to 30	0.3 to 30	350	
RSHN-2020L	20	14	0.10	22	0.4 to 30	0.4 to 30	350	
RSHN-2030L	30	14	0.10	12	0.6 to 30	0.6 to 30	350	

RSHN	-	2	006	L	D
Series Name		Rated Voltage 2 = 250Vac	Rated Current 003 = 3A 300 = 300A	Low Leakage Current 3A to 30A models	DIN Rail Mount 3A to 30A models

Related Products									
Type	Current Rating (A)	Series	Low Leakage	Faston on Terminals	Wire Leads	DIN Rail Mount	Fused	Discharge Resistor	Metal Case
Board mount line filter, HV Pulse	0.5 - 6	RSAG							
Board mount line filter	0.5 - 6	RSEG							
General purpose with faston terminals	6	RSEC							
General purpose	0.5 - 6	RSEL	Y	Y	Y				Y
HV pulse protection	0.5 - 6	RSAL	Y	Y	Y				
Power Entry Module with line filter	3, 6, 10	RPE	Y				Y	Y	
Power Entry Module with line filter, HV Pulse	3, 6, 10	RPA	Y					Y	
Compact size with screw terminals	6 - 30	RSEV				DIN-RSEV*			
Multipurpose	3 - 300	RSEN	Y (Up to 30A)			Y (Up to 30A)			
Multipurpose with HV pulse protection	3 - 60	RSAN	Y (Up to 30A)			Y (Up to 30A)			
High attenuation	3 - 300	RSHN	Y (Up to 30A)			Y (Up to 30A)			
High attenuation with pulse protection	3 - 300	RSMN	Y (Up to 30A)			Y (Up to 30A)			
Wide band, high attenuation	6 - 30	RSKN							

* Separate mounting bracket
[Click here for TDK-Lambda three phase filters.](#)

Specification		
Model		
Input		
Rated Voltage (max)	Vac/Vdc	250 (Safety certified for AC input only)
Input Frequency	Hz	47 - 63
Leakage Current (500Vac, 60Hz)	mA	See model selector
Safety Certifications and Markings	-	UL1283 (up to 60A), CSA C22.2 No.8 (Up to 30A), EN60939-1/-2 (ENEC14, up to 60A), conforms to RoHS Directive
Environmental		
Operating Temperature	°C	-25 to +85. See derating curves below
Storage Temperature	°C	-25 to +85
Humidity (non condensing)	%RH	Operating: 15 - 85, storage: 5 - 85
Cooling	-	Convection
Withstand Voltage	Vac	2,500 input to earth
Isolation Resistance (For 1 minute)	MΩ	>100 at 500Vdc
Vibration	-	10-55Hz Amplitude 1.5mm, Sweep for 1 min. X, Y and Z directions for 2 hours each
Other		
Weight (Typ)	-	See model selector
Size (LxWxH)	mm	See outline drawings
Size (LxWxH)	Inches	See outline drawings
Connectors	-	See outline drawings
MIL-HDBK-217F NOTICE2	Hours	RSHN-2003: 5,410,084, RSHN-2300: 3,790,176
Warranty	Years	5

Notes
 (1) [With inverse time circuit breaker. See UL report on website](#)
 See website for detailed specifications, test methods and installation manual
[RSHN technical files](#)

Mechanical Specification

Derating Curve

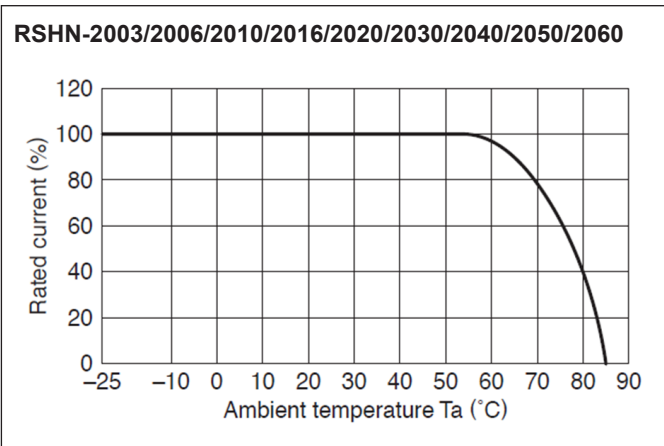

Derating Curve

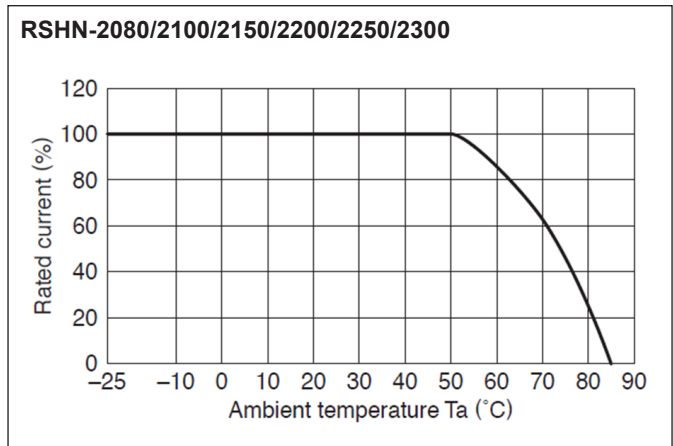

Schematic

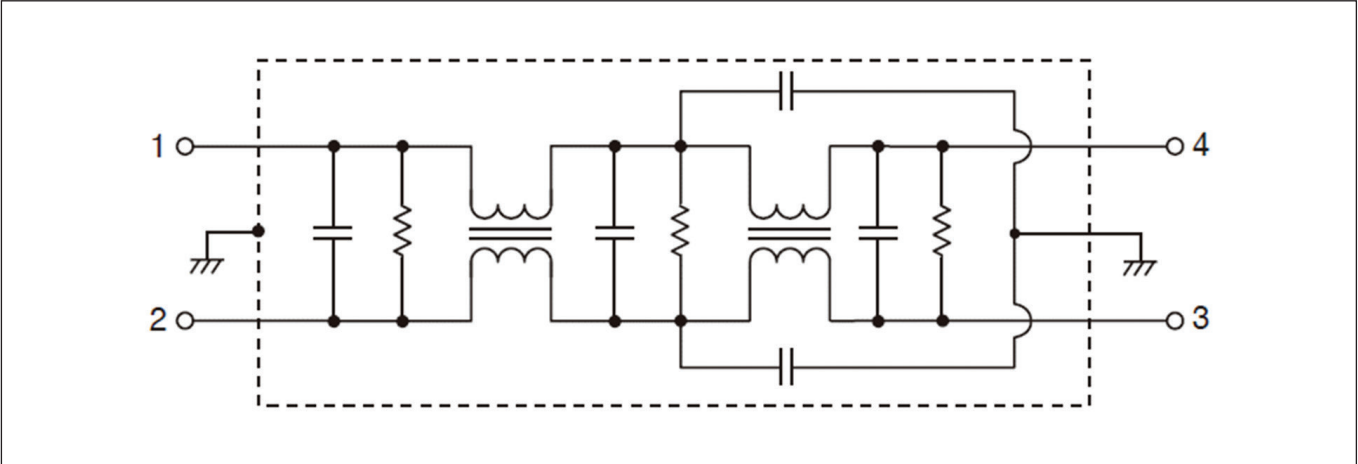

RSHN Outline Drawings

RSHN-2003/2006/2010/2016/2020/2030

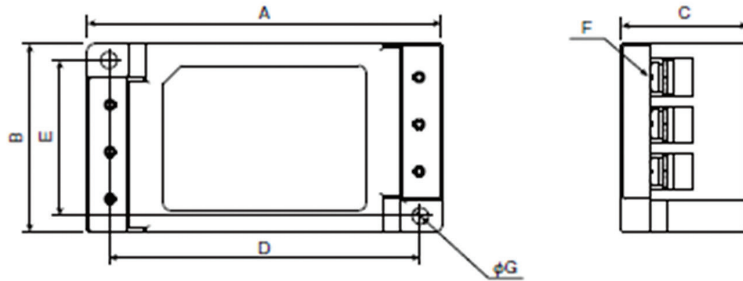

RSHN-2040/2050/2060/2080/2100/2150

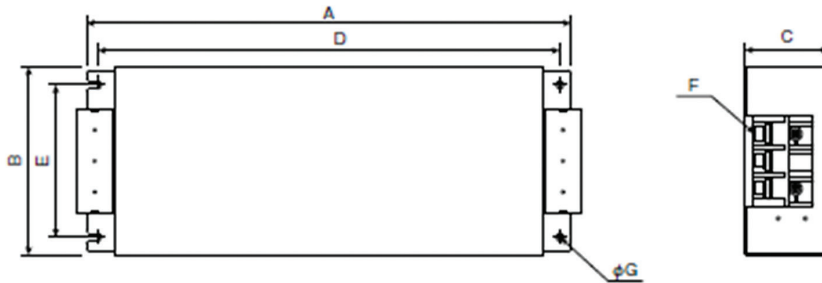

RSHN-2200/2250/2300

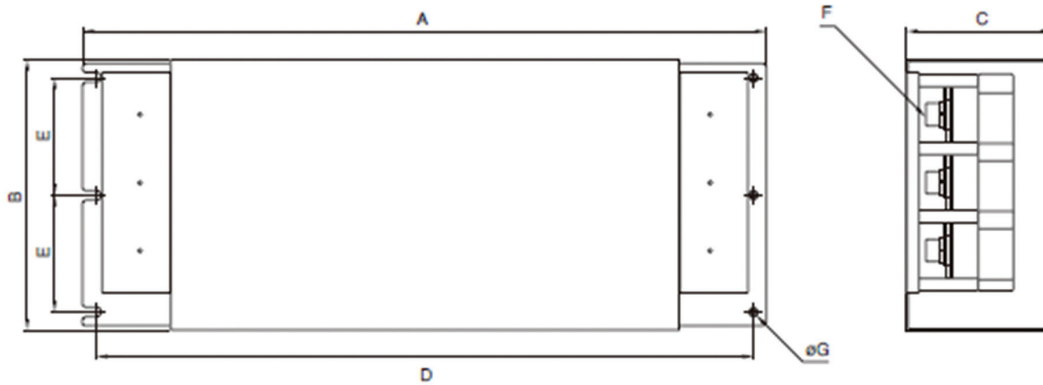

Dimensions in mm

Part No.	A	B	C	D	E	F	ϕG	Recommended clamping torque
RSHN-2003	98	52	35	86	43	M4	4.5	1.27N · m
RSHN-2006								
RSHN-2010								
RSHN-2016								
RSHN-2020								
RSHN-2030								
RSHN-2040	272	100	60	254	82	M5	5.5	2.5N · m
RSHN-2050								
RSHN-2060								
RSHN-2080	430	161	85	410	135	M8	8.5	7.64N · m
RSHN-2100								
RSHN-2150								
RSHN-2200	593	195	103	573	84.5	M10	8.5	11.8N · m
RSHN-2250								
RSHN-2300								

RSHN-5xxxD Outline Drawings

RSHN-2003D/2006D/2010D

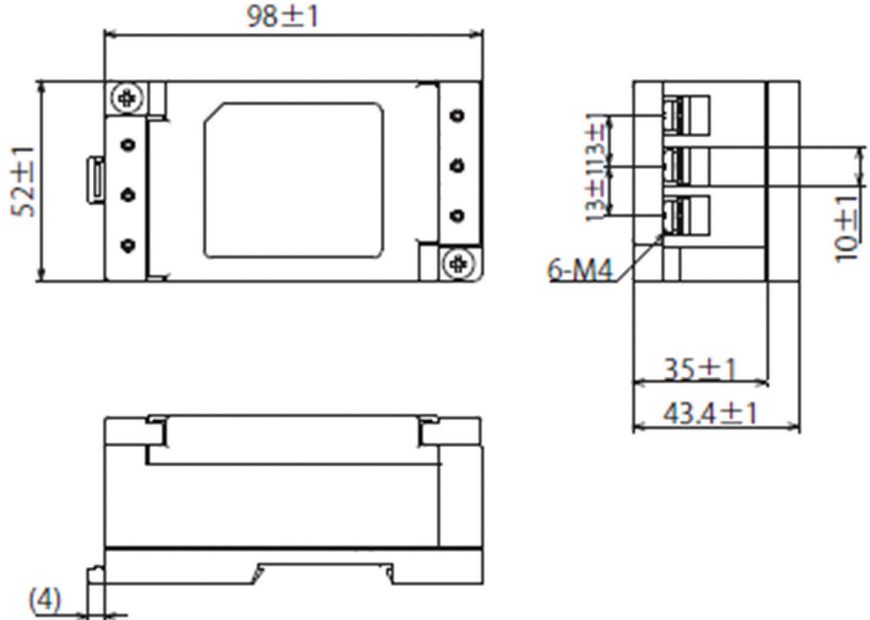

RSHN-2016D/2020D/2030D

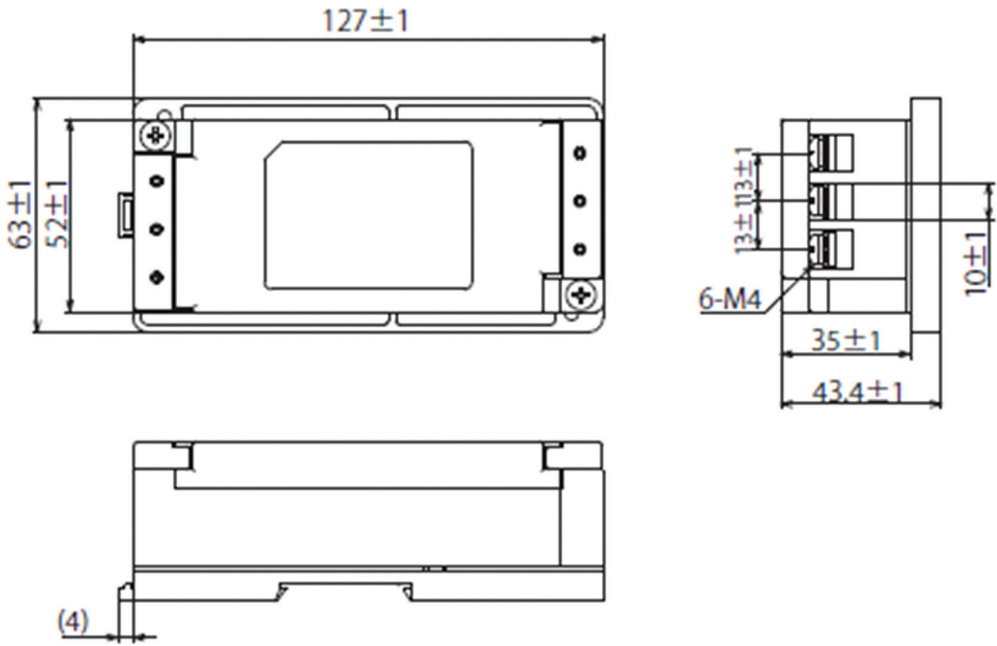

Dimensions in mm

RSHN Attenuation vs. Frequency

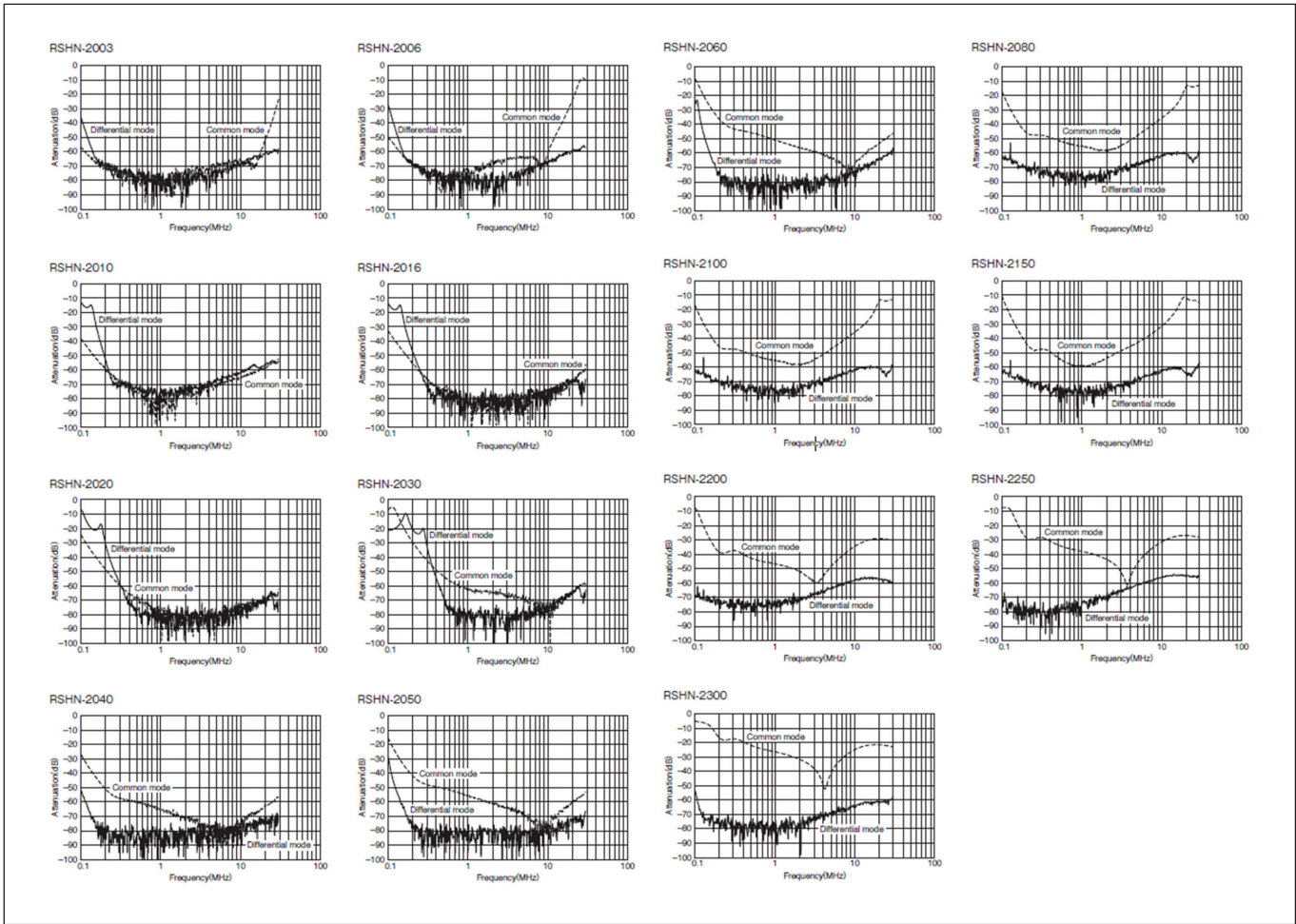

RSHN-20xxL Attenuation vs. Frequency

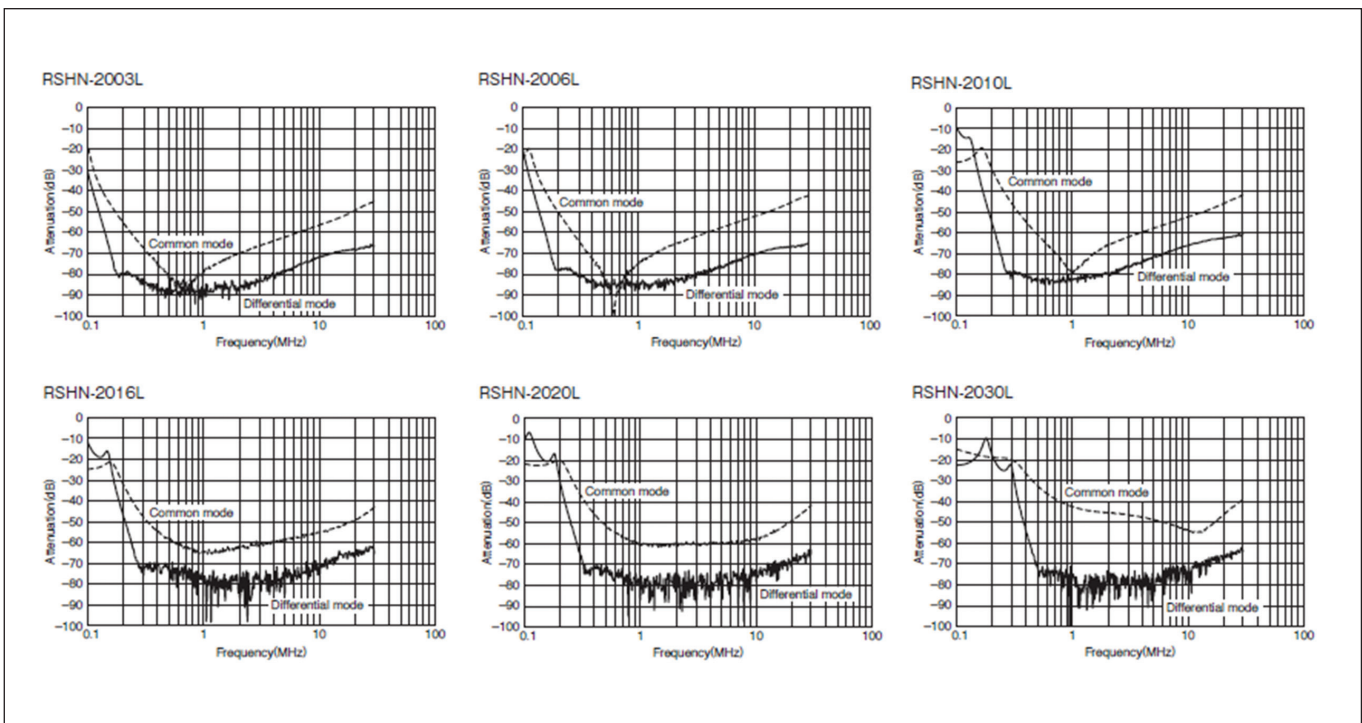



TDK-Lambda France SAS

Tel: +33 1 60 12 71 65
 tlf.fr-powersolutions@tdk.com
 www.emea.lambda.tdk.com/fr



Italy Sales Office

Tel: +39 02 61 29 38 63
 tlf.it-powersolutions@tdk.com
 www.emea.lambda.tdk.com/it



Netherlands

tlf.nl-powersolutions@tdk.com
 www.emea.lambda.tdk.com/nl



TDK-Lambda Germany GmbH

Tel: +49 7841 666 0
 tlq.powersolutions@tdk.com
 www.emea.lambda.tdk.com/de



Austria Sales Office

Tel: +43 2256 655 84
 tlq.at-powersolutions@tdk.com
 www.emea.lambda.tdk.com/at



Switzerland Sales Office

Tel: +41 44 850 53 53
 tlq.ch-powersolutions@tdk.com
 www.emea.lambda.tdk.com/ch



Nordic Sales Office

Tel: +45 8853 8086
 tlq.dk-powersolutions@tdk.com
 www.emea.lambda.tdk.com/dk



TDK-Lambda UK Ltd.

Tel: +44 (0) 12 71 85 66 66
 tlu.powersolutions@tdk.com
 www.emea.lambda.tdk.com/uk



TDK-Lambda Ltd.

Tel: +9 723 902 4333
 tli.powersolutions@tdk.com
 www.emea.lambda.tdk.com/il-en



TDK-Lambda Americas

Tel: +1 800-LAMBDA-4 or 1-800-526-2324
 tla.powersolutions@tdk.com
 www.us.lambda.tdk.com



TDK Electronics do Brasil Ltda

Tel: +55 11 3289-9599
 sales.br@tdk-electronics.tdk.com
 www.tdk-electronics.tdk.com/en



TDK-Lambda Corporation

Tel: +81-3-6778-1113
 www.jp.lambda.tdk.com



TDK-Lambda (China) Electronics Co. Ltd.

Tel: +86 21 6485-0777
 tlc.powersolutions@tdk.com
 www.lambda.tdk.com.cn



TDK-Lambda Singapore Pte Ltd.

Tel: +65 6251 7211
 tfs.marketing@tdk.com
 www.sg.lambda.tdk.com





TDK India Private Limited, Power Supply Division

Tel: +91 80 4039-0660
 mathew.philip@tdk.com
 www.sg.lambda.tdk.com



Looking for pricing, stock, or lifecycle information?

Click below to explore more details on WIN SOURCE:

-  [View RSHN-2010L on WIN SOURCE](#)
-  [TDK-Lambda Americas Inc. Information](#)

Optimize Your Supply Chain with WIN SOURCE Solutions

-  Global Sourcing Solution
-  Obsolete Management
-  Cost Control Management
-  Shortage Management
-  Alternative Solution
-  Excess Inventory Management