



Mach-NX Family

Data Sheet

FPGA-DS-02084-1.3

March 2022

Disclaimers

Lattice makes no warranty, representation, or guarantee regarding the accuracy of information contained in this document or the suitability of its products for any particular purpose. All information herein is provided AS IS, with all faults and associated risk the responsibility entirely of the Buyer. Buyer shall not rely on any data and performance specifications or parameters provided herein. Products sold by Lattice have been subject to limited testing and it is the Buyer's responsibility to independently determine the suitability of any products and to test and verify the same. No Lattice products should be used in conjunction with mission- or safety-critical or any other application in which the failure of Lattice's product could create a situation where personal injury, death, severe property or environmental damage may occur. The information provided in this document is proprietary to Lattice Semiconductor, and Lattice reserves the right to make any changes to the information in this document or to any products at any time without notice.

Contents

Acronyms in This Document	7
1. Introduction.....	8
1.1. Features.....	9
1.1.1. Solutions.....	9
1.1.2. Flexible Architecture.....	9
1.1.3. Cryptographic Secure Endave.....	9
1.1.4. Pre-Engineered Source Synchronous I/O.....	9
1.1.5. High Performance, Flexible I/O Buffer	9
1.1.6. Flexible On-Chip Clocking.....	9
1.1.7. Non-volatile, Reconfigurable	9
1.1.8. TransFR Reconfiguration	9
1.1.9. SoC Function Block.....	10
1.1.10. Applications.....	10
2. Architecture.....	12
2.1. Architecture Overview	12
2.2. PFU Blocks.....	13
2.2.1. Slices	13
2.2.2. Modes of Operation	15
2.2.3. RAM Mode	16
2.2.4. ROM Mode	16
2.3. Routing.....	16
2.4. Clock/Control Distribution Network	16
2.4.1. sysCLOCK Phase Locked Loops (PLLs).....	18
2.5. sysMEM Embedded Block RAM Memory	21
2.5.1. sysMEM Memory Block.....	21
2.5.2. Bus Size Matching.....	21
2.5.3. RAM Initialization and ROM Operation.....	21
2.5.4. Memory Cascading	21
2.5.5. Single, Dual, Pseudo-Dual Port and FIFO Modes.....	22
2.5.6. FIFO Configuration.....	23
2.5.7. Memory Core Reset.....	24
2.5.8. EBR Asynchronous Reset.....	24
2.6. Programmable I/O Cells (PIC)	26
2.7. PIO	27
2.7.1. Input Register Block.....	27
2.7.2. Output Register Block.....	27
2.7.3. Tri-state Register Block.....	28
2.8. Input Gearbox.....	29
2.9. Output Gearbox.....	31
2.10. sysI/O Buffer	33
2.10.1. Typical I/O Behavior during Power-up.....	33
2.10.2. Supported Standards.....	33
2.10.3. sysI/O Buffer Banks.....	35
2.11. Hot Socketing.....	36
2.12. On-chip Oscillator.....	36
2.13. Hardened SoC	36
2.13.1. Embedded Hardened IP Functions through SoC	36
2.13.2. Secure Enclave	37
2.14. User Flash Memory (UFM).....	38
2.15. Standby Mode and Power Saving Options	39
2.16. Power-On Reset.....	40
2.17. Configuration and Testing.....	40

2.17.1. IEEE 1149.1-Compliant Boundary Scan Testability	40
2.17.2. Device Configuration.....	40
2.18. TracelD.....	42
3. DC and Switching Characteristics	43
3.1. Absolute Maximum Rating	43
3.2. Recommended Operating Conditions	43
3.3. Power Supply Ramp Rates.....	44
3.4. Power-On Reset Voltage Levels	44
3.5. Hot Socketing Specifications	44
3.6. Programming/Erase Specifications.....	45
3.7. ESD Performance	45
3.8. DC Electrical Characteristics	45
3.9. Static Supply Current	46
3.10. Programming and Erase Supply Current.....	46
3.11. sys/O Recommended Operating Conditions.....	47
3.12. sys/O Single-Ended DC Electrical Characteristics.....	48
3.13. sys/O Differential Electrical Characteristics	49
3.13.1. LVDS.....	49
3.13.2. LVDS Emulation	49
3.13.3. LVDS25E DC Conditions	50
3.13.4. BLVDS	50
3.13.5. BLVDS DC Condition	50
3.13.6. LVPECL	51
3.13.7. LVPECL DC Conditions	51
3.13.8. MIPI D-PHY Emulation.....	52
3.14. Typical Building Block Function Performance.....	55
3.14.1. Pin-to-Pin Performance (LVCMOS25 12 mA Drive).....	55
3.14.2. Register-to-Register Performance.....	55
3.15. Derating Logic Timing	55
3.16. Maximum sys/O Buffer Performance.....	56
3.17. Mach-NX External Switching Characteristics – HC Devices.....	57
3.18. sysCLOCK PLL Timing.....	62
3.19. Flash Download Time.....	63
3.20. JTAG Port Timing Specifications.....	63
3.21. sysCONFIG Port Timing Specifications.....	65
3.22. I ² C Port Timing Specifications.....	65
3.23. SPI Port Timing Specifications	66
3.24. Switching Test Conditions	66
4. Signal Descriptions.....	67
4.1. Pin Information Summary	69
5. Ordering Information	70
5.1. Mach-NX Part Number Description	70
5.2. Ordering Information.....	70
5.3. Mach-NX Low Power Commercial and Industrial Grade Devices, Halogen Free (RoHS) Packaging	70
References	71
Revision History.....	72

Figures

Figure 2.1. Top View of the Mach-NX Device	12
Figure 2.2. PFU Block Diagram	13
Figure 2.3. Slice Diagram	14
Figure 2.4. Primary Clocks for Mach-NX Devices.....	17
Figure 2.5. Secondary High Fanout Nets for Mach-NX Devices.....	18
Figure 2.6. PLL Diagram	19
Figure 2.7. sysMEM Memory Primitives	22
Figure 2.8. Memory Core Reset	24
Figure 2.9. EBR Asynchronous Reset (Including GSR) Timing Diagram	24
Figure 2.10. Group of Four Programmable I/O Cells.....	26
Figure 2.11. Mach-NX Output Register Block Diagram	28
Figure 2.12. Input Gearbox	30
Figure 2.13. Output Gearbox	32
Figure 2.14. Mach-NX I/O Banks.....	35
Figure 2.15. Embedded Function Block Interface.....	36
Figure 2.16. Secure Enclave Core Block Diagram	37
Figure 3.1. LVDS Using External Resistors (LVDS25E).....	49
Figure 3.2. BLVDS Multi-point-Output Example.....	50
Figure 3.3. Differential LVPECL.....	51
Figure 3.4. MIPI D-PHY Input Using External Resistors	52
Figure 3.5. MIPI D-PHY Output Using External Resistors	53
Figure 3.6. Receiver GDDR71_RX. Waveforms	61
Figure 3.7. Transmitter GDDR71_TX. Waveforms	61
Figure 3.8. JTAG Port Timing Waveforms.....	64
Figure 3.9. Output Test Load, LVTTTL and LVCMOS Standards	66
Figure 5.1. Top Marking Diagram	70

Tables

Table 1.1. Mach-NX Family Selection Guide.....	11
Table 2.1. Resources and Modes Available per Slice	13
Table 2.2. Slice Signal Descriptions.....	15
Table 2.3. Number of Slices Required For Implementing Distributed RAM	16
Table 2.4. PLL Signal Descriptions.....	20
Table 2.5. sysMEM Block Configurations	21
Table 2.6. EBR Signal Descriptions.....	23
Table 2.7. Programmable FIFO Flag Ranges.....	23
Table 2.8. PIO Signal List.....	27
Table 2.9. Input Gearbox Signal List	29
Table 2.10. Output Gearbox Signal List	31
Table 2.11. Supported Input Standards	34
Table 2.12. Supported Output Standards.....	34
Table 2.13. Mach-NX UFM Size.....	38
Table 2.14. Mach-NX Power Saving Features Description.....	39
Table 3.1. Absolute Maximum Rating ^{1, 2, 3}	43
Table 3.2. Recommended Operating Conditions ¹	43
Table 3.3. Power Supply Ramp Rates	44
Table 3.4. Power-On Reset Voltage Levels.....	44
Table 3.5. Hot Socketing Specifications.....	44

Table 3.6. Programming/Erase Specifications.....	45
Table 3.7. DC Electrical Characteristics.....	45
Table 3.8. Static Supply Current ^{1, 2, 3, 6}	46
Table 3.9. Programming and Erase Supply Current ^{1, 2, 3, 4}	46
Table 3.10. sysI/O Recommended Operating Conditions.....	47
Table 3.11. sysI/O Single-Ended DC Electrical Characteristics ^{1, 2}	48
Table 3.12. LVDS.....	49
Table 3.13. LVDS25E DC Conditions.....	50
Table 3.14. BLVDS DC Conditions.....	50
Table 3.15. LVPECL DC Conditions.....	51
Table 3.16. MIPI DC Conditions.....	53
Table 3.17. MIPI D-PHY Output DC Conditions.....	54
Table 3.18. Pin-to-Pin Performance (LVCMOS25 12 mA Drive).....	55
Table 3.19. Register-to-Register Performance.....	55
Table 3.20. Maximum sysI/O Buffer Performance.....	56
Table 3.21. Mach-NX External Switching Characteristics – HC Devices ^{1, 2, 3, 4, 5, 6, 10}	57
Table 3.22. sysCLOCK PLL Timing.....	62
Table 3.23. Flash Download Time.....	63
Table 3.24. JTAG Port Timing Specifications.....	63
Table 3.25. sysCONFIG Port Timing Specifications.....	65
Table 3.26. I ² C Port Timing Specification.....	65
Table 3.27. SPI Port Timing Specifications.....	66
Table 3.28. Test Fixture Required Components, Non-Terminated Interfaces.....	66
Table 4.1. Signal Descriptions.....	67
Table 4.2. LFMNX-50.....	69

Acronyms in This Document

A list of acronyms used in this document.

Acronym	Definition
AES	Advanced Encryption Standard
BGA	Ball Grid Array
BLVDS	Bidirectional Low Voltage Differential Signaling
CMOS	Complementary Metal Oxide Semiconductor
EBR	Embedded Block RAM
ECDSA	Elliptic Curve Digital Signature Algorithm
ECDH	Elliptic Curve Diffie-Hellman
ECIES	Elliptic Curve Integrated Encryption Scheme
ECLK	Edge Clock
FIPS	Federal Information Processing Standard
HMAC	Hash Message Authentication Code
HSP	High Speed Port
I ² C	Inter-Integrated Circuit
I ³ C	Improved Inter-Integrated Circuit
IP	Intellectual Property
JTAG	Joint Test Action Group
LC	Logic Cell
LED	Light-emitting Diode
LUT	Look Up Table
LVC MOS	Low Voltage CMOS
LVDS	Low Voltage Differential Signaling
LVPECL	Low Voltage Positive Emitter Coupled Logic
LVTTL	Low Voltage Transistor-Transistor Logic
MIPI	Mobile Industry Processor Interface
MLVDS	Multipoint Low-Voltage Differential Signaling
MES	Manufacture Electronic Signature
OTP	One Time Programmable
PCLK	Primary Clock
PFU	Programmable Functional Unit
PLL	Phase Locked Loop
POR	Power-On Reset
RAM	Random Access Memory
SHA	Secure Hash Algorithm
SoC	System on Chip
SPI	Serial Peripheral Interface
TransFR	Transparent Field Reconfiguration
TRNG	True Random Number Generator
TTL	Transistor-Transistor Logic
UFM	User Flash Memory

1. Introduction

The Mach™-NX device family is the next generation of Lattice Semiconductor Low Density FPGAs including enhanced security features and on-chip dual boot flash comprised of SoC and FPGA partitions. The enhanced security features include Advanced Encryption Standard (AES) AES-128/256, Secure Hash Algorithm (SHA) SHA-256/384, Elliptic Curve Digital Signature Algorithm (ECDSA), Elliptic Curve Integrated Encryption Scheme (ECIES), Hash Message Authentication Code (HMAC) HMAC-SHA256/384, Public Key Cryptography, and Unique Secure ID. The Mach-NX family is a Root of Trust hardware solution that can easily scale to protect the whole system with its enhanced bitstream security and user mode functions. Mach-NX device supports the latest industry standard I/O and provides breakthrough I/O density with high number of options for I/O programmability.

The Mach-NX family of devices are low power, instant-on, Flash based FPGAs with user density of 8400 Logic Cells (LCs). Mach-NX devices include on-chip dual boot configuration flash for FPGA as well as multi-sectored User Flash Memory (UFM). In addition to LC-based programmable logic, these devices feature Embedded Block RAM (EBR), Distributed RAM, Phase Locked Loops (PLLs), pre-engineered source synchronous I/O support, advanced configuration support including on-chip dual-boot capability and hardened versions of commonly used functions such as SPI controller, I²C controller, and timer/counter.

The Mach-NX FPGA is available in an advanced halogen-free package of 19 x 19 mm fcBGA and 14 x 14 mm fcCSP in –5 speed grade. This device has an internal linear voltage regulator, which supports external VCC supply voltages of 3.3 V or 2.5 V. [Table 1.1](#) shows the LC density, package and I/O options, along with other key parameters.

The Mach-NX device offers enhanced I/O features such as drive strength control, finer slew rate control, bus-keeper latches, pull-up resistors, pull-down resistors, open drain outputs, and hot socketing. Pull-up, pull-down, and bus-keeper features are controllable on a *per-pin* basis.

A user-programmable internal oscillator is included in Mach-NX devices. The clock output from this oscillator may be divided by the timer or counter for use as clock input in functions such as LED control, key-board scanner, and similar state machines.

The Mach-NX devices also provide flexible, reliable, and secure configuration from on-chip Flash with the encryption and authentication options. These devices can be configured by an external master through the JTAG test access port or through the SPI/I²C port. Additionally, Mach-NX devices support on-chip dual-boot capability for the FPGA to reduce the system cost.

Lattice Semiconductor provides a variety of design tools that allow complex designs to be efficiently implemented using the Mach-NX family of devices. Popular logic synthesis tools provide synthesis library support for Mach-NX devices. Lattice design tools use the synthesis tool output along with the user-specified preferences and constraints to place and route the design in the Mach-NX device. These tools extract the timing from the routing and back-annotate it into the design for timing verification.

Lattice Semiconductor provides many pre-engineered Intellectual Property (IP) LatticeCORE™ modules, including a number of reference designs licensed free of charge, optimized for the Mach-NX FPGA family. By using these configurable soft core IP cores as standardized blocks, you are free to concentrate on the unique aspects of their design, increasing their productivity.

1.1. Features

1.1.1. Solutions

- Best-In-Class control FPGA with advanced security functions, provide secure/authenticated boot and Root of Trust function
- Optimized footprint, logic density, I/O count, I/O performance devices for I/O management and logic applications
- High I/O logic, high I/O devices for I/O expansion applications

1.1.2. Flexible Architecture

- High I/O to LC ratio with up to 378 I/O pins

1.1.3. Cryptographic Secure Enclave

- Advanced Encryption Standard (AES): AES-128/256 Encryption/Decryption
- Secure Hash Algorithm (SHA): SHA-256/384
- Elliptic Curve Digital Signature Algorithm (ECDSA): ECDSA-based authentication
- Hash Message Authentication Code (HMAC): HMAC-SHA256
- Elliptic Curve Integrated Encryption Scheme (ECIES): ECIES Encryption and Decryption
- True Random Number Generator (TRNG)
- Key Management using Elliptic Curve Diffie-Hellman (ECDH) Public Key Cryptography
- Unique Secure ID
- Guard against malicious attacks
- Mailbox Interface to SoC Function Block
- Federal Information Processing Standard (FIPS) supported Security Protocols

1.1.4. Pre-Engineered Source Synchronous I/O

- DDR registers in I/O cells
- Dedicated gearing logic
- Generic DDR, DDRx2, DDRx4

1.1.5. High Performance, Flexible I/O Buffer

- Programmable sysI/O™ buffer supports wide range of interfaces on select banks:
 - LVCMOS 3.3/2.5/1.8/1.5/1.2
 - LVTTTL
 - LVDS, Bus-LVDS, MLVDS, LVPECL
 - Schmitt trigger inputs, up to 0.5 V hysteresis
- Ideal for I/O bridging applications
- Slew rate control Slow/Fast
- I/O support hot socketing
- On-chip differential termination
- Programmable pull-up or pull-down mode

1.1.6. Flexible On-Chip Clocking

- Five primary clock inputs
- Eight internal primary clock lines
- On-chip oscillator with 5.5% accuracy
- Two analog PLLs per device with fractional-n frequency synthesis
 - Wide input frequency range (7 MHz to 400 MHz).
- IEEE Standard 1149.1 boundary scan
- IEEE 1532 compliant in-system programming

1.1.7. Non-volatile, Reconfigurable

- Instant-on
- Multi-sectored UFM for customer data storage
- Single-chip, secure solution
- Programmable through JTAG, SPI or I2C
- Reconfigurable Flash
 - Supports background programming of non-volatile memory

1.1.8. TransFR Reconfiguration

- In-field logic update while I/O holds the system state on select banks

1.1.9. SoC Function Block

- 32-bit RISC-V processor with on-chip firmware RAM and AHB-Lite master interface
- Cryptographic Secure Enclave
- On-chip hardened functions: SPI, I2C, timer/counter, and PFR

1.1.10. Applications

- Secure boot and Root of Trust
- Compute and Storage
- Wireless Communications
- Industrial Control Systems

Table 1.1. Mach-NX Family Selection Guide

Features		LFMNX-50
User Logic Cell (LC)		8400
Distributed RAM (kbits)		73
EBR SRAM (kbits)		432
UFM (kbits)		1064/2669 ¹
Number of PLLs		2
Hardened Security Functions ²	Configurable PFR	1
	Secure Enclave	1
SoC Hardened Functions	I ² C	2
	SPI	1
	Timer/Counter	1
	Oscillator	1
On-chip Dual-boot		Yes ³
MIPI D-PHY Support		Yes
Core Vcc	2.5 – 3.3V	Yes
Temperature	Commercial	Yes
	Industrial	Yes

Packages	I/O
256-ball fcCSP (14 mm × 14 mm, 0.8 mm)	188
484-ball fcBGA (19 mm × 19 mm, 0.8 mm)	378

Notes:

1. When dual-boot is disabled, image space can be repurposed as extra UFM. Refer to [Table 2.13](#) for more details.
2. 40K LC equivalent design.
3. For user logic only.

2. Architecture

2.1. Architecture Overview

The Mach-NX family architecture contains an array of logic blocks surrounded by Programmable I/O (PIO). All logic density devices in this family have sysCLOCK™ PLLs and blocks of sysMEM Embedded Block RAM (EBRs).

Figure 2.1 shows the block diagrams of the various family members.

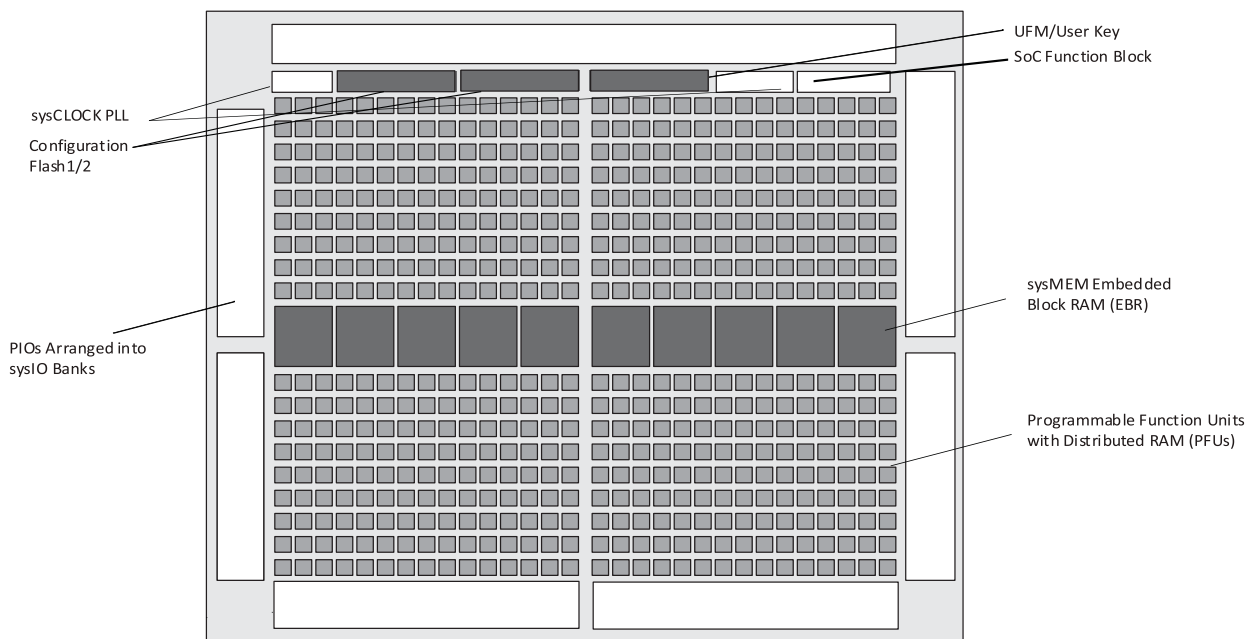

Figure 2.1. Top View of the Mach-NX Device

The logic blocks, Programmable Functional Unit (PFU) and sysMEM EBR blocks, are arranged in a two-dimensional grid with rows and columns. Each row has either the logic blocks or the EBR blocks. The PIO cells are located at the periphery of the device, arranged in banks. The PFU contains the building blocks for logic, arithmetic, RAM, ROM, and register functions. The PIOs utilize a flexible I/O buffer referred to as a sysI/O buffer that supports operation with a variety of interface standards. The blocks are connected with many vertical and horizontal routing channel resources. The place and route software tool automatically allocates these routing resources.

In the Mach-NX family, there are different types of I/O buffers on the different banks. Refer to the details in later sections of this document. The sysMEM EBRs are large, dedicated fast memory blocks. These blocks can be configured as RAM, ROM or FIFO. FIFO support includes dedicated FIFO pointer and flag “hard” control logic to minimize LC usage.

The Mach-NX registers in PFU and sysI/O can be configured to be SET or RESET. After power up and device is configured, the device enters into user mode with these registers SET/RESET according to the configuration setting, allowing device entering to a known state for predictable system function.

The Mach-NX architecture also provides up to two sysCLOCK Phase Locked Loop (PLL) blocks. These blocks are located at the ends of the on-chip Flash block. The PLLs have multiply, divide, and phase shifting capabilities that are used to manage the frequency and phase relationships of the clocks.

Mach-NX devices provide commonly used hardened functions such as SPI controller, I²C controller, timer/counter, and Secure Enclave through SoC. The hardened functions are accessed via a slave AHB-Lite port interface mastered by the SoC.

Secure Enclave integrates multiple security blocks used for authenticated boot function of the Mach-NX device. User IP located in the fabric can also use these hardened blocks for implementing system level security functions.

Mach-NX devices also provide multiple blocks of User Flash Memory (UFM). FPGA logic can access the UFM via a slave AHB-Lite port interface mastered by the SoC. The UFM space also provides the User Key storage for customer security functions. The UFM can be accessed through the SPI, I²C, and JTAG ports.

Every device in the family has a JTAG port that supports programming and configuration of the device as well as access to the user logic. The Mach-NX devices are available for operation from 3.3 V and 2.5 V power supplies, providing easy integration into the overall system.

2.2. PFU Blocks

The core of the Mach-NX device consists of PFU blocks, which can be programmed to perform logic, arithmetic, distributed RAM and distributed ROM functions. Each PFU block consists of four interconnected slices numbered 0 to 3 as shown in Figure 2.2. Each slice contains two LUTs and two registers. There are 53 inputs and 25 outputs associated with each PFU block.

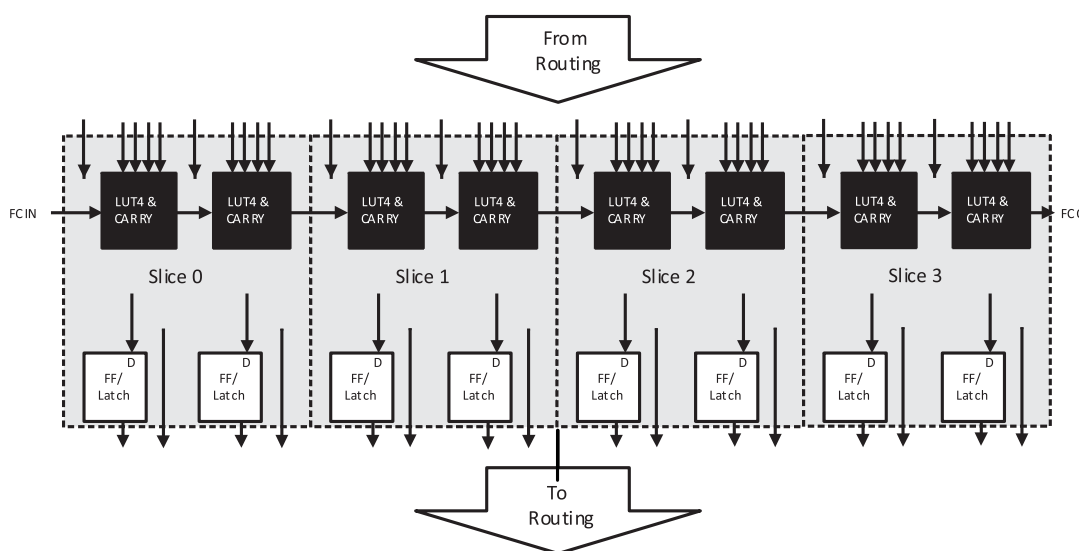

Figure 2.2. PFU Block Diagram

2.2.1. Slices

Slices 0-3 contain two LUT4s feeding two registers. Slices 0-2 can be configured as distributed memory. Table 2.1 shows the capability of the slices in PFU blocks along with the operation modes they support. In addition, each PFU contains logic that allows the LUTs to be combined to perform functions such as LUT5, LUT6, LUT7 and LUT8. The control logic performs set/reset functions (programmable as synchronous/asynchronous), clock select, chip-select and wider RAM/ROM functions.

Table 2.1. Resources and Modes Available per Slice

Slice	PFU Block	
	Resources	Modes
Slice 0	2 LUT4s and 2 Registers	Logic, Ripple, RAM, ROM
Slice 1	2 LUT4s and 2 Registers	Logic, Ripple, RAM, ROM
Slice 2	2 LUT4s and 2 Registers	Logic, Ripple, RAM, ROM
Slice 3	2 LUT4s and 2 Registers	Logic, Ripple, ROM

Figure 2.3 shows an overview of the internal logic of the slice. The registers in the slice can be configured for positive/negative and edge triggered or level sensitive clocks. All slices have 15 inputs from routing and one from the carry-chain (from the adjacent slice or PFU). There are seven outputs: six for routing and one to carry-chain (to the adjacent PFU). Table 2.2 lists the signals associated with Slices 0-3.

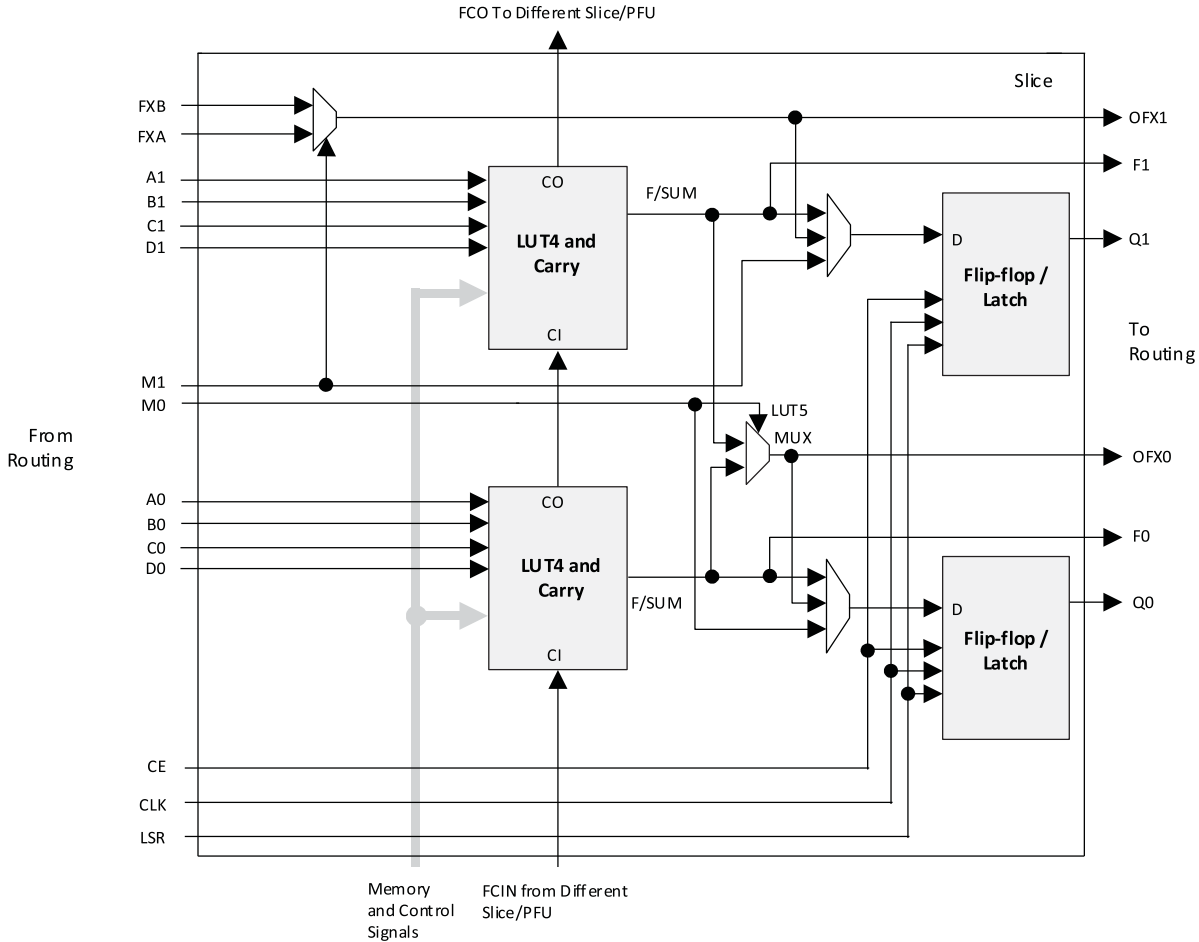

For Slices 0 and 1, memory control signals are generated from Slice 2 as follows:

- WCK is CLK
- WRE is from LSR
- DI[3:2] for Slice 1 and DI[1:0] for Slice 0 data from Slice 2
- WAD [A:D] is a 4-bit address from slice 2 LUT input

Figure 2.3. Slice Diagram

Table 2.2. Slice Signal Descriptions

Function	Type	Signal Names	Description
Input	Data signal	A0, B0, C0, D0	Inputs to LUT4
Input	Data signal	A1, B1, C1, D1	Inputs to LUT4
Input	Multi-purpose	M0/M1	Multi-purpose input
Input	Control signal	CE	Clock enable
Input	Control signal	LSR	Local set/reset
Input	Control signal	CLK	System clock
Input	Inter-PFU signal	FCIN	Fast carry in ¹
Output	Data signals	F0, F1	LUT4 output register bypass signals
Output	Data signals	Q0, Q1	Register outputs
Output	Data signals	OFX0	Output of a LUT5 MUX
Output	Data signals	OFX1	Output of a LUT6, LUT7, LUT8 ² MUX depending on the slice
Output	Inter-PFU signal	FCO	Fast carry out ¹

Notes:

1. See [Figure 2.2](#) for connection details.
2. Requires two PFUs.

2.2.2. Modes of Operation

Each slice has up to four potential modes of operation: Logic, Ripple, RAM and ROM.

2.2.2.1. Logic Mode

In this mode, the LUTs in each slice are configured as 4-input combinatorial lookup tables. A LUT4 can have 16 possible input combinations. Any four input logic functions can be generated by programming this lookup table. Since there are two LUT4s per slice, a LUT5 can be constructed within one slice. Larger look-up tables such as LUT6, LUT7, and LUT8 can be constructed by concatenating other slices. Note LUT8 requires more than four slices.

2.2.2.2. Ripple Mode

Ripple mode supports the efficient implementation of small arithmetic functions. In Ripple mode, the following functions can be implemented by each slice:

- Addition 2-bit
- Subtraction 2-bit
- Add/subtract 2-bit using dynamic control
- Up counter 2-bit
- Down counter 2-bit
- Up/down counter with asynchronous clear
- Up/down counter with preload (sync)
- Ripple mode multiplier building block Multiplier support
- Comparator functions of A and B inputs
 - A greater-than-or-equal-to B
 - A not-equal-to B
 - A less-than-or-equal-to B

Ripple mode includes an optional configuration that performs arithmetic using fast carry chain methods. In this configuration (also referred to as CCU2 mode), two additional signals, Carry Generate and Carry Propagate, are generated on a per-slice basis to allow fast arithmetic functions to be constructed by concatenating slices.

2.2.3. RAM Mode

In this mode, a 16x4-bit distributed single port RAM (SPR) can be constructed by using each LUT block in Slice 0 and Slice 1 as a 16x1-bit memory. Slice 2 is used to provide memory address and control signals.

Mach-NX devices support distributed memory initialization.

The Lattice design tools support the creation of a variety of different size memories. Where appropriate, the software constructs these using distributed memory primitives that represent the capabilities of the PFU. [Table 2.3](#) shows the number of slices required to implement different distributed RAM primitives.

Table 2.3. Number of Slices Required For Implementing Distributed RAM

	SPR 16 x 4	PDPR 16 x 4
Number of slices	3	3

Note: SPR = Single Port RAM, PDPR = Pseudo Dual Port RAM

2.2.4. ROM Mode

ROM mode uses the LUT logic; hence, slices 0-3 can be used in ROM mode. Preloading is accomplished through the programming interface during PFU configuration.

2.3. Routing

There are many resources provided in the Mach-NX devices to route signals individually or as buses with related control signals. The routing resources consist of switching circuitry, buffers and metal interconnect (routing) segments.

The inter-PFU connections are made with three different types of routing resources: x1 (spans two PFUs), x2 (spans three PFUs) and x6 (spans seven PFUs). The x1, x2, and x6 connections provide fast and efficient connections in the horizontal and vertical directions.

The design tools take the output of the synthesis tool and places and routes the design. The place and route tool is completely automatic, although an interactive routing editor is available.

2.4. Clock/Control Distribution Network

Each Mach-NX device has clock inputs (PCLK [T, C] [Banknum]_[2..0]) – from Bank 0 to Bank 2. These clock inputs drive the clock nets. These five inputs can be differential or single-ended and may be used as general purpose I/O if they are not used to drive the clock nets. When using a single ended clock input, only the PCLKT input can drive the clock tree directly.

The Mach-NX architecture has three types of clocking resources: edge clocks, primary clocks, and secondary high fanout nets. Mach-NX devices have two edge clocks each along Bank 0 and Bank 2 edges. Edge clocks are used to clock I/O registers and have low injection time and skew. Edge clock inputs are from PLL outputs, primary clock pads, edge clock bridge outputs and user logic sources.

The eight primary clock lines in the primary clock network drive throughout the entire device and can provide clocks for all resources within the device including PFUs, EBRs and PICs. In addition to the primary clock signals, Mach-NX devices also have eight secondary high fanout signals, which can be used for global control signals, such as clock enables, synchronous or asynchronous clears, presets, output enables, and others. Internal logic can drive the global clock network for internally-generated global clocks and control signals.

The maximum frequency for the primary clock network is shown in the [Mach-NX External Switching Characteristics – HC Devices](#) table.

Primary clock signals for the Mach-NX devices are generated from eight 27:1 muxes. The available clock sources include five I/O sources, 11 routing inputs, eight clock divider inputs and up to eight sysCLOCK PLL outputs.

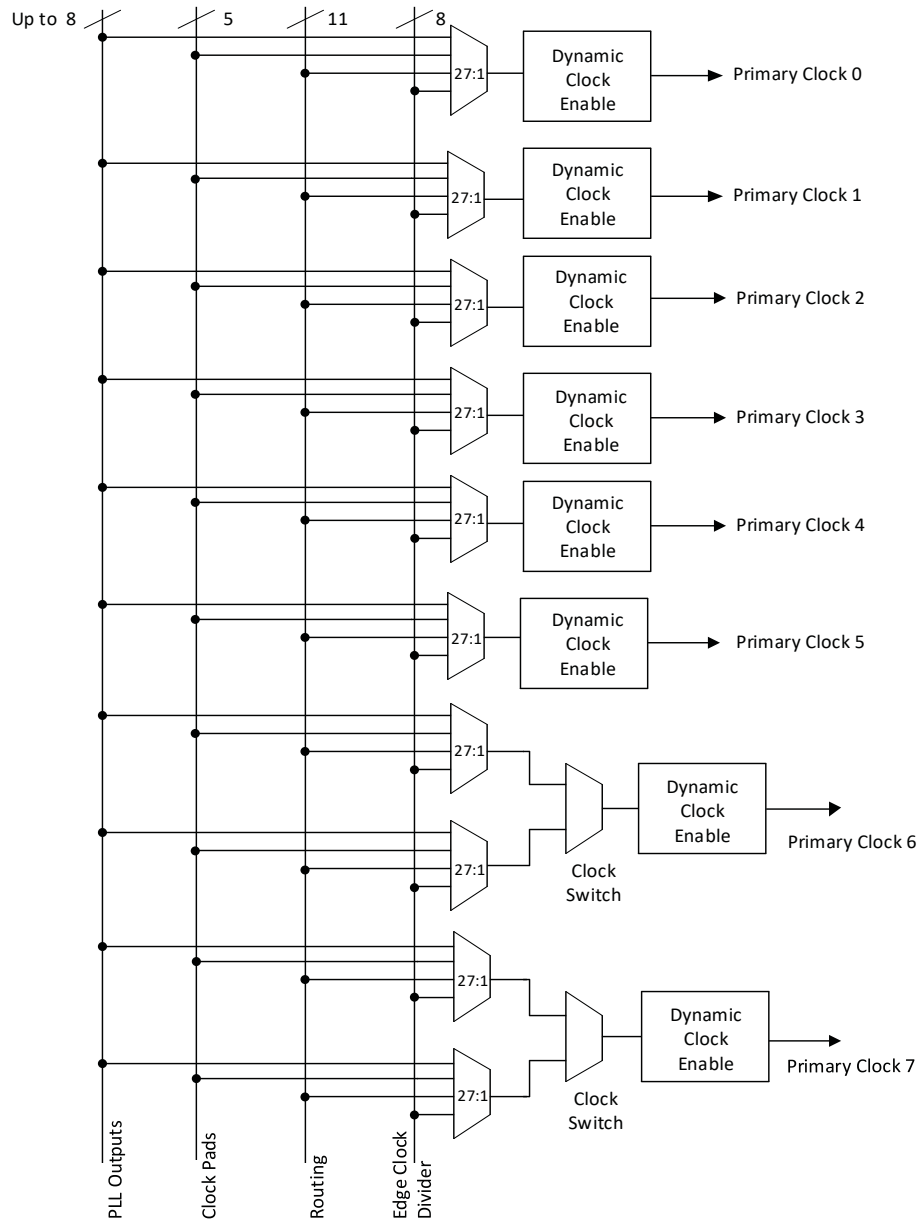

Figure 2.4. Primary Clocks for Mach-NX Devices

Eight secondary high fanout nets are generated from eight 8:1 muxes as shown in [Figure 2.5](#). One of the eight inputs to the secondary high fanout net input mux comes from dual function clock pins and the remaining seven come from internal routing. The maximum frequency for the secondary clock network is shown in the [Mach-NX External Switching Characteristics – HC Devices](#) table.

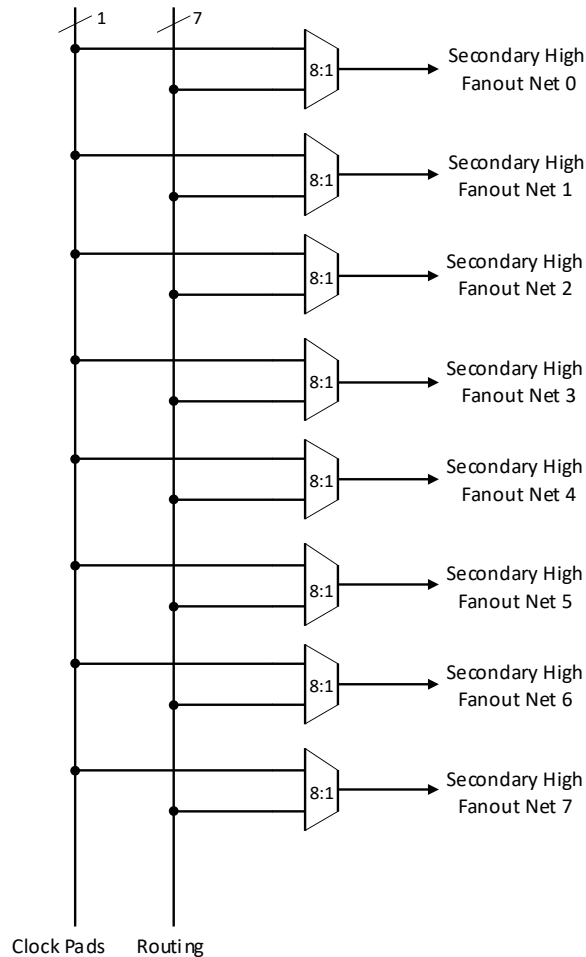

Figure 2.5. Secondary High Fanout Nets for Mach-NX Devices

2.4.1. sysCLOCK Phase Locked Loops (PLLs)

The sysCLOCK PLLs provide the ability to synthesize clock frequencies. All Mach-NX devices have one or more sysCLOCK PLL. CLKI is the reference frequency input to the PLL and its source can come from an external I/O pin or from internal routing. CLKFB is the feedback signal to the PLL, which can come from internal routing or an external I/O pin. The feedback divider is used to multiply the reference frequency and thus synthesize a higher frequency clock output.

The Mach-NX sysCLOCK PLLs support high resolution (16-bit) fractional-N synthesis. Fractional-N frequency synthesis allows you to generate an output clock, which is a non-integer multiple of the input frequency.

Each output has its own output divider, thus allowing the PLL to generate different frequencies for each output. The output dividers can have a value from 1 to 128. The output dividers may also be cascaded together to generate low frequency clocks. The CLKOP, CLKOS, CLKOS2, and CLKOS3 outputs can all be used to drive the Mach-NX clock distribution network directly or general purpose routing resources can be used.

The LOCK signal is asserted when the PLL determines it has achieved lock and deasserted if a loss of lock is detected. A block diagram of the PLL is shown in [Figure 2.6](#).

The setup and hold times of the device can be improved by programming a phase shift into the CLKOS, CLKOS2, and CLKOS3 output clock, which advance or delay the output clock with reference to the CLKOP output clock.

This phase shift can be either programmed during configuration or can be adjusted dynamically. In dynamic mode, the PLL may lose lock after a phase adjustment on the output used as the feedback source and not relock until the t_{LOCK} parameter has been satisfied.

The Mach-NX device also has a feature that allows you to select between two different reference clock sources dynamically. This feature is implemented using the PLLREFCS primitive. The timing parameters for the PLL are shown in the [sysCLOCK PLL Timing](#) table.

The Mach-NX PLL contains an AHB-Lite slave port feature that allows the PLL settings, including divider values, to be dynamically changed from the SoC. When using this feature the SoC block must also be instantiated in the design to allow access through the AHB-Lite port. Similar to the dynamic phase adjustment, when PLL settings are updated through the AHB-Lite port, the PLL may lose lock and not relock until the t_{LOCK} parameter has been satisfied. The timing parameters for the PLL are shown in the [sysCLOCK PLL Timing](#) table.

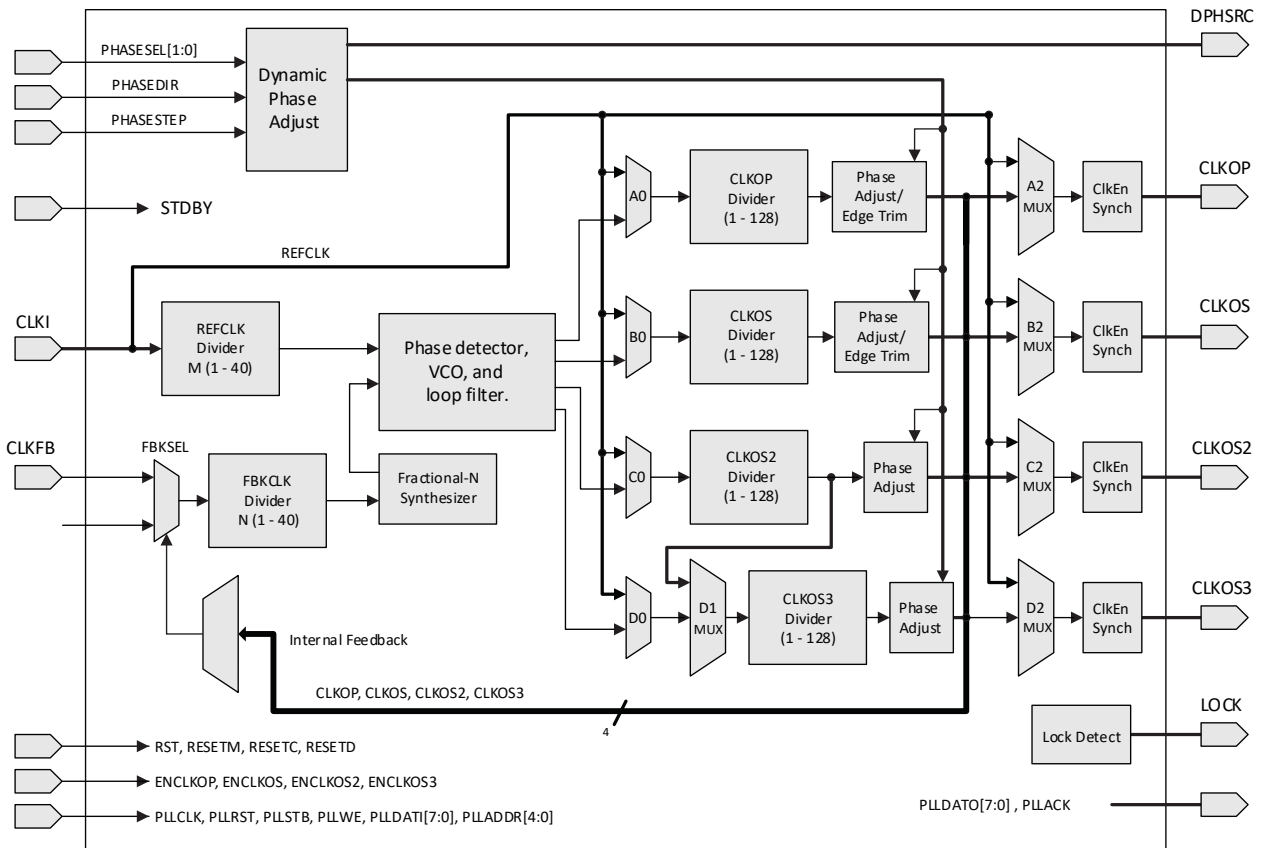

Figure 2.6. PLL Diagram

Table 2.4 provides signal descriptions of the PLL block.

Table 2.4. PLL Signal Descriptions

Port Name	I/O	Description
CLKI	I	Input clock to PLL
CLKFB	I	Feedback clock
PHASESEL[1:0]	I	Select which output is affected by Dynamic Phase adjustment ports
PHASEDIR	I	Dynamic Phase adjustment direction
PHASESTEP	I	Dynamic Phase step – toggle shifts VCO phase adjust by one step.
CLKOP	O	Primary PLL output clock (with phase shift adjustment)
CLKOS	O	Secondary PLL output clock (with phase shift adjust)
CLKOS2	O	Secondary PLL output clock2 (with phase shift adjust)
CLKOS3	O	Secondary PLL output clock3 (with phase shift adjust)
LOCK	O	PLL LOCK, asynchronous signal. Active high indicates PLL is locked to input and feedback signals.
DPHSRC	O	Dynamic Phase source – ports or AHB-Lite
STDBY	I	Standby signal to power down the PLL
RST	I	PLL reset without resetting the M-divider. Active high reset.
RESETM	I	PLL reset – includes resetting the M-divider. Active high reset.
RESETC	I	Reset for CLKOS2 output divider only. Active high reset.
RESETD	I	Reset for CLKOS3 output divider only. Active high reset.
ENCLKOP	I	Enable PLL output CLKOP
ENCLKOS	I	Enable PLL output CLKOS when port is active
ENCLKOS2	I	Enable PLL output CLKOS2 when port is active
ENCLKOS3	I	Enable PLL output CLKOS3 when port is active
PLLCLK	I	PLL data bus clock input signal
PLLSTB	I	PLL data bus reset. This resets only the data bus not any register values.
PLLWE	I	PLL data bus write enable signal
PLLADDR [4:0]	I	PLL data bus address
PLLDATI [7:0]	I	PLL data bus data input
PLLDATO [7:0]	O	PLL data bus data output
PLLACK	O	PLL data bus acknowledge signal

2.5. sysMEM Embedded Block RAM Memory

The Mach-NX devices contain sysMEM Embedded Block RAMs (EBRs). The EBR consists of a 9 kb RAM, with dedicated input and output registers. This memory can be used for a wide variety of purposes including data buffering, PROM for the soft processor and FIFO.

2.5.1. sysMEM Memory Block

The sysMEM block can implement single port, dual port, pseudo dual port, or FIFO memories. Each block can be used in a variety of depths and widths as shown in [Table 2.5](#).

Table 2.5. sysMEM Block Configurations

Memory Mode	Configurations
Single Port	8,192 x 1
	4,096 x 2
	2,048 x 4
	1,024 x 9
True Dual Port	8,192 x 1
	4,096 x 2
	2,048 x 4
	1,024 x 9
Pseudo Dual Port	8,192 x 1
	4,096 x 2
	2,048 x 4
	1,024 x 9
FIFO	512 x 18
	8,192 x 1
	4,096 x 2
	2,048 x 4
	1,024 x 9
	512 x 18

2.5.2. Bus Size Matching

All of the multi-port memory modes support different widths on each of the ports. The RAM bits are mapped LSB word 0 to MSB word 0, LSB word 1 to MSB word 1, and so on. Although the word size and number of words for each port varies, this mapping scheme applies to each port.

2.5.3. RAM Initialization and ROM Operation

If desired, the contents of the RAM can be preloaded during device configuration. EBR initialization data can be loaded from the Configuration Flash.

Mach-NX EBR initialization data can also be loaded from the UFM. To maximize the number of UFM bits, initialize the EBRs used in your design to an all-zero pattern. Initializing to an all-zero pattern does not use up UFM bits. Mach-NX devices are designed such that multiple EBRs share the same initialization memory space if they are initialized to the same pattern.

By preloading the RAM block during the chip configuration cycle and disabling the write controls, the sysMEM block can also be utilized as a ROM.

2.5.4. Memory Cascading

Larger and deeper blocks of RAM can be created using EBR sysMEM Blocks. Typically, the Lattice design tools cascade memory transparently, based on specific design inputs.

2.5.5. Single, Dual, Pseudo-Dual Port and FIFO Modes

Figure 2.7 shows the five basic memory configurations and their input/output names. In all the sysMEM RAM modes, the input data and addresses for the ports are registered at the input of the memory array. The output data of the memory is optionally registered at the memory array output.

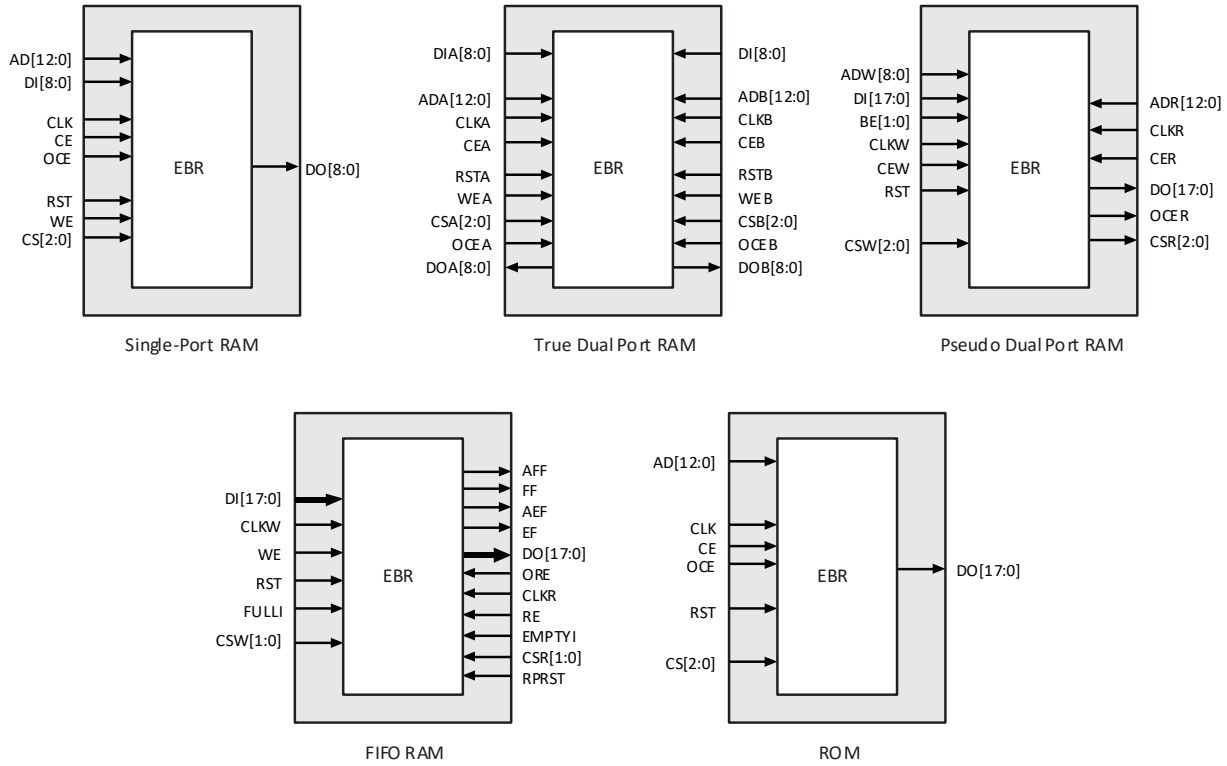

Figure 2.7. sysMEM Memory Primitives

Table 2.6. EBR Signal Descriptions

Port Name	Description	Active State
CLK	Clock	Rising Clock Edge
CE	Clock Enable	Active High
OCE ¹	Output Clock Enable	Active High
RST	Reset	Active High
BE ¹	Byte Enable	Active High
WE	Write Enable	Active High
AD	Address Bus	—
DI	Data In	—
DO	Data Out	—
CS	Chip Select	Active High
AFF	FIFO RAM Almost Full Flag	—
FF	FIFO RAM Full Flag	—
AEF	FIFO RAM Almost Empty Flag	—
EF	FIFO RAM Empty Flag	—
RPRST	FIFO RAM Read Pointer Reset	—

Notes:

- Optional signals.
- For dual port EBR primitives a trailing 'A' or 'B' in the signal name specifies the EBR port A or port B respectively.
- For FIFO RAM mode primitive, a trailing 'R' or 'W' in the signal name specifies the FIFO read port or write port respectively.
- For FIFO RAM mode primitive, FULLI has the same function as CSW(2) and EMPTYI has the same function as CSR(2).
- In FIFO mode, CLKW is the write port clock, CSW is the write port chip select, CLKR is the read port clock, CSR is the chip select, ORE is the output read enable.

The EBR memory supports three forms of write behavior for single or dual port operation:

- Normal – Data on the output appears only during the read cycle. During a write cycle, the data (at the current address) does not appear on the output. This mode is supported for all data widths.
- Write Through – A copy of the input data appears at the output of the same port. This mode is supported for all data widths.
- Read-Before-Write – When new data is being written, the old contents of the address appears at the output.

2.5.6. FIFO Configuration

The FIFO has a write port with data-in, CEW, WE and CLKW signals. There is a separate read port with data-out, RCE, RE and CLKR signals. The FIFO internally generates Almost Full, Full, Almost Empty and Empty Flags. The Full and Almost Full flags are registered with CLKW. The Empty and Almost Empty flags are registered with CLKR. [Table 2.7](#) shows the range of programming values for these flags.

Table 2.7. Programmable FIFO Flag Ranges

Flag Name	Programming Range
Full (FF)	1 to max (up to 2^N-1)
Almost Full (AF)	1 to Full-1
Almost Empty (AE)	1 to Full-1
Empty (EF)	0

N = Address bit width.

The FIFO state machine supports two types of reset signals: RST and RPRST. The RST signal is a global reset that clears the contents of the FIFO by resetting the read/write pointer and puts the FIFO flags in their initial reset state. The RPRST signal is used to reset the read pointer. The purpose of this reset is to retransmit the data that is in the FIFO. In these applications, it is important to keep careful track of when a packet is written into or read from the FIFO.

2.5.7. Memory Core Reset

The memory core contains data output latches for ports A and B. These are simple latches that can be reset synchronously or asynchronously. RSTA and RSTB are local signals, which reset the output latches associated with port A and port B respectively. The Global Reset (GSRN) signal resets both ports. The output data latches and associated resets for both ports are as shown in Figure 2.8.

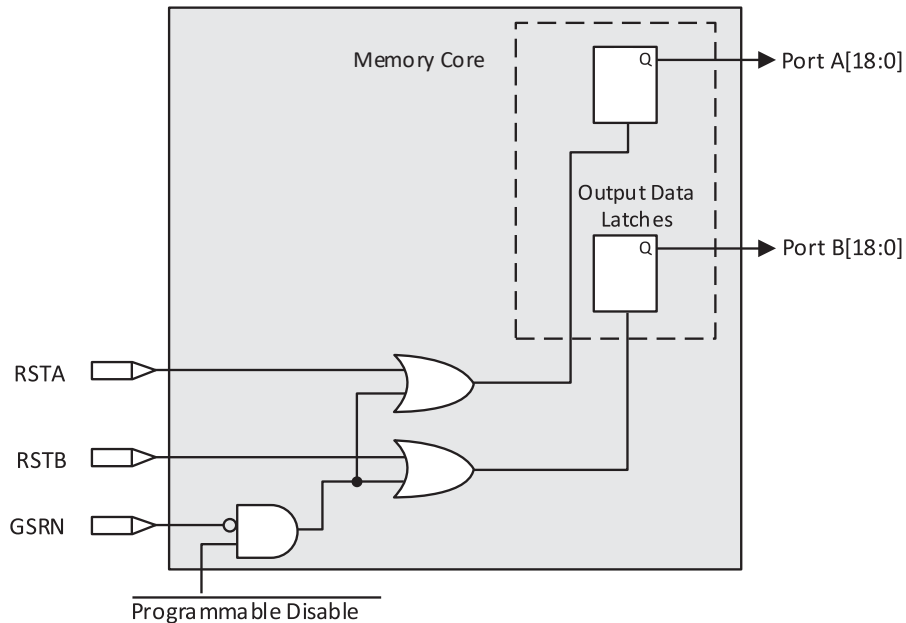

Figure 2.8. Memory Core Reset

2.5.8. EBR Asynchronous Reset

EBR asynchronous reset or GSR (if used) can only be applied if all clock enables are low for a clock cycle before the reset is applied and released a clock cycle after the reset is released, as shown in Figure 2.9. The GSR input to the EBR is always asynchronous.

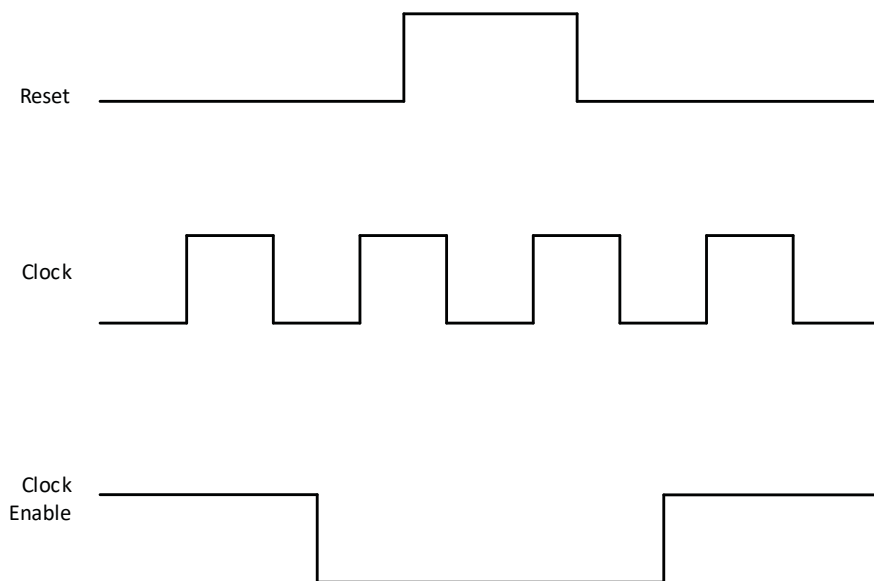

Figure 2.9. EBR Asynchronous Reset (Including GSR) Timing Diagram

If all clock enables remain enabled, the EBR asynchronous reset or GSR may only be applied and released after the EBR read and write clock inputs are in a steady state condition for a minimum of $1/f_{MAX}$ (EBR clock). The reset release must adhere to the EBR synchronous reset setup time before the next active read or write clock edge.

If an EBR is preloaded during configuration, the GSR input must be disabled or the release of the GSR during device wake up must occur before the release of the device I/O becoming active.

These instructions apply to all EBR RAM, ROM and FIFO implementations. For the EBR FIFO mode, the GSR signal is always enabled and the WE and RE signals act like the clock enable signals in [Figure 2.9](#). The reset timing rules apply to the RPreSet input versus the RE input and the RST input versus the WE and RE inputs. Both RST and RPreSet are always asynchronous EBR inputs.

Note that there are no reset restrictions if the EBR synchronous reset is used and the EBR GSR input is disabled.

2.6. Programmable I/O Cells (PIC)

The programmable logic associated with an I/O is called a PIO. The individual PIO are connected to their respective sysI/O buffers and pads. On the Mach-NX devices, the PIO cells are assembled into groups of four PIO cells called a Programmable I/O Cell or PIC. The PICs are placed on all four sides of the device.

On all the Mach-NX devices, two adjacent PIO can be combined to provide a complementary output driver pair.

All PIO pairs can implement differential receivers. Half of the PIO pairs on the top edge of these devices can be configured as true LVDS transmit pairs. The PIO pairs in Bank 2 have on-chip differential termination.

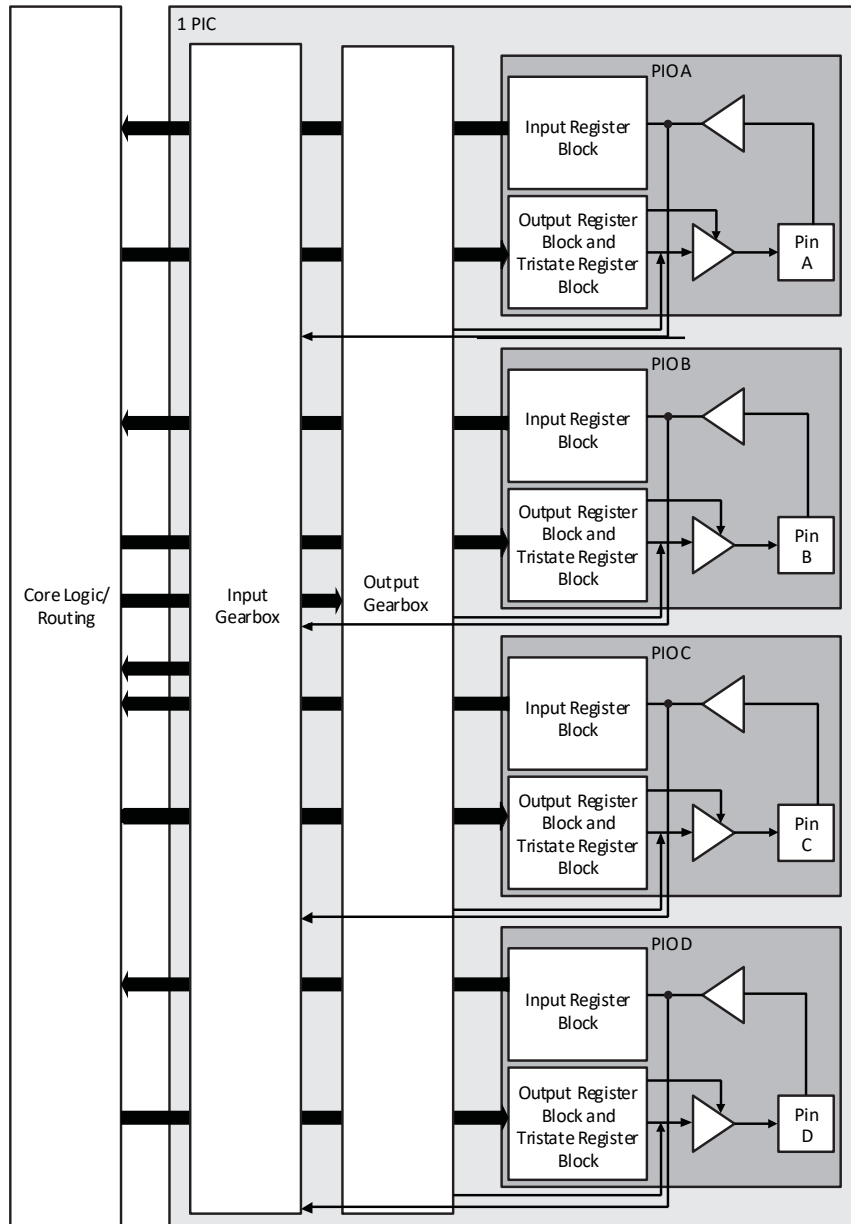

Figure 2.10. Group of Four Programmable I/O Cells

2.7. PIO

The PIO contains three blocks: an input register block, output register block, and tri-state register block. These blocks contain registers for operating in a variety of modes along with the necessary clock and selection logic.

Table 2.8. PIO Signal List

Pin Name	I/O Type	Description
CE	Input	Clock Enable
D	Input	Pin input from sysI/O buffer
INDD	Output	Register bypassed input
INCK	Output	Clock input
Q0	Output	DDR positive edge input
Q1	Output	Registered input/DDR negative edge input
D0	Input	Output signal from the core (SDR and DDR)
D1	Input	Output signal from the core (DDR)
TD	Input	Tri-state signal from the core
Q	Output	Data output signals to sysI/O Buffer
TQ	Output	Tri-state output signals to sysI/O Buffer
SCLK	Input	System clock for input and output/tri-state blocks.
RST	Input	Local set reset signal

2.7.1. Input Register Block

The input register blocks for the PIO on all edges contain delay elements and registers that can be used to condition high-speed interface signals before they are passed to the device core.

Input signals are fed from the sysI/O buffer to the input register block (as signal D). If desired, the input signal can bypass the register and delay elements and be used directly as a combinatorial signal (INDD), and a clock (INCK). If an input delay is desired, users can select a fixed delay. I/O on Bank 2 also have a dynamic delay, DEL[4:0]. The delay, if selected, reduces input register hold time requirements when using a global clock. The input block allows two modes of operation. In single data rate (SDR) the data is registered with the system clock (SCLK) by one of the registers in the single data rate sync register block. In Generic DDR mode, two registers are used to sample the data on the positive and negative edges of the system clock (SCLK) signal, creating two data streams.

2.7.2. Output Register Block

The output register block registers signals from the core of the device before they are passed to the sysI/O buffers.

In SDR mode, D0 feeds one of the flip-flops that then feeds the output. The flip-flop can be configured as a D-type register or latch.

In DDR generic mode, D0 and D1 inputs are fed into registers on the positive edge of the clock. At the next falling edge, the registered D1 input is registered into the register Q1. A multiplexer running off the same clock is used to switch the mux between the outputs of registers Q0 and Q1 that feeds the output.

Figure 2.11 shows the output register block.

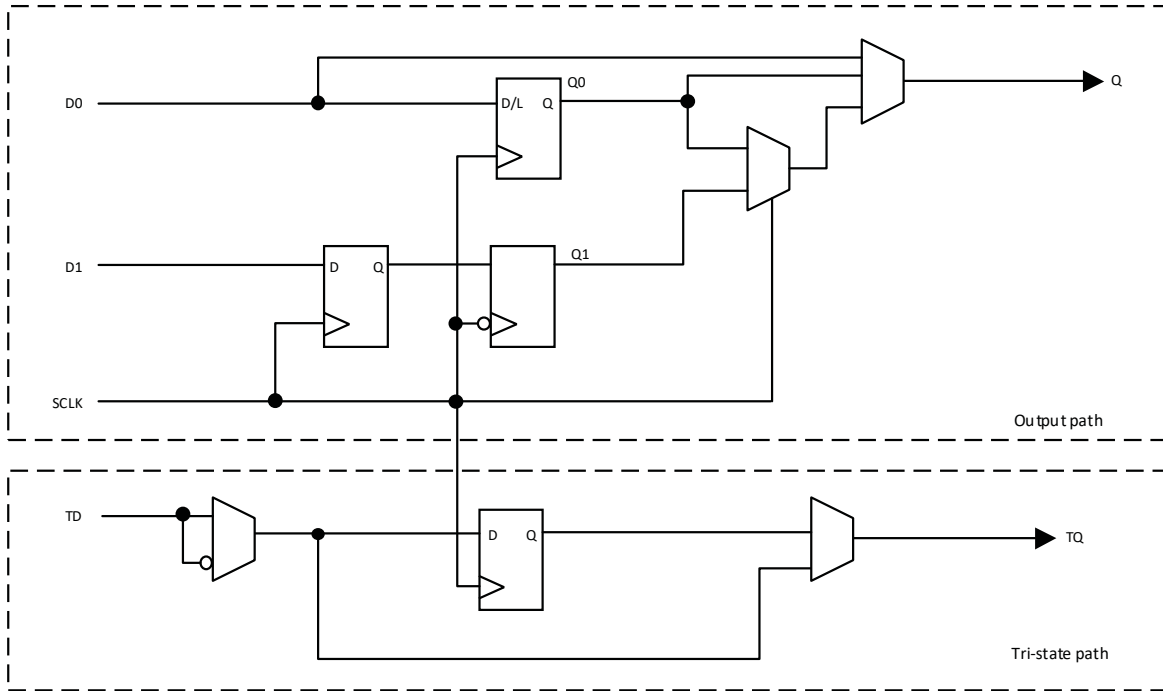

Figure 2.11. Mach-NX Output Register Block Diagram

2.7.3. Tri-state Register Block

The tri-state register block registers tri-state control signals from the core of the device before they are passed to the sysI/O buffers. The block contains a register for SDR operation. In SDR, TD input feeds one of the flip-flops that then feeds the output.

2.8. Input Gearbox

Each PIC in Bank 2 has a built-in 1:8 input gearbox. Each of these input gearboxes may be programmed as a 1:7 de-serializer or as one IDDRX4 (1:8) gearbox or as two IDDRX2 (1:4) gearboxes. [Table 2.9](#) shows the gearbox signals.

Table 2.9. Input Gearbox Signal List

Name	I/O Type	Description
D	Input	High-speed data input after programmable delay in PIO A input register block
ALIGNWD	Input	Data alignment signal from device core
SCLK	Input	Slow-speed system clock
ECLK[1:0]	Input	High-speed edge clock
RST	Input	Reset
Q[7:0]	Output	Low-speed data to device core: Video RX(1:7): Q[6:0] GDDR4(1:8): Q[7:0] GDDR2(1:4)(IOL-A): Q4, Q5, Q6, Q7 GDDR2(1:4)(IOL-C): Q0, Q1, Q2, Q3

These gearboxes have three stage pipeline registers. The first stage registers sample the high-speed input data by the high-speed edge clock on its rising and falling edges. The second stage registers perform data alignment based on the control signals UPDATE and SEL0 from the control block. The third stage pipeline registers pass the data to the device core synchronized to the low-speed system clock. [Figure 2.12](#) shows a block diagram of the input gearbox.

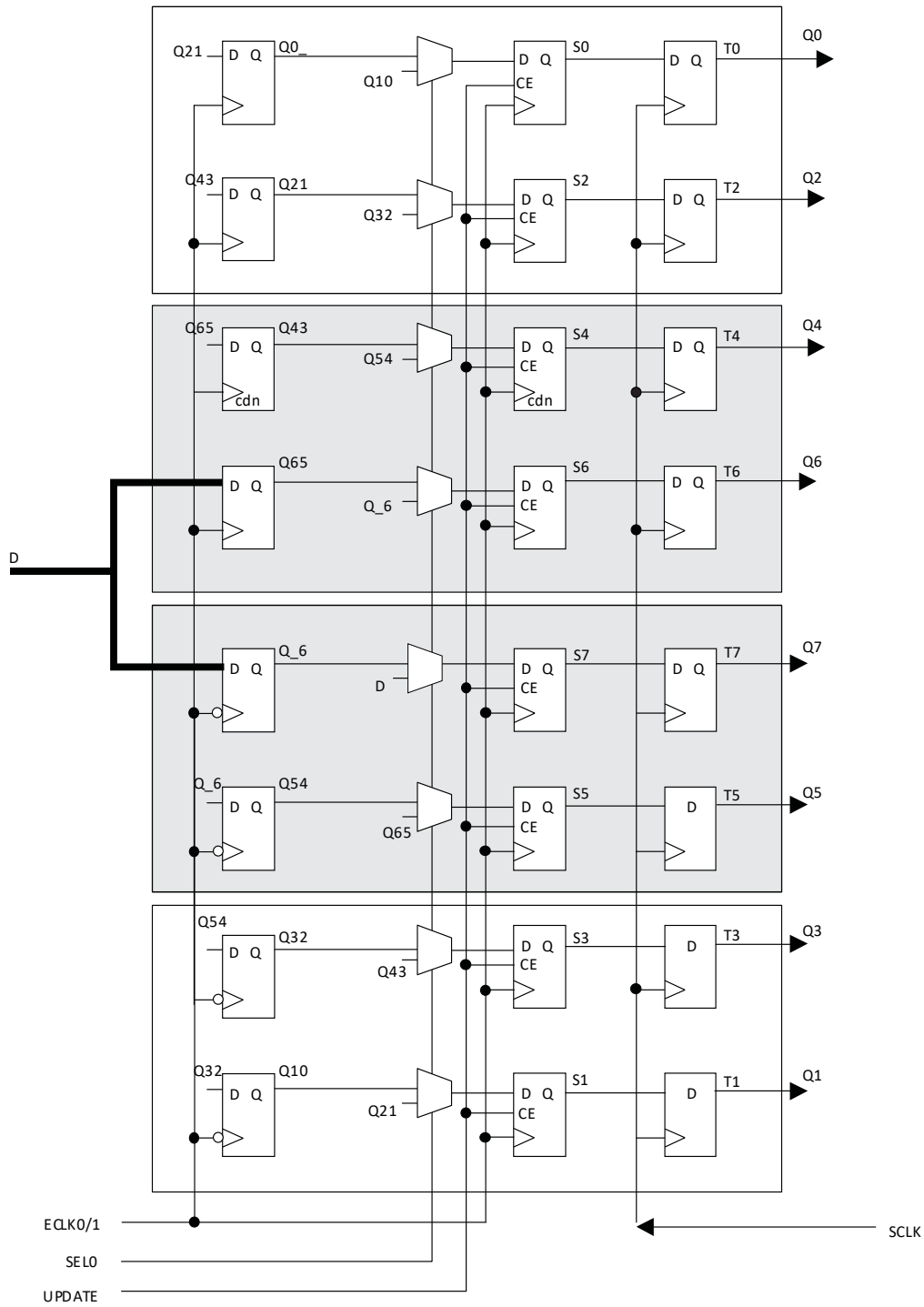

Figure 2.12. Input Gearbox

2.9. Output Gearbox

Some PIC in Bank 0 have a built-in 8:1 output gearbox. Each of these output gearboxes may be programmed as a 7:1 serializer or as one ODDR4 (8:1) gearbox or as two ODDR2 (4:1) gearboxes. [Table 2.10](#) shows the gearbox signals.

Table 2.10. Output Gearbox Signal List

Name	I/O Type	Description
Q	Output	High-speed data output
D[7:0]	Input	Low-speed data from device core
Video TX(7:1): D[6:0]	—	—
GDDR4(8:1): D[7:0]	—	—
GDDR2(4:1)(IOL-A): D[3:0]	—	—
GDDR2(4:1)(IOL-C): D[7:4]	—	—
SCLK	Input	Slow-speed system clock
ECLK [1:0]	Input	High-speed edge clock
RST	Input	Reset

The gearboxes have three stage pipeline registers. The first stage registers sample the low-speed input data on the low-speed system clock. The second stage registers transfer data from the low-speed clock registers to the high-speed clock registers. The third stage pipeline registers controlled by high-speed edge clock shift and mux the high-speed data out to the sys/O buffer. [Figure 2.13](#) shows the output gearbox block diagram.

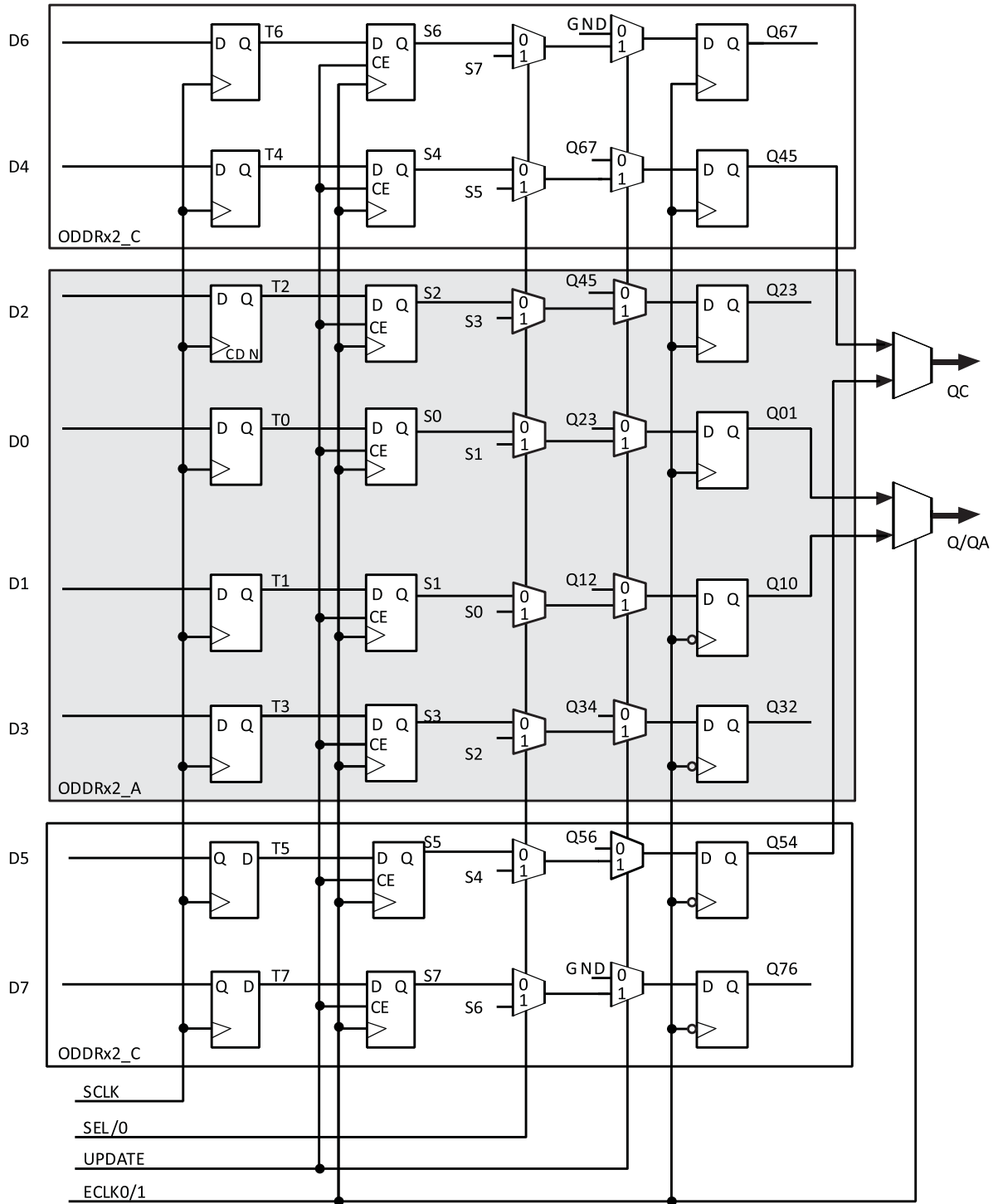

Figure 2.13. Output Gearbox

2.10. sysI/O Buffer

Each I/O is associated with a flexible buffer referred to as a sysI/O buffer. These buffers are arranged around the periphery of the device in groups referred to as banks. The sysI/O buffers allow users to implement a wide variety of standards that are found in today's systems including LVCMOS, TTL, LVDS, BLVDS, MLVDS, and LVPECL.

Each bank is capable of supporting multiple I/O standards. In the Mach-NX devices, single-ended output buffers, ratioed input buffers (LVTTL, LVCMOS), differential (LVDS) input buffers are powered using I/O supply voltage (V_{CCIO}). Each sysI/O bank has its own V_{CCIO} .

Mach-NX devices contain three types of sysI/O buffer pairs.

1. Bank 1 sysI/O Buffer Pairs

The sysI/O buffer pairs in Bank 1 of the device consist of two single-ended output drivers and two single-ended input buffers (for ratioed inputs such as LVCMOS and LVTTL). The I/O pairs in Bank 1 also have differential input buffers.

2. Bank 2 sysI/O Buffer Pairs

The sysI/O buffer pairs in Bank 2 of the device consist of two single-ended output drivers and two single-ended input buffers (for ratioed inputs such as LVCMOS and LVTTL). The I/O pairs on these banks also have differential input buffers with differential input termination.

3. Bank 0 sysI/O Buffer Pairs

The sysI/O buffer pairs in Bank 0 of the device consist of two single-ended output drivers and two single-ended input buffers (for ratioed inputs such as LVCMOS and LVTTL). The I/O pairs also have differential I/O buffers. Half of the sysI/O buffer pairs have true differential outputs. The sysI/O buffer pairs comprising of the A and B PIOs in every PIC in Bank 0 have a differential output driver.

2.10.1. Typical I/O Behavior during Power-up

The internal power-on-reset (POR) signal is deactivated when V_{CC} and V_{CCIO0} have reached VPORUP level defined in the [Power-On-Reset Voltage](#) table in the [DC and Switching Characteristics](#) section of this data sheet. After the POR signal is deactivated, the FPGA core logic becomes active. You need to ensure that all VCCIO banks are active with valid input logic levels to properly control the output logic states of all the I/O banks that are critical to the application. The default configuration of the I/O pins in a blank device is tri-state with a weak pull-down to GND (some pins such as PROGRAMN and the JTAG pins have weak pull-up to VCCIO as the default functionality). The I/O pins maintain the blank configuration until VCC and VCCIO (for I/O banks containing configuration I/O) reach VPORUP levels at which time the I/O takes on the user-configured settings only after a proper download/configuration.

There are various ways for you to ensure that there are no spurious signals on critical outputs as the device powers up.

2.10.2. Supported Standards

The Mach-NX sysI/O buffer supports both single-ended and differential standards. Single-ended standards can be further subdivided into LVCMOS and LVTTL. The buffer supports the LVTTL, LVCMOS 1.2 V, 1.5 V, 1.8 V, 2.5 V, and 3.3 V standards. In the LVCMOS and LVTTL modes, the buffer has individually configurable options for drive strength, bus maintenance (weak pull-up, weak pull-down, bus-keeper latch or none) and open drain. BLVDS, MLVDS and LVPECL output emulation is supported on all devices. The Mach-NX devices support on-chip LVDS output buffers on approximately 30% of the I/O on Bank 1. Differential receivers for LVDS, BLVDS, MLVDS, and LVPECL are supported on select banks of Mach-NX devices.

Table 2.11 summarizes the I/O characteristics of the Mach-NX FPGAs and shows the I/O standards, together with their supply and reference voltages, supported by the Mach-NX devices.

Table 2.11. Supported Input Standards

Input Standard	V _{CCIO} (Typ.)				
	3.3 V	2.5 V	1.8 V	1.5 V	1.2 V
Single-Ended Interfaces					
LVTTL	Yes	Yes ²	Yes ²	Yes ²	—
LVCMOS33	Yes	Yes ²	Yes ²	Yes ²	—
LVCMOS25	Yes ²	Yes	Yes ²	Yes ²	—
LVCMOS18	Yes ²	Yes ²	Yes	Yes ²	—
LVCMOS15	Yes ²	Yes ²	Yes ²	Yes	Yes ²
LVCMOS12	Yes ²	Yes ²	Yes ²	Yes ²	Yes
LVCMOS10R25	—	Yes ³	—	—	—
LVCMOS10R33	Yes ³	—	—	—	—
Differential Interfaces					
LVDS	Yes	Yes	—	—	—
BLVDS, MLVDS, LVPECL, RSDS	Yes	Yes	—	—	—
MIPI ¹	Yes	Yes	—	—	—
LVTTL D	Yes	Yes ²	—	—	—
LVCMOS33D	Yes	—	—	—	—
LVCMOS25D	Yes	Yes	—	—	—
LVCMOS18D	Yes	Yes	Yes	—	—

Notes:

1. These interfaces can be emulated with external resistors in all devices.
2. For reduced functionality, refer to [Mach-NX sys/I/O Usage Guide \(FPGA-TN-02233\)](#) for more details.
3. This input standard can be supported with the referenced input buffer.

Table 2.12. Supported Output Standards

Output Standard	V _{CCIO} (Typ.)
Single-Ended Interfaces	
LVTTL	3.3
LVCMOS33	3.3
LVCMOS25	2.5
LVCMOS18	1.8
LVCMOS15	1.5
LVCMOS12	1.2
LVCMOS10R25, Open Drain	—
LVCMOS10R33, Open Drain	—
LVCMOS33, Open Drain	—
LVCMOS25, Open Drain	—
LVCMOS18, Open Drain	—
LVCMOS15, Open Drain	—
LVCMOS12, Open Drain	—

Output Standard	V _{CCIO} (Typ.)
Differential Interfaces	
LVDS*	2.5, 3.3
BLVDS, MLVDS, RSDS*	2.5
LVPECL*	3.3
MIPI*	2.5
LVTTL	3.3
LVC MOS33D	3.3
LVC MOS25D	2.5
LVC MOS18D	1.8

*Note: These interfaces can be emulated with external resistors in all devices.

2.10.3. sysI/O Buffer Banks

Mach-NX device has seven banks. Figure 2.14 shows the three sysI/O banks, from Bank 0 to Bank 2, and their associated supplies for all devices. Bank 3 to Bank 6 (which are not user definable I/O types) are also shown with their associated supplies.

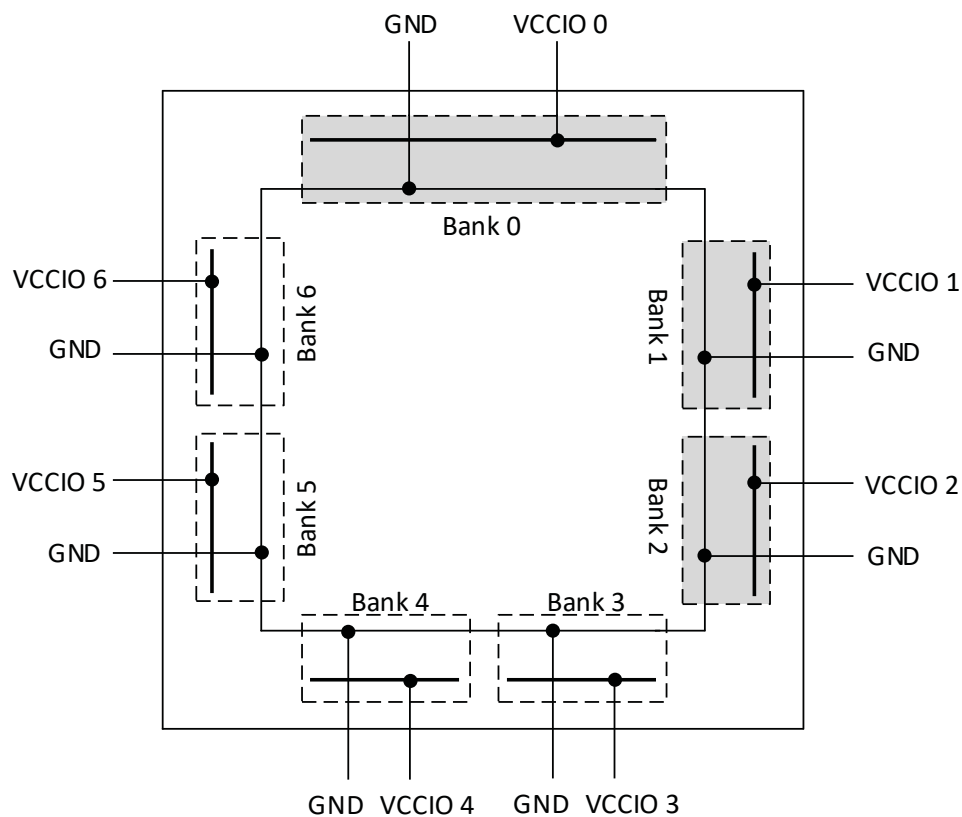

Figure 2.14. Mach-NX I/O Banks

2.11. Hot Socketing

The Mach-NX devices are carefully designed to ensure predictable behavior during power-up and power-down. Leakage into I/O pins is controlled to within specified limits. This allows for easy integration with the rest of the system. These capabilities make the Mach-NX device ideal for many multiple power supply and hot-swap applications.

2.12. On-chip Oscillator

Every Mach-NX device has an internal CMOS oscillator. The oscillator output can be routed as a clock to the clock tree or as a reference clock to the sysCLOCK PLL using general routing resources. The oscillator frequency can be divided by internal logic. There is a dedicated programming bit and a user input to enable/disable the oscillator. The oscillator frequency ranges from 2.08 MHz to 133 MHz.

2.13. Hardened SoC

Figure 2.15 shows the SoC Block Diagram in the Mach-NX device. The system design consists of a RISC-V processor connected to a set of peripherals through the AHB Lite bus. The software running on the processor controls the general and PFR solution peripherals and handles all the events at runtime to perform the system functionalities.

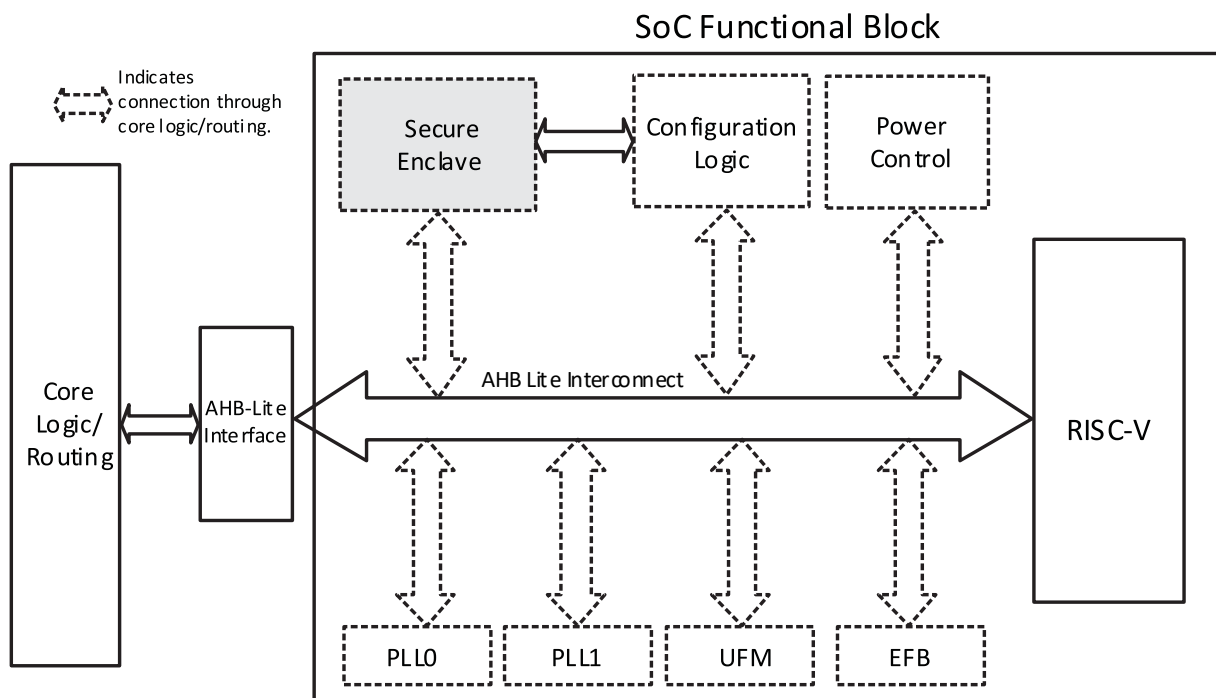

Figure 2.15. Embedded Function Block Interface

2.13.1. Embedded Hardened IP Functions through SoC

All Mach-NX devices provide embedded hardened functions such as User Flash Memory (UFM). These embedded blocks are accessed via a slave AHB-Lite bus mastered by the SoC as shown in Figure 2.16. For security block, it also has the high-speed interface with routing.

- 32-bit RISC-V processor and embedded peripherals
 - On chip System Memory
 - Timer
 - I²C/SMBus Slaves
 - QSPI Master

- QSPI Monitor
- I²C Monitor
- GPIO

2.13.2. Secure Enclave

Every Mach-NX device contains one Secure Enclave IP core as part of the SoC. The core is responsible for all the security related functions, including encryption, authentication, and key generation in both configuration and user modes.

Secure Enclave provides the following major functions:

- Secure Hash Algorithm (SHA) — 256 bits
- Elliptic Curve Digital Signature Algorithm (ECDSA) — Generation and verification
- Message Authentication Codes (MACs) — Hash-based MAC (HMAC)
- Elliptic Curve Diffie-Hellman (ECDH) Scheme
- Elliptic Curve Cryptography (ECC) Key Pair Generation — Public key/Private key
- Elliptic Curve Illustrated Encryption Standard (ECIES) Encryption/Decryption
- True Random Number Generator (TRNG)
- Advanced Encryption Standard (AES) — 128/256 bits
- Authentication controller for configuration engine
- Slave AHB-Lite bus, mastered by the SoC
- High Speed Port (HSP) for FIFO-based streaming data transfer
- Unique Secure ID

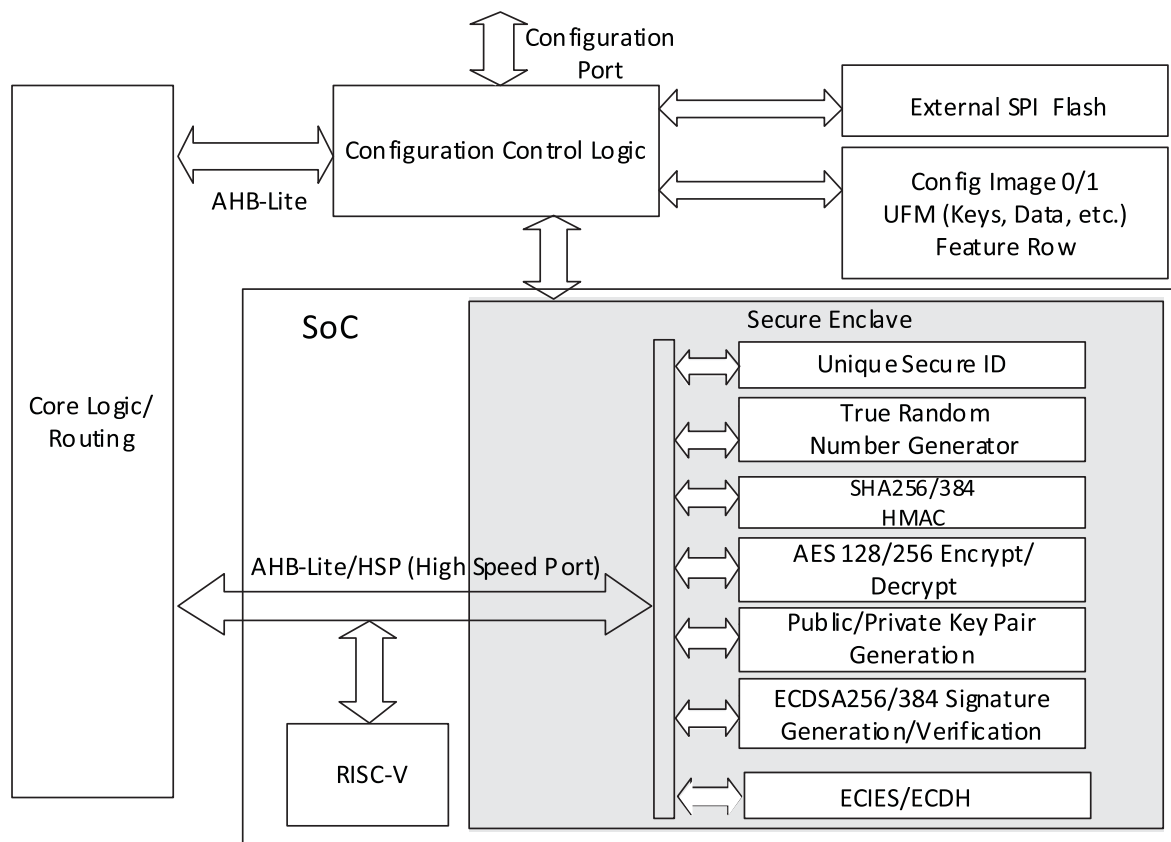

Figure 2.16. Secure Enclave Core Block Diagram

To ensure the security and authenticity of the configuration bitstream, Mach-NX devices offer the following features:

- Bitstream Encryption
- Bitstream Authentication
- Bitstream Encryption and Authentication

When encryption is enabled, Diamond software encrypts the bitstream using AES key. When authentication is enabled, Lattice Diamond software attaches a certificate, which is based on the bitstream digest to the bitstream using customer's private key from the public/private ECDSA key pair. When both features are enabled, Lattice Diamond software generates the bitstream digest and attaches the ECDSA certificate/signature to this bitstream first. In the second step, this bitstream with the signature is encrypted using the AES Key.

When programming the bitstream to the configuration image space, AES decryption and authentication are executed based on the associated AES/ECDSA public key. Once the authentication is successful, the programming is complete and the "Done" bit is set. If the authentication is unsuccessful, the Mach-NX device stays in an unprogrammed state. After programming successfully, the Mach-NX SRAM is configured from flash to enter normal mode after power-cycling, refresh, or ProgramN toggling. It is optional to run the authentication again for each configuration with the selection of fast boot.

There are multiple hard/soft lock controls to enable the reading and writing of specific Flash location, configuration or UFM, for the high security application with the OTP option to prevent any further change to the device.

Mach-NX device provides a unique, immutable key known with Unique Secure ID. Unique Secure ID is used by Secure Enclave to generate paired public key, to perform AES encryption and decryption, and to provide other security related functions. This Unique Secure ID is unique for every device, never leaves the device and is inaccessible. No peripheral can reach the Unique Secure ID including the device's own fabric.

User logic in the fabric can also access security functions in the Secure Enclave through a slave AHB-Lite bus mastered by the SoC for the control and status register access. Payload data transfer in and out of the Secure Enclave is enabled through a FIFO-based pipelined High Speed Port. For example, the Mach-NX device can be used to authenticate the microcontroller firmware image stored in the SPI memory chip attached to the Mach-NX device before booting the microcontroller. Here the High Speed Port with the Secure Enclave can be used to transfer the contents stored in the SPI memory into the Secure Enclave for digesting of the firmware image, a step associated with the overall ECDSA authentication of the microcontroller firmware.

2.14. User Flash Memory (UFM)

Mach-NX devices provide a UFM block that can be used for a variety of applications including storing a portion of the configuration image, initializing EBRs to store PROM data or, as a general purpose user Flash memory. It also has a dedicated block for the user key storage and lock control. The UFM block connects to the device core through a slave AHB-Lite bus mastered by the SoC. You can also access the UFM block through the JTAG, I²C, and SPI interfaces of the device. The UFM block offers the following features:

- Non-volatile storage up to 1064 kb
- Dedicated 172 kb non-volatile storage (UFM2) for user key
- 100K write cycles
- Write access is performed page-wise; each page has 128 bits (16 bytes)
- Auto-increment addressing
- AHB-Lite slave port

Table 2.13. Mach-NX UFM Size

Device	UFM0 (kbit)	UFM1 (kbit)	UFM2 (kbit)	CFG1 (kbit)*
LFMNX-50	458	458	147	1,605

*Note: When the dual boot feature is disabled, the CFG1 space can be repurposed as the additional UFM usage.

2.15. Standby Mode and Power Saving Options

Mach-NX devices are designed with features that allow users to meet the static and dynamic power requirements of their applications by controlling various device subsystems such as the band gap, power-on-reset circuitry, I/O bank controllers, power guard, on-chip oscillator, PLLs, and others. In order to maximize power savings, Mach-NX devices support a low power Stand-by mode.

In the standby mode, the Mach-NX devices are powered on and configured. Internal logic, I/O and memories are switched on and remain operational, as the user logic waits for an external input. The device enters this mode when the standby input of the standby controller is toggled or when an appropriate I²C or JTAG instruction is issued by an external master. Various subsystems in the device such as the band gap, power-on-reset circuitry can be configured such that they are automatically turned “off” or go into a low power consumption state to save power when the device enters this state. Note that the Mach-NX devices are powered on when in standby mode and all power supplies should remain in the Recommended Operating Conditions.

Table 2.14. Mach-NX Power Saving Features Description

Device Subsystem	Feature Description
Band gap	The band gap can be turned off in standby mode. When the band gap is turned off, analog circuitry such as the POR, PLLs, on-chip oscillator, and differential I/O buffers are also turned off.
Power-On-Reset (POR)	The POR can be turned off in standby mode. This monitors VCC levels. In the event of unsafe VCC drops, this circuit reconfigures the device. When the POR circuitry is turned off, limited power detector circuitry is still active. This option is only recommended for applications in which the power supply rails are reliable.
On-Chip Oscillator	The on-chip oscillator has two power saving features. It may be switched off if it is not needed in your design. It can also be turned off in Standby mode.
PLL	Similar to the on-chip oscillator, the PLL also has two power saving features. It can be statically switched off if it is not needed in a design. It can also be turned off in Standby mode. The PLL waits until all output clocks from the PLL are driven low before powering off.
I/O Bank Controller	Differential I/O buffers (used to implement standards such as LVDS) consume more than ratioed single-ended I/O such as LVCMOS and LVTTTL. The I/O bank controller allows you to turn these I/O off dynamically on a per bank selection.
Dynamic Clock Enable for Primary Clock Nets	Each primary clock net can be dynamically disabled to save power.
Power Guard	Power Guard is a feature implemented in input buffers. This feature allows users to switch off the input buffer when it is not needed. This feature can be used in both clock and data paths. Its biggest impact is that in the standby mode it can be used to switch off clock inputs that are distributed using general routing resources.

2.16. Power-On Reset

Mach-NX devices have power-on reset circuitry to monitor V_{CCINT} and V_{CCIO} voltage levels during power-up and operation. At power-up, the POR circuitry monitors V_{CCINT} and V_{CCIO0} (controls configuration) voltage levels. It then triggers download from the on-chip configuration Flash memory after reaching the V_{PORUP} level specified in the [Power-On-Reset Voltage](#) table in the [DC and Switching Characteristics](#) section of this data sheet. For “C” devices with voltage regulators, V_{CCINT} is regulated from the V_{CC} supply voltage. From this voltage reference, the time taken for configuration and entry into user mode is specified as Flash Download Time ($t_{REFRESH}$) in the [DC and Switching Characteristics](#) section of this data sheet. Before and during configuration, the I/O are held in tri-state. I/O are released to user functionality once the device has finished configuration.

Once the device enters into user mode, the POR circuitry can optionally continue to monitor V_{CCINT} levels. If V_{CCINT} drops below $V_{PORDNBG}$ level (with the band gap circuitry switched on) or below $V_{PORDNSRAM}$ level (with the band gap circuitry switched off to conserve power) device functionality cannot be guaranteed. In such a situation the POR issues a reset and begins monitoring the V_{CCINT} and V_{CCIO} voltage levels. $V_{PORDNBG}$ and $V_{PORDNSRAM}$ are both specified in the [Power-On-Reset Voltage](#) table in the [DC and Switching Characteristics](#) section of this data sheet.

When the band gap circuitry is switched off, the POR circuitry also shuts down. The device is designed such that a minimal, low power POR circuit is still operational (this corresponds to the $V_{PORDNSRAM}$ reset point described in the paragraph above). However, this circuit is not as accurate as the one that operates when the band gap is switched on. The low power POR circuit emulates an SRAM cell and is biased to trip before the vast majority of SRAM cells flip. If you are concerned about the V_{CC} supply dropping below $V_{CC}(\min)$, do not shut down the band gap or POR circuit.

2.17. Configuration and Testing

This section describes the configuration and testing features of the Mach-NX family.

2.17.1. IEEE 1149.1-Compliant Boundary Scan Testability

All Mach-NX devices have boundary scan cells that are accessed through an IEEE 1149.1 compliant test access port (TAP). This allows functional testing of the circuit board, on which the device is mounted, through a serial scan path that can access critical logic nodes. Internal registers are linked internally, allowing test data to be shifted in and loaded directly onto test nodes, or test data to be captured and shifted out for verification. The test access port consists of dedicated I/O: TDI, TDO, TCK and TMS. The test access port shares its power supply with V_{CCIO} Bank 0 and can operate with LVCMOS3.3, 2.5, 1.8, 1.5, and 1.2 standards.

For more details on boundary scan test, see [Boundary Scan Testability with Lattice sysI/O Capability \(AN8066\)](#) and [Minimizing System Interruption During Configuration Using TransFR Technology \(TN1087\)](#).

2.17.2. Device Configuration

All Mach-NX devices contain two ports that can be used for device configuration. The Test Access Port (TAP), which supports bit-wide configuration and the sysCONFIG port, which supports serial configuration through I²C or SPI. The TAP supports both the IEEE Standard 1149.1 Boundary Scan specification and the IEEE Standard 1532 In-System Configuration specification. There are various ways to configure a Mach-NX device:

- Internal Flash Download
- JTAG
- System microprocessor to drive a serial slave SPI port (SSPI mode)
- Standard I²C Interface to system microprocessor

Upon power-up, the configuration SRAM is ready to be configured using the selected sysCONFIG port. Once a configuration port is selected, it remains active throughout that configuration cycle. The IEEE 1149.1 port can be activated any time after power-up by sending the appropriate command through the TAP port. Optionally, the device can run a CRC check upon entering the user mode. This ensures that the device was configured correctly.

The sysCONFIG port has 10 dual-function pins, which can be used as general purpose I/O, if they are not required for configuration.

Lattice design software uses proprietary compression technology to compress bit-streams for use in Mach-NX devices. Use of this technology allows Lattice Semiconductor to provide a lower cost solution. In the unlikely event that this technology is unable to compress bitstreams to fit into the amount of on-chip Flash, there are a variety of techniques that can be utilized to allow the bitstreams to fit into the on-chip Flash.

2.17.2.1. Encryption & Authentication

With the FPGA, Mach-NX device can provide highly secured control for the device programming and configuration. It uses ECDSA256 algorithm for Configuration Image Authentication. It has the AES256 encryption for additional security and IP protection.

2.17.2.2. Transparent Field Reconfiguration (TransFR)

TransFR is a unique Lattice technology that allows users to update their logic in the field without interrupting system operation using a simple push-button solution. For more details, refer to [Minimizing System Interruption During Configuration Using TransFR Technology \(TN1087\)](#) for details.

2.17.2.3. Lock Bits and Lock Control Policy

Mach-NX device has read, program, and erase permission control for external CFG ports and for internal AHB-Lite bus to access Flash sectors. External CFG ports include JTAG, slave SPI, and slave I²C. The way to support this feature is to deploy three permission control setting bits for each sectors as SEC_READ, SEC_PROG, and SEC_ERASE.

- SEC_READ — Disable the READ access. This prevents user content from being exposed to external CFG port.
- SEC_PROG— Disable the PROGRAM access. This prevents unexpected incremental programming to modify the current user setting, such as AES KEY, ECDSA PUBLIC KEY or authenticated Bitstream, and others.
- SEC_ERASE— Disable the ERASE access. This prevents unexpected incremental programming to modify the current user setting, such as AES KEY, ECDSA PUBLIC KEY or authenticated Bitstream, and others. This also ensures a safe boot up.

Mach-NX device also provides *Hard Lock* and *Soft Lock* modes for flexible permission control. *Soft Lock* means the security setting bits can be modified by internal AHB-Lite bus. In this way, user logic can enable or disable the access by altering the security control bits through internal AHB-Lite Bus. *Hard Lock* mode means user logic cannot alter permission control bits through internal AHB-Lite bus. The SEC_HLOCK bit is used to choose between the *Soft Lock* and *Hard Lock* modes.

For detailed information regarding Lock Bits and Lock Control Policy, refer to [Mach-NX Programming and Configuration Usage Guide \(FPGA-TN-02231\)](#).

2.17.2.4. Tamper Detection and Response

Configuration logic automatically detects a variety of threat from configuration ports. These threats include any commands/instructions that:

- Try to access Flash/SRAM without entering password or with entering wrong password, if password protection is enabled.
- Try to access Flash/SRAM that is under Soft/Hard Lock protection.
- Attempt to enter MANUFACTURE mode.
- Shift in a wrong password by LSC_SHIFT_PASSWORD.

The Configuration module asserts *threat detect* to user logic once the enabled type of threat has been detected. Also, the Configuration module reports which type of threat is detected and from which configuration port the threat comes.

Once a certain threat has been detected, User logic may inform the Configuration module to disable configuration ports to avoid a dictionary style attack.

2.17.2.5. Password

The Mach-NX device maintains the legacy support for password-based security access feature also known as Flash Protect Key. The Flash Protect Key feature provides a method of controlling access to the Configuration and Programming modes of the device. When enabled, the Configuration and Programming edit mode operations including

Write, Verify and Erase operations are allowed only when coupled with a Flash Protect Key, which matches that expected by the device. Without a valid Flash Protect Key, you can perform only rudimentary non-configuration operations such as Read Device ID.

2.17.2.6. On-chip Dual Boot

Mach-NX devices can optionally boot from two patterns, a primary bitstream and a golden bitstream. If the primary bitstream is found to be corrupt while being downloaded into the SRAM, the device shall then automatically re-boot from the golden bitstream. Mach-NX device also supports the option to boot from the latest image in a ping-pong style, or user select for the boot image.

2.17.2.7. Soft Error Detection

The Soft Error Detection (SED) feature is a CRC check of the SRAM cells after the device is configured. This check ensures that the SRAM cells were configured successfully. This feature is enabled by a configuration bit option. The Soft Error Detection (SED) can also be initiated in user mode via an input to the fabric. The clock for the Soft Error Detection (SED) circuit is generated using a dedicated divider. The undivided clock from the on-chip oscillator is the input to this divider. For low power applications, you can switch off the Soft Error Detection circuit.

2.17.2.8. Soft Error Correction

The Mach-NX device supports Soft Error Correction (SEC). When BACKGROUND_RECONFIG is enabled using the Lattice Diamond Software in a design, asserting the PROGRAMN pin or issuing the REFRESH sysConfig command refreshes the SRAM array from configuration memory. Only the detected error bit is corrected. No other SRAM cells are changed, allowing the user design to function uninterrupted.

During the project design phase, if the overall system cannot guarantee containment of the error or its subsequent effects on downstream data or control paths, Lattice Semiconductor recommends using SED only. Mach-NX device can then be soft-reset by asserting PROGRAMN or issuing the Refresh command over a sysConfig port in response to SED. Soft-reset additionally erases the SRAM array prior to the SRAM refresh, and asserts internal Reset circuitry to guarantee a known state.

2.18. TraceID

Each Mach-NX device contains a unique (per device) TraceID that can be used for tracking purposes or for IP security applications. The TraceID is 64 bits long. Eight out of 64 bits are user-programmable, the remaining 56 bits are factory-programmed. The TraceID is accessible through the slave AHB-Lite bus mastered by the SoC and can also be accessed through the SPI, I²C, or JTAG interfaces.

3. DC and Switching Characteristics

3.1. Absolute Maximum Rating

Table 3.1. Absolute Maximum Rating^{1, 2, 3}

	Min	Max	Unit
Supply Voltage V_{CC}	-0.5	1.10	V
Supply Voltage V_{CCB} , V_{CCAUX}	-0.5	1.98	V
I/O Supply Voltage $V_{CCIO0,1,2,5,6}$	-0.5	3.63	V
I/O Supply Voltage $V_{CCIO3,4}$	-0.5	1.98	V
I/O Tri-state Voltage Applied ^{4,5}	-0.5	3.75	V
Dedicated Input Voltage Applied ⁴	-0.5	3.75	V
Storage Temperature (Ambient)	-55	125	°C
Junction Temperature (T_J)	-40	125	°C

Notes:

1. Stress above those listed under the “Absolute Maximum Ratings” may cause permanent damage to the device. Functional operation of the device at these or any other conditions above those indicated in the operational sections of this specification is not implied.
2. Compliance with the [Lattice Thermal Management \(FPGA-TN-02044\)](#) document is required.
3. All voltages referenced to GND.
4. Overshoot and undershoot of -2 V to (VIHMAX + 2) volts is permitted for a duration of <20 ns.
5. The dual function I2C pins SCL and SDA are limited to -0.25 V to 3.75 V or to -0.3 V with a duration of <20 ns.

3.2. Recommended Operating Conditions

Table 3.2. Recommended Operating Conditions¹

Symbol	Parameter	Conditions	Min.	Typ.	Max.	Units
V_{CC}^1	Core Supply Voltage	$V_{CC} = 1.0$	0.95	1.0	1.05	V
V_{CCB}	Auxiliary core supply voltage	—	1.746	1.8	1.98	V
$V_{CCIO0,1,2,5,6}^{1, 2, 3}$	I/O Driver Supply Voltage	$V_{CCIO} = 3.3$	3.135	3.30	3.465	V
$V_{CCIO0,1,2,5,6}^{1, 2, 3}$		$V_{CCIO} = 2.5$	2.375	2.50	2.625	V
$V_{CCIO1,2,3,4,5,6}^{1, 2, 3}$		$V_{CCIO} = 1.8$	1.71	1.80	1.89	V
$V_{CCIO1,2,3,4,5,6}^{1, 2, 3}$		$V_{CCIO} = 1.5$	1.425	1.50	1.575	V
$V_{CCIO3,4}^{1, 2, 3}$		$V_{CCIO} = 1.35$ (For DDR3L Only)	1.2825	1.35	1.4175	V
$V_{CCIO1,2,3,4,5,6}^{1, 2, 3}$		$V_{CCIO} = 1.2$	1.14	1.20	1.26	V
$V_{CCIO3,4}^{1, 2, 3}$		$V_{CCIO} = 1.0$	0.95	1.00	1.05	V
t_{JCOM}		Junction Temperature Commercial Operation	—	0	—	85
t_{JIND}	Junction Temperature Industrial Operation	—	-40	—	100	°C

Notes:

1. Like power supplies must be tied together. For example, if V_{CCIO} and V_{CC} are both the same voltage, they must also be the same supply.
2. See recommended voltages by I/O standard in subsequent table.
3. V_{CCIO} pins of unused I/O banks should be connected to the V_{CC} power supply on boards.

3.3. Power Supply Ramp Rates

Table 3.3. Power Supply Ramp Rates

Symbol	Parameter	Min.	Typ.	Max.	Units
t_{RAMP}	Power supply ramp rates for all power supplies.	0.01	—	40	V/ms

Note: Assumes monotonic ramp rates.

3.4. Power-On Reset Voltage Levels

Table 3.4. Power-On Reset Voltage Levels

Symbol	Parameter	Min.	Typ.	Max.	Units
V_{PORUP}	Power-On-Reset ramp up trip point (band gap based circuit monitoring V_{CCINT} and V_{CCIO0})	0.90	—	1.06	V
$V_{PORUPEXT}$	Power-On-Reset ramp up trip point (band gap based circuit monitoring external V_{CC} power supply)	1.50	—	2.10	V
$V_{PORDNBG}$	Power-On-Reset ramp down trip point (band gap based circuit monitoring V_{CCINT})	0.75	—	1.04	V
$V_{PORDNBGEXT}$	Power-On-Reset ramp down trip point (band gap based circuit monitoring V_{CC})	0.98	—	1.44	V
$V_{PORDNSRAM}$	Power-On-Reset ramp down trip point (SRAM based circuit monitoring V_{CCINT})	—	0.84	—	V
$V_{PORDNSRAMEXT}$	Power-On-Reset ramp down trip point (SRAM based circuit monitoring V_{CC})	—	1.16	—	V

Notes:

- These POR trip points are only provided for guidance. Device operation is only characterized for power supply voltages specified under recommended operating conditions.
- V_{PORUP} (min.) and $V_{PORDNBG}$ (max.) are in different process corners. For any given process corner $V_{PORDNBG}$ (max.) is always 12.0 mV below V_{PORUP} (min.).
- V_{CCIO0} does not have a Power-On-Reset ramp down trip point. V_{CCIO0} must remain within the Recommended Operating Conditions to ensure proper operation.

3.5. Hot Socketing Specifications

Table 3.5. Hot Socketing Specifications

Symbol	Parameter	Condition	Max.	Units
I_{DK}	Input or I/O leakage Current	$0 < V_{IN} < V_{IH}$ (MAX)	± 1.5	mA

Notes:

- Insensitive to sequence of V_{CC} and V_{CCIO} . However, assumes monotonic rise/fall rates for V_{CC} and V_{CCIO} .
- $0 < V_{CC} < V_{CC} (MAX)$, $0 < V_{CCIO} < V_{CCIO} (MAX)$.
- I_{DK} is additive to I_{PU} , I_{PD} or I_{BH} .
- Hot socket specification defines when the hot socketed device junction temperature is at 85 °C or below. When the hot socketed device junction temperature is above 85 °C, the IDK current can exceed the above spec.

3.6. Programming/Erase Specifications

Table 3.6. Programming/Erase Specifications

Symbol	Parameter	Min	Max.	Units
N _{PROGCYC}	Flash Programming cycles per t _{RETENTION}	—	1,000	Cycles
	Flash Write/Erase cycles	—	10,000	
t _{RETENTION}	Data retention at 100°C junction temperature	10	—	Years
	Data retention at 85°C junction temperature	20	—	

Notes:

- Maximum Flash memory reads are limited to 7.5E13 cycles over the lifetime of the product.
- A Write/Erase cycle is defined as any number of writes over time followed by any erase cycle.

3.7. ESD Performance

Refer to the Mach-NX Product Family Qualification Summary for complete qualification data, including ESD performance.

3.8. DC Electrical Characteristics

Over Recommended Operating Conditions

Table 3.7. DC Electrical Characteristics

Symbol	Parameter	Condition	Min.	Typ.	Max.	Units
I _{IL} , I _{IH} ^{1, 4}	Input or I/O Leakage	Clamp OFF and V _{CCIO} < V _{IN} < V _{IH} (MAX)	—	—	175	μA
		Clamp OFF and V _{IN} = V _{CCIO}	-10	—	10	μA
		Clamp OFF and V _{CCIO} - 0.97 V < V _{IN} < V _{CCIO}	-175	—	—	μA
		Clamp OFF and 0 V < V _{IN} < V _{CCIO} - 0.97 V	—	—	10	μA
		Clamp OFF and V _{IN} = GND	—	—	10	μA
		Clamp ON and 0 V < V _{IN} < V _{CCIO}	—	—	10	μA
I _{PU}	I/O Active Pull-up Current	0 < V _{IN} < 0.7 V _{CCIO}	-30	—	-309	μA
I _{PD}	I/O Active Pull-down Current	V _{IL} (MAX) < V _{IN} < V _{CCIO}	30	—	305	μA
I _{BHLS}	Bus Hold Low sustaining current	V _{IN} = V _{IL} (MAX)	30	—	—	μA
I _{BHHS}	Bus Hold High sustaining current	V _{IN} = 0.7V _{CCIO}	-30	—	—	μA
I _{BHLO}	Bus Hold Low Overdrive current	0 ≤ V _{IN} ≤ V _{CCIO}	—	—	305	μA
I _{BHHO}	Bus Hold High Overdrive current	0 ≤ V _{IN} ≤ V _{CCIO}	—	—	-309	μA
V _{BHT} ³	Bus Hold Trip Points	—	V _{IL} (MAX)	—	V _{IH} (MIN)	V
C1	I/O Capacitance ²	V _{CCIO} = 3.3 V, 2.5 V, 1.8 V, 1.5 V, 1.2 V, V _{CCIO} = Typ., V _{IO} = 0 to V _{IH} (MAX)	3	5	9	pf
V _{HYST}	Hysteresis for Schmitt Trigger Inputs ⁵	V _{CCIO} = 3.3 V, Hysteresis = Large	—	450	—	mV
		V _{CCIO} = 2.5 V, Hysteresis = Large	—	250	—	mV
		V _{CCIO} = 1.8 V, Hysteresis = Large	—	125	—	mV
		V _{CCIO} = 1.5 V, Hysteresis = Large	—	100	—	mV
		V _{CCIO} = 3.3 V, Hysteresis = Small	—	250	—	mV
		V _{CCIO} = 2.5 V, Hysteresis = Small	—	150	—	mV
		V _{CCIO} = 1.8 V, Hysteresis = Small	—	60	—	mV
		V _{CCIO} = 1.5 V, Hysteresis = Small	—	40	—	mV

Notes:

1. Input or I/O leakage current is measured with the pin configured as an input or as an I/O with the output driver tri-stated. It is not measured with the output driver active. Bus maintenance circuits are disabled.
2. T_A 25 °C, f = 1.0 MHz.
3. Refer to V_{IL} and V_{IH} in the [sys/I/O Single-Ended DC Electrical Characteristics](#) table of this document.

4. When V_{IH} is higher than V_{CCIO} , a transient current typically of 30 ns in duration or less with a peak current of 6 mA can occur on the high-to-low transition. For true LVDS output pins in Mach-NX devices, V_{IH} must be less than or equal to V_{CCIO} .
5. With bus keeper circuit turned on.

3.9. Static Supply Current

Table 3.8. Static Supply Current^{1, 2, 3, 6}

Symbol	Parameter	Typ. ⁴	Units
I_{CC}	Core Power Supply	20	mA
I_{CCIO}	Bank Power Supply ⁵ $V_{CCIO} = 2.5$ V	10	μ A

Notes:

1. Assumes blank pattern with the following characteristics: all outputs are tri-stated, all inputs are configured as LVCMOS and held at V_{CCIO} or GND, on-chip oscillator is off, on-chip PLL is off.
2. Frequency = 0 MHz.
3. $T_j = 25$ °C, power supplies at nominal voltage.
4. Does not include pull-up/pull-down.
5. To determine the Mach-NX peak start-up current data, use the Power Calculator tool.
6. Determination of safe ambient operating conditions requires use of the Diamond Power Calculator tool.

3.10. Programming and Erase Supply Current

Table 3.9. Programming and Erase Supply Current^{1, 2, 3, 4}

Symbol	Parameter	Typ. ⁴	Units
I_{CC}	Core Power Supply	71	mA
I_{CCIO}	Bank Power Supply ⁵ $V_{CCIO} = 2.5$ V	10	μ A

Notes:

1. Assumes all inputs are held at V_{CCIO} or GND and all outputs are tri-stated.
2. Typical user pattern.
3. JTAG programming is at 25 MHz.
4. $T_j = 25$ °C, power supplies at nominal voltage.
5. Per bank. $V_{CCIO} = 2.5$ V. Does not include pull-up/pull-down.

3.11. sysI/O Recommended Operating Conditions

Table 3.10. sysI/O Recommended Operating Conditions

Standard	V _{CCIO} (V)			V _{REF} (V)		
	Min.	Typ.	Max.	Min.	Typ.	Max.
LVC MOS 3.3	3.135	3.3	3.465	—	—	—
LVC MOS 2.5	2.375	2.5	2.625	—	—	—
LVC MOS 1.8	1.71	1.8	1.89	—	—	—
LVC MOS 1.5	1.425	1.5	1.575	—	—	—
LVC MOS 1.2	1.14	1.2	1.26	—	—	—
LVTTL	3.135	3.3	3.465	—	—	—
LVDS25 ^{1, 2}	2.375	2.5	2.625	—	—	—
LVDS33 ^{1, 2}	3.135	3.3	3.465	—	—	—
LVPECL ¹	3.135	3.3	3.465	—	—	—
BLVDS ¹	2.375	2.5	2.625	—	—	—
LVC MOS25R33	3.135	3.3	3.465	1.1	1.25	1.4
LVC MOS18R33	3.135	3.3	3.465	0.75	0.9	1.05
LVC MOS18R25	2.375	2.5	2.625	0.75	0.9	1.05
LVC MOS15R33	3.135	3.3	3.465	0.6	0.75	0.9
LVC MOS15R25	2.375	2.5	2.625	0.6	0.75	0.9
LVC MOS12R33	3.135	3.3	3.465	0.45	0.6	0.75
LVC MOS12R25	2.375	2.5	2.625	0.45	0.6	0.75
LVC MOS10R33	3.135	3.3	3.465	0.35	0.5	0.65
LVC MOS10R25	2.375	2.5	2.625	0.35	0.5	0.65

Notes:

1. Inputs on-chip. Outputs are implemented with the addition of external resistors.
2. For the dedicated LVDS buffers.

3.12. sysI/O Single-Ended DC Electrical Characteristics

Table 3.11. sysI/O Single-Ended DC Electrical Characteristics^{1,2}

Input/Output Standard	V _{IL}		V _{IH}		VOL Max. (V)	VOH Min. (V)	IOL Max. ⁴ (mA)	IOH Max. ⁴ (mA)
	Min. (V) ³	Max. (V)	Min. (V)	Max. (V)				
LVCMOS 3.3 LVTTTL	-0.3	0.8	2.0	3.6	0.4	V _{CCIO} - 0.4	4	-4
							8	-8
							12	-12
							16	-16
					0.2	V _{CCIO} - 0.2	0.1	-0.1
LVCMOS 2.5	-0.3	0.7	1.7	3.6	0.4	V _{CCIO} - 0.4	4	-4
							8	-8
							12	-12
							16	-16
					0.2	V _{CCIO} - 0.2	0.1	-0.1
LVCMOS 1.8	-0.3	0.35 V _{CCIO}	0.65 V _{CCIO}	3.6	0.4	V _{CCIO} - 0.4	4	-4
							8	-8
							12	-12
							16	-16
					0.2	V _{CCIO} - 0.2	0.1	-0.1
LVCMOS 1.5	-0.3	0.35 V _{CCIO}	0.65 V _{CCIO}	3.6	0.4	V _{CCIO} - 0.4	4	-4
							8	-8
							12	-12
							16	-16
					0.2	V _{CCIO} - 0.2	0.1	-0.1
LVCMOS 1.2	-0.3	0.35 V _{CCIO}	0.65 V _{CCIO}	3.6	0.4	V _{CCIO} - 0.4	4	-2
							8	-6
							12	-12
							16	-16
					0.2	V _{CCIO} - 0.2	0.1	-0.1
LVCMS25R33	-0.3	V _{REF} - 0.1	V _{REF} +0.1	3.6	NA	NA	NA	NA
LVCMS18R33	-0.3	V _{REF} - 0.1	V _{REF} +0.1	3.6	NA	NA	NA	NA
LVCMS18R25	-0.3	V _{REF} - 0.1	V _{REF} +0.1	3.6	NA	NA	NA	NA
LVCMS15R33	-0.3	V _{REF} - 0.1	V _{REF} +0.1	3.6	NA	NA	NA	NA
LVCMS15R25	-0.3	V _{REF} - 0.1	V _{REF} +0.1	3.6	NA	NA	NA	NA
LVCMS12R33	-0.3	V _{REF} - 0.1	V _{REF} +0.1	3.6	0.40	NA	24, 16, 12, 8, 4	NA
LVCMS12R25	-0.3	V _{REF} - 0.1	V _{REF} +0.1	3.6	0.40	NA	16, 12, 8, 4	NA
LVCMS10R33	-0.3	V _{REF} - 0.1	V _{REF} +0.1	3.6	0.40	NA	24, 16, 12, 8, 4	NA
LVCMS10R25	-0.3	V _{REF} - 0.1	V _{REF} +0.1	3.6	0.40	NA	16, 12, 8, 4	NA

Notes:

1. Mach-NX devices allow LVCMOS inputs to be placed in I/O banks where V_{CCIO} is different from what is specified in the applicable JEDEC specification. This is referred to as a ratioed input buffer. In a majority of cases, this operation follows or exceeds the applicable JEDEC specification.
2. Mach-NX devices allow for LVCMOS referenced I/O, which follow applicable JEDEC specifications.
3. The dual function I²C pins SCL and SDA are limited to a V_{IL} min of -0.25 V or to -0.3 V with a duration of <10 ns.
4. For electromigration, the average DC current sourced or sunk by I/O pads between two consecutive V_{CCIO} or GND pad connections, or between the last V_{CCIO} or GND in an I/O bank and the end of an I/O bank, as shown in the Logic Signal Connections table (also shown as I/O grouping) shall not exceed a maximum of n * 8 mA. "n" is the number of I/O pads between the two consecutive bank V_{CCIO} or GND connections or between the last V_{CCIO} and GND in a bank and the end of a bank. I/O Grouping can be found in the Data Sheet Pin Tables, which can also be generated from the Lattice Diamond software.

3.13. sysI/O Differential Electrical Characteristics

The LVDS differential output buffers are available on the top side of the Mach-NX FPGA family.

3.13.1. LVDS

Over Recommended Operating Conditions.

Table 3.12. LVDS

Parameter Symbol	Parameter Description	Test Conditions	Min.	Typ.	Max.	Units
V_{INP}, V_{INM}	Input Voltage	$V_{CCIO} = 3.3\text{ V}$	0	—	2.6	V
		$V_{CCIO} = 2.5\text{ V}$	0	—	2.0	V
V_{THD}	Differential Input Threshold	—	± 100	—		mV
V_{CM}	Input Common Mode Voltage	$V_{CCIO} = 3.3\text{ V}$	0.05	—	2.6	V
		$V_{CCIO} = 2.5\text{ V}$	0.05	—	2.0	V
I_{IN}	Input current	Power on	—	—	± 10	μA
V_{OH}	Output high voltage for V_{OP} or V_{OM}	$R_T = 100\ \Omega$	—	1.375	—	V
V_{OL}	Output low voltage for V_{OP} or V_{OM}	$R_T = 100\ \Omega$	0.9	1.025	—	V
V_{OD}	Output voltage differential	$(V_{OP} - V_{OM}), R_T = 100\ \Omega$	250	350	450	mV
ΔV_{OD}	Change in V_{OD} between high and low	—	—	—	50	mV
V_{OS}	Output voltage offset	$(V_{OP} - V_{OM})/2, R_T = 100\ \Omega$	1.1	1.20	1.395	V
ΔV_{OS}	Change in V_{OS} between H and L	—	—	—	50	mV
I_{OSD}	Output short circuit current	$V_{OD} = 0\text{ V}$ driver outputs shorted	—	—	24	mA

3.13.2. LVDS Emulation

Mach-NX devices can support LVDS outputs via emulation (LVDS25E). The output is emulated using complementary LVCMOS outputs in conjunction with resistors across the driver outputs. The scheme shown in Figure 3.1 is one possible solution for LVDS standard implementation. Resistor values in Figure 3.1 are industry standard values for 1% resistors.

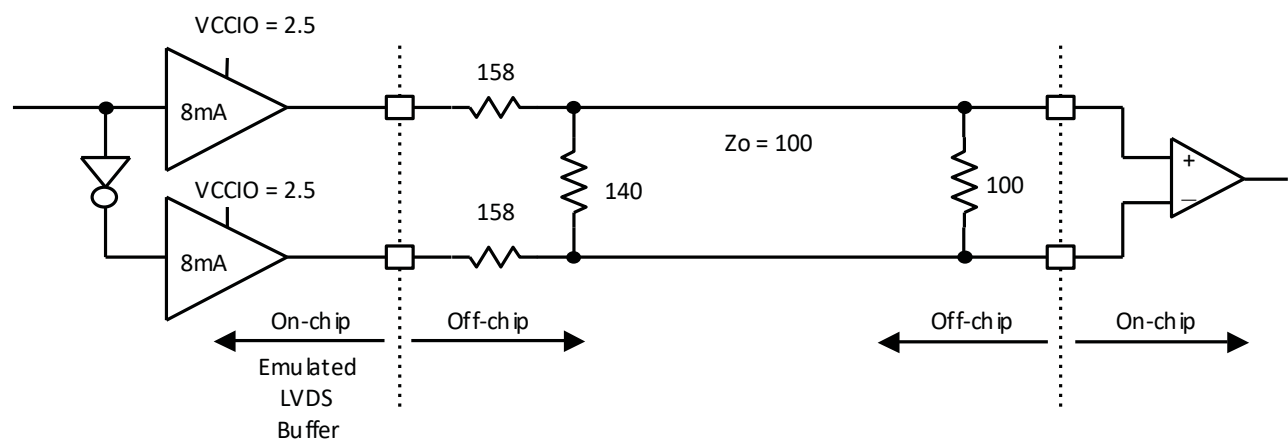

Note: All resistors are $\pm 1\%$.

Figure 3.1. LVDS Using External Resistors (LVDS25E)

3.13.3. LVDS25E DC Conditions

Over Recommended Operating Conditions

Table 3.13. LVDS25E DC Conditions

Parameter	Description	Typ.	Units
Z _{OUT}	Output impedance	20	Ω
R _S	Driver series resistor	158	Ω
R _P	Driver parallel resistor	140	Ω
R _T	Receiver termination	100	Ω
V _{OH}	Output high voltage	1.43	V
V _{OL}	Output low voltage	1.07	V
V _{OD}	Output differential voltage	0.35	V
V _{CM}	Output common mode voltage	1.25	V
Z _{BACK}	Back impedance	100	Ω
I _{DC}	DC output current	6.03	mA

3.13.4. BLVDS

The Mach-NX family supports the BLVDS standard through emulation. The output is emulated using complementary LVCMOS outputs in conjunction with resistors across the driver outputs. The input standard is supported by the LVDS differential input buffer. BLVDS is intended for use when multi-drop and bi-directional multi-point differential signaling is required. The scheme shown in [Figure 3.2](#) is one possible solution for bi-directional multi-point differential signals.

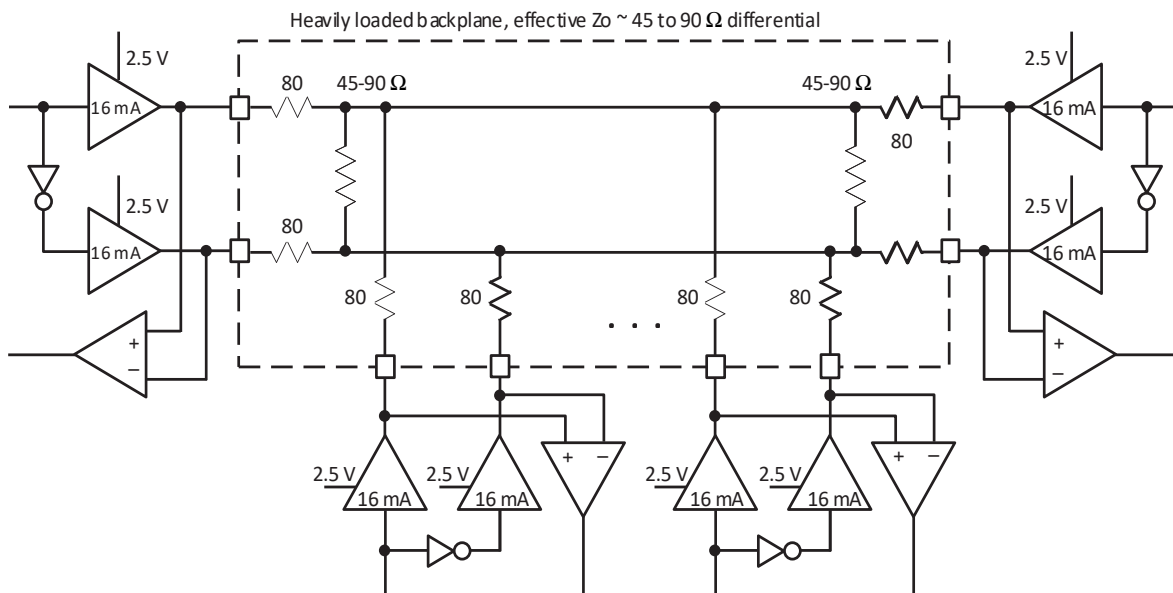

Figure 3.2. BLVDS Multi-point-Output Example

3.13.5. BLVDS DC Condition

Over Recommend Operating Conditions

Table 3.14. BLVDS DC Conditions

Symbol	Description	Nominal		Units
		Z _o = 45	Z _o = 90	
Z _{OUT}	Output impedance	20	20	Ω

Symbol	Description	Nominal		Units
		Zo = 45	Zo = 90	
R _S	Driver series resistance	80	80	Ω
R _{TLEFT}	Left end termination	45	90	Ω
R _{TRIGHT}	Right end termination	45	90	Ω
V _{OH}	Output high voltage	1.375	1.480	V
V _{OL}	Output low voltage	1.125	1.020	V
V _{OD}	Output differential voltage	0.25	0.46	V
V _{CM}	Output common mode voltage	1.250	1.250	V
I _{DC}	DC output current	11.24	10.20	mA

Note: For input buffer, see [Table 3.12](#).

3.13.6. LVPECL

The Mach-NX family supports the differential LVPECL standard through emulation. This output standard is emulated using complementary LVCMOS outputs in conjunction with resistors across the driver outputs on all the devices. The LVPECL input standard is supported by the LVDS differential input buffer. The scheme shown in Differential LVPECL is one possible solution for point-to-point signals.

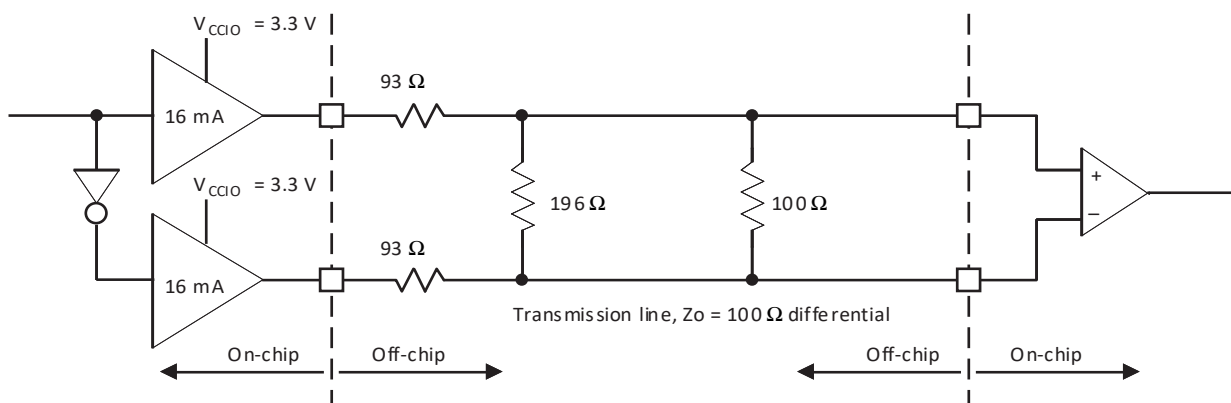

Figure 3.3. Differential LVPECL

3.13.7. LVPECL DC Conditions

Over Recommended Operating Conditions

Table 3.15. LVPECL DC Conditions

Symbol	Description	Nominal	Units
Z _{OUT}	Output impedance	20	Ω
R _S	Driver series resistor	93	Ω
R _P	Driver parallel resistor	196	Ω
R _T	Receiver termination	100	Ω
V _{OH}	Output high voltage	2.05	V
V _{OL}	Output low voltage	1.25	V
V _{OD}	Output differential voltage	0.80	V
V _{CM}	Output common mode voltage	1.65	V
Z _{BACK}	Back impedance	100	Ω
I _{DC}	DC output current	12.11	mA

Note: For input buffer, see [Table 3.12](#).

For further information on LVPECL, BLVDS and other differential interfaces, see details of additional technical documentation at the end of the data sheet.

3.13.8. MIPI D-PHY Emulation

Mach-NX devices can support MIPI D-PHY unidirectional High Speed (HS) and bidirectional Low Power (LP) inputs and outputs via emulation. In conjunction with external resistors, High Speed I/O use the LVDS25E buffer and Low Power I/O use the LVCMOS buffers. The scheme shown in [Figure 3.4](#) is one possible solution for MIPI D-PHY Receiver implementation. The scheme shown in [Figure 3.5](#) is one possible solution for MIPI D-PHY Transmitter implementation.

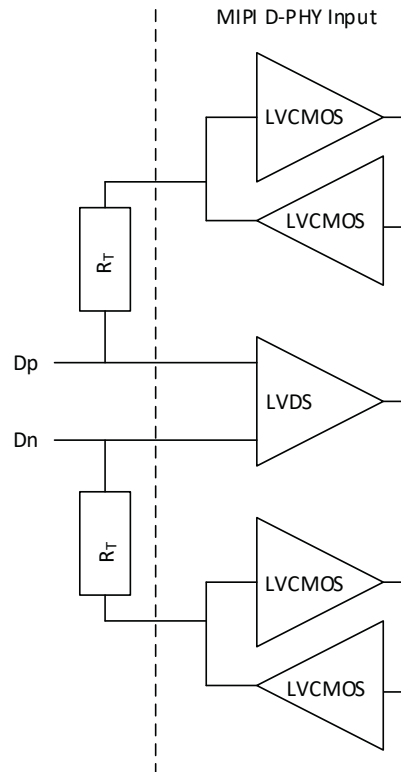

Figure 3.4. MIPI D-PHY Input Using External Resistors

Over recommended operating conditions.

Table 3.16. MIPI DC Conditions

Symbol	Description	Min.	Typ.	Max.	Units
Receiver					
External Termination					
R _T	1% external resistor with V _{CCIO} =2.5 V	—	50	—	Ω
	1% external resistor with V _{CCIO} =3.3 V	—	50	—	Ω
High Speed					
V _{CCIO}	V _{CCIO} of the Bank with LVDS Emulated input buffer	—	2.5	—	V
	V _{CCIO} of the Bank with LVDS Emulated input buffer	—	3.3	—	V
V _{CMRX}	Common-mode voltage HS receive mode	150	200	250	mV
V _{IDTH}	Differential input high threshold	—	—	100	mV
V _{IDTL}	Differential input low threshold	-100	—	—	mV
V _{IHHS}	Single-ended input high voltage	—	—	300	mV
V _{ILHS}	Single-ended input low voltage	100	—	—	mV
Z _{ID}	Differential input impedance	80	100	120	Ω
Low Power					
V _{CCIO}	V _{CCIO} of the Bank with LVCMOS12D 6 mA drive bidirectional I/O buffer	—	1.2	—	V
V _{IH}	Logic 1 input voltage	—	—	0.88	V
V _{IL}	Logic 0 input voltage, not in ULP State	0.55	—	—	V
V _{HYST}	Input hysteresis	25	—	—	mV

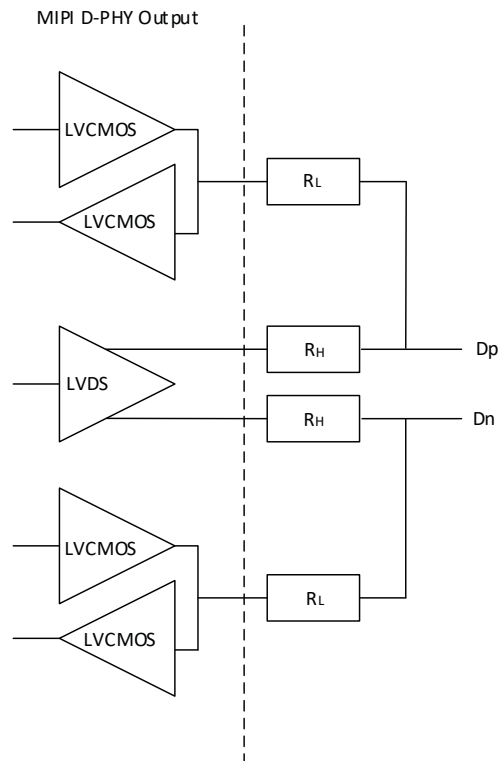

Figure 3.5. MIPI D-PHY Output Using External Resistors

Over recommended operating conditions.

Table 3.17. MIPI D-PHY Output DC Conditions

Symbol	Description	Min.	Typ.	Max.	Units
Transmitter					
External Termination					
R _L	1% external resistor with V _{CCIO} = 2.5 V	—	50	—	Ω
	1% external resistor with V _{CCIO} = 3.3 V	—	50	—	
R _H	1% external resistor with performance up to 800 Mbps or with performance up 900 Mbps when V _{CCIO} = 2.5 V	—	330	—	Ω
	1% external resistor with performance between 800 Mbps to 900 Mbps when V _{CCIO} = 3.3 V	—	464	—	Ω
High Speed					
V _{CCIO}	V _{CCIO} of the Bank with LVDS Emulated output buffer	—	2.5	—	V
	V _{CCIO} of the Bank with LVDS Emulated output buffer	—	3.3	—	V
V _{CMTX}	HS transmit static common mode voltage	150	200	250	mV
V _{OD}	HS transmit differential voltage	140	200	270	mV
V _{OHHS}	HS output high voltage	—	—	360	V
Z _{OS}	Single ended output impedance	—	50	—	Ω
ΔZ _{OS}	Single ended output impedance mismatch	—	—	10	%
Low Power					
V _{CCIO}	V _{CCIO} of the Bank with LVCMOS12D 6 mA drive bidirectional I/O buffer	—	1.2	—	V
V _{OH}	Output high level	1.1	1.2	1.3	V
V _{OL}	Output low level	-50	0	50	mV
Z _{OLP}	Output impedance of LP transmitter	110	—	—	Ω

3.14. Typical Building Block Function Performance

3.14.1. Pin-to-Pin Performance (LVCMOS25 12 mA Drive)

Table 3.18. Pin-to-Pin Performance (LVCMOS25 12 mA Drive)

Function	-5 Timing	Units
Basic Functions		
16-bit decoder	—	ns
4:1 MUX	—	ns
16:1 MUX	—	ns

3.14.2. Register-to-Register Performance

Table 3.19. Register-to-Register Performance

Function	-5 Timing	Units
Basic Functions		
16:1 MUX	—	MHz
16-bit adder	—	MHz
16-bit counter	—	MHz
64-bit counter	—	MHz
Embedded Memory Functions		
1024x9 True-Dual Port RAM (Write Through or Normal, EBR output registers)	—	MHz
Distributed Memory Functions		
16x4 Pseudo-Dual Port RAM (one PFU)	—	MHz

Note: The above timing numbers in [Table 3.18](#) and [Table 3.19](#) are generated using the Diamond design tool. Exact performance may vary with device and tool version. The tool uses internal parameters that are characterized over process, voltage, and temperature, but are not tested on every device. Commercial timing numbers are shown at 85 °C and 1.14 V. Other operating conditions, including industrial, can be extracted from the Diamond software.

3.15. Derating Logic Timing

Logic timing provided in the following sections of the data sheet and the Lattice design tools are worst case numbers in the operating range. Actual delays may be much faster. Lattice design tools can provide logic timing numbers at a particular temperature and voltage.

3.16. Maximum sysI/O Buffer Performance

Table 3.20. Maximum sysI/O Buffer Performance

I/O Standard	Maximum Speed	Units
MIPI	450	MHz
LVDS25	400	MHz
LVDS25E	150	MHz
BLVDS25	150	MHz
BLVDS25E	150	MHz
MLVDS25	150	MHz
MLVDS25E	150	MHz
LVPECL33	150	MHz
LVPECL33E	150	MHz
LVTTTL33	150	MHz
LVTTTL33D	150	MHz
LVC MOS33	150	MHz
LVC MOS33D	150	MHz
LVC MOS25	150	MHz
LVC MOS25D	150	MHz
LVC MOS18	150	MHz
LVC MOS18D	150	MHz
LVC MOS15	150	MHz
LVC MOS15D	150	MHz
LVC MOS12	91	MHz
LVC MOS12D	91	MHz

3.17. Mach-NX External Switching Characteristics – HC Devices

Over Recommended Operating Conditions.

Table 3.21. Mach-NX External Switching Characteristics – HC Devices^{1, 2, 3, 4, 5, 6, 10}

Parameter	Description	Device	–5		Units
			Min.	Max.	
Clocks					
Primary Clocks					
f _{MAX_PRI} ⁷	Frequency for Primary Clock Tree	LFMNX-50	—	320	MHz
t _{W_PRI}	Clock Pulse Width for Primary Clock	LFMNX-50	0.6	—	ns
t _{SKEW_PRI}	Primary Clock Skew Within a Device	LFMNX-50	—	—	—
		LFMNX-50	—	1432	ps
Edge Clock					
f _{MAX_EDGE} ⁷	Frequency for Edge Clock	LFMNX-50	—	333	MHz
Pin-LUT-Pin Propagation Delay					
t _{PD}	Best case propagation delay through one LUT-4	LFMNX-50	—	7.00	ns
General I/O Pin Parameters (Using Primary Clock without PLL)					
t _{CO}	Clock to Output – PIO Output Register	LFMNX-50	—	7.83	ns
t _{SU}	Clock to Data Setup – PIO Input Register	LFMNX-50	–0.24	—	ns
t _H	Clock to Data Hold – PIO Input Register	LFMNX-50	2.24	—	ns
t _{SU_DEL}	Clock to Data Setup – PIO Input Register with Data Input Delay	LFMNX-50	1.80	—	ns
t _{H_DEL}	Clock to Data Hold – PIO Input Register with Input Data Delay	LFMNX-50	–0.24	—	ns
f _{MAX_IO}	Clock Frequency of I/O and PFU Register	LFMNX-50	—	320	MHz
General I/O Pin Parameters (Using Edge Clock without PLL)					
T _{COE}	Clock to Output – PIO Output Register	LFMNX-50	—	9.35	ns
t _{SUE}	Clock to Data Setup – PIO Input Register	LFMNX-50	–0.20	—	ns
t _{HE}	Clock to Data Hold – PIO Input Register	LFMNX-50	2.25	—	ns
t _{SU_DELE}	Clock to Data Setup – PIO Input Register with Data Input Delay	LFMNX-50	1.85	—	ns
t _{H_DELE}	Clock to Data Hold – PIO Input Register with Input Data Delay	LFMNX-50	–0.30	—	ns
General I/O Pin Parameters (Using Primary Clock with PLL)					
t _{COPLL}	Clock to Output – PIO Output Register	LFMNX-50	—	6.13	ns
t _{SUPLL}	Clock to Data Setup – PIO Input Register	LFMNX-50	0.33	—	ns
t _{HPLL}	Clock to Data Hold – PIO Input Register	LFMNX-50	0.55	—	ns
t _{SU_DELPLL}	Clock to Data Setup – PIO Input Register with Data Input Delay	LFMNX-50	3.37	—	ns
t _{H_DELPLL}	Clock to Data Hold – PIO Input Register with Input Data Delay	LFMNX-50	–0.93	—	ns

Parameter	Description	Device	-5		Units
			Min.	Max.	
Generic DDRX1 Inputs with Clock and Data Aligned at Pin Using PCLK Pin for Clock Input – GDDRX1_RX.SCLK.Aligned^{8,9,13}					
t _{DVA}	Input Data Valid After CLK	All Mach-NX Devices, all sides	—	0.344	UI
t _{DVE}	Input Data Hold After CLK		0.702	—	UI
f _{DATA}	DDRX1 Input Data Speed		—	250	Mbps
f _{DDRX1}	DDRX1 SCLK Frequency		—	125	MHz
Generic DDRX1 Inputs with Clock and Data Centered at Pin Using PCLK Pin for Clock Input – GDDRX1_RX.SCLK.Centered^{8,9,13}					
t _{SU}	Input Data Setup Before CLK	All Mach-NX Devices, all sides	0.560	—	ns
t _{HO}	Input Data Hold After CLK		0.879	—	ns
f _{DATA}	DDRX1 Input Data Speed		—	250	Mbps
f _{DDRX1}	DDRX1 SCLK Frequency		—	125	MHz
Generic DDRX2 Inputs with Clock and Data Aligned at Pin Using PCLK Pin for Clock Input – GDDRX2_RX.ECLK.Aligned^{8,9}					
t _{DVA}	Input Data Valid After CLK	Mach-NX devices, bottom side only	—	0.342	UI
t _{DVE}	Input Data Hold After CLK		0.675	—	UI
f _{DATA}	DDRX2 Serial Input Data Speed		—	554	Mbps
f _{DDRX2}	DDRX2 ECLK Frequency		—	277	MHz
f _{SCLK}	SCLK Frequency		—	139	MHz
Generic DDRX2 Inputs with Clock and Data Centered at Pin Using PCLK Pin for Clock Input – GDDRX2_RX.ECLK.Centered^{8,9}					
t _{SU}	Input Data Setup Before CLK	Mach-NX devices, bottom side only	0.233	—	ns
t _{HO}	Input Data Hold After CLK		0.287	—	ns
f _{DATA}	DDRX2 Serial Input Data Speed		—	554	Mbps
f _{DDRX2}	DDRX2 ECLK Frequency		—	277	MHz
f _{SCLK}	SCLK Frequency		—	139	MHz
Generic DDR4 Inputs with Clock and Data Aligned at Pin Using PCLK Pin for Clock Input – GDDR4_RX.ECLK.Aligned⁸					
t _{DVA}	Input Data Valid After ECLK	Mach-NX devices, bottom side only	—	0.320	UI
t _{DVE}	Input Data Hold After ECLK		0.699	—	UI
f _{DATA}	DDR4 Serial Input Data Speed		—	630	Mbps
f _{DDR4}	DDR4 ECLK Frequency		—	315	MHz
f _{SCLK}	SCLK Frequency		—	79	MHz
Generic DDR4 Inputs with Clock and Data Centered at Pin Using PCLK Pin for Clock Input – GDDR4_RX.ECLK.Centered⁸					
t _{SU}	Input Data Setup Before ECLK	Mach-NX devices, bottom side only	0.233	—	ns
t _{HO}	Input Data Hold After ECLK		0.287	—	ns
f _{DATA}	DDR4 Serial Input Data Speed		—	630	Mbps
f _{DDR4}	DDR4 ECLK Frequency		—	315	MHz
f _{SCLK}	SCLK Frequency		—	79	MHz
7:1 LVDS Inputs (GDDR71_RX.ECLK.7:1)⁹					
t _{DVA}	Input Data Valid After ECLK (See Figure 3.6)	Mach-NX devices, bottom side only	—	0.320	UI
t _{DVE}	Input Data Hold After ECLK (See Figure 3.6)		0.699	—	UI
f _{DATA}	DDR71 Serial Input Data Speed		—	630	Mbps
f _{DDR71}	DDR71 ECLK Frequency		—	315	MHz
f _{CLKIN}	7:1 Input Clock Frequency (SCLK) (minimum limited by PLL)		—	90	MHz

Parameter	Description	Device	-5		Units
			Min.	Max.	
MIPI D-PHY Inputs with Clock and Data Centered at Pin Using PCLK Pin for Clock Input - GDDR4_RX.ECLK.Centered^{10,11,12}					
t _{SU} ¹⁶	Input Data Setup Before ECLK	All Mach-NX devices, bottom side only	0.200	—	UI
t _{HO} ¹⁶	Input Data Hold After ECLK		0.200	—	UI
f _{DATA} ¹⁵	MIPI D-PHY Input Data Speed		—	900	Mbps
f _{DDR4} ¹⁵	MIPI D-PHY ECLK Frequency		—	450	MHz
f _{SCLK} ¹⁵	SCLK Frequency		—	112.5	MHz
Generic DDR Outputs with Clock and Data Aligned at Pin Using PCLK Pin for Clock Input – GDDR1_TX.SCLK.Aligned^{8,13}					
t _{DIA}	Output Data Invalid After CLK Output	All Mach-NX devices, all sides	—	0.55	ns
t _{DIB}	Output Data Invalid Before CLK Output		—	0.55	ns
f _{DATA}	DDR1 Output Data Speed		—	250	Mbps
f _{DDR1}	DDR1 SCLK frequency		—	125	MHz
Generic DDR Outputs with Clock and Data Centered at Pin Using PCLK Pin for Clock Input – GDDR1_TX.SCLK.Centered^{8,13}					
t _{DVB}	Output Data Valid Before CLK Output	All Mach-NX devices, all sides	1.510	—	ns
t _{DVA}	Output Data Valid After CLK Output		1.510	—	ns
f _{DATA}	DDR1 Output Data Speed		—	250	Mbps
f _{DDR1}	DDR1 SCLK Frequency (minimum limited by PLL)		—	125	MHz
Generic DDR2 Outputs with Clock and Data Aligned at Pin Using PCLK Pin for Clock Input – GDDR2_TX.ECLK.Aligned⁸					
t _{DIA}	Output Data Invalid After CLK Output	Mach-NX devices, top side only	—	0.215	ns
t _{DIB}	Output Data Invalid Before CLK Output		—	0.215	ns
f _{DATA}	DDR2 Serial Output Data Speed		—	554	Mbps
f _{DDR2}	DDR2 ECLK frequency		—	277	MHz
f _{SCLK}	SCLK Frequency		—	139	MHz
Generic DDR2 Outputs with Clock and Data Centered at Pin Using PCLK Pin for Clock Input – GDDR2_TX.ECLK.Centered^{8,9}					
t _{DVB}	Output Data Valid Before CLK Output	Mach-NX devices, top side only	0.670	—	ns
t _{DVA}	Output Data Valid After CLK Output		0.670	—	ns
f _{DATA}	DDR2 Serial Output Data Speed		—	554	Mbps
f _{DDR2}	DDR2 ECLK Frequency (minimum limited by PLL)		—	277	MHz
f _{SCLK}	SCLK Frequency		—	139	MHz
Generic DDR4 Outputs with Clock and Data Centered at Pin Using PCLK Pin for Clock Input – GDDR4_TX.ECLK.Centered^{8,9}					
t _{DIA}	Output Data Invalid After CLK Output	Mach-NX devices, top side only	—	0.215	ns
t _{DIB}	Output Data Invalid Before CLK Output		—	0.215	ns
f _{DATA}	DDR4 Serial Output Data Speed		—	630	Mbps
f _{DDR4}	DDR4 ECLK Frequency		—	315	MHz
f _{SCLK}	SCLK Frequency		—	79	MHz

Parameter	Description	Device	-5		Units
			Min.	Max.	
Generic DDRX4 Outputs with Clock and Data Centered at Pin Using PCLK Pin for Clock Input – GDDR4_TX.ECLK.Centered^{8,9}					
t _{DVB}	Output Data Valid Before CLK Output	Mach-NX devices, top side only	0.570	—	ns
t _{DVA}	Output Data Valid After CLK Output		0.570	—	ns
f _{DATA}	DDR4 Serial Output Data Speed		—	630	Mbps
f _{DDR4}	DDR4 ECLK Frequency (minimum limited by PLL)		—	315	MHz
f _{SCLK}	SCLK Frequency		—	79	MHz
7:1 LVDS Outputs – GDDR71_TX.ECLK.7:1^{8,9}					
t _{DIB}	Output Data Invalid Before CLK Output (See Figure 3.7)	Mach-NX devices, top side only	—	0.180	ns
t _{DIA}	Output Data Invalid After CLK Output (See Figure 3.7)		—	0.180	ns
f _{DATA}	DDR71 Serial Output Data Speed		—	630	Mbps
f _{DDR71}	DDR71 ECLK Frequency		—	315	MHz
f _{CLKOUT}	7:1 Output Clock Frequency (SCLK) (minimum limited by PLL)		—	90	MHz
MIPI D-PHY Outputs with Clock and Data Centered at Pin Using PCLK Pin for Clock Input – GDDR4_TX.ECLK.Centered^{10,11,12}					
t _{DVB}	Output Data Valid Before CLK Output	All Mach-NX devices, top side only	0.200	—	UI
t _{DVA}	Output Data Valid After CLK Output		0.200	—	UI
f _{DATA}	MIPI D-PHY Output Data Speed		—	900	Mbps
f _{DDR4}	MIPI D-PHY ECLK Frequency (minimum limited by PLL)		—	450	MHz
f _{SCLK}	SCLK Frequency		—	112.5	MHz

Notes:

- Exact performance may vary with device and design implementation. Commercial timing numbers are shown at 85°C and 1.14 V. Other operating conditions, including industrial, can be extracted from the Lattice Diamond software.
- General I/O timing numbers based on LVCMOS 2.5, 8 mA, 0pf load, fast slew rate.
- Generic DDR timing numbers based on LVDS I/O (for input, output, and clock ports).
- 7:1 LVDS (GDDR71) uses the LVDS I/O standard (for input, output, and clock ports).
- For Generic DDRX1 mode t_{SU} = t_{HO} = (t_{DVE} - t_{DVA} - 0.03 ns)/2.
- The t_{SU_DEL} and t_{H_DEL} values use the SCLK_ZERHOLD default step size. Each step is 105 ps (-6), 113 ps (-5).
- This number for general purpose usage. Duty cycle tolerance is +/-10%.
- Duty cycle is +/- 5% for system usage.
- Performance is calculated with 0.225 UI.
- Performance is calculated with 0.20 UI.
- Performance for Industrial devices are only supported with VCC between 1.16 V to 1.24 V.
- Performance for Industrial devices and -5 devices are not modeled in the Diamond design tool.
- GDDR1 is not recommended to mix top banks with other banks in applications. Or, the related clock skew is increased significantly.
- The above timing numbers are generated using the Diamond design tool. Exact performance may vary with the device selected.
- Above 800 Mbps is only supported with fcCSP and fcBGA packages.
- Between 800 Mbps to 900 Mbps:
 - V_{IDTH} exceeds the MIPI D-PHY Input DC Conditions (Table 3.16) and can be calculated with the equation t_{SU} or t_H = -0.0005*V_{IDTH} + 0.3284
 - Example calculations
 - t_{SU} and t_{HO} = 0.28 with V_{IDTH} = 100 mV
 - t_{SU} and t_{HO} = 0.24 with V_{IDTH} = 170 mV
 - t_{SU} and t_{HO} = 0.19 with V_{IDTH} = 270 mV

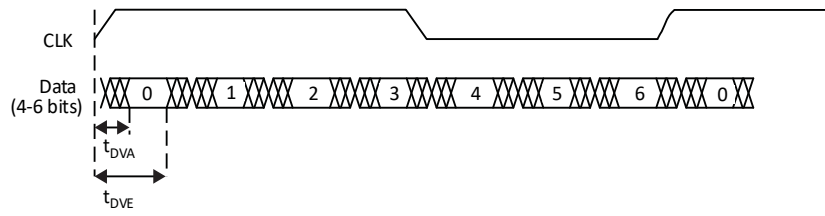

Figure 3.6. Receiver GDDR71_RX. Waveforms

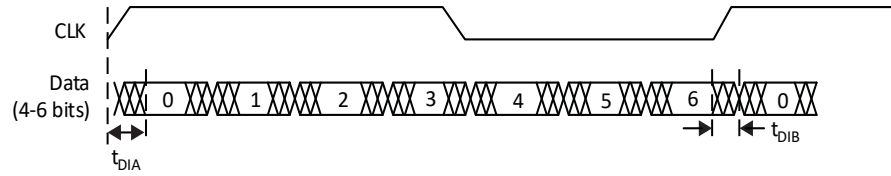

Figure 3.7. Transmitter GDDR71_TX. Waveforms

3.18. sysCLOCK PLL Timing

Over Recommended Operating Conditions.

Table 3.22. sysCLOCK PLL Timing

Parameter	Descriptions	Conditions	Min.	Max.	Units
f _{IN}	Input Clock Frequency (CLKI, CLKFB)	—	7	400	MHz
f _{OUT}	Output Clock Frequency (CLKOP, CLKOS, CLKOS2)	—	1.5625	400	MHz
f _{OUT2}	Output Frequency (CLKOS3 cascaded from CLKOS2)	—	0.0122	400	MHz
f _{VCO}	PLL VCO Frequency	—	200	800	MHz
f _{PFD}	Phase Detector Input Frequency	—	7	400	MHz
AC Characteristics					
t _{DT}	Output Clock Duty Cycle	Without duty trim selected ³	40	60	%
t _{DT_TRIM} ⁷	Edge Duty Trim Accuracy	—	-75	75	%
t _{PH} ⁴	Output Phase Accuracy	—	-6	6	%
t _{OPJIT} ^{1,8}	Output Clock Period Jitter	f _{OUT} > 100 MHz	—	210	ps p-p
		f _{OUT} < 100 MHz	—	0.008	UIPP
	Output Clock Cycle-to-cycle Jitter	f _{OUT} > 100 MHz	—	390	ps p-p
		f _{OUT} < 100 MHz	—	0.01	UIPP
	Output Clock Phase Jitter	f _{PFD} > 100 MHz	—	160	ps p-p
		f _{PFD} < 100 MHz	—	0.011	UIPP
	Output Clock Period Jitter (Fractional-N)	f _{OUT} > 100 MHz	—	320	ps p-p
		f _{OUT} < 100 MHz	—	0.38	UIPP
Output Clock Cycle-to-cycle Jitter (Fractional-N)	f _{OUT} > 100 MHz	—	270	ps p-p	
	f _{OUT} < 100 MHz	—	0.44	UIPP	
t _w	Output Clock Pulse Width	At 90% or 10% ³	0.9	—	ns
t _{LOCK} ^{2,5}	PLL Lock-in Time	—	—	15	ms
t _{UNLOCK}	PLL Unlock Time	—	—	50	ns
t _{IPJIT} ⁶	Input Clock Period Jitter	f _{PFD} ≥ 20 MHz	—	1,000	ps p-p
		f _{PFD} < 20 MHz	—	0.02	UIPP
t _{HI}	Input Clock High Time	90% to 90%	0.75	—	ns
t _{LO}	Input Clock Low Time	10% to 10%	0.75	—	ns
t _{STABLE} ⁵	STANDBY High to PLL Stable	—	—	15	ms
t _{RST}	RST/RESETM Pulse Width	—	1	—	ns
t _{RSTREC}	RST Recovery Time	—	3.1	—	ns
t _{RST_DIV}	RESETC/D Pulse Width	—	10	—	ns
t _{RSTREC_DIV}	RESETC/D Recovery Time	—	3	—	ns
t _{ROTATE-SETUP}	PHASESTEP Setup Time	—	4	—	ns
t _{ROTATE_WD}	PHASESTEP Pulse Width	—	10	—	VCO Cycles

Notes:

1. Period jitter sample is taken over 10,000 samples of the primary PLL output with a clean reference clock. Cycle-to-cycle jitter is taken over 1000 cycles. Phase jitter is taken over 2000 cycles. All values per JESD65B.
2. Output clock is valid after t_{LOCK} for PLL reset and dynamic delay adjustment.
3. Using LVDS output buffers.
4. CLKOS as compared to CLKOP output for one phase step at the maximum VCO frequency. See [Mach-NX sysCLOCK PLL Design and Usage Guide \(FPGA-TN-02215\)](#) for more details.
5. At minimum f_{PFD}. As the f_{PFD} increases, the time decreases to approximately 60% the value listed.

6. Maximum allowed jitter on an input clock. PLL unlock may occur if the input jitter exceeds this specification. Jitter on the input clock may be transferred to the output clocks, resulting in jitter measurements outside the output specifications listed in this table.
7. Edge Duty Trim Accuracy is a percentage of the setting value. Settings available are 70 ps, 140 ps, and 280 ps in addition to the default value of none.
8. Jitter values measured with the internal oscillator operating. The jitter values increase with loading of the FPGA fabric and in the presence of SSO noise.

3.19. Flash Download Time

Table 3.23. Flash Download Time

Symbol	Parameter	Device	Typ.	Units
t_{REFRESH}	POR to Device I/O Active	LFMNX-50	5.2	ms

Notes:

- Assumes sysMEM EBR initialized to an all zero pattern if they are used.
- The NVCM/Flash download time is measured starting from the maximum voltage of POR trip point.
- The worst case can be up to 1.75 times the Typ value.

3.20. JTAG Port Timing Specifications

Table 3.24. JTAG Port Timing Specifications

Symbol	Parameter	Min.	Max.	Units
f_{MAX}	TCK clock frequency	—	25	MHz
t_{BTCPH}	TCK [BSCAN] clock pulse width high	20	—	ns
t_{BTCPL}	TCK [BSCAN] clock pulse width low	20	—	ns
t_{BTS}	TCK [BSCAN] setup time	10	—	ns
t_{BTH}	TCK [BSCAN] hold time	10	—	ns
t_{BTCO}	TAP controller falling edge of clock to valid output	—	10	ns
t_{BTCODIS}	TAP controller falling edge of clock to valid disable	—	12	ns
t_{BTCOEN}	TAP controller falling edge of clock to valid enable	—	12	ns
t_{BTCRS}	BSCAN test capture register setup time	8	—	ns
t_{BTCRH}	BSCAN test capture register hold time	20	—	ns
t_{BUTCO}	BSCAN test update register, falling edge of clock to valid output	—	25	ns
t_{BTUODIS}	BSCAN test update register, falling edge of clock to valid disable	—	27	ns
t_{BTUPOEN}	BSCAN test update register, falling edge of clock to valid enable	—	25	ns

3.21. sysCONFIG Port Timing Specifications

Table 3.25. sysCONFIG Port Timing Specifications

Symbol	Parameter	Min.	Max.	Units
All Configuration Modes				
t_{PRGM}	PROGRAMN low pulse accept	109	—	ns
t_{PRGMJ}	PROGRAMN low pulse rejection	—	60	ns
t_{INITL}	INITN low time	—	130	us
$t_{DPPINIT}$	PROGRAMN low to INITN low	—	150	ns
$t_{DPPDONE}$	PROGRAMN low to DONE low	—	165	ns
t_{IODISS}	PROGRAMN low to I/O disable	—	196	ns
Slave SPI				
f_{MAX}	CCLK clock frequency	—	66	MHz
t_{CCLKH}	CCLK clock pulse width high	7.5	—	ns
t_{CCLKL}	CCLK clock pulse width low	7.5	—	ns
t_{STSU}	CCLK setup time	2	—	ns
t_{STH}	CCLK hold time	0	—	ns
t_{STCO}	CCLK falling edge to valid output	—	14	ns
t_{STOZ}	CCLK falling edge to valid disable	—	12	ns
t_{STOV}	CCLK falling edge to valid enable	—	14	ns
t_{SCS}	Chip select high time	25	—	ns
t_{SCSS}	Chip select setup time	3	—	ns
t_{SCSH}	Chip select hold time	3	—	ns

3.22. I²C Port Timing Specifications

Table 3.26. I²C Port Timing Specification

Symbol	Parameter	Min.	Max.	Units
f_{MAX}	Maximum SCL clock frequency	—	400	kHz

Notes:

- Mach-NX device supports the following modes:
- Standard-mode (Sm), with a bit rate up to 100 kb/s (user and configuration mode)
- Fast-mode (Fm), with a bit rate up to 400 kb/s (user and configuration mode)
- Refer to the I²C specification for timing requirements.

3.23. SPI Port Timing Specifications

Table 3.27. SPI Port Timing Specifications

Symbol	Parameter	Min.	Max.	Units
f_{MAX}	Maximum SCK clock frequency	—	45	MHz

Note: Applies to user mode only. For configuration mode timing specifications, refer to [sysCONFIG Port Timing Specifications](#) table in this data sheet.

3.24. Switching Test Conditions

Figure 3.9 shows the output test load used for AC testing. The specific values for resistance, capacitance, voltage, and other test conditions are shown in [Table 3.28](#).

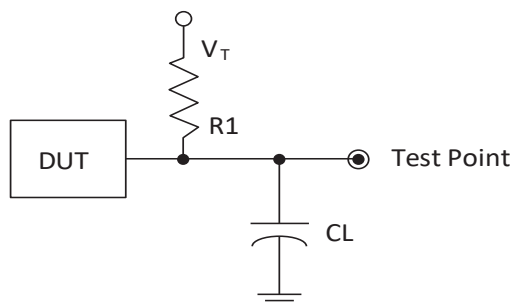

Figure 3.9. Output Test Load, LVTTTL and LVCMOS Standards

Table 3.28. Test Fixture Required Components, Non-Terminated Interfaces

Test Condition	R1	CL	Timing Ref.	VT
LVTTTL and LVCMOS settings (L -> H, H -> L)	∞	0 pF	LVTTTL, LVCMOS 3.3 = 1.5 V	—
			LVCMOS 2.5 = $V_{CCIO}/2$	—
			LVCMOS 1.8 = $V_{CCIO}/2$	—
			LVCMOS 1.5 = $V_{CCIO}/2$	—
			LVCMOS 1.2 = $V_{CCIO}/2$	—
LVTTTL and LVCMOS 3.3 (Z -> H)	188	0 pF	1.5	V_{OL}
LVTTTL and LVCMOS 3.3 (Z -> L)			1.5	V_{OH}
Other LVCMOS (Z -> H)			$V_{CCIO}/2$	V_{OL}
Other LVCMOS (Z -> L)			$V_{CCIO}/2$	V_{OH}
LVTTTL + LVCMOS (H -> Z)			$V_{OH} - 0.15$	V_{OL}
LVTTTL + LVCMOS (L -> Z)			$V_{OL} - 0.15$	V_{OH}

Note: Output test conditions for all other interfaces are determined by the respective standards.

4. Signal Descriptions

Table 4.1. Signal Descriptions

Signal Name	Bank	Type	Descriptions
General Purpose			
P[Edge] [Row/Column Number]_[A/B/C/D]	0, 1, 2	I/O	<p>[Edge] indicates the edge of the device on which the pad is located. Valid edge designations are L (Left), B (Bottom), R (Right), T (Top).</p> <p>[Row/Column Number] indicates the PFU row or the column of the device on which the PIO Group exists. When Edge is T (Top) or (Bottom), only need to specify Row Number. When Edge is L (Left) or R (Right), only need to specify Column Number.</p> <p>[A/B/C/D] indicates the PIO within the group to which the pad is connected.</p> <p>Some of these user-programmable pins are shared with special function pins. When not used as special function pins, these pins can be programmed as I/O for user logic.</p> <p>During configuration of the user-programmable I/O, you have an option to tri-state the I/O and enable an internal pull-up, pull-down or buskeeper resistor. This option also applies to unused pins (or those not bonded to a package pin). The default during configuration is for user-programmable I/O to be tri-stated with an internal pull-down resistor enabled. When the device is erased, I/O is tri-stated with an internal pull-down resistor enabled. Some pins, such as PROGRAMN and JTAG pins, default to tri-stated I/O with pull-up resistors enabled when the device is erased.</p>
NC	—	—	No internal connection.
RSRV	—	—	Reserved. Do not connect.
Power and Ground			
VSS	—	GND	Ground for internal FPGA logic and I/O.
VCC	—	Power	Power supply pins for core logic. VCC is connected to 1.0 V (nom.) supply voltage. Power-On Reset (POR) monitors this supply voltage.
VCCAUX	—	Power	Auxiliary power supply pin for internal analog circuitry. This supply is connected to 1.8 V (nom.) supply voltage. POR monitors this supply voltage.
VCCB	—	Power	Power supply for auxiliary core functions. VCCB is connected to 1.8 V (nom.) supply voltage.
VCCIOx	0-6	Power	<p>Power supply pins for I/O bank x.</p> <p>For x = 0, VCCIO can be connected to (nom.) 2.5 V, or 3.3 V.</p> <p>For x = 1, 2, 5 and 6 VCCIO can be connected to (nom.) 1.2 V, 1.5 V, 1.8 V, 2.5 V, or 3.3 V.</p> <p>For x = 3 and 4, VCCIO can be connected to (nom.) 1.0 V, 1.2 V, 1.35 V, 1.5 V, or 1.8 V.</p> <p>There are dedicated and shared configuration pins in banks 0 and 1. POR monitors these banks' supply voltages.</p>
Test and Programming (Dual function pins used for test access port and during sysCONFIG™)			
TMS	0	Input	Test Mode Select input pin, used to control the 1149.1 state machine.
TCK	0	Input	Test Clock input pin, used to clock the 1149.1 state machine.
TDI	0	Input	Test Data input pin, used to load data into the device using an 1149.1 state machine.
TDO	0	Output	Test Data output pin used to shift data out of the device using 1149.1.
JTAGEN	0	Input	<p>Optionally controls behavior of TDI, TDO, TMS, TCK. If the device is configured to use the JTAG pins (TDI, TDO, TMS, TCK) as general purpose I/O, then:</p> <p>If JTAGENB is low: TDI, TDO, TMS and TCK can function a general purpose I/O. If JTAGENB is high: TDI, TDO, TMS and TCK function as JTAG pins.</p>
Configuration (Dual function pins used during sysCONFIG)			
PROGRAMN	0	Input	Initiates configuration sequence when asserted low. This pin always has an active pull-up.
INITN	0	I/O	<p>Open Drain pin. Indicates the FPGA is ready to be configured. During configuration, a pull-up is enabled.</p> <p>Note: Available in 484 package only.</p>
DONE	0	I/O	<p>Open Drain pin. Indicates that the configuration sequence is complete, and the start-up sequence is in progress.</p> <p>Note: Available in 484 package only.</p>
CCLK	2	I/O	Input Configuration Clock for configuring an FPGA in Slave SPI mode.

Signal Name	Bank	Type	Descriptions
SN	2	Input	Slave SPI active low chip select input.
CSSPIN	2	I/O	Master SPI active low chip select output.
SI/SPISI	2	I/O	Slave SPI serial data input and master SPI serial data output.
SO/SPISO	2	I/O	Slave SPI serial data output and master SPI serial data input.
SCL	0	I/O	Slave I2C clock input and master I2C clock output.
SDA	0	I/O	Slave I2C data input and master I2C data output.
Platform Firmware Resiliency			
GPIO_xx	5,6	I/O	General Purpose I/O. xx = 0 to 23
GPIO_MMxx	3,4,6	I/O	General Purpose I/O. xx = 0 to 25
I2C_MONx_SDA	0	I/O	I2C Monitor channel x Data. x = 1,2 or 3
I2C_MONx_SCL	0	I/O	I2C Monitor channel x Clock. x = 1,2 or 3
QSPI_MONx_CLK	0,6	I/O	Quad SPI Monitor channel x CLK. x = 0, 1, or 2
QSPI_MONx_CSN	0,6	I/O	Quad SPI Monitor channel x CSN. x = 0, 1, or 2
QSPI_MONx_DQ0	0,6	I/O	Quad SPI Monitor channel x DQ0. x = 0, 1, or 2
QSPI_MONx_DQ1	0,6	I/O	Quad SPI Monitor channel x DQ1. x = 0, 1, or 2
QSPI_MONx_DQ2	0,6	I/O	Quad SPI Monitor channel x DQ2. x = 0, 1, or 2
QSPI_MONx_DQ3	0,6	I/O	Quad SPI Monitor channel x DQ3. x = 0, 1, or 2
QSPI_MONx_PRE_CSN	0,6	Input	Quad SPI Monitor channel x PRE_CSN. x = 0, 1, or 2
QSPI_MONx_SWI_EN	0,6	Output	Quad SPI Monitor channel x SWI_EN. x = 0, 1, or 2
QSPI_MONx_DIS_A	0,6	Output	Quad SPI Monitor channel x DIS_A. x = 0, 1, or 2
QSPI_MONx_DIS_B	0,6	Output	Quad SPI Monitor channel x DIS_B. x = 0, 1, or 2
QSPI_MONx_RST_O	C	Output	Quad SPI Monitor Master Reset Out. x = 0,1, or 2
QSPI_STRM_CLK	0	I/O	Secondary function: Quad SPI High Speed Authentication-only stream channel CLK
QSPI_STRM_CSN	0	I/O	Secondary function: Quad SPI High Speed Authentication-only stream channel CSN
QSPI_STRM_DQ0	0	I/O	Secondary function: Quad SPI High Speed Authentication-only stream channel DQ0
QSPI_STRM_DQ1	0	I/O	Secondary function: Quad SPI High Speed Authentication-only stream channel DQ1
QSPI_STRM_DQ2	0	I/O	Secondary function: Quad SPI High Speed Authentication-only stream channel DQ2
QSPI_STRM_DQ3	0	I/O	Secondary function: Quad SPI High Speed Authentication-only stream channel DQ3
SMBUS1_INT	5	Output	SMBus channel x Interrupt Out. x = 0 or 1
SMBUS1_SCL	5	I/O	SMBus channel x Serial Clock. x = 0 or 1
SMBUS1_SDA	5	I/O	SMBus channel x Serial Data. x = 0 or 1

4.1. Pin Information Summary

Table 4.2. LFMNX-50

	LFMNX-50	
	fcBGA484	fcCSP256
General Purpose I/O per Bank		
Bank 0	92	4
Bank 1	96	71
Bank 2	96	39
Total General Purpose Single Ended I/O	284	114
Differential I/O per Bank		
Bank 0	46	2
Bank 1	48	35
Bank 2	48	18
Total General Purpose Differential I/O	142	55
Dual Function I/O	30	16
Number 7:1 or 8:1 Gearboxes		
Number of 7:1 or 8:1 Output Gearboxes (Bank 0)	24	0
Number of 7:1 or 8:1 Input Gearboxes (Bank 2)	24	10
High-speed Differential Outputs		
Bank 0	24	0
SoC Function Block		
Dedicated SoC pins	34	34
SoC GPIO (Bank 5, 3.3V)	22	3
SoC GPIO (Bank 6, 1.8V)	2	1
SoC Memory Mapped GPIO (Bank 6, 3.3V)	10	10
SoC Memory Mapped GPIO (Bank 3-4, 1.8V)	16	16
Total SoC Function Block I/O	84	64
V_{CCIO} Pins		
Bank 0	17	6
Bank 1	6	4
Bank 2	5	2
Bank 3	1	1
Bank 4	1	1
Bank 5	2	2
Bank 6	2	2
VCC	4	3
VCCAUX	4	4
VCCB	4	5
GND	39	25
NC	0	0
RSRV	27	19
JTAG	4	4
Total Count of Bonded Pins	484	256

5. Ordering Information

5.1. Mach-NX Part Number Description

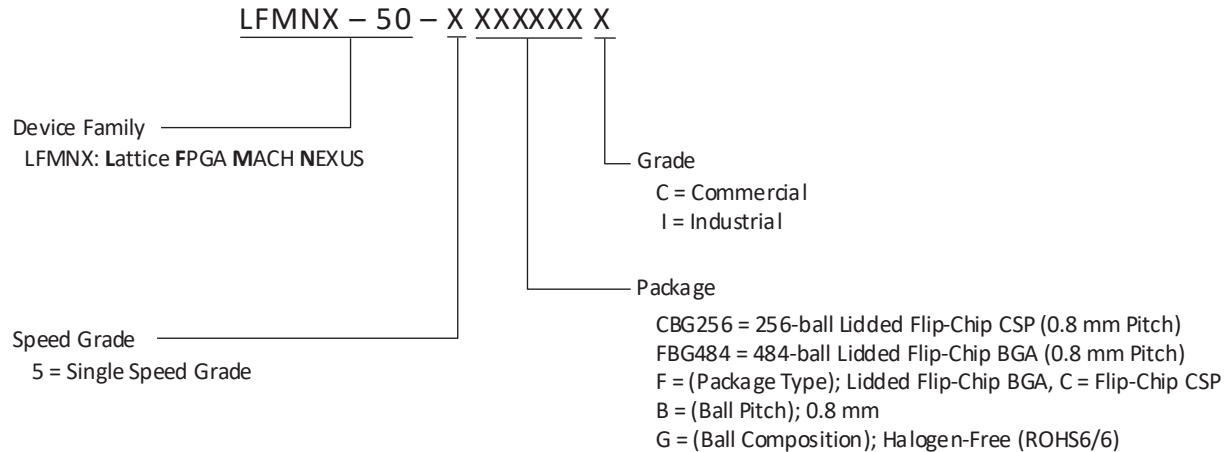

5.2. Ordering Information

Mach-NX devices have either of the top-side markings as shown in the examples below, on the 484-Ball fcBGA package with LFMNX-50 device in Commercial Temperature in Speed Grade 5.

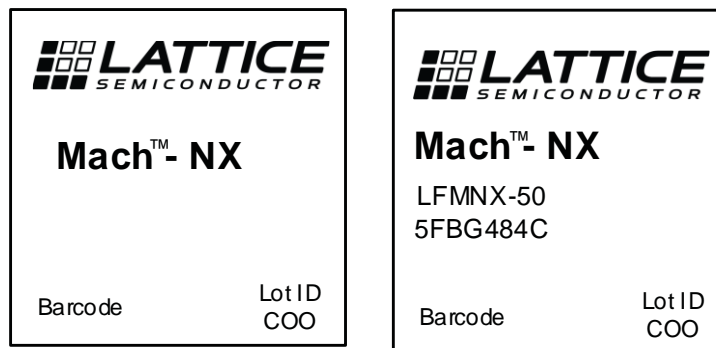

Figure 5.1. Top Marking Diagram

Note: Markings are abbreviated for small packages.

5.3. Mach-NX Low Power Commercial and Industrial Grade Devices, Halogen Free (RoHS) Packaging

Part Number	User LCs	Supply Voltage	Speed	Package	Leads	Temp.
LFMNX-50-5CBG256C	8400	2.5 V/3.3 V	5	Halogen-Free fcCSP	256	COM
LFMNX-50-5CBG256I	8400	2.5 V/3.3 V	5	Halogen-Free fcCSP	256	IND
LFMNX-50-5FBG484C	8400	2.5 V/3.3 V	5	Halogen-Free fcBGA	484	COM
LFMNX-50-5FBG484I	8400	2.5 V/3.3 V	5	Halogen-Free fcBGA	484	IND

References

A variety of technical notes for the Mach-NX family are available on the Lattice web site.

- [Mach-NX sysCLOCK PLL Design and Usage Guide \(FPGA-TN-02215\)](#)
- [Implementing High-Speed Interfaces with Mach-NX Devices Usage Guide \(FPGA-TN-02234\)](#)
- [Mach-NX sysI/O Usage Guide \(FPGA-TN-02233\)](#)
- [Mach-NX Programming and Configuration Usage Guide \(FPGA-TN-02231\)](#)
- [PCB Layout Recommendations for BGA Packages \(FPGA-TN-02024\)](#)
- [Minimizing System Interruption During Configuration Using TransFR Technology \(FPGA-TN-02198\)](#)
- [Boundary Scan Testability with Lattice sysI/O Capability \(AN8066\)](#)
- [Thermal Management document \(FPGA-TN-02044\)](#)
- [Lattice Design Tools](#)

Revision History

Revision 1.3, March 2022

Section	Change Summary
Architecture	Removed <i>eSPI Slave</i> from the Embedded Hardened IP Functions through SoC section.
Signal Descriptions	<ul style="list-style-type: none"> Table 4.1. Signal Descriptions: <ul style="list-style-type: none"> removed ESPI_ALERT, ESPI_CLK, ESPI_CS, ESPI_DATA0, ESPI_DATA1, and ESPI_RSTN signals. Table 4.2. LFMNX-50: <ul style="list-style-type: none"> updated <i>Dedicated SoC Pins</i> value to 40 for both fcBGA484 and fcCSP256; updated the <i>Total SoC Function Block I/O</i> value to 84 for fcBGA484, to 64 for fcCSP256; updated <i>RSRV</i> value to 27 for fcBGA484, to 19 for fcCSP256.

Revision 1.2, February 2022

Section	Change Summary
Signal Descriptions	Added Note <i>Available in 484 package only</i> for INITN and DONE signals in Table 4.1. Signal Descriptions .

Revision 1.1.1 and Revision 1.1.2, February 2022

Section	Change Summary
All	Special customized versions release.

Revision 1.0, January 2022

Section	Change Summary
All	<ul style="list-style-type: none"> Production Release. Changed the document title from <i>Mach-NX Device Family Data Sheet</i> to the current <i>Mach-NX Family Data Sheet</i> to align with all other data sheet naming.
Introduction	<ul style="list-style-type: none"> Changed the high I/O to LC ratio with up to 378 I/O pins in the Flexible Architecture section. Updated I/O number for both 256-ball and 484-ball packages in Table 1.1. Mach-NX Family Selection Guide.
Signal Descriptions	<ul style="list-style-type: none"> Updated the bank value for GPIO_xx and GPIO_MMxx signals in Table 4.1. Signal Descriptions. Newly added six QSPI_STRM_* signals and their related data to Table 4.1. Signal Descriptions. Global update to Table 4.2. LFMNX-50.
Ordering Information	Updated Figure 5.1. Top Marking Diagram .

Revision 0.80, December 2020

Section	Change Summary
All	Preliminary Release.

Revision 0.72, November 2020

Section	Change Summary
Features	<ul style="list-style-type: none"> Changed 369 I/O pins to 379 I/O pins in the Flexible Architecture section.
	<ul style="list-style-type: none"> Updated Table 1.1. Mach-NX Family Selection Guide: <ul style="list-style-type: none"> changing User LUTs for LFMNX-50 from 7000 to User LC for LFMNX-50 to 8400; adding Harden Security Functions; adding 256-ball caBGA package.
Mach-NX Low Power Commercial and Industrial Grade Devices, Halogen Free (RoHS) Packaging	Added two 256-ball caBGA packages.

Revision 0.71, October 2020

Section	Change Summary
All	Advance Release, Features and Signal Description.

Revision 0.70, July 2020



Section	Change Summary
All	Pre-Advance Release, Features and Signal Description only.



www.latticesemi.com

Looking for pricing, stock, or lifecycle information?

Click below to explore more details on WIN SOURCE:

-  [View LFMNX-50-5FBG484C on WIN SOURCE](#)
-  [Lattice Semiconductor Corporation](#) Information

Optimize Your Supply Chain with WIN SOURCE Solutions

-  Global Sourcing Solution
-  Obsolete Management
-  Cost Control Management
-  Shortage Management
-  Alternative Solution
-  Excess Inventory Management