



MachXO5-NX Family

Data Sheet

FPGA-DS-02102-1.0

October 2022

Disclaimers

Lattice makes no warranty, representation, or guarantee regarding the accuracy of information contained in this document or the suitability of its products for any particular purpose. All information herein is provided AS IS, with all faults and associated risk the responsibility entirely of the Buyer. Buyer shall not rely on any data and performance specifications or parameters provided herein. Products sold by Lattice have been subject to limited testing and it is the Buyer's responsibility to independently determine the suitability of any products and to test and verify the same. No Lattice products should be used in conjunction with mission- or safety-critical or any other application in which the failure of Lattice's product could create a situation where personal injury, death, severe property or environmental damage may occur. The information provided in this document is proprietary to Lattice Semiconductor, and Lattice reserves the right to make any changes to the information in this document or to any products at any time without notice.

Contents

Acronyms in This Document	8
1. General Description	10
1.1. Features	11
2. Architecture	13
2.1. Overview	13
2.2. PFU Blocks	15
2.3. Routing	19
2.4. SGMII TX/RX	25
2.5. sysMEM Memory	26
2.6. Large RAM	28
2.7. sysDSP	28
2.8. Programmable I/O (PIO).....	31
2.9. Programmable I/O Cell (PIC)	31
2.10. DDR Memory Support	36
2.11. sysI/O Buffer	40
2.12. Analog Interface.....	44
2.13. IEEE 1149.1-Compliant Boundary Scan Testability	44
2.14. Device Configuration.....	44
2.15. Single Event Upset (SEU) Support	46
2.16. On-Chip Oscillator	46
2.17. User I ² C IP.....	46
2.18. User Flash Memory (UFM)	47
2.19. Trace ID	47
2.20. Pin Migration.....	47
2.21. Cryptographic Engine	48
3. DC and Switching Characteristics for Commercial and Industrial.....	49
3.1. Absolute Maximum Ratings	49
3.2. Recommended Operating Conditions ^{1, 2, 3}	50
3.3. Power Supply Ramp Rates	51
3.4. Power up Sequence	51
3.5. On-Chip Programmable Termination.....	51
3.6. Hot Socketing Specifications	52
3.7. Programming /Erase Specifications	52
3.8. ESD Performance	52
3.9. DC Electrical Characteristics	53
3.10. Supply Currents	54
3.11. sysI/O Recommended Operating Conditions.....	54
3.12. sysI/O Single-Ended DC Electrical Characteristics ³	56
3.13. sysI/O Differential DC Electrical Characteristics.....	59
3.14. Maximum sysI/O Buffer Speed	67
3.15. Typical Building Block Function Performance	69
3.16. LMMI	70
3.17. Derating Timing Tables.....	70
3.18. External Switching Characteristics	70
3.19. sysCLOCK PLL Timing (V _{CC} = 1.0 V).....	80
3.20. Internal Oscillators Characteristics.....	81
3.21. Flash Download Time	81
3.22. Flash Program and Erase Current.....	81
3.23. User I ² C Characteristics	81
3.24. Analog-Digital Converter (ADC) Block Characteristics.....	82
3.25. Comparator Block Characteristics	83
3.26. Digital Temperature Readout Characteristics	83

3.27.	Hardened SGMII Receiver Characteristics	83
3.28.	sysCONFIG Port Timing Specifications	84
3.29.	JTAG Port Timing Specifications	88
3.30.	Switching Test Conditions	89
4.	Pinout Information	90
4.1.	Signal Descriptions	90
4.2.	Pin Information Summary	95
5.	Ordering Information.....	98
5.1.	Part Number Description	98
5.2.	Ordering Part Numbers	99
	Supplemental Information.....	100
	For Further Information.....	100
	Revision History	101

Figures

Figure 2.1. Simplified Block Diagram, MachXO5-25 Device (Top Level)	14
Figure 2.2. PFU Diagram	15
Figure 2.3. Slice Diagram	16
Figure 2.4. Slice Configuration for LUT4 and LUT5	17
Figure 2.5. General Purpose PLL Diagram	20
Figure 2.6. Clocking.....	21
Figure 2.7. Edge Clock Sources per Bank	22
Figure 2.8. DCS_CMUX Diagram	23
Figure 2.9. DCS Waveforms	24
Figure 2.10. DLLDEL Functional Diagram	25
Figure 2.11. DDRDLL Architecture	25
Figure 2.12. SGMII CDR IP	26
Figure 2.13. Memory Core Reset	28
Figure 2.14. Comparison of General DSP and MachXO5-NX Approaches	29
Figure 2.15. DSP Functional Block Diagram	30
Figure 2.16. Group of Two High Performance Programmable I/O Cells.....	32
Figure 2.17. Wide Range Programmable I/O Cells	32
Figure 2.18. Input Register Block for PIO on Top, Left, and Right Sides of the Device	33
Figure 2.19. Input Register Block for PIO on Bottom Side of the Device	34
Figure 2.20. Output Register Block on Top, Left, and Right Sides	34
Figure 2.21. Output Register Block on Bottom Side	35
Figure 2.22. Tri-state Register Block on Top, Left, and Right Sides	35
Figure 2.23. Tri-state Register Block on Bottom Side	36
Figure 2.24. DQS Grouping on the Bottom Edge	37
Figure 2.25. DQS Control and Delay Block (DQSBUF)	38
Figure 2.26. sysI/O Banking	42
Figure 2.27. Cryptographic Engine Block Diagram.....	48
Figure 3.1. On-Chip Termination	51
Figure 3.2. LVDS25E Output Termination Example	60
Figure 3.3. SubLVDS Input Interface	60
Figure 3.4. SubLVDS Output Interface	61
Figure 3.5. SLVS Interface	62
Figure 3.6. MIPI Interface	63
Figure 3.7. Receiver RX.CLK.Centered Waveforms	77
Figure 3.8. Receiver RX.CLK.Aligned and DDR Memory Input Waveforms.....	77
Figure 3.9. Transmit TX.CLK.Centered and DDR Memory Output Waveforms.....	77
Figure 3.10. Transmit TX.CLK.Aligned Waveforms	78
Figure 3.11. DDRX71 Video Timing Waveforms	78
Figure 3.12. Receiver DDRX71_RX Waveforms	79
Figure 3.13. Transmitter DDRX71_TX Waveforms.....	79
Figure 3.14. Slave SPI/I ² C/I3C POR/REFRESH Timing.....	85
Figure 3.15. Slave SPI/I ² C/I3C PROGRAMN Timing	86
Figure 3.16. Slave SPI Configuration Timing	86
Figure 3.17. I ² C /I3C Configuration Timing	87
Figure 3.18. Slave SPI/I ² C/I3C Wake-Up Timing.....	87
Figure 3.19. JTAG Port Timing Waveforms	88
Figure 3.20. Output Test Load, LVTTTL and LVCMOS Standards	89
Figure 5.1. Top Marking Diagram	99

Tables

Table 1.1. MachXO5-NX Commercial/Industrial Family Selection Guide	12
Table 2.1. Resources and Modes Available per Slice	15
Table 2.2. Slice Signal Descriptions	17
Table 2.3. Number of Slices Required to Implement Distributed RAM	18
Table 2.4. sysMEM Block Configurations	27
Table 2.5. Maximum Number of Elements in a sysDSP block	31
Table 2.6. Input Block Port Description	33
Table 2.7. Output Block Port Description	35
Table 2.8. Tri-state Block Port Description	36
Table 2.9. DQSBUF Port List Description	38
Table 2.10. Single-Ended I/O Standards	40
Table 2.11. Differential I/O Standards	41
Table 2.12. Single-Ended I/O Standards Supported on Various Sides	43
Table 2.13. Differential I/O Standards Supported on Various Sides	43
Table 2.14. UFM Size	47
Table 3.1. Absolute Maximum Ratings	49
Table 3.2. Recommended Operating Conditions	50
Table 3.3. Power Supply Ramp Rates	51
Table 3.4. Power-On Reset	51
Table 3.5. On-Chip Termination Options for Input Modes	51
Table 3.6. Hot Socketing Specifications for GPIO	52
Table 3.7. Programming/Erase Specifications	52
Table 3.7. DC Electrical Characteristics – Wide Range (Over Recommended Operating Conditions)	53
Table 3.8. DC Electrical Characteristics – High Speed (Over Recommended Operating Conditions)	53
Table 3.9. Capacitors – Wide Range (Over Recommended Operating Conditions)	53
Table 3.10. Capacitors – High Performance (Over Recommended Operating Conditions)	54
Table 3.11. Single Ended Input Hysteresis – Wide Range (Over Recommended Operating Conditions)	54
Table 3.12. Single Ended Input Hysteresis – High Performance (Over Recommended Operating Conditions)	54
Table 3.13. sysI/O Recommended Operating Conditions	54
Table 3.14. sysI/O DC Electrical Characteristics – Wide Range I/O (Over Recommended Operating Conditions)	56
Table 3.15. sysI/O DC Electrical Characteristics – High Performance I/O (Over Recommended Operating Conditions) ³	57
Table 3.16. I/O Resistance Characteristics (Over Recommended Operating Conditions)	57
Table 3.17. V _{IN} Maximum Overshoot/Undershoot Allowance – Wide Range ^{1,2}	58
Table 3.18. V _{IN} Maximum Overshoot/Undershoot Allowance – High Performance ^{1,2}	58
Table 3.19. LVDS DC Electrical Characteristics (Over Recommended Operating Conditions) ¹	59
Table 3.20. LVDS25E DC Conditions	59
Table 3.21. SubLVDS Input DC Electrical Characteristics (Over Recommended Operating Conditions)	60
Table 3.22. SubLVDS Output DC Electrical Characteristics (Over Recommended Operating Conditions)	61
Table 3.23. SLVS Input DC Characteristics (Over Recommended Operating Conditions)	61
Table 3.24. SLVS Output DC Characteristics (Over Recommended Operating Conditions)	62
Table 3.25. Soft D-PHY Input Timing and Levels	64
Table 3.26. Soft D-PHY Output Timing and Levels	65
Table 3.27. Soft D-PHY Clock Signal Specification	65
Table 3.28. Soft D-PHY Data-Clock Timing Specifications	66
Table 3.29. Maximum I/O Buffer Speed ^{1, 2, 3, 4, 7}	67
Table 3.30. Pin-to-Pin Performance	69
Table 3.31. Register-to-Register Performance ^{1, 3, 4}	69
Table 3.32. LMMI F _{MAX} Summary	70
Table 3.33. External Switching Characteristics (V _{CC} = 1.0 V)	70
Table 3.34. sysCLOCK PLL Timing (V _{CC} = 1.0 V)	80
Table 3.35. Internal Oscillators (V _{CC} = 1.0 V)	81
Table 3.36. Flash Download Time	81

Table 3.37. Program and Erase Supply Current	81
Table 3.38. User I ² C Specifications (V _{CC} = 1.0 V).....	81
Table 3.39. ADC Specifications ¹	82
Table 3.40. Comparator Specifications	83
Table 3.41. DTR Specifications ^{1, 2}	83
Table 3.42. SGMII Rx	83
Table 3.43. sysCONFIG Port Timing Specifications	84
Table 3.44. JTAG Port Timing Specifications	88
Table 3.45. Test Fixture Required Components, Non-Terminated Interfaces.....	89
Table 4.1. Signal Descriptions	90
Table 4.2. Pin Information Summary	95

Acronyms in This Document

A list of acronyms used in this document.

Acronym	Definition
ADC	Analog to Digital Converter
AHB-Lite	Advanced High-performance Bus-Lite
AI	Artificial Intelligence
APB	Advanced Peripheral Bus
BGA	Ball Grid Array
CDR	Clock and Data Recovery
CRC	Cycle Redundancy Code
CRE	Cryptographic Engine
CSI-2	Camera Serial Interface-2
DCC	Dynamic Clock Control
DCS	Dynamic Clock Select
DDR	Double Data Rate
DLL	Delay Locked Loops
D-PHY	Display Serial Interface-Physical Layer
DRAM	Dynamic Random Access Memory
DSI	Digital Serial Interface
DSP	Digital Signal Processing
DTR	Digital Temperature Readout
EBR	Embedded Block RAM
ECC	Error Correction Coding
ECLK	Edge Clock
FD-SOI	Fully Depleted Silicon on Insulator
FFT	Fast Fourier Transforms
FIFO	First In First Out
FIR	Finite Impulse Response
HP	High Performance
HSP	High Speed Port
JTAG	Joint Test Action Group
LC	Logic Cell
LMMI	Lattice Memory Mapped Interface
LOL	Loss of Lock
LRAM	Large RAM
LVC MOS	Low-Voltage Complementary Metal Oxide Semiconductor
LVDS	Low-Voltage Differential Signaling
LVPECL	Low Voltage Positive Emitter Coupled Logic
LVTTTL	Low Voltage Transistor-Transistor Logic
LUT	Look Up Table
MIPI	Mobile Industry Processor Interface
ML	Machine Learning
MLVDS	Multipoint Low-Voltage Differential Signaling
MSPS	Million Samples per Second
PCI	Peripheral Component Interconnect
PCS	Physical Coding Sublayer
PCLK	Primary Clock
PDPR	Pseudo Dual Port RAM

Acronym	Definition
PFU	Programmable Functional Unit
PIC	Programmable I/O Cells
PLL	Phase Locked Loops
POR	Power On Reset
RAM	Random Access Memory
ROM	Read Only Memory
SAR	Successive Approximation Resistor
SEC	Soft Error Correction
SED	Soft Error Detection
SER	Soft Error Rate
SEU	Single Event Upset
SGMII	Serial Gigabit Media Independent Interface
SLVS	Scalable Low-Voltage Signaling
SPI	Serial Peripheral Interface
SPR	Single Port RAM
SRAM	Static Random Access Memory
subLVDS	(Reduced Voltage) Low Voltage Differential Signaling
TAP	Test Access Port
TDM	Time Division Multiplexing
UFM	User Flash Memory

1. General Description

The MachXO5™-NX family of low-power FPGAs can be used in a wide range of applications, and are optimized for bridging, I/O expansion, and board control and management. It is built on Lattice Nexus FPGA platform, using low-power 28 nm FD-SOI technology. It combines the extreme flexibility of an FPGA with the low power and high reliability (due to the extreme low Soft Error Rate) of FD-SOI technology, and offers small footprint package options.

The MachXO5-NX family supports a variety of interfaces including MIPI D-PHY (CSI-2, DSI), LVDS, SLVS, subLVDS, SGMII (Gigabit Ethernet), and more. It includes embedded flash memory for on-chip multi-boot and UFM.

Processing features of the first MachXO5-NX device include 27k logic cells, 20 18 × 18 multipliers, 1.9 Mb of embedded memory (consisting of EBR and LRAM blocks), distributed memory, DRAM interfaces (supporting DDR3, DDR3L, LPDDR2, and LPDDR3 up to 1066 Mbps × 16 data width).

The MachXO5-NX FPGA supports the fast configuration of its reconfigurable SRAM-based logic fabric, and ultra-fast configuration of its programmable sysI/O™ from on-chip Flash. To secure user designs, the MachXO5-NX security features include bitstream encryption, authentication, and password protection. In addition to the high reliability inherent to FD-SOI technology (due to its extreme low SER), active reliability features such as built-in frame-based SED/SEC (for SRAM-based logic fabric), and ECC (for EBR and LRAM) are also supported. Built-in ADC is available in each device for system monitoring functions.

Lattice Radiant™ design software allows large complex user designs to be efficiently implemented on the MachXO5-NX FPGA family. Synthesis library support for MachXO5-NX devices is available for popular logic synthesis tools. Radiant tools use the synthesis tool output along with constraints from its floor planning tools, to place and route the user design in MachXO5-NX device. The tools extract timing from the routing, and back-annotate it into the design for timing verification.

Lattice Semiconductor provides many pre-engineered Intellectual Property (IP) modules for the MachXO5-NX family. By using these configurable soft IP cores as standardized blocks, you are free to concentrate on the unique aspects of your design, increasing your productivity.

1.1. Features

- Programmable Architecture
 - 27k logic cells
 - 20 18 × 18 multipliers (in sysDSP™ blocks)
 - 1.9 Mb of embedded memory blocks (EBR, LRAM)
 - 200 to 300 programmable sysI/O (High Performance and Wide Range I/O)
- Programmable sysI/O supports wide varieties of interfaces
 - High Performance (HP) on bottom I/O dual rank
 - Supports up to 1.8 V V_{CCIO}
 - Mixed voltage support (1.0 V, 1.2 V, 1.5 V, 1.8 V)
 - High-speed differential up to 1.2 Gbps
 - Supports soft D-PHY (Tx/Rx), LVDS 7:1 (Tx/Rx), SLVS (Tx/Rx), subLVDS (Rx)
 - Supports SGMII (Gb Ethernet) – two channels (Tx/Rx) at 1.25 Gbps
 - Dedicated DDR3/DDR3L and LPDDR2/LPDDR3 memory support with DQS logic, up to 1066 Mbps data-rate and ×16 data-width
 - Wide Range (WR) on Left, Right and Top I/O Banks
 - Supports up to 3.3 V V_{CCIO}
 - Mixed voltage support (1.2 V, 1.5 V, 1.8 V, 2.5 V, 3.3 V)
 - Programmable slew rate (slow, medium, fast)
 - Controlled impedance mode
 - Emulated LVDS support
 - Hot socketing support
- Power Modes – Low-Power versus High-Performance modes
 - User selectable
 - Low-Power mode for power and/or thermal challenges
 - High-Performance mode for faster processing
- Small footprint package options
 - 14 × 14 mm to 17 × 17 mm package options
- Two channels of Clock Data Recovery (CDR) up to 1.25 Gbps to support SGMII using HP I/O
 - CDR for RX
 - 8b/10b decoding
 - Independent Loss of Lock (LOL) detector for each CDR block
- sysCLOCK™ analog PLLs
 - Two for 27k LC device
 - Six outputs per PLL
 - Fractional N
 - Programmable and dynamic phase control
- sysDSP enhanced DSP blocks
 - Hardened pre-adder
 - Dynamic Shift for AI/ML support
 - Four 18 × 18, eight 9 × 9, two 18 × 36, or 36 × 36 multipliers
 - Advanced 18 × 36, two 18 × 18, or four 8 × 8 MAC
- Flexible memory resources
 - 1.4 Mb sysMEM™ Embedded Block RAM (EBR)
 - Programmable width
 - Error Correction Coding (ECC)*
 - First Input First Output (FIFO)
 - 80 kbit distributed RAM
 - Large RAM Blocks
 - 0.5 Mb per block
- Internal bus interface support
 - APB control bus
 - AHB-Lite for data bus
 - AXI4-streaming
- Non-Volatile Configuration – Fast, Secure, On-chip multi-boot
 - Embedded flash memory
 - Single-chip, secure solution
 - JTAG, SPI, I²C and I3C
 - Ultrafast I/O configuration for instant-on support
 - Multi-sectored UFM for customer data storage
 - Bitstream Security
 - Encryption
 - Authentication
- Cryptographic engine
 - Bitstream encryption – using AES-256
 - Bitstream authentication – using ECDSA
 - Hashing algorithms – SHA, HMAC
 - True Random Number Generator
 - AES 128/256 Encryption
- Single Event Upset (SEU) Mitigation Support
 - Extremely low Soft Error Rate (SER) due to FD-SOI technology
 - Soft Error Detection – Embedded hard macro
 - Soft Error Correction – Continuous user operation mode

- Soft Error Injection – Emulate SEU event to debug system error handling
 - Dual ADC – 1 MSPS, 12-bit SAR with Simultaneous Sampling*
 - Two ADCs per device
 - Three Continuous-time Comparators
 - Simultaneous sampling
 - System Level Support
 - IEEE 1149.1 and IEEE 1532 compliant
 - Reveal Logic Analyzer
 - On-chip oscillator for initialization and general use
 - 1.0 V core power supply
- *Note:** Available in select speed grades. See [Ordering Information](#).

Table 1.1. MachXO5-NX Commercial/Industrial Family Selection Guide

Device	LFMXO5-25
Logic Cells ¹	27k
Embedded Memory (EBR) Blocks (18 kb)	80
Embedded Memory (EBR) Bits (kb)	1,440
Distributed RAM Bits (kb)	184
Large Memory (LRAM) Blocks	1
Large Memory (LRAM) Bits (kb)	512
18 × 18 Multipliers	20
ADC Blocks ²	2
450 MHz High Frequency Oscillator	1
128 kHz Low Power Oscillator	1
GPLL	2
UFM (kb)	15,360
Packages (Size, Ball Pitch)	Wide Range (WR) GPIO (Top/Left/Right Banks) / High Performance (HP) GPIOs (Bottom Banks)
256 BBG (14 × 14 mm, 0.8 mm)	160/40
400 BBG (17 × 17 mm, 0.8 mm)	252/48

Notes:

1. Logic Cells = LUTs × 1.2 effectiveness.
2. In select speed grades. See [Ordering Information](#).

2. Architecture

2.1. Overview

Each MachXO5-NX device contains an array of logic blocks surrounded by Programmable I/O Cells (PIC). Interspersed between the rows of logic blocks are rows of sysMEM Embedded Block RAM (EBR) and rows of sysDSP Digital Signal Processing blocks, as shown in [Figure 2.1](#). The MachXO5-25 device has one row of DSP blocks and contains four rows of sysMEM EBR blocks. In addition, MachXO5-25 device includes one Large SRAM block. The sysMEM EBR blocks are large, dedicated 18 kbit fast memory blocks and have built-in ECC and FIFO support. Each sysMEM block can be configured to a single, pseudo dual or true dual port memory in a variety of depths and widths as RAM or ROM. Each DSP block supports variety of multiplier, adder configurations with one 108-bit or two 54-bit accumulators supported, which are the building blocks for complex signal processing capabilities.

Each PIC block encompasses two PIO (PIO pairs) with their respective sysI/O buffers. The sysI/O buffers of the MachXO5-NX devices are arranged in up to twelve banks allowing the implementation of a wide variety of I/O standards. The Wide Range (WR) I/O banks that are located in the top, left and right sides of the device provide flexible ranges of general purpose I/O configurations up to 3.3 V V_{CCIO5} . The banks located in the bottom side of the device are dedicated to High Performance (HP) interfaces such as LVDS, MIPI, DDR3, LPDDR2, and LPDDR3 support up to 1.8 V V_{CCIO5} .

The Programmable Functional Unit (PFU) contains the building blocks for logic, arithmetic, RAM and ROM functions. The PFU block is optimized for flexibility, allowing complex designs to be implemented quickly and efficiently. Logic Blocks are arranged in a two-dimensional array. The registers in PFU and sysI/O blocks in MachXO5-NX devices can be configured to be SET or RESET. After power up and the device is configured, it enters into user mode with these registers SET/RESET according to the configuration setting, allowing the device to enter to a known state for predictable system function.

In addition, MachXO5-NX devices provide various system level hard IP functional and interface blocks such as I²C, SGMII/CDR, and ADC blocks. MachXO5-NX devices also provide security features to help secure user designs and deliver more robust reliability features to the user designs by using enhanced frame-based SED/SEC functions.

Other blocks provided include PLLs, DLLs, and configuration functions. The PLL and DLL blocks are located at the corners of each device. MachXO5-NX devices also include Lattice Memory Mapped Interface (LMMI) which is a Lattice standardized interface for simple read and write operations to support controlling internal IPs.

MachXO5-NX devices also provide multiple blocks of User Flash Memory (UFM). The UFM interfaces to the core logic and completes the routing through the LMMI interface. The UFM space also provides the User Key storage for customer security functions. The UFM can also be accessed through the SPI, I²C, and JTAG ports.

Every device in the family has a JTAG port. This family also provides an on-chip oscillator and soft error detect (SED) capability. The MachXO5-NX devices use 1.0 V as their core voltage.

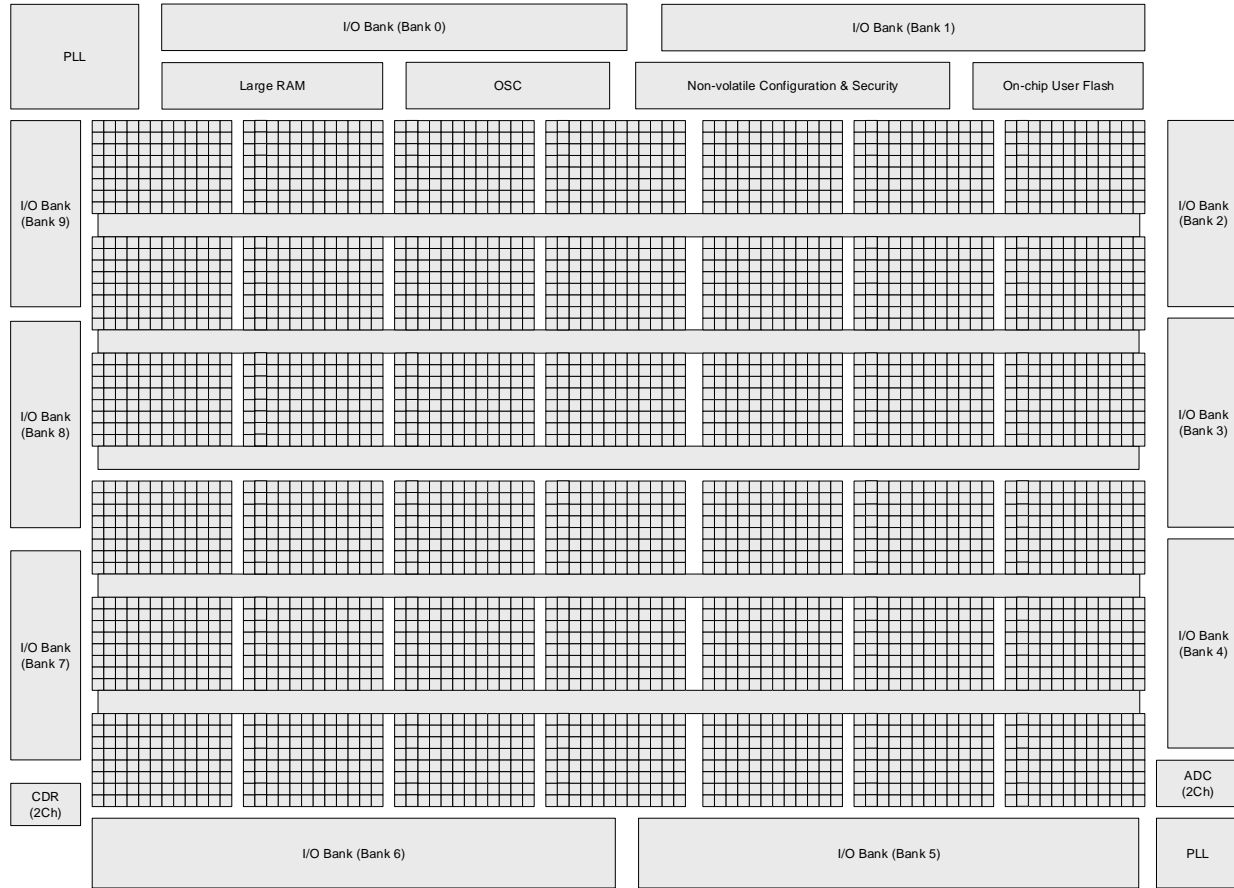

Figure 2.1. Simplified Block Diagram, MachXO5-25 Device (Top Level)

2.2. PFU Blocks

The core of the MachXO5-NX device consists of PFU blocks. Each PFU block consists of four interconnected slices numbered 0-3 as shown in Figure 2.2. Each slice contains two LUTs. All the interconnections to and from PFU blocks are from routing.

The PFU block can be used in Distributed RAM or ROM function, or used to perform Logic, Arithmetic, or ROM functions. Table 2.1 shows the functions each slice can perform in either mode.

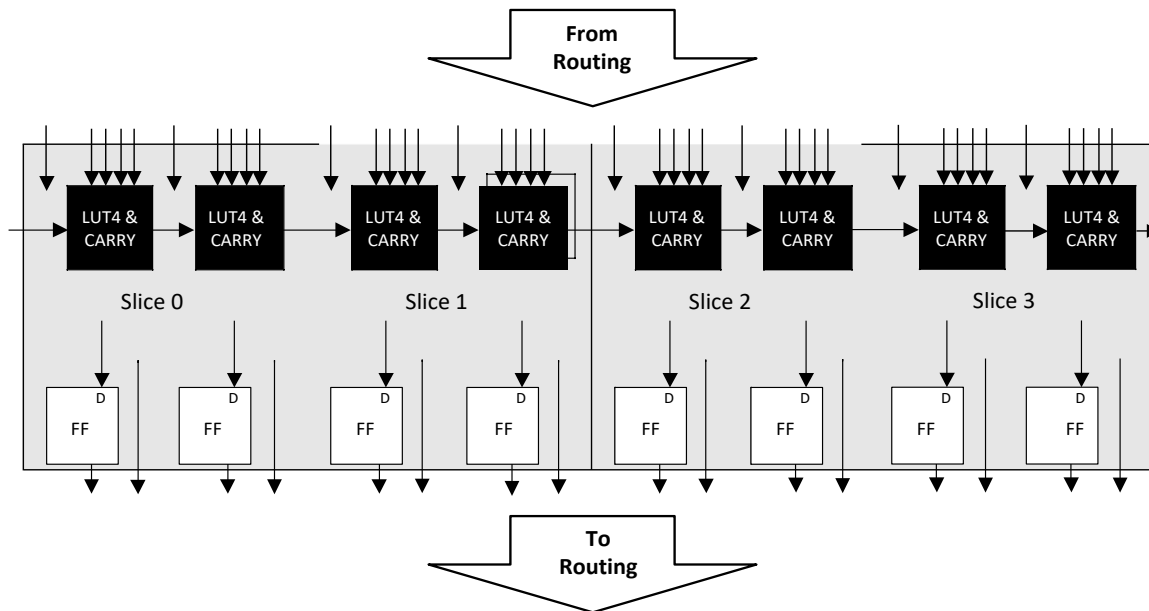

Figure 2.2. PFU Diagram

2.2.1. Slice

Each slice contains two LUT4s feeding two registers. In Distributed SRAM mode, Slice 0 and Slice 1 are configured as distributed memory, Slice 2 is not available as it is used to support Slice 0 and Slice 1, while Slice 3 is available as Logic or ROM. Table 2.1 shows the capability of the slices along with the operation modes they enable. In addition, each Slice contains logic that allows the LUTs to be combined to perform a LUT5 function. There is control logic to perform set/reset functions (programmable as synchronous/ asynchronous), clock select, chip-select, and wider RAM/ROM functions.

Table 2.1. Resources and Modes Available per Slice

Slice	PFU (Used in Distributed SRAM)		PFU (Not used as Distributed SRAM)	
	Resources	Modes	Resources	Modes
Slice 0	2 LUT4s and 2 Registers	RAM	2 LUT4s and 2 Registers	Logic, Ripple, ROM
Slice 1	2 LUT4s and 2 Registers	RAM	2 LUT4s and 2 Registers	Logic, Ripple, ROM
Slice 2	2 LUT4s and 2 Registers	RAM	2 LUT4s and 2 Registers	Logic, Ripple, ROM
Slice 3	2 LUT4s and 2 Registers	Logic, Ripple, ROM	2 LUT4s and 2 Registers	Logic, Ripple, ROM

Figure 2.3 shows an overview of the internal logic of the slice. The registers in the slice can be configured for positive/negative edge trigger.

Each slice has 17 input signals: 16 signals from routing and one from the carry-chain (from the adjacent slice or PFU). Three of them are used for FF control and shared between two slices (0/1 or 2/3). There are five outputs: four to routing and one to carry-chain (to the adjacent PFU). Table 2.2 and Figure 2.3 list the signals associated with all the slices. Figure 2.4 shows the slice signals that support one LUT5 or two LUT5 functions. F0 can be configured to have one LUT4 or LUT5 output while F1 is for a LUT4 output.

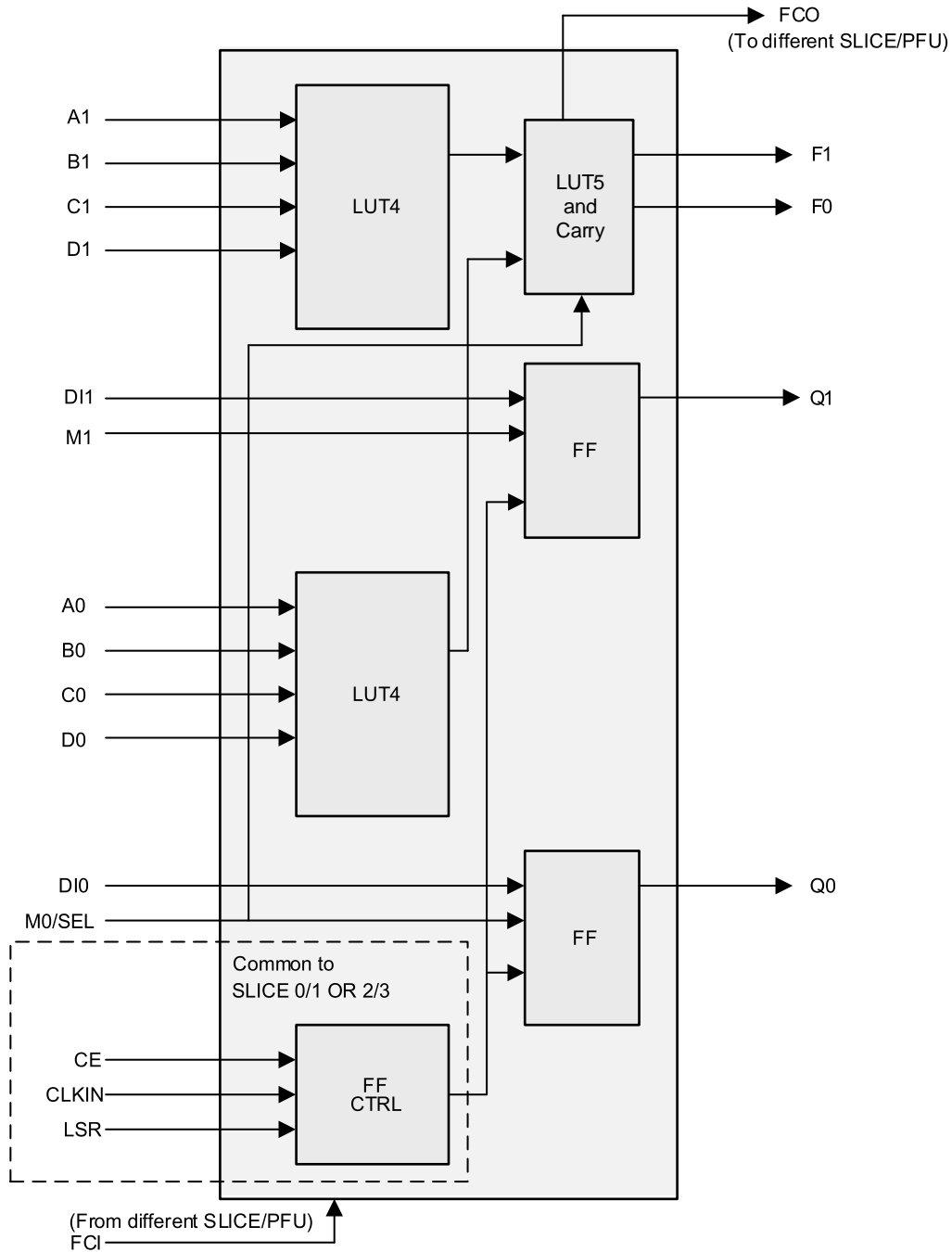

Note: In RAM mode, LUT4s use the following signals:
 QWD0/1
 QWDN0/1
 QWAS00~03, QWAS10~13

Figure 2.3. Slice Diagram

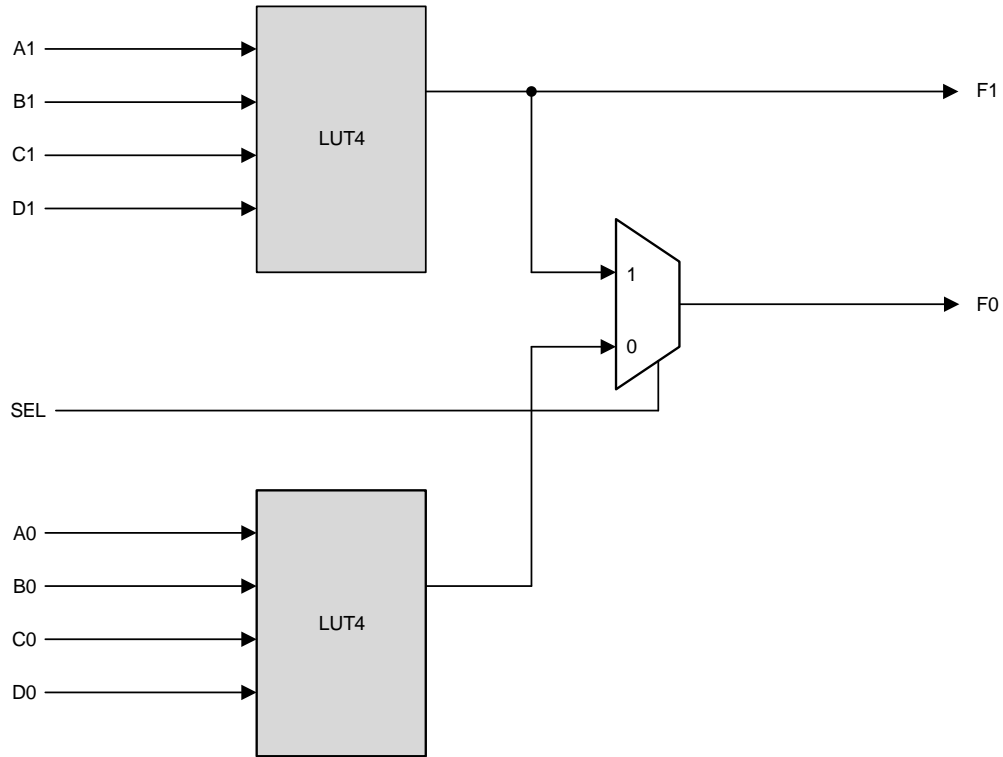

Note: In RAM mode, LUT4s use the following signals:
 QWD0/1
 QWDN0/1
 QWAS00-03, QWAS10-13

Figure 2.4. Slice Configuration for LUT4 and LUT5

Table 2.2. Slice Signal Descriptions

Function	Type	Signal Names	Description
Input	Data signal	A0, B0, C0, D0	Inputs to LUT4
Input	Data signal	A1, B1, C1, D1	Inputs to LUT4
Input	Data signal	M0, M1	Direct input to FF from fabric
Input	Control signal	SEL	LUT5 mux control input
Input	Data signal	DI0, DI1	Inputs to FF from LUT4 F0/F1 outputs
Input	Control signal	CE	Clock Enable
Input	Control signal	LSR	Local Set/Reset
Input	Control signal	CLKIN	System Clock
Input	Inter-PFU signal	FCI	Fast Carry-in ¹
Output	Data signals	F0	LUT4/LUT5 output signal
Output	Data signals	F1	LUT4 output signal
Output	Data signals	Q0, Q1	Register outputs
Output	Inter-PFU signal	FCO	Fast carry chain output ¹

Note:

1. See [Figure 2.3](#) for connection details.

2.2.2. Modes of Operation

Slices 0-2 have up to four potential modes of operation: Logic, Ripple, RAM and ROM. Slice 3 can be used in Logic, Ripple, or ROM modes, but not needed for RAM mode.

2.2.2.1. Logic Mode

In this mode, the LUTs in each slice are configured as 4-input combinatorial lookup tables. A LUT4 can have 16 possible input combinations. Any four input logic functions can be generated by programming this lookup table. Since there are two LUT4s per slice, a LUT5 can be constructed within one slice.

2.2.2.2. Ripple Mode

Ripple mode supports the efficient implementation of small arithmetic functions. In ripple mode, the following functions can be implemented by each slice:

- Addition 2-bit
- Subtraction 2-bit
- Add/Subtract 2-bit using dynamic control
- Up counter 2-bit
- Down counter 2-bit
- Up/Down counter with asynchronous clear 2-bit using dynamic control
- Up/Down counter with preload (sync) 2-bit using dynamic control
- Comparator functions of A and B inputs 2-bit
 - A greater-than-or-equal-to B
 - A not-equal-to B
 - A less-than-or-equal-to B
- Up/Down counter with A greater-than-or-equal-to B comparator 2-bit using dynamic control
- Up/Down counter with A less-than-or-equal-to B comparator 2-bit using dynamic control
- Multiplier support $A_i * B_{j+1} + A_{i+1} * B_j$ in one logic cell with 2 logic cells per slice
- Serial divider 2-bit mantissa, shift 1bit/cycle
- Serial multiplier 2-bit, shift 1bit/cycle or 2bit/cycle

Ripple Mode includes an optional configuration that performs arithmetic using fast carry chain methods. In this configuration (also referred to as CCU2 mode), two additional signals, Carry Generate and Carry Propagate, are generated on a per slice basis to allow fast arithmetic functions to be constructed by concatenating Slices.

2.2.2.3. RAM Mode

In this mode, a 16×4 -bit distributed single or pseudo dual port RAM can be constructed in one PFU using each LUT block in Slice 0 and Slice 1 as a 16×2 -bit memory in each slice. Slice 2 is used to provide memory address and control signals. MachXO5-NX devices support distributed memory initialization.

The Lattice design tools support the creation of a variety of different size memories. Where appropriate, the software constructs these using distributed memory primitives that represent the capabilities of the PFU. [Table 2.3](#) lists the number of slices required to implement different distributed RAM primitives. For more information about using RAM in MachXO5-NX devices, refer to [Memory User Guide for Nexus Platform \(FPGA-TN-02094\)](#).

Table 2.3. Number of Slices Required to Implement Distributed RAM

	SPR 16×4	PDPR 16×4
Number of slices	3	3

Note: SPR = Single Port RAM, PDPR = Pseudo Dual Port RAM

2.2.2.4. ROM Mode

ROM mode uses the LUT logic; hence, Slice 0 through Slice 3 can be used in ROM mode. Preloading is accomplished through the programming interface during PFU configuration.

For more information, refer to [Memory User Guide for Nexus Platform \(FPGA-TN-02094\)](#).

2.3. Routing

There are many resources provided in the MachXO5-NX devices to route signals individually or as busses with related control signals. The routing resources consist of switching circuitry, buffers and metal interconnect (routing) segments. The MachXO5-NX family has an enhanced routing architecture that produces a compact design. The Lattice Radiant software tool suites take the output of the synthesis tool and places and routes the design.

2.3.1. Clocking Structure

The MachXO5-NX clocking structure consists of:

- clock synthesis blocks, sysCLOCK PLL;
- balanced clock tree networks, PCLK and ECLK; and
- efficient clock logic modules, Clock Dividers (PCLKDIV and ECLKDIV) and Dynamic Clock Select (DCS), Dynamic Clock Control (DCC), and DLL.

Each of these functions is described as follow.

2.3.2. Global PLL

The Global PLLs (GPLL) provide the ability to synthesize clock frequencies. The devices in the MachXO5-NX family support two full-featured General Purpose GPLLs. The Global PLLs provide the ability to synthesize clock frequencies. The architecture of the GPLL is shown in [Figure 2.5](#). A description of the GPLL functionality follows.

REFCLK is the reference frequency input to the PLL and its source can come from external CLK inputs or from internal routing. The CLKI input feeds into the input Clock Divider block.

CLKFB is the feedback signal to the GPLL which can come from internal feedback path or routing. The feedback divider is used to multiply the reference frequency and thus synthesize a higher or lower frequency clock output.

The PLL has six clock outputs CLKOP, CLKOS, CLKOS2, CLKOS3, CLKOS4, and CLKOS5. Each output has its own output divider, thus allowing the GPLL to generate different frequencies for each output. The output dividers can have a value from 1 to 128. Each GPLL output can be used to drive the primary clock or edge clock networks.

The setup and hold times of the device can be improved by programming a phase shift into the output clocks which advances or delays the output clock with reference to the un-shifted output clock. This phase shift can either be programmed during configuration or be adjusted dynamically using the DIRSEL, DIR, DYNROTATE, and LOADREG ports.

The LOCK signal is asserted when the GPLL determines it has achieved lock and deasserted if a loss of lock is detected.

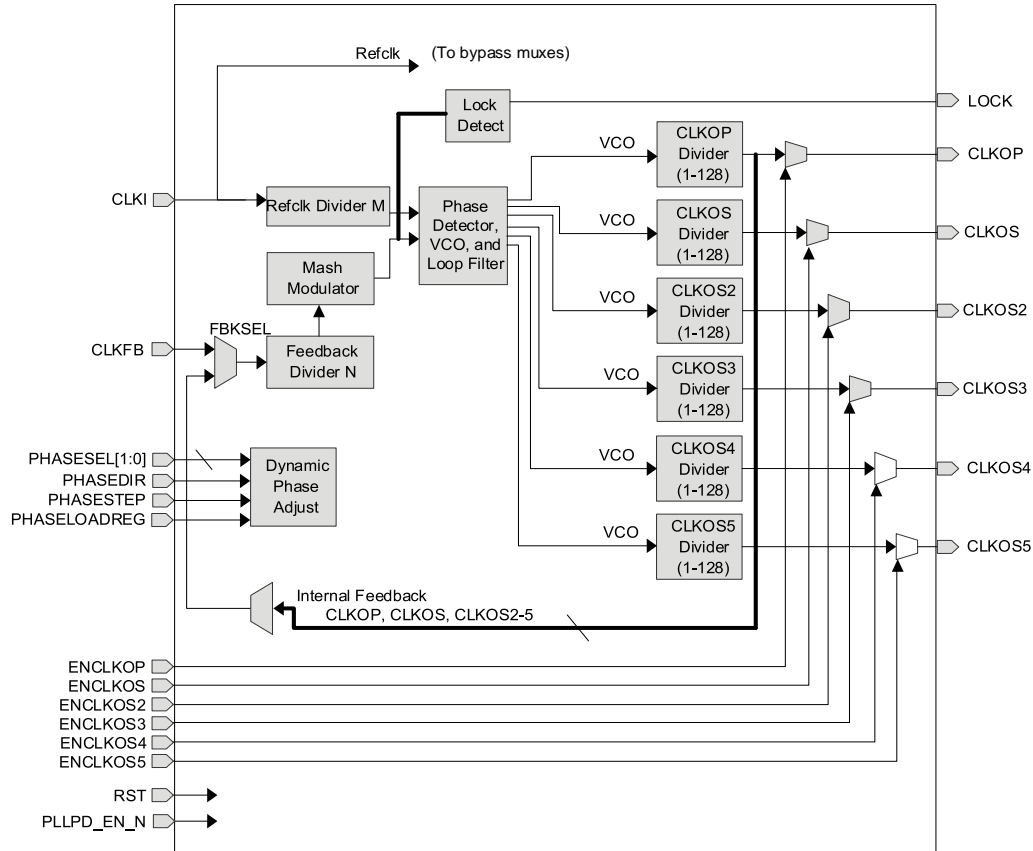

Figure 2.5. General Purpose PLL Diagram

For more details on the PLL, you can refer to the [sysCLOCK PLL Design and User Guide for Nexus Platform \(FPGA-TN-02095\)](#).

2.3.3. Clock Distribution Network

There are two main clock distribution networks for any member of the MachXO5-NX product family, namely Primary Clock (PCLK) and Edge Clock (ECLK). These clock networks can be driven from many different sources, such as Clock Pins, PLL outputs, DLLDEL outputs, Clock divider outputs, and user logic. There are clock divider blocks (ECLKDIV and PCLKDIV) to provide a slower clock from these clock sources.

MachXO5-NX supports glitchless Dynamic Clock Control (DCC) for the PCLK Clock to save dynamic power. There are also Dynamic Clock Selection logic to allow glitchless selection between two clocks for the PCLK network (DCS).

Overview of Clocking Network is shown in [Figure 2.6](#) for MachXO5-NX device.

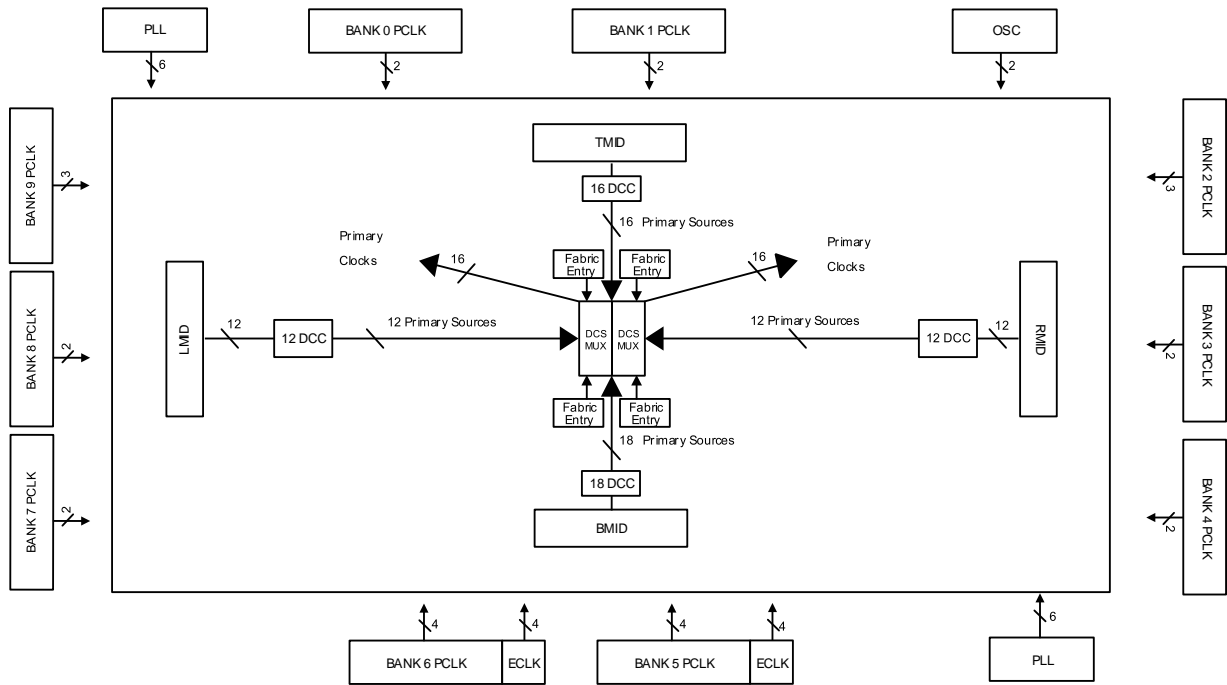

Figure 2.6. Clocking

2.3.4. Primary Clocks

The MachXO5-NX device family provides low-skew, high fan-out clock distribution to all synchronous elements in the FPGA fabric through the Primary Clock Network. The MachXO5-NX PCLK clock network is a balanced clock structure which is designed to minimize the clock skew among all the final destination of the IPs in the FPGA core that needs a clock source.

The primary clock network is divided into two clock domains depending on the device density. Each of these domains has 16 clocks that can be distributed to the fabric in the domain.

The Lattice Radiant software can automatically route each clock to one of the domains up to a maximum of 16 clocks per domain. You can change how the clocks are routed by specifying a preference in the Lattice Radiant software to locate the clock to a specific domain. The MachXO5-NX device provides you with a maximum of 64 unique clock input sources that can be routed to the primary Clock network.

Primary clock sources are:

- Dedicated clock input pins
- PLL outputs
- PCLKDIV, ECLKDIV outputs
- Internal FPGA fabric entries (with minimum general routing)
- SGMII-CDR clocks
- OSC clock

These sources are routed to each of four clock switches called a Mid Mux (LMID, RMID, TMID, BMID). The outputs of the Mid MUX are routed to the center of the FPGA where additional clock switches (DSC_CMUX) are used to route the primary clock sources to primary clock distribution to the MachXO5-NX fabric. These routing muxes are shown in [Figure 2.6](#). There are potentially 64 unique clock domains that can be used in the largest MachXO5-NX device. For more information about the primary clock tree and connections, refer to [sysCLOCK PLL Design and User Guide for Nexus Platform \(FPGA-TN-02095\)](#).

2.3.5. Edge Clock

MachXO5-NX devices have a number of high-speed edge clocks that are intended for use with the PIO in the implementation of high-speed interfaces. There are four (4) ECLK networks per bank I/O on the Bottom side of the devices. For power management, the Edge clock network is powered by a separate power domain (to reduce power noise injection from the core and reduce overall noise induced jitter) while controlled by the same logic that gates the FPGA core and PCLK domains.

Each Edge Clock can be sourced from the following:

- Dedicated PIO Clock input pins (PCLK)
- DLLDEL output (PIO Clock delayed by 90°)
- PLL outputs (CLKOP, CLKOS, CLKOS2, CLKOS3, CLKOS4, and CLKOS5)
- Internal Nodes

Figure 2.7 illustrates the various ECLK sources. Bank 5 is shown in the example. Bank 6 is similar.

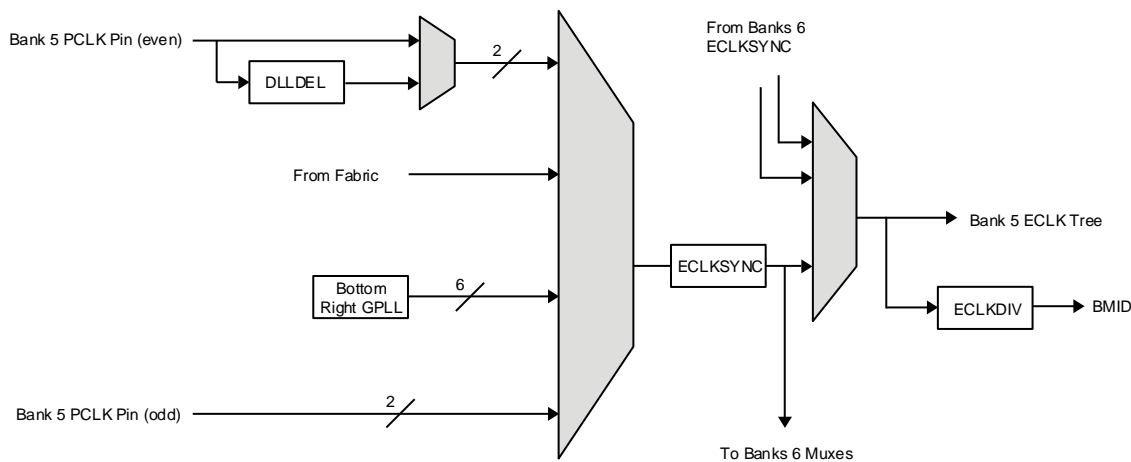

Figure 2.7. Edge Clock Sources per Bank

The edge clocks have low injection delay and low skew. They are typically used for DDR Memory or Generic DDR interfaces. For detailed information on Edge Clock connections, refer to [sysCLOCK PLL Design and User Guide for Nexus Platform \(FPGA-TN-02095\)](#).

2.3.6. Clock Dividers

MachXO5-NX devices have two distinct types of clock divider, Primary and Edge. There are from one (1) to eight (8) Primary Clock Divider (PCLKDIV) and which are located in the DCS_CMUX block(s) at the center of the device. There are eight (8) ECLKDIV dividers per device, locate near the bottom high-speed I/O banks.

The PCLKDIV supports $\div 2$, $\div 4$, $\div 8$, $\div 16$, $\div 32$, $\div 64$, $\div 128$, and $\div 1$ (bypass) operation. The PCLKDIV is fed from a DCSMUX within the DCS_CMUX block. The clock divider output drives one input of the DCS Dynamic Clock Select within the DSC_CMUX block. The Reset (RST) control signal is asynchronously and forces all outputs to low. The divider output starts at next cycle after the reset is synchronously released. The PCLKDIV is shown in [Figure 2.8](#).

The ECLKDIV is intended to generate a slower-speed system clock from a high-speed edge clock. The block operates in a $\div 2$, $\div 3.5$, $\div 4$, or $\div 5$ mode and maintains a known phase relationship between the divided down clock and the high-speed clock based on the release of its reset signal. The ECLKDIV can be fed from selected PLL outputs, external primary clock pins (with or without DLLDEL Delay) or from routing. The clock divider outputs feed into the Bottom Mid-mux (BMID). The Reset (RST) control signal is asynchronous and forces all outputs to low. The divider output starts at next cycle after the reset is synchronously released.

The ECLKDIV block is shown in [Figure 2.7](#). For further information on clock dividers, refer to [sysCLOCK PLL Design and User Guide for Nexus Platform \(FPGA-TN-02095\)](#).

2.3.7. Clock Center Multiplexor Blocks

All clock sources are selected and combined for primary clock routing through the Dynamic Clock Selector Center Multiplexor logic (DCS_CMUX). There are one (1) DCS_CMUX blocks per device. Each DCS_CMUX block contains two (2) DCSCMUX blocks, one (1) PCLKDIV, one (1) DCS block, and two (2) CMUX blocks. See [Figure 2.8](#) for a representative DCS_CMUX block diagram.

The heart of the DCS_CMUX is the Center Multiplexor (CMUX) block, inputs up to 64 feed clock sources [mid-muxes (RMID, LMID, TMIC, BMID) and DCC] and to drive up to 16 primary clock trunk lines.

Up to two (2) clock inputs to the DCS_CMUX can be routed through a Dynamic Clock Select block, and then routed to the CMUX. One (1) input to the DCS can be optionally divided by the Primary Clock Divider (PCLKDIV). For more information about the DCS_CMUX, refer to [sysCLOCK PLL Design and User Guide for Nexus Platform \(FPGA-TN-02095\)](#).

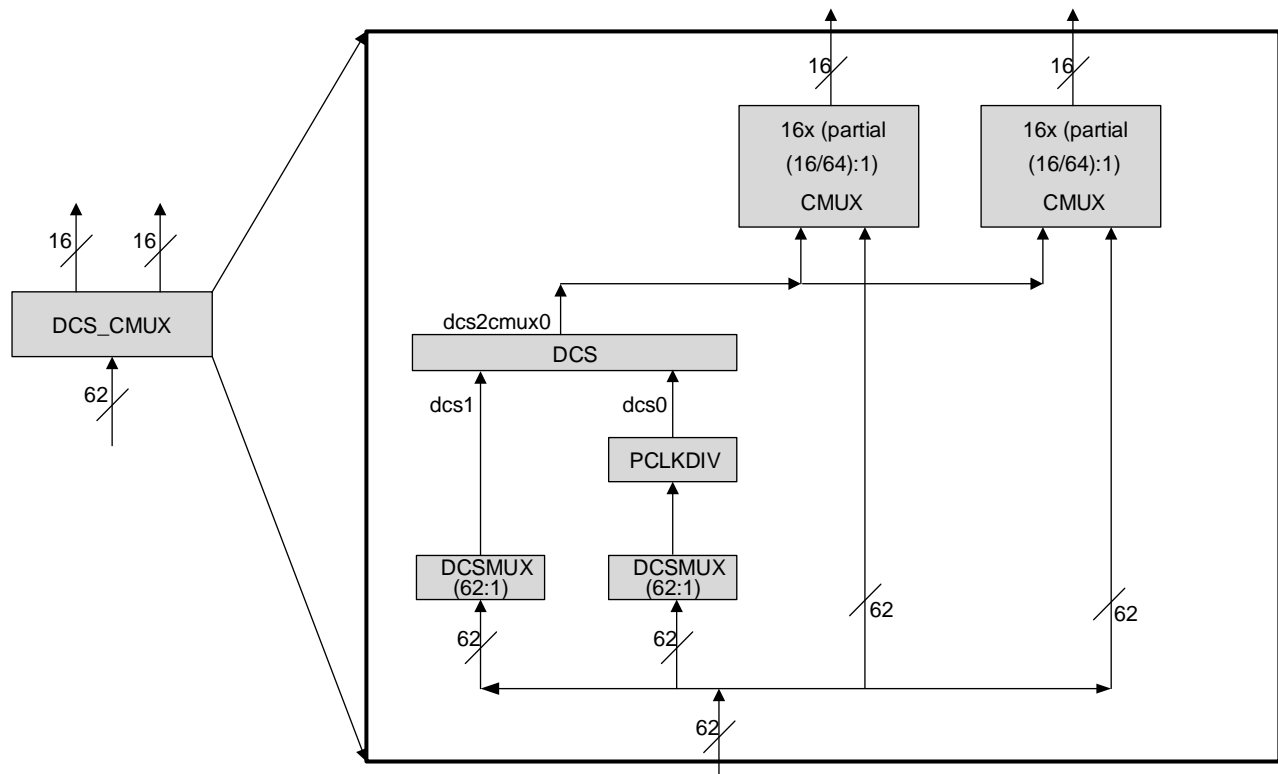

Figure 2.8. DCS_CMUX Diagram

2.3.8. Dynamic Clock Select

The Dynamic Clock Select (DCS) is a smart multiplexer function available in the primary clock routing. It switches between two independent input clock sources. Depending on the operation modes, it switches between two (2) independent input clock sources either with or without any glitches. This is achieved regardless of when the select signal is toggled. Both input clocks must be running to achieve functioning glitchless DCS output clock, but running clocks are not required when used as non-glitchless normal clock multiplexer.

There are one (1) or two (2) DCS blocks per device that feed all clock domains. The DCS blocks are located in the DCS_MUX block. The inputs to the DCS blocks come from MIDMUX outputs and user logic clocks via DCC elements. The DCS elements are located at the center of the PLC array core. The output of the DCS is connected to the inputs of Primary Clock Center MUXs (CMUX).

[Figure 2.9](#) shows the timing waveforms of the default DCS operating mode. The DCS block can be programmed to other modes. For more information about the DCS, refer to [sysCLOCK PLL Design and User Guide for Nexus Platform \(FPGA-TN-02095\)](#).

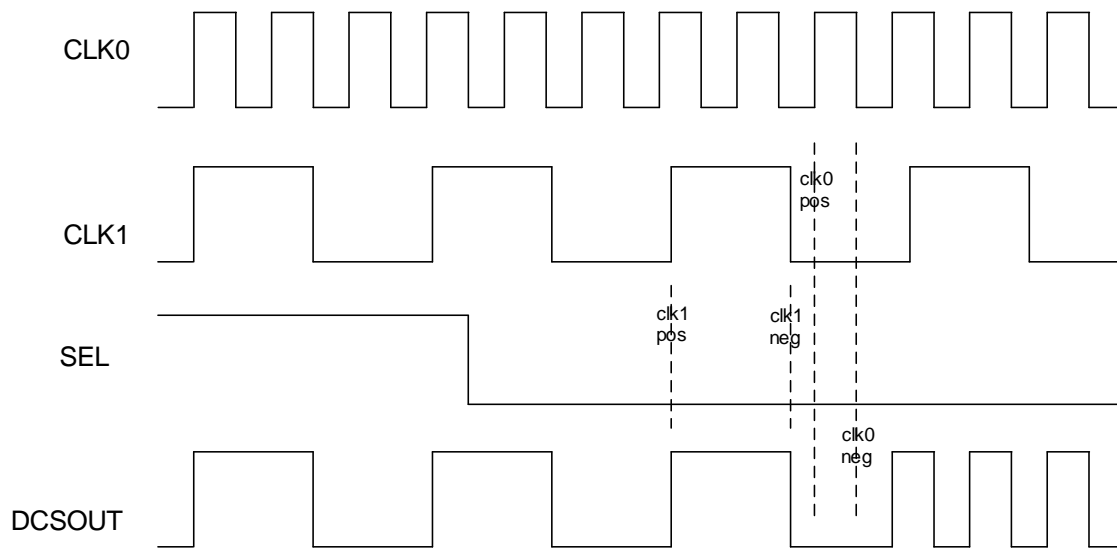

Figure 2.9. DCS Waveforms

2.3.9. Dynamic Clock Control

The Dynamic Clock Control (DCC), Domain Clock enable/disable feature allows internal logic control of the domain primary clock network. When a clock network is disabled, the clock signal is static and not toggle. All the logic fed by that clock does not toggle, reducing the overall power consumption of the device. The disable function is glitchless, and does not increase the clock latency to the primary clock network.

Four additional DCC elements control the clock inputs from the MachXO5-NX domain logic to the Center MUX elements (DSC_CMUX).

This DCC controls the clock sources from the Primary CLOCK MIDMUX before they are fed to the Primary Center MUXs that drive the domain clock network. For more information about the DCC, refer to [sysCLOCK PLL Design and User Guide for Nexus Platform \(FPGA-TN-02095\)](#).

2.3.10. DDRDLL

The MachXO5-NX device has two identical DDRDLL blocks located in the lower left and lower right corners of the device. Each DDRDLL (master DLL block) can generate a phase shift code representing the amount of delay in a delay block that corresponding to 90-degree phase of the reference clock input, and provide this code to every individual DQS block and DLLDEL slave delay element. The reference clock can be either from PLL, or input pin. This code is used in the DQSBUF block that controls a set of DQS pin groups to interface with DDR memory (slave DLL). The DQSBUF uses this code to control the DQS input of the DDR memory to 90-degree shift to clock DQs at the center of the data eye for DDR memory interface.

The code is also sent to another slave DLL, DLLDEL, which takes a primary clock input and generates a 90-degree shift clock output to drive the clocking structure. This is useful to interface edge-aligned Generic DDR, where 90-degree clocking needs to be created. Not all primary clock inputs have associated DLLDEL control. [Figure 2.10](#) shows DDRDLL connectivity to a DLLDEL block (connectivity to DQSBUF blocks is similar).

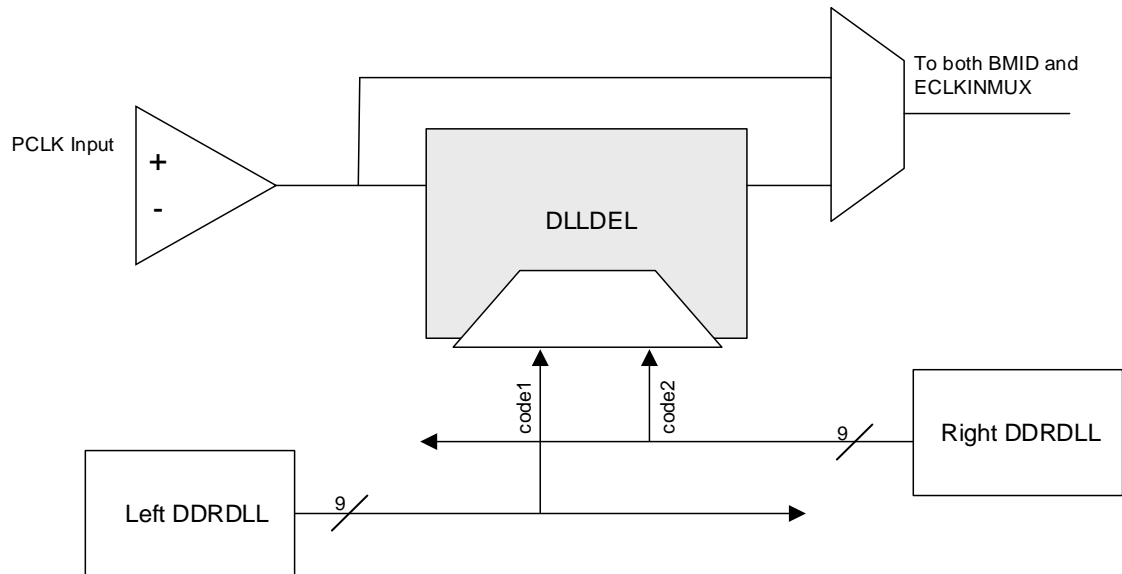

Figure 2.10. DLLDEL Functional Diagram

Each DDRDLL can generate delay code based on the reference clock frequency. The slave DLL (DQSBUF and DLLDEL) uses the code to delay the signal to create the phase shifted signal used either for DDR memory or for creating 90-degree shift clock. [Figure 2.11](#) shows the DDRDLL and the slave DLLs on the top level view.

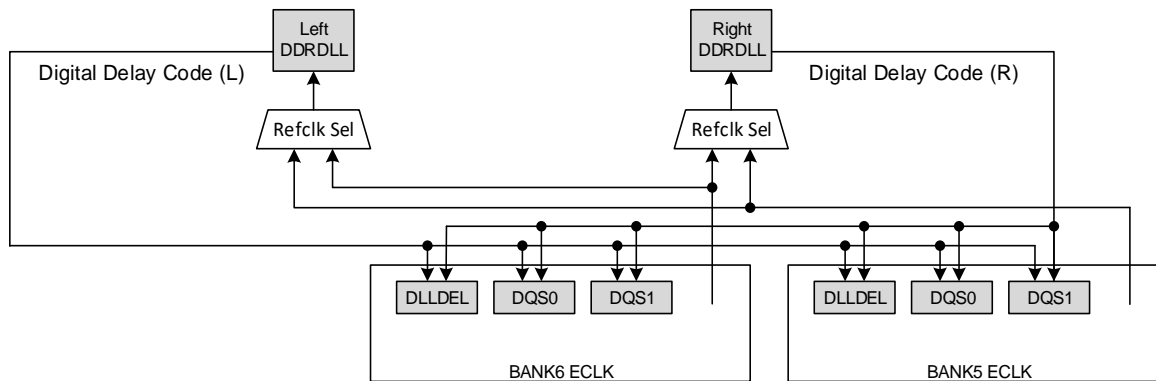

Figure 2.11. DDRDLL Architecture

2.4. SGMII TX/RX

The MachXO5-NX device utilizes different components/resources for the transmit and receive paths of SGMII. For the SGMII transmit path, Generic DDR I/O with X5 gearing are used. For more information, refer to the GDDR5_TX.ECLK.Aligned interface section in the [MachXO5-NX High-Speed I/O Interface \(FPGA-TN-02286\)](#).

For the SGMII receive path, one of the two available hardened CDR (Clock and Data Recovery) Components can be used. There are three main blocks in each CDR: the CDR, deserializer, and FIFO. Each CDR features two loops. The first loop is locked to the reference clock. Once locked, the loop switches to the data path loop where the CDR tracks the data signals to generate the correcting signals that needed to achieve and maintain phase lock with the data. The data is then passed through a deserializer which deserializes the data to 10-bit parallel data. The 10-bit parallel data is then sent to the FIFO bridge, which allows the CDR to interface with the rest of the FPGA.

[Figure 2.12](#) shows a block diagram of the SGMII CDR IP.

The two hardened blocks are located at the bottom left of the chip and uses the high speed I/O Bank 5 for the differential pair input. It is recommended that the reference clock should be entered through a GPIO that has connection to the PLL on the lower left corner as well.

For more information on how to implement the hardened CDR for your SGMII solution, refer to the [SGMII and Gb Ethernet PCS IP Core \(FPGA-IPUG-02077\)](#).

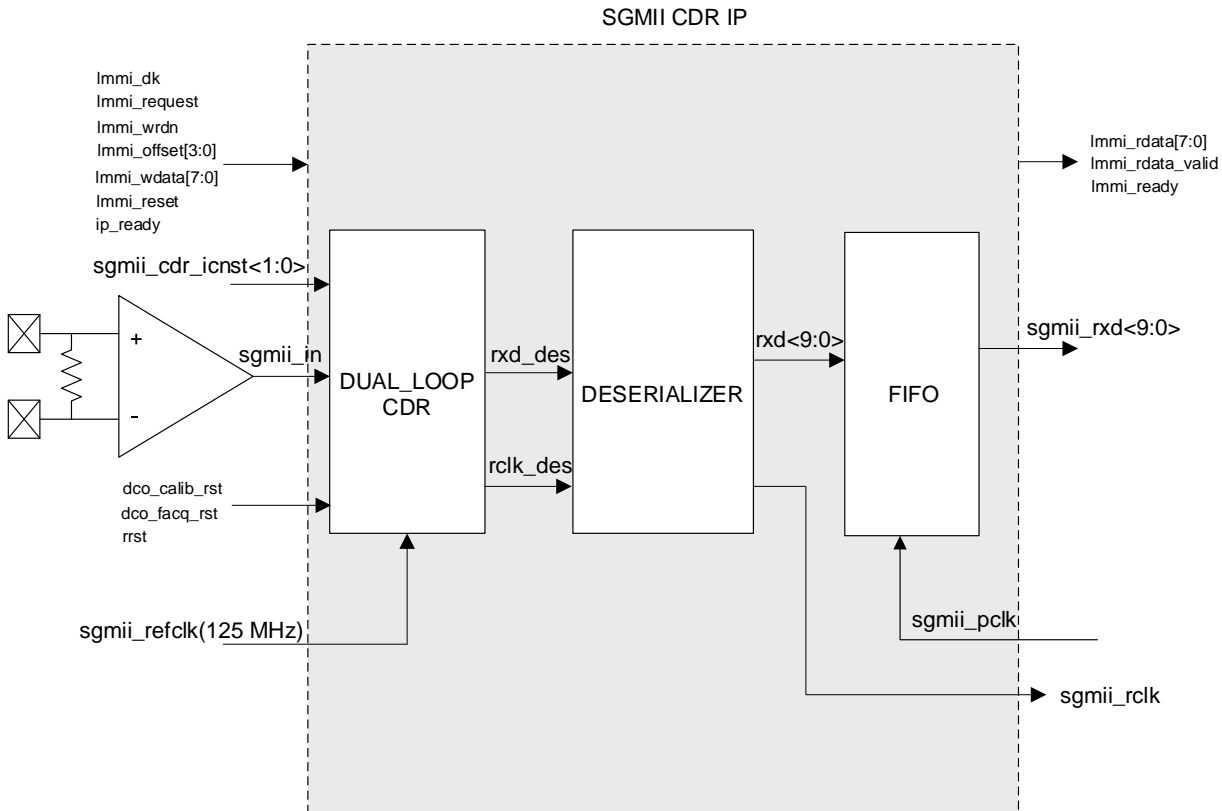

Figure 2.12. SGMII CDR IP

2.5. sysMEM Memory

MachXO5-NX devices contain a number of sysMEM Embedded Block RAM (EBR). The EBR consists of an 18 kb RAM with memory core, dedicated input registers and output registers as well as optional pipeline registers at the outputs. Each EBR includes functionality to support true dual-port, pseudo dual-port, single-port RAM, ROM and built in FIFO. In the MachXO5-NX device, unused EBR blocks is powered down to minimize power consumption.

2.5.1. sysMEM Memory Block

The sysMEM block can implement single port, dual port or pseudo dual port memories. Each block can be used in a variety of depths and widths as listed in [Table 2.4](#). FIFO can be implemented using the built-in read and write address counters and programmable full, almost full, empty and almost empty flags. The EBR block facilitates parity checking by supporting an optional parity bit for each data byte. EBR blocks provide byte-enable support for configurations with 18-bit and 36-bit data widths. For more information, refer to [Memory User Guide for Nexus Platform \(FPGA-TN-02094\)](#).

EBR also provides a built in ECC engine in select speed grades (see Ordering Information). The ECC engine supports a write data width of 32 bits and it can be cascaded for larger data widths such as x64. The ECC parity generator creates and stores parity data for each 32-bit word written. When a read operation is performed, it compares the data with its associated parity data and report back if any Single Event Upset (SEU) event has disturbed the data. Any single bit data disturb is automatically corrected at the data output. In addition, two dedicated error flags indicate if a single-bit or two-bit error has occurred.

Table 2.4. sysMEM Block Configurations

Memory Mode	Configurations
Single Port	16,384 × 1
	8,192 × 2
	4,096 × 4
	2,048 × 9
	1,024 × 18
	512 × 36
True Dual Port	16,384 × 1
	8,192 × 2
	4,096 × 4
	2,048 × 9
	1,024 × 18
	512 × 36
Pseudo Dual Port	16,384 × 1
	8,192 × 2
	4,096 × 4
	2,048 × 9
	1,024 × 18
	512 × 36

2.5.2. Bus Size Matching

All of the multi-port memory modes support different widths on each of the ports (except ECC mode, which only supports a write data width of 32 bits). The RAM bits are mapped LSB word 0 to MSB word 0, LSB word 1 to MSB word 1, and so on. Although the word size and number of words for each port varies, this mapping scheme applies to each port.

2.5.3. RAM Initialization and ROM Operation

If desired, the contents of the RAM can be pre-loaded during device configuration. By preloading the RAM block during the chip configuration cycle and disabling the write controls, the sysMEM block can also be utilized as a ROM.

2.5.4. Memory Cascading

Larger and deeper blocks of RAM can be created using EBR sysMEM Blocks. Typically, the Lattice design tools cascade memory transparently, based on specific design inputs.

2.5.5. Single, Dual and Pseudo-Dual Port Modes

In all the sysMEM RAM modes, the input data and address for the ports are registered at the input of the memory array. The output data of the memory is optionally registered at the output.

2.5.6. Memory Output Reset

The EBR utilizes latches at the A and B output ports. These latches can be reset asynchronously or synchronously. RSTA and RSTB are local signals, which reset the output latches associated with Port A and Port B, respectively. The Global Reset (GSRN) signal can reset both ports. The output data latches and associated resets for both ports are as shown in [Figure 2.13](#). The optional Pipeline Registers at the outputs of both ports are also reset in the same way.

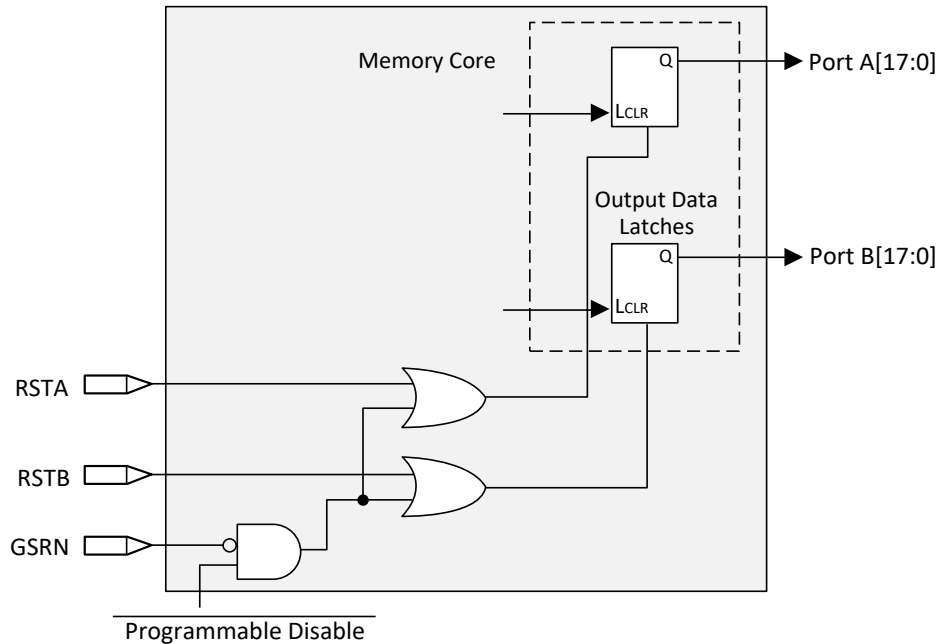

Figure 2.13. Memory Core Reset

For further information on the sysMEM EBR block, see the list of technical documentation in [Supplemental Information](#) section.

2.6. Large RAM

The MachXO5-NX device includes additional memory resources in the form of Large Random-Access Memory (LRAM) blocks.

The LRAM is designed to work as Single-Port RAM, Dual-Port RAM, Pseudo Dual-Port RAM, and ROM memories. It is designed to function as additional memory resources for you beyond what is available in the EBR and PFU.

Each individual Large RAM block contains 0.5 Mb of memory, and has a programmable data width of up to 32 bits. Cascading Large RAM blocks allows data widths up to 64 bits. Additionally, each LRAM can use either Error Correction Coding (ECC) or byte enable.

2.7. sysDSP

The MachXO5-NX family provides an enhanced sysDSP architecture, making it ideally suitable for low-cost, high-performance Digital Signal Processing (DSP) applications. Typical functions used in these applications are Finite Impulse Response (FIR) filters, Fast Fourier Transforms (FFT) functions, Correlators, Reed-Solomon/Turbo/Convolution encoders and decoders. These complex signal processing functions use similar building blocks, such as multiply-adders and multiply-accumulators.

2.7.1. sysDSP Approach Compared to General DSP

Conventional general-purpose DSP chips typically contain one to four (Multiply and Accumulate) MAC units with fixed data-width multipliers; this leads to limited parallelism and limited throughput. Their throughput is increased by higher clock speeds. In the MachXO5-NX device family, there are many DSP blocks that can be used to support different data widths. This allows you to use highly parallel implementations of the DSP functions. You can optimize DSP performance versus area by choosing appropriate levels of parallelism. [Figure 2.14](#) compares the fully serial implementation to the mixed parallel and serial implementation.

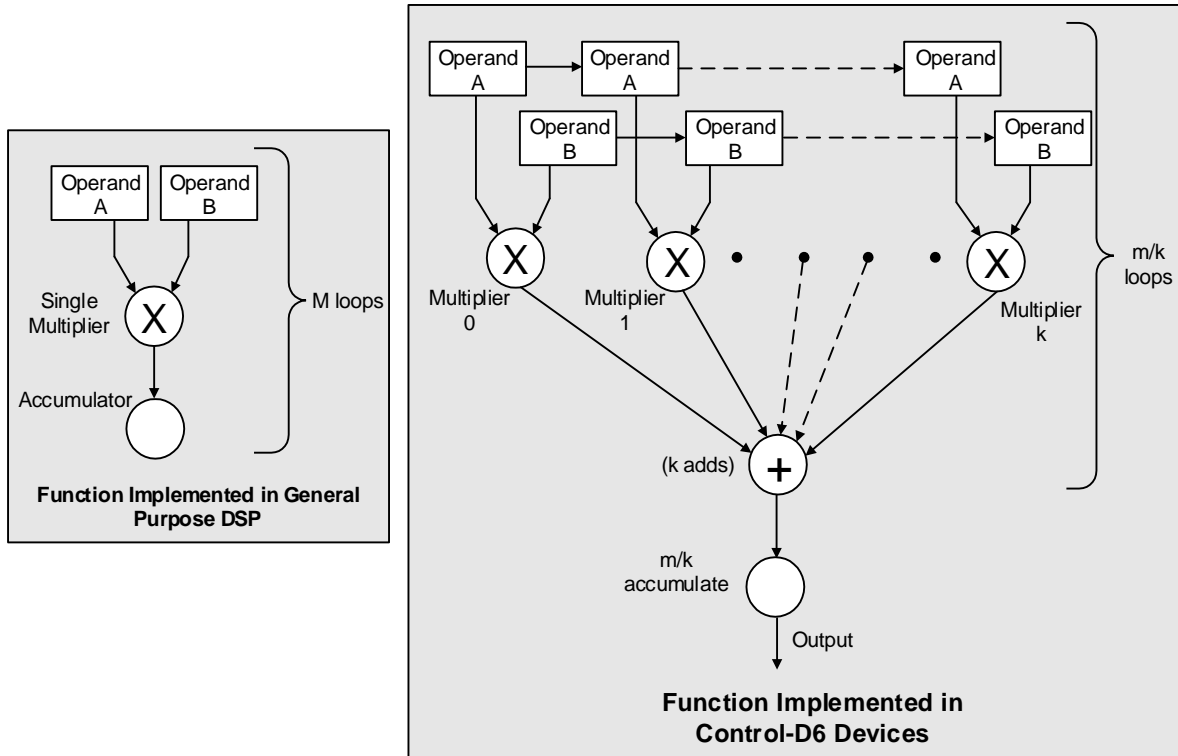

Figure 2.14. Comparison of General DSP and MachXO5-NX Approaches

2.7.2. sysDSP Architecture Features

The MachXO5-NX sysDSP Slice has been significantly enhanced to provide functions needed for advanced processing applications. These enhancements provide improved flexibility and resource utilization.

The MachXO5-NX sysDSP Slice supports many functions that include the following:

- Symmetry support. The primary target application is wireless. 1D Symmetry is useful for many applications that use FIR filters when their coefficients have symmetry or asymmetry characteristics. The main motivation for using 1D symmetry is cost/size optimization. The expected size reduction is up to 2x.
 - Odd Mode – Filter with Odd number of taps
 - Even Mode – Filter with Even number of taps
 - Two dimensional (2D) Symmetry Mode – Supports 2D filters for mainly video applications
- Dual-multiplier architecture. Lower accumulator overhead to half and the latency to half compared to single multiplier architecture.
- Fully cascadable DSP across slices. Support for symmetric, asymmetric and non-symmetric filters.
- Multiply (36 × 36, two 18 × 36, four 18 × 18 or eight 9 × 9)
- Multiply Accumulate (supports one 18 × 36 multiplier result accumulation, two 18 × 18 multiplier result accumulation or four 9 × 9 multiplier result accumulation)
- Two Multiplies feeding one Accumulate per cycle for increased processing with lower latency (two 18 × 18 Multiplies feed into an accumulator that can accumulate up to 54 bits)
- Pipeline registers
- 1D Symmetry support. The coefficients of FIR filters have symmetry or negative symmetry characteristics.
 - Odd Mode – Filter with Odd number of taps
 - Even Mode – Filter with Even number of taps
- 2D Symmetry support. The coefficients of 2D FIR filters have symmetry or negative symmetry characteristics.
 - 3 × 3 and 3 × 5 – Internal DSP Slice support
 - 5 × 5 and larger size 2D blocks – Semi internal DSP Slice support

- Flexible saturation and rounding options to satisfy a diverse set of applications situations
- Flexible cascading DSP blocks
 - Minimizes fabric use for common DSP functions
 - Enables implementation of FIR Filter or similar structures using dedicated sysDSP slice resources only
 - Provides matching pipeline registers
 - Can be configured to continue cascading from one row of sysDSP slices to another for longer cascade chains
- RTL Synthesis friendly synchronous reset on all registers, while still supporting asynchronous reset for legacy users
- Dynamic MUX selection to allow Time Division Multiplexing (TDM) of resources for applications that require processor-like flexibility that enables different functions for each clock cycle

For most cases, as shown in [Figure 2.15](#), the MachXO5-NX sysDSP is backwards-compatible with the LatticeECP3™ sysDSP block, such that, legacy applications can be targeted to MachXO5-NX sysDSP. [Figure 2.15](#) shows the diagram of sysDSP.

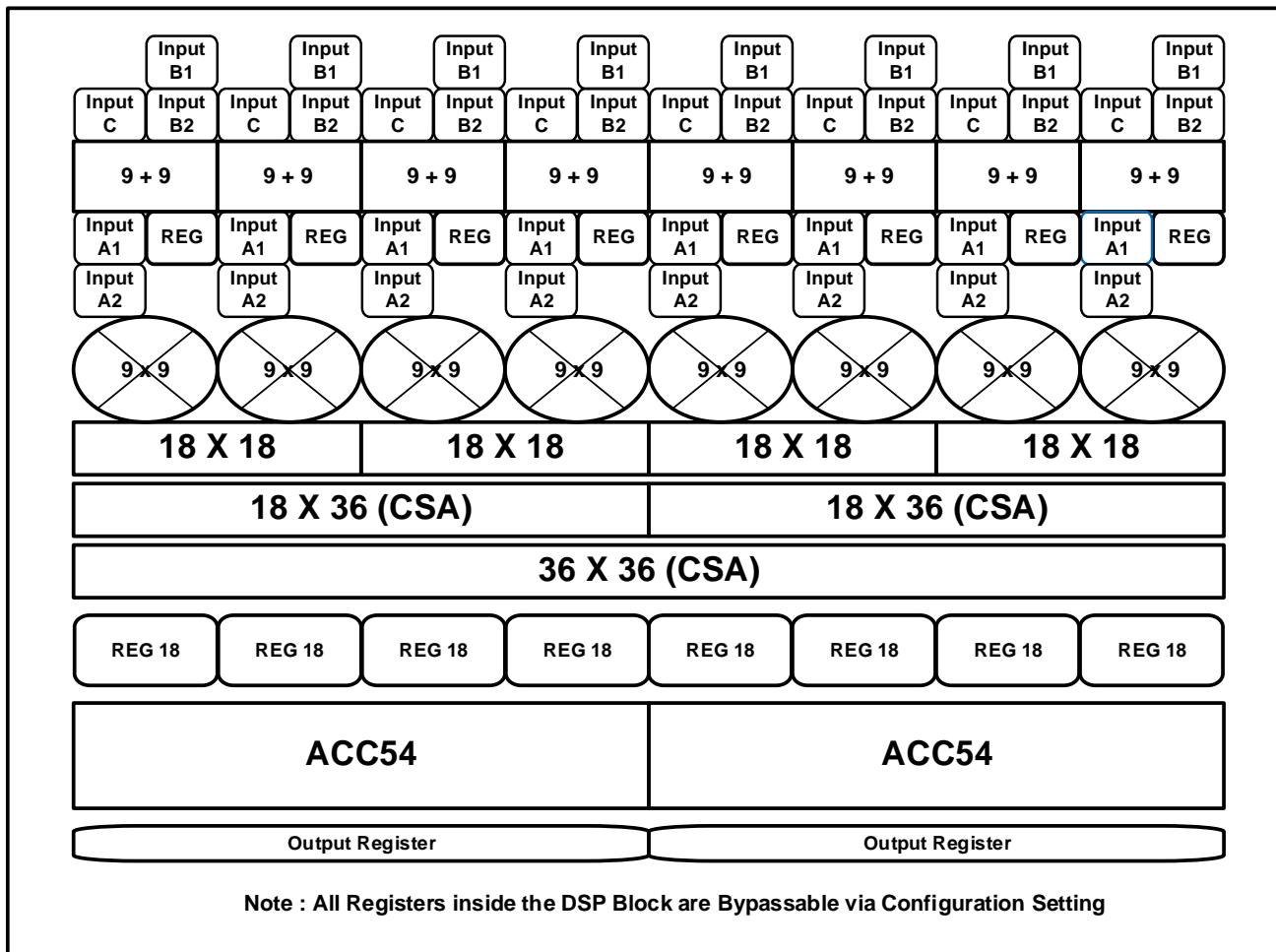

Figure 2.15. DSP Functional Block Diagram

The MachXO5-NX sysDSP block supports the following basic elements.

- MULT (Multiply)
- MAC (Multiply, Accumulate)
- MULTADDSUB (Multiply, Addition/Subtraction)
- MULTADDSUBSUM (Multiply, Addition/Subtraction, Summation)

Table 2.5 shows the capabilities of MachXO5-NX sysDSP block versus the above functions.

Table 2.5. Maximum Number of Elements in a sysDSP block

Width of Multiply	×9	×18	×36
MULT	8	4	1
MAC	2	2	—
MULTADDSUB	2	2	—
MULTADDSUBSUM	2	2	—

Some options are available in the four elements. The input register in all the elements can be directly loaded or can be loaded as a shift register from previous operand registers. By selecting *dynamic operation*, the following operations are possible:

- In the Add/Sub option, the Accumulator can be switched between addition and subtraction on every cycle.
- The loading of operands can switch between parallel and serial operations.

For further information, refer to [sysDSP User Guide for Nexus Platform \(FPGA-TN-02096\)](#).

2.8. Programmable I/O (PIO)

The programmable logic associated with an I/O is called a PIO. The individual PIOs are connected to their respective sysI/O buffers and pads.

On all the MachXO5-NX devices, two adjacent PIO can be combined to provide a complementary output driver pair.

2.9. Programmable I/O Cell (PIC)

The programmable I/O cells (PIC) provide I/O function and necessary gearing logic associated with PIO. MachXO5-NX consists of base PIC and gearing PIC.

Base PICs contain three blocks: an input register block, output register block, and tri-state register block. These blocks contain registers for operating in a variety of modes along with the necessary clock and selection logic. Base PICs cover the top and left/right bank. Gearing PICs contain gearing logic and edge monitor used for locating the center of data window. Gearing PICs cover the bottom banks to support DDR operation.

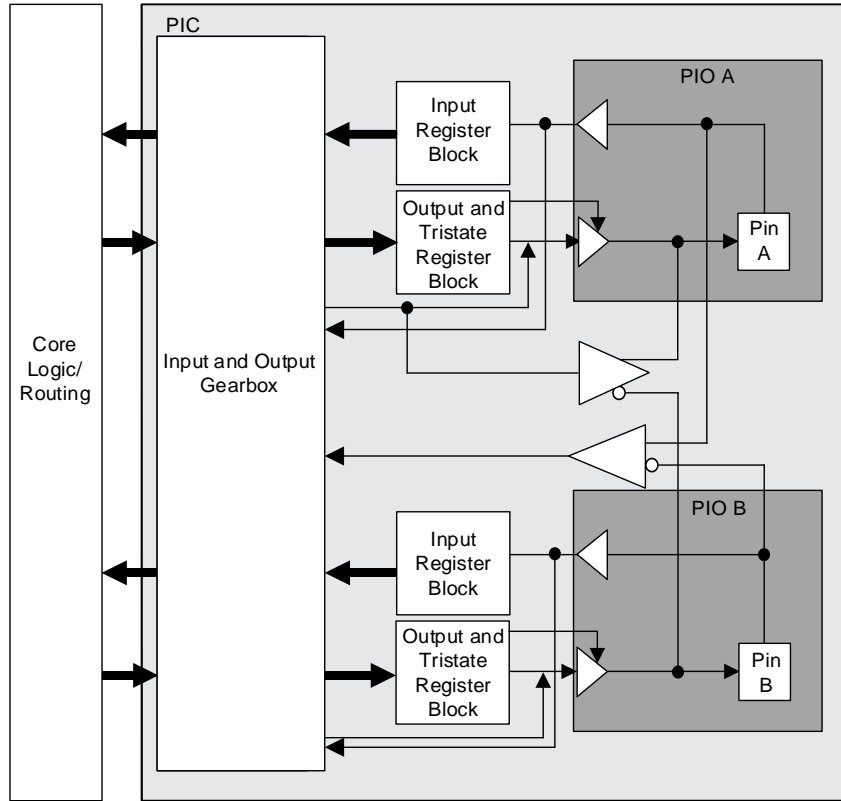

Figure 2.16. Group of Two High Performance Programmable I/O Cells

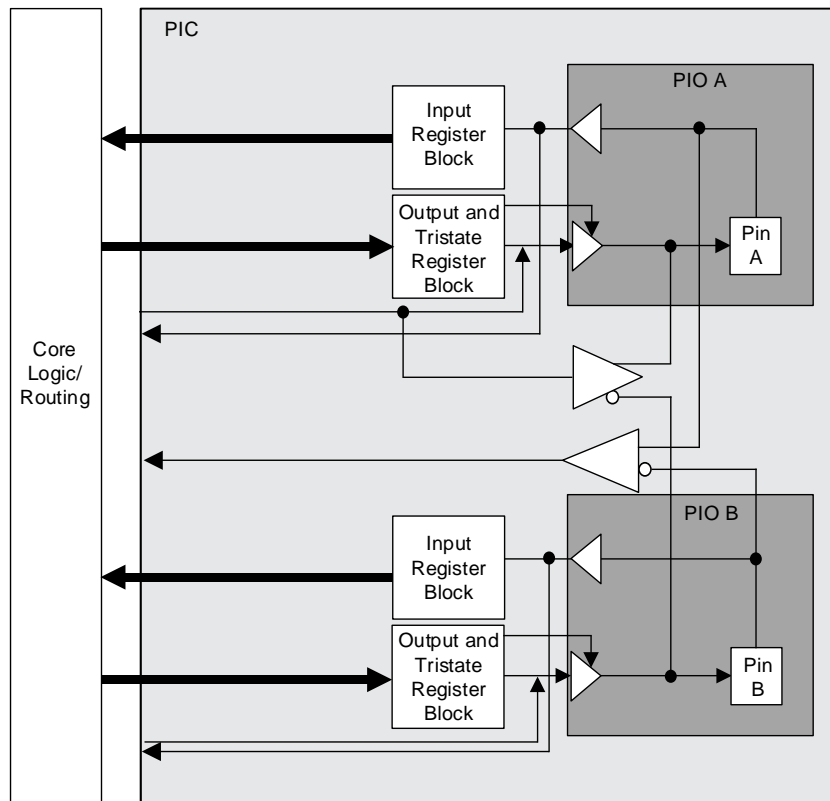

Figure 2.17. Wide Range Programmable I/O Cells

2.9.1. Input Register Block

The input register blocks for the PIO on all edges contain delay elements and registers that can be used to condition high-speed interface signals before they are passed to the device core. In addition, the input register blocks for the PIO on the bottom edges include the built-in FIFO logic to interface to DDR and LPDDR memory.

The Input register block on the bottom side includes gearing logic and registers to implement IDDRX1, IDDRX2, IDDRX4, IDDRX5 gearing functions. With two PICs sharing the DDR register path, it can also implement IDDRX71 function used for 7:1 LVDS interfaces. It uses three sets of registers – shift, update, and transfer to implement gearing and the clock domain transfer. The first stage registers sample the high-speed input data by the high-speed edge clock on its rising and falling edges. The second stage registers perform data alignment based on the control signals. The third stage pipeline registers pass the data to the device core synchronized to the low-speed system clock. For more information on gearing function, refer to [MachXO5-NX High-Speed I/O Interface \(FPGA-TN-02286\)](#).

Input FIFO

The MachXO5-NX PIO has dedicated input FIFO per single-ended pin for input data register for DDR Memory interfaces. The FIFO resides before the gearing logic. It transfers data from DQS domain to continuous ECLK domain. On the Write side of the FIFO, it is clocked by DQS clock, which is the delayed version of the DQS Strobe signal from DDR memory. On the Read side of FIFO, it is clocked by ECLK. ECLK may be any high-speed clock with identical frequency as DQS (the frequency of the memory chip). Each DQS group has one FIFO control block. It distributes FIFO read/write pointer to every PIC in same DQS group. DQS Grouping and DQS Control Block is described in [DDR Memory Support](#) section.

Table 2.6. Input Block Port Description

Name	Type	Description
D	Input	High Speed Data Input
Q[1:0]/Q[3:0]/Q[6:0]/Q[7:0]/Q[9:0]	Output	Low Speed Data to the device core
RST	Input	Reset to the Output Block
SCLK	Input	Slow Speed System Clock
ECLK	Input	High Speed Edge Clock
DQS	Input	Clock from DQS control Block used to clock DDR memory data
ALIGNWD	Input	Data Alignment signal from device core.

Figure 2.18 shows the input register block for the PIO on the top, left, and right edges.

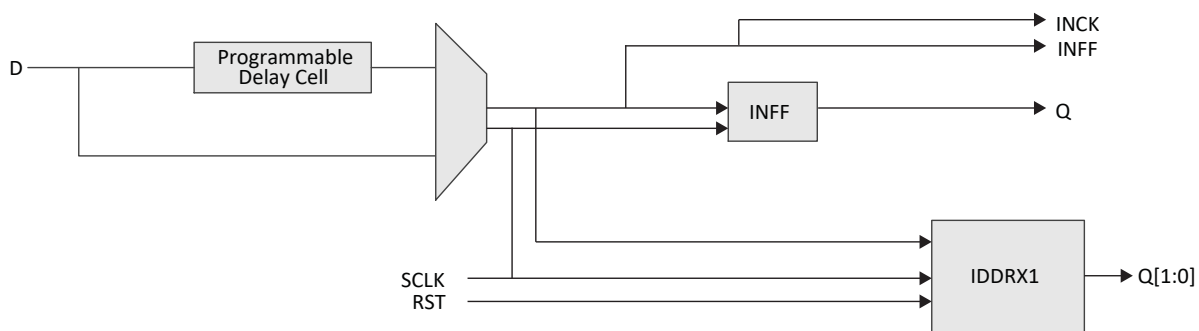
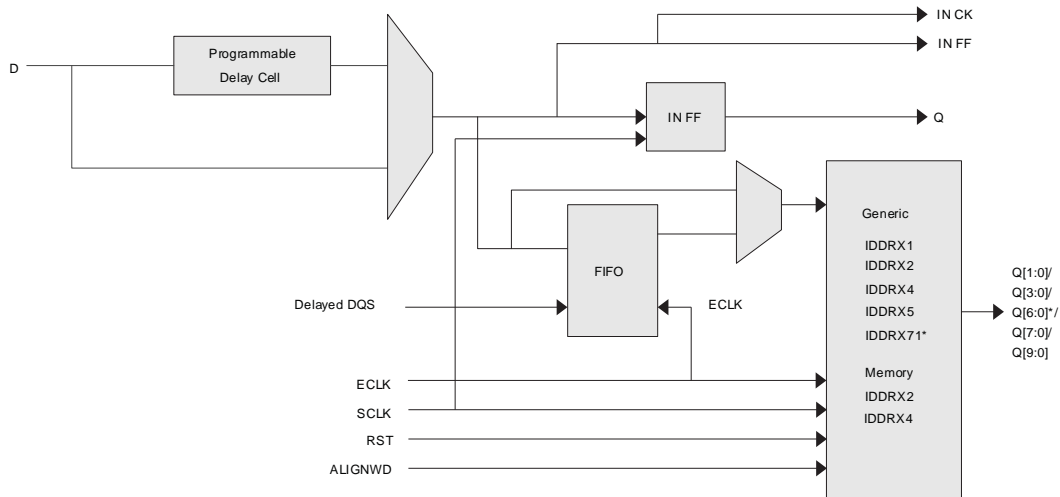

Figure 2.18. Input Register Block for PIO on Top, Left, and Right Sides of the Device

Figure 2.19 shows the input register block for the PIO located on the bottom edge.



*For 7:1 LVDS interface only. It is required to use PIO pair pins (PIOA/B or PIOC/D).

Figure 2.19. Input Register Block for PIO on Bottom Side of the Device

2.9.2. Output Register Block

The output register block registers signal from the core of the device before they are passed to the sysI/O buffers. MachXO5-NX output data path has output programmable flip flops and output gearing logic. On the bottom side, the output register block can support 1x, 2x, x4, x5, and 7:1 gearing enabling high speed DDR interfaces and DDR memory interfaces. On the top, left, and right sides, the banks support 1x gearing. MachXO5-NX output data path diagram is shown in Figure 2.20. The programmable delay cells are also available in the output data path. For detailed description of the output register block modes and usage, you can refer to [MachXO5-NX High-Speed I/O Interface \(FPGA-TN-02286\)](#).

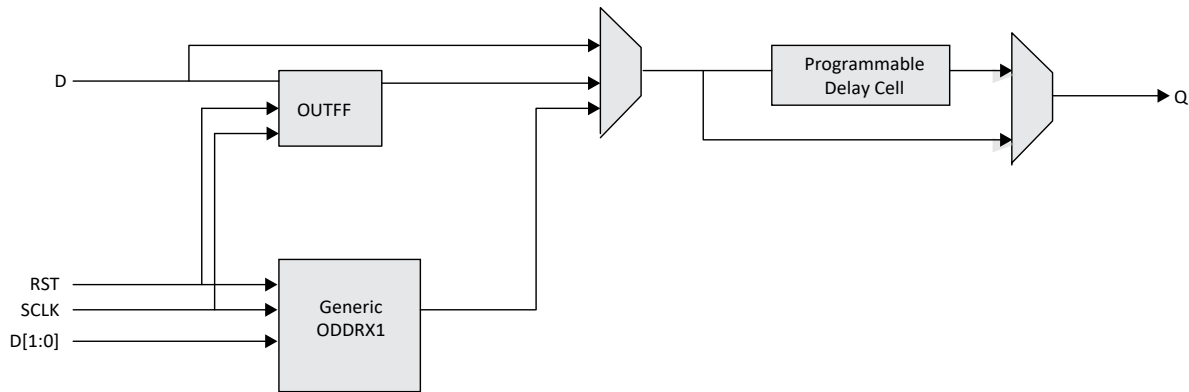
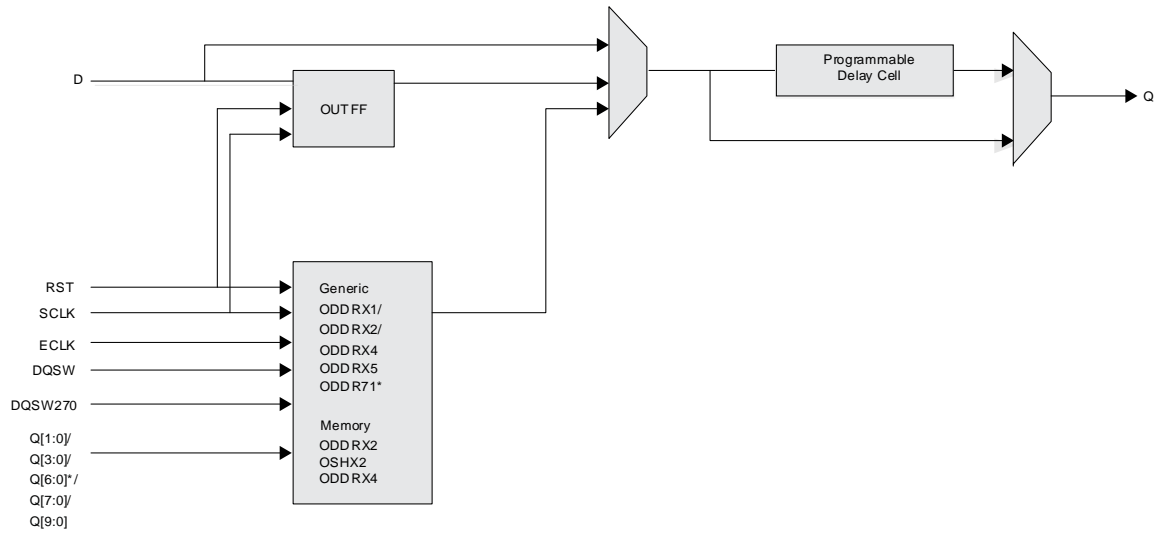

Figure 2.20. Output Register Block on Top, Left, and Right Sides



*For 7:1 LVDS interface only. It is required to use PIO pair pins PIOA/B.

Figure 2.21. Output Register Block on Bottom Side

Table 2.7. Output Block Port Description

Name	Type	Description
Q	Output	High Speed Data Output
D	Input	Data from core to output SDR register
Q[1:0]/Q[3:0]/Q[6:0]/Q[7:0]/Q[9:0]	Input	Low Speed Data from device core to output DDR register
RST	Input	Reset to the Output Block
SCLK	Input	Slow Speed System Clock
ECLK	Input	High Speed Edge Clock
DQSW	Input	Clock from DQS control Block used to generate DDR memory DQS output
DQSW270	Input	Clock from DQS control Block used to generate DDR memory DQ output

2.9.3. Tri-state Register Block

The tri-state register block registers tri-state control signals from the core of the device before they are passed to the sysI/O buffers. The block contains a register for SDR operation. In SDR, TD input feeds one of the flip-flops and then feeds the output. In DDR, operation used mainly for DDR memory interface can be implemented on the bottom side of the device. Here, two inputs feed the tri-state registers clocked by both ECLK and SCLK.

Figure 2.22 and Figure 2.23 show the Tri-state Register Block functions on the device. For detailed description of the tri-state register block modes and usage, refer to [MachXO5-NX High-Speed I/O Interface \(FPGA-TN-02286\)](#).

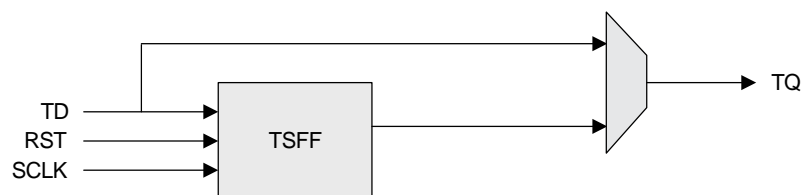

Figure 2.22. Tri-state Register Block on Top, Left, and Right Sides

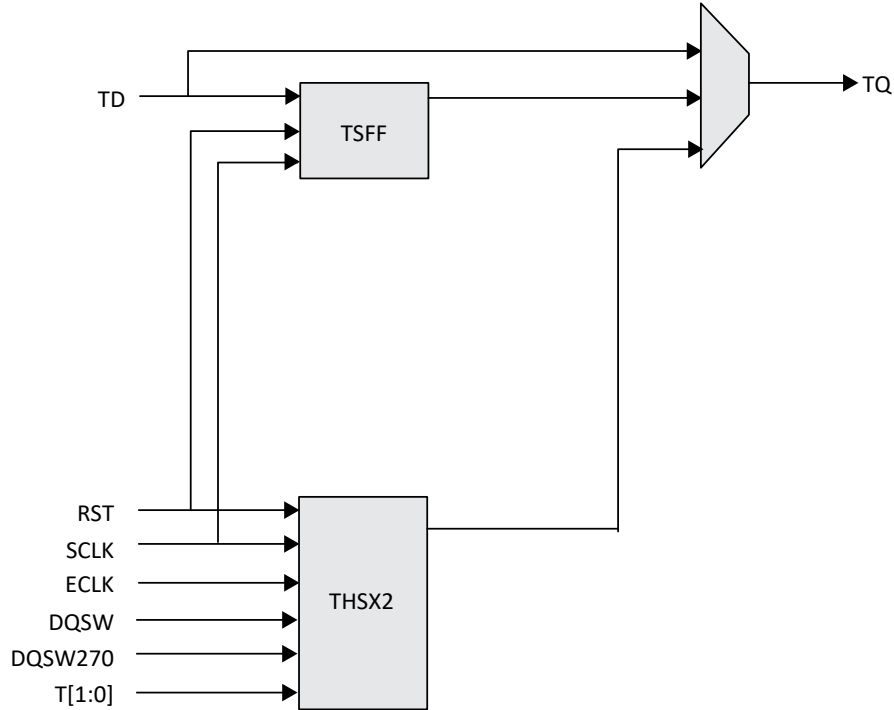

Figure 2.23. Tri-state Register Block on Bottom Side

Table 2.8. Tri-state Block Port Description

Name	Type	Description
TD	Input	Tri-state Input to Tri-state SDR Register
RST	Input	Reset to the Tri-state Block
T[1:0]	Input	Tri-state input to TSHX2 function
SCLK	Input	Slow Speed System Clock
ECLK	Input	High Speed Edge Clock
DQSW	Input	Clock from DQS control Block used to generate DDR memory DQS output
DQSW270	Input	Clock from DQS control Block used to generate DDR memory DQ output
TQ	Output	Output of the Tri-state block

2.10. DDR Memory Support

2.10.1. DQS Grouping for DDR Memory

Some PICs have additional circuitry to allow the implementation of high-speed source synchronous and DDR3/DDR3L, LPDDR2 or LPDDR3 memory interfaces. The support varies by the edge of the device as detailed below.

The Bottom bank PIC has fully functional elements supporting DDR3/DDR3L, LPDDR2, or LPDDR3 memory interfaces. Every 12 PIO on the bottom side are grouped into one DQS group, as shown in Figure 2.24. Within each DQS group, there are two pre-placed pins for DQS and DQS# signals. The rest of the pins in the DQS group can be used as DQ signals and DM signal. The number of the pins in each DQS group bonded out is package dependent. DQS groups with less than 11 pins bonded out can only be used for LPDDR2/3 Command/ Address busses. In DQS groups with more than 11 pins bonded out, up to two pre-defined pins are assigned to be used as virtual V_{CCIO}, by driving these pins to HIGH, and connecting these pins to V_{CCIO} power supply. These connections create soft connections to V_{CCIO} thru these output pins, and make better connections on V_{CCIO} to help to reduce SSO noise. For details, refer to [MachXO5-NX High-Speed I/O Interface \(FPGA-TN-02286\)](#).

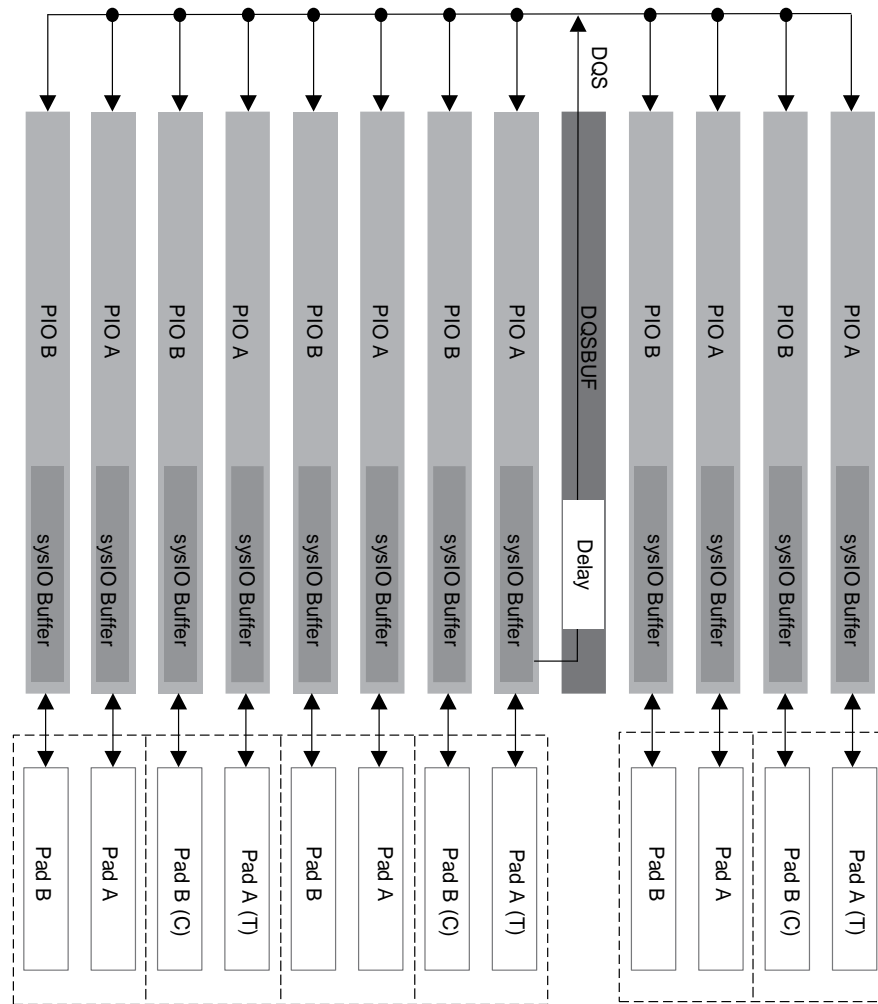

Figure 2.24. DQS Grouping on the Bottom Edge

2.10.2. DLL Calibrated DQS Delay and Control Block (DQSBUF)

To support DDR memory interfaces (DDR3/DDR3L, LPDDR2/3), the DQS strobe signal from the memory must be used to capture the data (DQ) in the PIC registers during memory reads. This signal is output from the DDR memory device aligned to data transitions and must be time shifted before it can be used to capture data in the PIC. This time shift is achieved by using DQSBUF programmable delay line in the DQS Delay Block (DQS read circuit). The DQSBUF is implemented as a slave delay line and works in conjunction with a master DDRDLL.

This block also includes slave delay line to generate delayed clocks used in the write side to generate DQ and DQS with correct phases within one DQS group. There is a third delay line inside this block used to provide the write-leveling feature for DDR write if needed.

Each of the read and write side delays can be dynamically shifted using margin control signals that can be controlled by the core logic.

FIFO Control Block included here generates the Read and Write Pointers for the FIFO block inside the Input Register Block. These pointers are generated to control the DQS to ECLK domain crossing using the FIFO module.

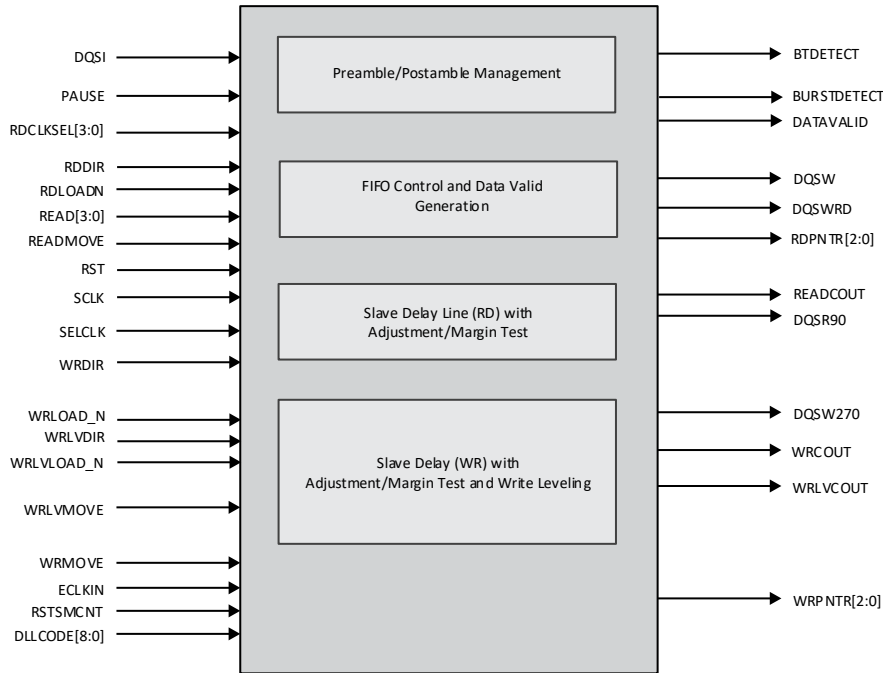

Figure 2.25. DQS Control and Delay Block (DQSBUF)

Table 2.9. DQSBUF Port List Description

Name	Type	Description
DQSI	Input	DQS signal from IO through the PIC.
PAUSE	Input	To stop ECLK for DDR3 Write leveling and DLL code update.
RDCLKSEL[3:0]	Input	Select read clock source and polarity control (from CIB).
RDDIR	Input	0 – to increase the code. 1 – to decrease the code for DDR read.
RDLOADN	Input	1b0 – When mc1_mt_en_read=1b1 and read_load_n=1b0 the read_move pulse needs to be generated to the load the preload value consisting of the {mc1_sign_read, mc1_s_read [8:0]} value. 1b1 – When counter has preload value, read_move pulse can be used to increment and decrement the counter based on the read_direction signal value and mc1_mt_en_write should be set 1b1.
READ[3:0]	Input	Read signal for DDR read mode (from CIB).
READMOVE	Input	Move pulse needs to be at least one (1) sclk cycle and should be greater than 5 ns at TT corner. Pulse is used along with the eclk to generate the internal 'mov' signal to update the counter by one value. The count up or down is determined by the read_direction port.
RST	Input	DQS reset control for both DDR/CDR modes (from CIB).
SCLK	Input	SCLK from SCLK tree (CIB).
SELCLK	Input	Select the clock to be used between the output of the read section's delay cell or sclk.
WRDIR	Input	0 – to increase the code. 1 – to decrease the code for DDR write.

Name	Type	Description
WRLOAD_N	Input	1b0 – When mc1_mt_en_write=1b1 and write_load_n=1b0 the write_move pulse needs to be generated to the load the preload value consisting of the {mc1_sign_write, mc1_s_write [8:0]} value. 1b1 – When counter has preload value, write_move pulse can be used to increment and decrement the counter based on the write_direction signal value and mc1_mt_en_write should be set 1b1.
WRLVDIR	Input	0 – to increase the code. 1 – to decrease the code for DDR write leveling.
WRLVLOAD_N	Input	1b0 – 9-bit counter in reset operation. 1b1 – When mc1_mt_en_write_leveling=1b1 and write_leveling_load_n=1b1 the counter can be incremented/decremented based on the direction signal using the write_leveling_move signal.
WRLVMOVE	Input	Move pulse needs to be at least 1 sclk cycle and should be greater than 5 ns at TT corner. Pulse is used along with the eclk to generate the internal 'mov' signal to update the counter by one value. The count up or down is determined by the write_leveling_direction port.
WRMOVE	Input	Move pulse needs to be at least 1 sclk cycle and should be greater than 5ns at TT corner. Pulse is used along with the eclk to generate the internal 'mov' signal to update the counter by one value. The count up or down is determined by the write_direction port.
ECLKIN	Input	ECLK from four different ECLK tree output.
RSTSMCNT	Input	Signal to reset the smoothing counters used for the Read, Write, and Write leveling delays.
DLLCODE[8:0]	Input	DLL code selected from the DLL code routing mux.
BTDETECT	Output	READ burst detect output (to CIB).
BURSTDTECT	Output	The burst_det_sclk signal is generated using burst_det and is asserted on the rising edge of SCLK.
DATAVALID	Output	Data Valid Flag for READ mode (to CIB).
DQSW	Output	ECLK phase shifted or delayed, goes to the dqsw tree through the PIC.
DQSWRD	Output	The read training clock adjusted in the write section. The read_clk_sel[3:0] determines the selected delay and read enable position.
RDPNTR[2:0]	Output	FIFO control READ pointer (3-bits) to FIFO in PIC (through each tree to IOL).
READCOUT	Output	Margin test output flag for READ to indicate the under-flow or over-flow.
DQSR90	Output	DQSI phase shifted or delayed by 90-degree output (through DQSR tree to IOL).
DQSW270	Output	ECLK phase shifted or delayed by 270-degree output (through DQSW270 tree to IOL).
WRCOUT	Output	Margin test output flag for WRITE to indicate the under-flow or over-flow.
WRLVCOUT	Output	Margin test output flag for WRITE LEVELING to indicate the under-flow or over-flow.
WRPNTR[2:0]	Output	FIFO control WRITE pointer (3-bits) to FIFO in PIC (through each tree to IOL).

2.11. sysI/O Buffer

Each I/O is associated with a flexible buffer referred to as a sysI/O buffer. These buffers are arranged around the periphery of the device in groups referred to as banks. The sysI/O buffers allows you to implement the wide variety of standards that are found in today’s systems including LVDS, HSUL, SSTL Class I and II, LVCMOS, LVTTTL, and MIPI.

The MachXO5-NX family contains multiple Programmable I/O Cell (PIC) blocks. Each PIC contains two Programmable I/O, PIOA and PIOB. Each PIO includes a sysI/O buffer and I/O logic. Two adjacent PIO can be joined to provide a differential I/O pair. These two pairs are referred to as True and Comp, where True Pad is associated with the positive side of the differential I/O, and the complement with the negative.

The top, left and right side banks support I/O standards from 3.3 V to 1.0 V while the bottom supports I/O standards from 1.8 V to 1.0 V. Every pair of I/O on the bottom bank also have a true LVDS and SLVS Tx Driver. In addition, the bottom bank supports single-ended input termination. Both static and dynamic termination are supported. Dynamic termination is used to support the DDR/LPDDR interface standards. For more information about DDR implementation in I/O Logic and DDR memory interface support, refer to [MachXO5-NX High-Speed I/O Interface \(FPGA-TN-02286\)](#).

2.11.1. Supported sysI/O Standards

MachXO5-NX sysI/O buffer supports both single-ended differential and differential standards. Single-ended standards can be further subdivided into internally ratioed standards, such as LVCMOS, LVTTTL, and external referenced standards such as HSUL and SSTL. The buffers support the LVTTTL, LVCMOS 1.0 V, 1.2 V, 1.5 V, 1.8 V, 2.5 V, and 3.3 V standards. Differential standards supported include LVDS, SLVS, differential LVCMOS, differential SSTL, and differential HSUL. For better support of video standards, subLVDS and MIPI_D-PHY are also supported. [Table 2.10](#) and [Table 2.11](#) provide a list of sysI/O standards supported in MachXO5-NX devices.

Table 2.10. Single-Ended I/O Standards

Standard	Input	Output	Bi-directional
LVTTTL33	Yes	Yes	Yes
LVCMOS33	Yes	Yes	Yes
LVCMOS25	Yes	Yes	Yes
LVCMOS18	Yes	Yes	Yes
LVCMOS15	Yes	Yes	Yes
LVCMOS12	Yes	Yes	Yes
LVCMOS10	Yes	No	No
HTSL15 I	Yes	Yes	Yes
SSTL 15 I	Yes	Yes	Yes
SSTL 135 I	Yes	Yes	Yes
HSUL12	Yes	Yes	Yes
LVCMOS18H	Yes	Yes	Yes
LVCMOS15H	Yes	Yes	Yes
LVCMOS12H	Yes	Yes	Yes
LVCMOS10H	Yes	Yes	Yes
LVCMOS10R	Yes	—	Yes ¹

Note:

1. Output supported by LVCMOS10H.

Table 2.11. Differential I/O Standards

Standard	Input	Output	Bi-directional
LVDS	Yes	Yes	Yes
SUBLVDS	Yes	No	—
SLVS	Yes	Yes	—
SUBLVDSE	—	Yes	—
SUBLVDSEH	—	Yes	—
LVDSE	—	Yes	—
MIPI_D-PHY	Yes	Yes	Yes
HSTL15D_I	Yes	Yes	Yes
SSTL15D_I	Yes	Yes	Yes
SSTL15D_II	Yes	Yes	Yes
SSTL135D_I	Yes	Yes	Yes
SSTL135D_II	Yes	Yes	Yes
HSUL12D	Yes	Yes	Yes
LVTTL33D	—	Yes	—
LVC MOS33D	—	Yes	—
LVC MOS25D	—	Yes	—

2.11.2. sysI/O Banking Scheme

MachXO5-NX device has up to ten banks in total. There are two banks on the top, three banks each at the left and right side of the device, and two on the bottom side of the device. Bank 1 can only support V_{CCIO} 3.3 V, Bank 0, Bank 2, Bank 3, Bank 4, Bank 7, Bank 8 and Bank 9 support up to V_{CCIO} 3.3 V, while Bank 5 and Bank 6 can support up to V_{CCIO} 1.8 V. In addition, Bank 5 and Bank 6 support two VREF input for its flexibility to receive two different referenced input levels on the same bank. [Figure 2.26](#) shows the location of each bank.

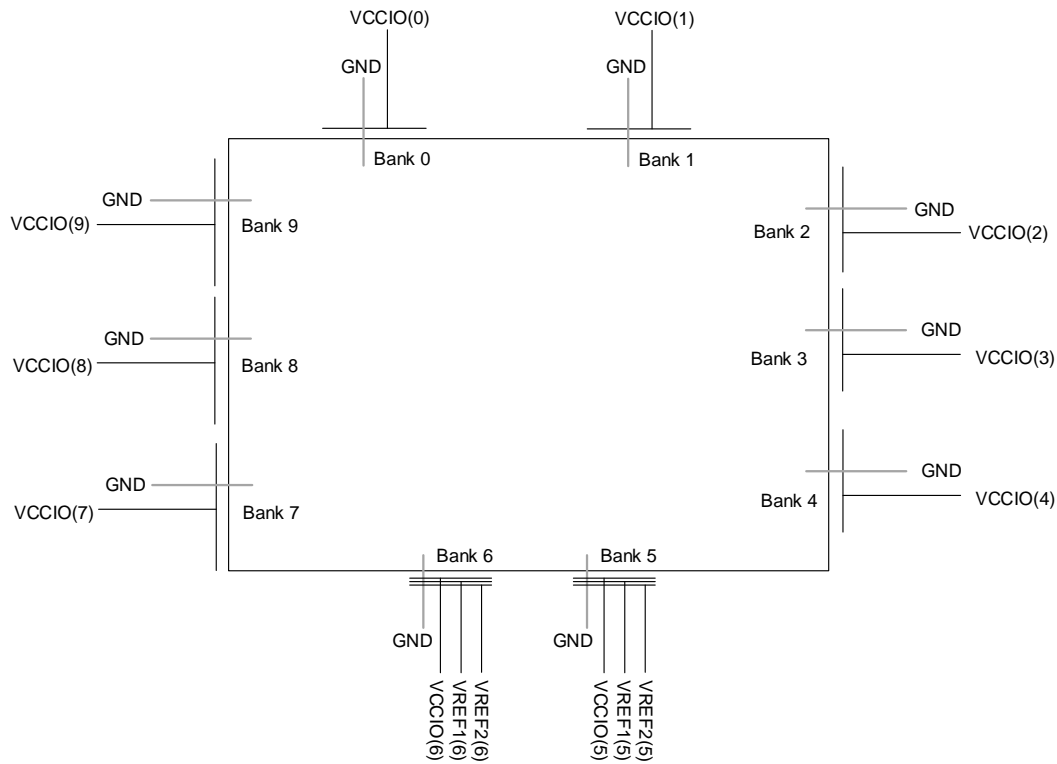

Figure 2.26. sysI/O Banking

2.11.2.1. Typical sysI/O I/O Behavior During Power-up

The internal Power-On-Reset (POR) signal is deactivated when V_{CC} and V_{CCAUX} have reached satisfactory levels. After the POR signal is deactivated, the FPGA core logic becomes active. It is your responsibility to ensure that all other V_{CCIO} banks are active with valid input logic levels to properly control the output logic states of all the I/O banks that are critical to the application. For more information on controlling the output logic state with valid input logic levels during power-up in MachXO5-NX devices, refer to the list of technical documentation in [Supplemental Information](#) section.

The V_{CC} and V_{CCAUX} supply the power to the FPGA core fabric, whereas the V_{CCIO} supplies power to the I/O buffers. In order to simplify the system design while providing consistent and predictable I/O behavior, it is recommended that the I/O buffers be powered-up prior to the FPGA core fabric. For different power supply voltage level by the I/O banks, refer to [sysI/O User Guide for Nexus Platform \(FPGA-TN-02067\)](#) for detailed information.

2.11.2.2. VREF1 and VREF2

Bank 5 and Bank 6 can support two separate VREF input voltage, VREF1, and VREF2. To assign a VREF driver, use `IO_Type = VREF1_DRIVER` or `VREF2_DRIVER`. To assign VREF to a buffer, use `VREF1_LOAD` or `VREF2_LOAD`.

2.11.2.3. sysI/O Standards Supported by I/O Bank

All banks can support multiple I/O standards under the V_{CCIO} rules discussed above. [Table 2.12](#) and [Table 2.13](#) summarize the I/O standards supported on various sides of the MachXO5-NX device.

Table 2.12. Single-Ended I/O Standards Supported on Various Sides

Standard	Top ¹	Left	Right	Bottom
LVTTTL33	Yes	Yes	Yes	—
LVC MOS33	Yes	Yes	Yes	—
LVC MOS25	Yes	Yes	Yes	—
LVC MOS18	Yes	Yes	Yes	—
LVC MOS15	Yes	Yes	Yes	—
LVC MOS12	Yes	Yes	Yes	—
LVC MOS10	Yes	Yes	Yes	—
LVC MOS18H	—	—	—	Yes
LVC MOS15H	—	—	—	Yes
LVC MOS12H	—	—	—	Yes
LVC MOS10H	—	—	—	Yes
LVC MOS10R	—	—	—	Yes
HTSL15 I	—	—	—	Yes
SSTL 15 I, II	—	—	—	Yes
SSTL 135 I, II	—	—	—	Yes
HSUL12	—	—	—	Yes

Note:

- Bank 1 can only support 3.3 V V_{CCIO} .

Table 2.13. Differential I/O Standards Supported on Various Sides

Standard	Top ¹	Left	Right	Bottom
LVDS	—	—	—	Yes
SUBLVDS	—	—	—	Yes
SLVS	—	—	—	Yes
SUBLVDSE	Yes	Yes	Yes	—
SUBLVDSEH	—	—	—	Yes
LVDSE	Yes	Yes	Yes	—
MIPI_D-PHY	—	—	—	Yes
HSTL15D_I	—	—	—	Yes
SSTL15D_I	—	—	—	Yes
SSTL15D_II	—	—	—	Yes
SSTL135D_I	—	—	—	Yes
SSTL135D_II	—	—	—	Yes
HSUL12D	—	—	—	Yes
LVTTTL33D	Yes	Yes	Yes	—
LVC MOS33D	Yes	Yes	Yes	—
LVC MOS25D	Yes	Yes	Yes	—

Note:

- Bank 1 can only support 3.3V V_{CCIO} .

2.11.2.4. Hot Socketing

MachXO5-NX devices have been carefully designed to ensure predictable behavior during power-up and power-down. During power-up and power-down sequences, the I/O remain in tri-state until the power supply voltage is high enough to ensure reliable operation. In addition, leakage into I/O pins is controlled within specified limits. Bank 0, Bank 1, Bank 2, Bank 3, Bank 4, Bank 7, Bank 8, and Bank 9 wide range I/O (excluding INITN/DONE) are fully hot socketable, while Bank 5 and Bank 6 are not supported.

2.11.3. sysI/O Buffer Configurations

This section describes the various sysI/O features available on the MachXO5-NX device. Refer to [sysI/O User Guide for Nexus Platform \(FPGA-TN-02067\)](#) for detailed information.

2.12. Analog Interface

In select speed grades, the MachXO5-NX family provides an analog interface, consisting of two Analog to Digital Converters (ADC), three continuous time comparators and an internal junction temperature monitoring diode. See Ordering Information for more details. The two ADCs can sample the input sequentially or simultaneously.

2.12.1. Analog to Digital Converters

The Analog to Digital Converter is a 12-bit, 1 MSPS SAR (Successive Approximation Resistor/capacitor) architecture converter. The ADC supports both continuous and single shot conversion modes.

The ADC input is selected among pre-selected GPIO input pairs, dedicated analog input pair, the internal junction temperature sensing diode and internal voltage rails. The input signal can be converted in either uni-polar or bi-polar mode.

The reference voltage is selectable between the 1.2 V internal reference generator and an external reference. The ADC can convert up to a 1.8 V input signal with a 1.8 V external reference voltage. The ADC has an auto-calibration function which calibrates the gain and offset.

2.12.2. Continuous Time Comparators

The continuous-time comparator can be used to compare a pre-selected GPIO input pairs or one dedicated comparator input pair. The output of the comparator is provided as continuous and latched data.

2.12.3. Internal Junction Temperature Monitoring Diode

On-die junction temperature can be monitored using the internal junction temperature monitoring diode. The PTAT (proportional to absolute temperature) diode voltage can be monitored by the ADC to provide a digital temperature readout. Refer to [ADC User Guide for Nexus Platform \(FPGA-TN-02129\)](#) for more details.

2.13. IEEE 1149.1-Compliant Boundary Scan Testability

All MachXO5-NX devices have boundary scan cells that are accessed through an IEEE 1149.1 compliant Test Access Port (TAP). This allows functional testing of the circuit board on which the device is mounted through a serial scan path that can access all critical logic nodes. Internal registers are linked internally, allowing test data to be shifted in and loaded directly onto test nodes, or test data to be captured and shifted out for verification. The test access port consists of dedicated I/O: TDI, TDO, TCK, and TMS. The test access port uses V_{CCIO2} for power supply. The test access port is supported for $V_{CCIO2} = 1.8\text{ V} - 3.3\text{ V}$.

For more information, refer to [MachXO5-NX Programming and Configuration User Guide \(FPGA-TN-02271\)](#).

2.14. Device Configuration

All MachXO5-NX devices contain two ports that can be used for device configuration. The Test Access Port (TAP) that supports bit-wide configuration, and the sysCONFIG port that supports serial, quad, and byte configuration. TAP supports both the IEEE Standard 1149.1 Boundary Scan specification and the IEEE Standard 1532 In-System Configuration specification. The JTAG_EN is the only dedicated pin supported by sysCONFIG.

PPROGRAMN/INITN/DONE are enabled by default, but can be turned into GPIO. The remaining sysCONFIG pins are used as dual function pins. Refer to [MachXO5-NX Programming and Configuration User Guide \(FPGA-TN-02271\)](#) for more information about using the dual-use pins as general purpose I/O.

There are various ways to configure a MachXO5-NX device:

- Internal Flash Download
- JTAG

- Inter-Integrated Circuit Bus (I²C)
- Improved Inter-Integrated Circuit Bus (I3C)
- System microprocessor to drive a serial slave SPI port (SSPI mode)
- Lattice Memory Mapped Interface (LMMI), refer to [sysI/O User Guide for Nexus Platform \(FPGA-TN-02067\)](#) for condition.
- JTAG, SSPI, I²C, and I3C are supported for V_{CCIO} = 1.8 V – 3.3 V

On power-up, based on the voltage level (high or low) of the PROGRAMN pin, the FPGA SRAM is configured by the appropriate sysCONFIG port. If PROGRAMN pin is *low*, the FPGA is in the Slave configuration ports (Slave SPI, Slave I²C or Slave I3C) and is waiting for the correct Slave Configuration port activation key. PROGRAMN pin must be driven high within 50 ns of the end of transmission of the Slave Configuration port activation key, that is, the deassertion of SCSN. If no slave port is declared active before the PROGRAMN pin is sensed HIGH, the FPGA is in self-download mode. In self-download mode, the FPGA boots from on-chip flash. Once a configuration port is activated, it remains active throughout that configuration cycle. The IEEE 1149.1 port can be activated any time after power-up by enabling the JTAG_EN pin and sending the appropriate command through the TAP port.

2.14.1. Enhanced Configuration Options

MachXO5-NX devices have enhanced configuration features such as:

- Early I/O release
- Bitstream decryption
- Decompression support
- Watchdog Timer support
- Dual and Multi-boot image support

Early I/O release is a new configuration feature in which certain I/O banks are released earlier so that customer systems have minimal disruption. For more details, refer to [MachXO5-NX Programming and Configuration User Guide \(FPGA-TN-02271\)](#).

Watchdog Timer is a new configuration feature that helps you add a programmable timer option for timeout applications.

2.14.2. Dual-Boot and Multi-Boot Image Support

Dual-boot and multi-boot images are supported for applications requiring reliable remote updates of configuration data for the system FPGA. After the system is running with a basic configuration, a new boot image can be downloaded remotely and stored in a separate location in the configuration storage device. Any time after the update, the MachXO5-NX devices can be re-booted from this new configuration file. If there is a problem, such as corrupt data during download or incorrect version number with this new boot image, the MachXO5-NX device can revert back to the original backup golden configuration and try again. This all can be done without power cycling the system. For more information, refer to [MachXO5-NX Programming and Configuration User Guide \(FPGA-TN-02271\)](#).

2.15. Single Event Upset (SEU) Support

MachXO5-NX devices are unique due to the underlying technology used to build these devices, and is much more robust and less prone to soft errors.

MachXO5-NX devices have an improved hardware implemented Soft Error Detection (SED) circuit that can be used to detect SRAM errors and thus allow the errors to be corrected. There are two layers of SED implemented in the MachXO5-NX device making it more robust and reliable.

The SED hardware in MachXO5-NX devices is part of the Configuration block. The SED module in the MachXO5-NX device is an enhanced version as compared to the SED modules implemented in other Lattice devices. The configuration data is divided into frames so that the entire FPGA can be programmed precisely with ease. The SED hardware reads data from the FPGAs configuration memory and performs Error Correcting Code (ECC) calculation on every frame of configuration data (see [Figure 2.1](#)). Once a single bit of error is detected, Soft Error Upset (SEU), a notification is generated and SED resumes operation. For single bit errors, the corrected value is rewritten to the particular frame using ECC information. If more than one-bit error is detected within one frame of configuration data, an error message is generated. MachXO5-NX devices also have a dedicated logic to perform Cycle Redundancy Code (CRC) checks. This CRC runs in parallel for the entire bitstream along with ECC.

After the ECC is calculated on all frames of configuration data, Cyclic Redundancy Check (CRC) is calculated for the entire configuration data (bitstream). The data that is read, and the ECC and CRC calculated, do not include EBR Big SRAM and distributed RAM memory.

For further information on SED support, refer to [Soft Error Detection \(SED\)/Correction \(SEC\) User Guide for Nexus Platform \(FPGA-TN-02076\)](#).

2.16. On-Chip Oscillator

The MachXO5-NX device features two different frequency Oscillators. One is tailored for low-power operation that runs at low frequency (LFOSC). Both Oscillators are controlled with the internally generated current.

The LFOSC runs at nominal frequency of 128 kHz. The high frequency oscillator (HFOSC) runs at a nominal frequency of 450 MHz, and is divisible from 2 to 256 for output frequency between 1.758 MHz (div256) and 225 MHz (div2). The LFOSC always run, thus can be used to perform all always-on functions with the possible lowest power.

2.17. User I²C IP

The MachXO5-NX device has one I²C IP core. The core can be configured either as an I²C master or as an I²C slave. The pins for the I²C interface are pre-assigned.

The core has the option to delay either the input or the output, or both, by 50 ns nominal, using dedicated on-chip delay elements. This provides an easier interface with any external I²C components. In addition, 50 ns glitch filters are available for both SDA and SCL.

When the IP core is configured as master, it can control other devices on the I²C bus through the pre-assigned pin interface. When the core is configured as the slave, the device can provide, for example, I/O expansion to an I²C Master. The I²C core supports the following functionalities:

- Master and Slave operation
- 7-bit and 10-bit addressing
- Multi-master arbitration support
- Clock stretching
- Up to 1 MHz data transfer speed (Standard-Mode, Fast-Mode, Fast-Mode Plus)
- General Call support
- Optional receive and transmit data FIFOs with programmable sizes
- Optionally 50 ns delay on input or output data, or both
- Hard-connection and Programmable I/O connection support
- Programmable to a mode compliant with I3C requirements on legacy I²C Slave devices
- Fast-Mode and Fast-Mode Plus support

- Disabled Clock Stretching
- 50 ns SCL and SDA Glitch Filter
- Programmable 7-bit address

For further information on the User I²C, refer to [I²C Hardened IP User Guide for Nexus Platform \(FPGA-TN-02142\)](#).

2.18. User Flash Memory (UFM)

MachXO5-NX devices provide a UFM block that can be used for a variety of applications including configuration image overflow, initializing EBRs to store PROM data or, as a general purpose user Flash memory. The UFM block connects to the device core through the embedded function block LMMI interface. You can also access the UFM block through the JTAG, I²C, and SPI interfaces of the device. The UFM block offers the following features:

- Non-volatile storage up to 15,360 kb
- Write access is performed page-wise; each page has 2048 bits (256 bytes)
- Auto-increment addressing
- LMMI interface

Table 2.14. UFM Size

Device	UFM0 (kbit)	UFM1 (kbit)	UFM2 (kbit)	User Data (kbit)
LFMXO5-25	2,048	2,048	2,048	9,216

2.19. Trace ID

Each MachXO5-NX device contains a unique (per device) TraceID that can be used for tracking purposes or for IP security applications. The TraceID is 64 bits long. Eight out of 64 bits are user-programmable, the remaining 56 bits are factory-programmed. The TraceID is accessible through the SPI, I²C, or JTAG interfaces. For further information on TraceID, refer to [Using TraceID \(FPGA-TN-02084\)](#).

2.20. Pin Migration

The MachXO5-NX family is designed to ensure that different density devices in the same family and in the same package have the same pinout. Furthermore, the architecture ensures a high success rate when performing design migration from lower density devices to higher density devices. In many cases, it is also possible to shift a lower utilization design targeted for a high-density device to a lower density device. However, the exact details of the final resource utilization impact the likelihood of success in each case. An example is that some user I/O may become No Connects in smaller devices in the same package. Refer to the MachXO5-NX Pin Migration Tables and Lattice Radiant software for specific restrictions and limitations.

2.21. Cryptographic Engine

The MachXO5-NX family of devices support several cryptographic features that helps customer secure their design. Some of the key cryptographic features include Advanced Encryption Standard (AES) and Hashing Algorithms and true random number generator (TRNG). The MachXO5-NX device also features the bitstream encryption (using AES-256) used for protecting confidential FPGA bitstream data, and the bitstream authentication (using ECDSA) maintaining the bitstream integrity and protecting the FPGA design bitstream from being copied and tampered.

The Cryptographic Engine (CRE) is the main engine (Figure 2.27) that is responsible for the bitstream encryption as well as the authentication of the MachXO5-NX device. Once the bitstream is authenticated and the device is ready for user functions, CRE is available for you to implement various cryptographic functions in your FPGA design. To enable specific cryptographic function, CRE must be configured by setting a few registers.

CRE supports the following user-mode features:

- True Random Number generator (TRNG)
- Secure Hashing Algorithm (SHA)-256 bit
- Message authentication codes (MACs) – HMAC
- Lattice Memory Mapped Interface (LMMI) interface to user logic
- High Speed Port (HSP) for FIFO-based streaming data transfer

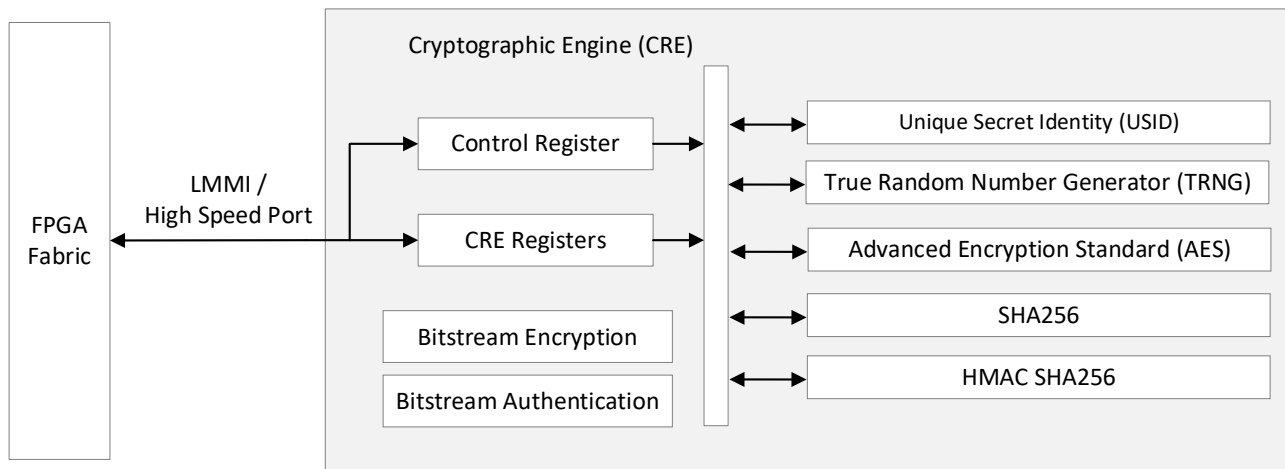

Figure 2.27. Cryptographic Engine Block Diagram

3. DC and Switching Characteristics for Commercial and Industrial

3.1. Absolute Maximum Ratings

Table 3.1. Absolute Maximum Ratings

Symbol	Parameter	Min	Max	Unit
$V_{CC}, V_{CCCECLK}$	Supply Voltage	-0.5	1.10	V
$V_{CCAUX}, V_{CCAUXA}, V_{CCAUXH5}, V_{CCAUXH6}$	Supply Voltage	-0.5	1.98	V
$V_{CCIO0, 1, 2, 3, 4, 7, 8, 9, 10, 11}$	I/O Supply Voltage	-0.5	3.63	V
$V_{CCIO5, 6}$	I/O Supply Voltage	-0.5	1.98	V
$V_{CCADC18}$	ADC Block 1.8 V Supply Voltage	-0.5	1.98	V
—	Input or I/O Voltage Applied, Bank 0, Bank 1, Bank 2, Bank 3, Bank 4, Bank 7, Bank 8, Bank 9	-0.5	3.63	V
—	Input or I/O Voltage Applied, Bank 5, Bank 6	-0.5	1.98	V
T_A	Storage Temperature (Ambient)	-65	150	°C
T_J	Junction Temperature	—	+125	°C

Notes:

- Stress above those listed under the *Absolute Maximum Ratings* may cause permanent damage to the device. Functional operation of the device at these or any other conditions above those indicated in the operational sections of this specification is not implied.
- Compliance with the Lattice [Thermal Management](#) document is required.
- All voltages referenced to GND.
- All V_{CCAUX} should be connected on PCB.

3.2. Recommended Operating Conditions^{1, 2, 3}

Table 3.2. Recommended Operating Conditions

Symbol	Parameter	Conditions	Min	Typ.	Max	Unit
V_{CC}, V_{CCECLK}	Core Supply Voltage	$V_{CC} = 1.0$	0.95	1.00	1.05	V
V_{CCAUX}	Auxiliary Supply Voltage	Bank 0, Bank 1, Bank 2, Bank 3, Bank 4, Bank 7, Bank 8, Bank 9	1.746	1.80	1.89	V
$V_{CCAUXH5/6}$	Auxiliary Supply Voltage	Bank 5, Bank 6	1.746	1.80	1.89	V
V_{CCAUXA}	Auxiliary Supply Voltage for core logic	—	1.746	1.80	1.89	V
V_{CCIO}	I/O Driver Supply Voltage	$V_{CCIO} = 3.3$ V, Bank 0, Bank 1, Bank 2, Bank 3, Bank 4, Bank 7, Bank 8, Bank 9	3.135	3.30	3.465	V
		$V_{CCIO} = 2.5$ V, Bank 0, Bank 2, Bank 3, Bank 4, Bank 7, Bank 8, Bank 9	2.375	2.50	2.625	V
		$V_{CCIO} = 1.8$ V, All Banks except Bank 1	1.71	1.80	1.89	V
		$V_{CCIO} = 1.5$ V, All Banks except Bank 1 ⁴	1.425	1.50	1.575	V
		$V_{CCIO} = 1.35$ V, All Banks except Bank 1 ⁴ (For DDR3L Only)	1.2825	1.35	1.4175	V
		$V_{CCIO} = 1.2$ V, All Banks except Bank 1 ⁴	1.14	1.20	1.26	V
		$V_{CCIO} = 1.0$ V, Bank 5, Bank 6	0.95	1.00	1.05	V
ADC External Power Supplies						
$V_{CCADC18}$	ADC 1.8 V Power Supply	—	1.71	1.80	1.89	V
Operating Temperature						
t_{JCOM}	Junction Temperature, Commercial Operation	—	0	—	85	°C
t_{JIND}	Junction Temperature, Industrial Operation	—	-40	—	100	°C

Notes:

1. For correct operation, all supplies must be held in their valid operation voltage range.
2. All supplies with same voltage should be from the same voltage source. Proper isolation filters are needed to properly isolate noise from each other.
3. Common supply rails must be tied together.
4. JTAG, SSPI, I²C, and I3C (Bank 2) ports are supported for $V_{CCIO} = 1.8$ V to 3.3 V.

3.3. Power Supply Ramp Rates

Table 3.3. Power Supply Ramp Rates

Symbol	Parameter	Min	Typ	Max	Unit
t_{RAMP}	Power Supply ramp rates for all supplies ¹	0.1	—	50	V/ms

Notes:

1. Assumes monotonic ramp rates.
2. All supplies need to be in the operating range as defined in [Recommended Operating Conditions](#) when the device has completed configuration and entering into User Mode. Supplies that are not in the operating range needs to be adjusted to faster ramp rate, or you have to delay configuration or wake up.

3.4. Power up Sequence

Power-On-Reset (POR) puts the MachXO5-NX device into a reset state. There is no power up sequence required for the MachXO5-NX device.

Table 3.4. Power-On Reset

Symbol	Parameter	Min	Typ	Max	Unit	
V_{PORUP}	Power-On-Reset ramp-up trip point (Monitoring V_{CC} , V_{CCAUX} , V_{CCIO1} , and V_{CCIO2})	V_{CC}	0.73	—	0.83	V
		V_{CCAUX}	1.34	—	1.62	V
		V_{CCIO1}, V_{CCIO2}	0.89	—	1.05	V
V_{PORDN}	Power-On-Reset ramp-up trip point (Monitoring V_{CC} and V_{CCAUX})	V_{CC}	0.51	—	0.81	V
		V_{CCAUX}	1.38	—	1.59	V

3.5. On-Chip Programmable Termination

The MachXO5-NX devices support a variety of programmable on-chip terminations options, including:

- Dynamically switchable Single-Ended Termination with programmable resistor values of 40 Ω , 50 Ω , 60 Ω , or 75 Ω .
- Common mode termination of 100 Ω for differential inputs.

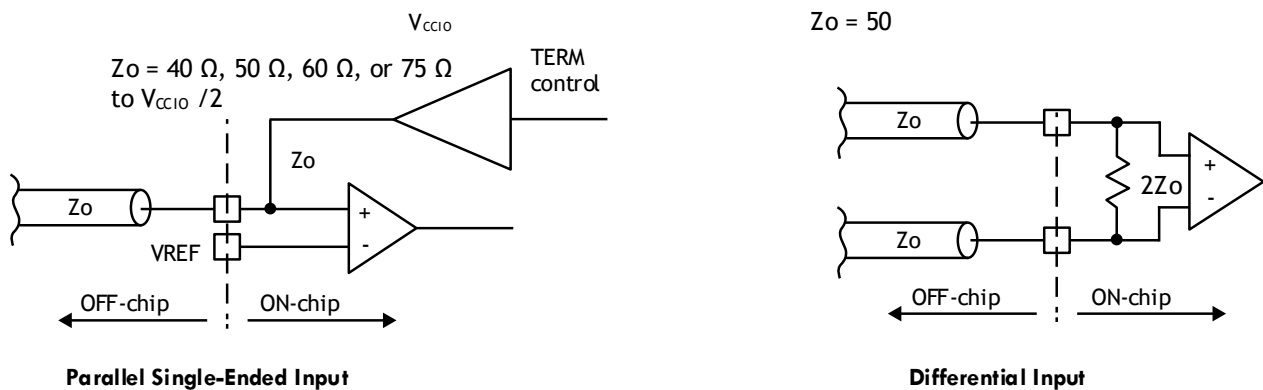

Figure 3.1. On-Chip Termination

See [Table 3.5](#) for termination options for input modes.

Table 3.5. On-Chip Termination Options for Input Modes

IO_TYPE	Differential Termination Resistor ^{1,2}	Terminate to $V_{CCIO}/2$ ^{1,2}
subLVDS	100, OFF	OFF
SLVS	100, OFF	OFF
MIPI_DPHY	100	OFF
HSTL15D_I	100, OFF	OFF

IO_TYPE	Differential Termination Resistor ^{1, 2}	Terminate to V _{CCIO} /2 ^{1, 2}
SSTL15D_I	100, OFF	OFF
SSTL135D_I	100, OFF	OFF
HSUL12D	100, OFF	OFF
LVC MOS15H	OFF	OFF
LVC MOS12H	OFF	OFF
LVC MOS10H	OFF	OFF
LVC MOS12H	OFF	OFF
LVC MOS10H	OFF	OFF
LVC MOS18H	OFF	OFF, 40, 50, 60, 75
HSTL15_I	OFF	50
SSTL15_I	OFF	OFF, 40, 50, 60, 75
SSTL135_I	OFF	OFF, 40, 50, 60, 75
HSUL12	OFF	OFF, 40, 50, 60, 75

Notes:

1. TERMINATE to V_{CCIO}/2 (Single-Ended) and DIFFERENTIAL TERMINATION RESISTOR when turned on can only have one setting per bank. Only bottom bank have this feature.
2. Use of TERMINATE to V_{CCIO}/2 and DIFFERENTIAL TERMINATION RESISTOR are mutually exclusive in an I/O bank. On-chip termination tolerance -10%/+60%.

Refer to [sys/O User Guide for Nexus Platform \(FPGA-TN-02067\)](#) for on-chip termination usage and value ranges.

3.6. Hot Socketing Specifications

Table 3.6. Hot Socketing Specifications for GPIO

Symbol	Parameter	Condition	Min	Typ	Max	Unit
I _{DK}	Input or I/O Leakage Current for Wide Range I/O (excluding INITN/DONE)	0 < V _{IN} < V _{IH} (max) 0 < V _{CC} < V _{CC} (max) 0 < V _{CCIO} < V _{CCIO} (max) 0 < V _{CCAUX} < V _{CCAUX} (max)	-1.5	—	1.5	mA

Notes:

- I_{DK} is additive to I_{PU}, I_{PD}, or I_{BH}.
- Hot socket specification defines when the hot socketed device's junction temperature is at 85 °C or below. When the hot socketed device's junction temperature is above 85 °C, the I_{DK} current can exceed the above spec.
- Going beyond the hot socketing ranges specified here will cause exponentially higher Leakage currents and potential reliability issues. A total of 64 mA per eight I/O should not be exceeded.

3.7. Programming /Erase Specifications

Table 3.7. Programming/Erase Specifications

Symbol	Parameter	Min	Max.	Units
N _{PROG} CYC	Flash Programming cycles per t _{RETENTION}	—	10,000	Cycles
	Flash Write /Erase cycles	—	100,000	
t _{RETENTION}	Data retention at 100 °C junction temperature	20	—	Years
	Data retention at 85 °C junction temperature	>20	—	

Note:

A Write/Erase cycle is defined as any number of writes over time followed by one erase cycle.

3.8. ESD Performance

Refer to the MachXO5-NX Product Family Qualification Summary for complete qualification data, including ESD performance.

3.9. DC Electrical Characteristics

Table 3.8. DC Electrical Characteristics – Wide Range (Over Recommended Operating Conditions)

Symbol	Parameter	Condition	Min	Typ	Max	Unit
I_{IL}, I_{IH}^1	Input or I/O Leakage current (Commercial/Industrial)	$0 \leq V_{IN} \leq V_{CCIO}$	—	—	10	μA
I_{IH}^2	Input or I/O Leakage current	$V_{CCIO} \leq V_{IN} \leq V_{IH} (max)$	—	—	100	μA
I_{PU}	I/O Weak Pull-up Resistor Current	$0 \leq V_{IN} \leq 0.7 \times V_{CCIO}$	-30	—	-150	μA
I_{PD}	I/O Weak Pull-down Resistor Current	$V_{IL} (max) \leq V_{IN} \leq V_{CCIO}$	30	—	150	μA
I_{BHLS}	Bus Hold Low Sustaining Current	$V_{IN} = V_{IL} (max)$	30	—	—	μA
I_{BHHS}	Bus Hold High Sustaining Current	$V_{IN} = 0.7 \times V_{CCIO}$	-30	—	—	μA
I_{BHLO}	Bus hold low Overdrive Current	$0 \leq V_{IN} \leq V_{CCIO}$	—	—	150	μA
I_{BHHO}	Bus hold high Overdrive Current	$0 \leq V_{IN} \leq V_{CCIO}$	—	—	-150	μA
V_{BHT}	Bus Hold Trip Points	—	$V_{IL} (max)$	—	$V_{IH} (min)$	V

Notes:

- Input or I/O leakage current is measured with the pin configured as an input or as an I/O with the output tri-stated. Bus Maintenance circuits are disabled.
- The input leakage current I_{IH} is the worst case input leakage per GPIO when the pad signal is high and also higher than the bank V_{CCIO} . This is considered a mixed mode input.

Table 3.9. DC Electrical Characteristics – High Speed (Over Recommended Operating Conditions)

Symbol	Parameter	Condition	Min	Typ	Max	Unit
I_{IL}, I_{IH}^1	Input or I/O Leakage	$0 \leq V_{IN} \leq V_{CCIO}$	—	—	10	μA
I_{PU}	I/O Weak Pull-up Resistor Current	$0 \leq V_{IN} \leq 0.7 \times V_{CCIO}$	-30	—	-150	μA
I_{PD}	I/O Weak Pull-down Resistor Current	$V_{IL} (max) \leq V_{IN} \leq V_{CCIO}$	30	—	150	μA
I_{BHLS}	Bus Hold Low Sustaining Current	$V_{IN} = V_{IL} (max)$	30	—	—	μA
I_{BHHS}	Bus Hold High Sustaining Current	$V_{IN} = 0.7 \times V_{CCIO}$	-30	—	—	μA
I_{BHLO}	Bus hold low Overdrive Current	$0 \leq V_{IN} \leq V_{CCIO}$	—	—	150	μA
I_{BHHO}	Bus hold high Overdrive Current	$0 \leq V_{IN} \leq V_{CCIO}$	—	—	-150	μA
V_{BHT}	Bus Hold Trip Points	—	$V_{IL} (max)$	—	$V_{IH} (min)$	V

Note:

- Input or I/O leakage current is measured with the pin configured as an input or as an I/O with the output tri-stated. Bus Maintenance circuits are disabled.

Table 3.10. Capacitors – Wide Range (Over Recommended Operating Conditions)

Symbol	Parameter	Condition	Min	Typ	Max	Unit
C_1^1	I/O Capacitance	$V_{CCIO} = 3.3 V, 2.5 V, 1.8 V, 1.5 V, 1.2 V, V_{CC} = typ., V_{IO} = 0 \text{ to } V_{CCIO} + 0.2 V$	—	6	—	pf
C_2^1	Dedicated Input Capacitance	$V_{CCIO} = 3.3 V, 2.5 V, 1.8 V, 1.5 V, 1.2 V, V_{CC} = typ., V_{IO} = 0 \text{ to } V_{CCIO} + 0.2 V$	—	6	—	pf

Note:

- $T_A = 25^\circ C, f = 1.0 \text{ MHz}$.

Table 3.11. Capacitors – High Performance (Over Recommended Operating Conditions)

Symbol	Parameter	Condition	Min	Typ	Max	Unit
C ₁ ¹	I/O Capacitance	V _{CCIO} = 1.8 V, 1.5 V, 1.2 V, V _{CC} = typ., V _{IO} = 0 to V _{CCIO} + 0.2 V	—	6	—	pf
C ₂ ¹	Dedicated Input Capacitance	V _{CCIO} = 1.8 V, 1.5 V, 1.2 V, V _{CC} = typ., V _{IO} = 0 to V _{CCIO} + 0.2 V	—	6	—	pf

Note:

1. T_A 25 °C, f = 1.0 MHz.

Table 3.12. Single Ended Input Hysteresis – Wide Range (Over Recommended Operating Conditions)

IO_TYPE	V _{CCIO}	TYP Hysteresis
LVC MOS33	3.3 V	250 mV
LVC MOS25	3.3 V	200 mV
	2.5 V	250 mV
LVC MOS18	1.8 V	180 mV
LVC MOS15	1.5 V	50 mV
LVC MOS12	1.2 V	0
LVC MOS10	1.2 V	0

Table 3.13. Single Ended Input Hysteresis – High Performance (Over Recommended Operating Conditions)

IO_TYPE	V _{CCIO}	TYP Hysteresis
LVC MOS18H	1.8 V	180 mV
LVC MOS15H	1.8 V	50 mV
	1.5 V	150 mV
LVC MOS12H	1.2 V	0
LVC MOS10H	1.0 V	0
MIPI-LP-RX	1.2 V	>25 mV

3.10. Supply Currents

For estimating and calculating current, use Power Calculator in Lattice Design Software.

This operating and peak current is design dependent, and can be calculated in Lattice Design Software. Some blocks can be placed into low current standby modes. Refer to [Power Management and Calculation for Certus-NX, CertusPro-NX, and MachXO5-NX Devices \(FPGA-TN-02257\)](#).

3.11. sysI/O Recommended Operating Conditions

Table 3.14. sysI/O Recommended Operating Conditions

Standard	Support Banks	V _{CCIO} (Input)	V _{CCIO} (Output)
		Typ.	Typ.
Single-Ended			
LVC MOS33	0, 1, 2, 3, 4, 7, 8, 9	3.3	3.3
LV TTL33	0, 1, 2, 3, 4, 7, 8, 9	3.3	3.3
LVC MOS25 ^{1, 2}	0, 1, 2, 3, 4, 7, 8, 9	2.5, 3.3	2.5
LVC MOS18 ^{1, 2}	0, 2, 3, 4, 7, 8, 9	1.2, 1.5, 1.8, 2.5, 3.3	1.8
LVC MOS18H	5, 6	1.8	1.8
LVC MOS15 ^{1, 2}	0, 2, 3, 4, 7, 8, 9	1.2, 1.5, 1.8, 2.5, 3.3	1.5
LVC MOS15H ¹	5, 6	1.5, 1.8	1.5

Standard	Support Banks	V _{CCIO} (Input)	V _{CCIO} (Output)
		Typ.	Typ.
LVC MOS12 ^{1, 2}	0, 2, 3, 4, 7, 8, 9	1.2, 1.5, 1.8, 2.5, 3.3	1.2
LVC MOS12H ¹	5, 6	1.2, 1.35 ⁷ , 1.5, 1.8	1.2
LVC MOS10 ¹	0, 2, 3, 4, 7, 8, 9	1.2, 1.5, 1.8, 2.5, 3.3	—
LVC MOS10H ¹	5, 6	1.0, 1.2, 1.35 ⁷ , 1.5, 1.8	1.0
LVC MOS10R ¹	5, 6	1.0, 1.2, 1.35 ⁷ , 1.5, 1.8	—
SSTL135_I, SSTL135_II ³	5, 6	1.35 ⁷	1.35
SSTL15_I, SSTL15_II ³	5, 6	1.5 ⁸	1.5 ⁸
HSTL15_I ³	5, 6	1.5 ⁸	1.5 ⁸
HSUL12 ³	5, 6	1.2	1.2
MIPI D-PHY LP Input ⁶	5, 6	1.2	1.2
Differential			
LVDS	5, 6	1.2, 1.35, 1.5, 1.8	1.8
LVDSE ⁵	0, 2, 3, 4, 7, 8, 9	—	2.5
subLVDS	5, 6	1.2, 1.35, 1.5, 1.8	—
subLVDSE ⁵	0, 2, 3, 4, 7, 8, 9	—	1.8
subLVDSEH ⁵	5, 6	—	1.8
SLVS ⁶	5, 6	1.0, 1.2, 1.35 ⁷ , 1.5, 1.8 ⁴	1.2, 1.35 ⁷ , 1.5, 1.8 ⁴
MIPI D-PHY ⁶	5, 6	1.2	1.2
LVC MOS33D ⁵	0, 1, 2, 3, 4, 7, 8, 9	—	3.3
LVTTL33D ⁵	0, 1, 2, 3, 4, 7, 8, 9	—	3.3
LVC MOS25D ⁵	0, 2, 3, 4, 7, 8, 9	—	2.5
SSTL135D_I, SSTL135D_II ⁵	5, 6	—	1.35 ⁷
SSTL15D_I, SSTL15D_II ⁵	5, 6	—	1.5
HSTL15D_I ⁵	5, 6	—	1.5
HSUL12D ⁵	5, 6	—	1.2

Notes:

- Single-ended input can mix into I/O Banks with V_{CCIO} different from the standard requires due to some of these input standards use internal supply voltage source (V_{CC}, V_{CCAUX}) to power the input buffer, which makes them to be independent of V_{CCIO} voltage. For more details, please refer to [sys/O User Guide for Nexus Platform \(FPGA-TN-02067\)](#). The following is a brief guideline to follow:
 - Weak pull-up on the I/O must be set to OFF.
 - Bank 5 and Bank 6 I/O can only mix into banks with V_{CCIO} higher than the pin standard, due to clamping diode on the pin in these banks. Bank 0, Bank 1, Bank 2, Bank 3, Bank 4, Bank 7, Bank 8 and Bank 9 does not have this restriction.
 - LVC MOS25 uses V_{CCIO} supply on input buffer in Bank 0, Bank 1, Bank 2, Bank 3, Bank 4, Bank 7, Bank 8 and Bank 9. It can be supported with V_{CCIO} = 3.3 V to meet the V_{IH} and V_{IL} requirements, but there is additional current drawn on V_{CCIO}. Hysteresis has to be disabled when using 3.3 V supply voltage.
 - LVC MOS15 uses V_{CCIO} supply on input buffer in Bank 5 and Bank 6. It can be supported with V_{CCIO} = 1.8 V to meet the V_{IH} and V_{IL} requirements, but there is additional current drawn on V_{CCIO}.
- Single-ended LVC MOS inputs can mixed into I/O Banks with different V_{CCIO}, providing weak pull-up is not used. For additional information on Mixed I/O in Bank V_{CCIO}, refer to [sys/O User Guide for Nexus Platform \(FPGA-TN-02067\)](#).
- These inputs use differential input comparator in Bank 5 and Bank 6. The differential input comparator uses V_{CCAUXH} power supply. These inputs require the V_{REF} pin to provide the reference voltage in the Bank. Refer to [sys/O User Guide for Nexus Platform \(FPGA-TN-02067\)](#) for details.
- All differential inputs use differential input comparator in Bank 5 and Bank 6. The differential input comparator uses V_{CCAUXH} power supply. There is no differential input signaling supported in Bank 0, Bank 1, Bank 2, Bank 3, Bank 4, Bank 7, Bank 8 and Bank 9.
- These outputs are emulating differential output pair with single-ended output drivers with true and complement outputs driving on each of the corresponding true and complement output pair pins. The common mode voltage, V_{CM}, is ½ × V_{CCIO}. Refer to [sys/O User Guide for Nexus Platform \(FPGA-TN-02067\)](#) for details.
- Soft MIPI D-PHY HS using sys/O is supported with SLVS input and output that can be placed in banks with V_{CCIO} voltage shown in SLVS. D-PHY with HS and LP modes supported needs to be placed in banks with V_{CCIO} voltage = 1.2 V. Soft MIPI D-PHY LP input and output using sys/O are supported with LVC MOS12.

7. $V_{CCIO} = 1.35\text{ V}$ is only supported in Bank 5 and Bank 6, for use with DDR3L interface in the bank. These Input and Output standards can fit into the same bank with the $V_{CCIO} = 1.35\text{ V}$.
8. LVCMOS15 input uses V_{CCIO} supply voltage. If V_{CCIO} is 1.8 V, the DC levels for LVCMOS15 are still met, but there could be increase in input buffer current.

3.12. sysI/O Single-Ended DC Electrical Characteristics³

Table 3.15. sysI/O DC Electrical Characteristics – Wide Range I/O (Over Recommended Operating Conditions)

Input/Output Standard	V_{IL}^1		V_{IH}^1		$V_{OL}\text{ Max (V)}$	$V_{OH}\text{ Min}^2\text{ (V)}$	$I_{OL}\text{(mA)}$	$I_{OH}\text{(mA)}$
	Min (V)	Max (V)	Min (V)	Max (V)				
LVTTTL33 LVCMOS33	—	0.8	2.0	3.465 ⁵	0.4	$V_{CCIO} - 0.4$	4, 8, 12, "50RS" ³	-4, -8, -12, "50RS" ³
	—	0.8	2.0	3.465 ⁵	0.4	2.4	2	-2
	—	0.8	2.0	3.465 ⁵	0.49	$V_{CCIO} - 0.58$	16	-16
LVCMOS25	—	0.7	1.7	3.465 ⁵	0.4	$V_{CCIO} - 0.45$	2, 4, 8, 10, "50RS" ³	-2, -4, -8, -10, "50RS" ³
LVCMOS18	—	$0.35 \times V_{CCIO}$	$0.65 \times V_{CCIO}$	3.465 ⁵	0.4	$V_{CCIO} - 0.45$	2, 4, 8, "50RS" ³	-2, -4, -8, "50RS" ³
LVCMOS15	—	$0.35 \times V_{CCIO}$	$0.65 \times V_{CCIO}$	3.465 ⁵	0.4	$V_{CCIO} - 0.4$	2, 4	-2, -4
LVCMOS12	—	$0.35 \times V_{CCIO}$	$0.65 \times V_{CCIO}$	3.465 ⁵	0.4	$V_{CCIO} - 0.4$	2, 4	-2, -4
LVCMOS10	—	$0.35 \times V_{CCIO}$	$0.65 \times V_{CCIO}$	3.465 ⁵	No O/P Support			

Notes:

1. V_{CCIO} for input level refers to the supply rail level associated with a given input standard.
2. V_{CCIO} for the output levels refer to the V_{CCIO} of the CertusPro-NX device.
3. Selecting "50RS" in driver strength is to select 50 Ω series impedance driver.
4. For electro-migration, the combined DC current sourced or sinked by I/O pads between two consecutive V_{CCIO} or GND pad connections, or between the last V_{CCIO} or GND in an I/O bank and the end of an I/O bank, as shown in the Logic Signal Connections table (also shown as I/O grouping) shall not exceed a maximum of $n \times 8\text{ mA}$. n is the number of I/O pads between the two consecutive bank V_{CCIO} or GND connections or between the last V_{CCIO} and GND in a bank and the end of a bank. I/O Grouping can be found in the Data Sheet Pin Summary Tables, which can also be generated from the Lattice Radiant software.
5. If the input clamp is OFF, $V_{IH}\text{ (Max)}$ in Banks 0, 1, 2, 3, 4, 7, 8, and 9 can go up to 3.465 V. Otherwise, the input voltage cannot be higher than $V_{CCIO} + 0.3\text{ V}$.

Table 3.16. sysI/O DC Electrical Characteristics – High Performance I/O (Over Recommended Operating Conditions)³

Input/Output Standard	V _{IL} ¹		V _{IH} ¹		V _{OL} Max (V)	V _{OH} Min ² (V)	I _{OL} (mA)	I _{OH} (mA)
	Min (V)	Max (V)	Min (V)	Max (V)				
LVCMOS18H	—	0.35 × V _{CCIO}	0.65 × V _{CCIO}	V _{CCIO} + 0.3	0.4	V _{CCIO} – 0.45	2, 4, 8, 12	-2, -4, -8, -12
	—	0.35 × V _{CCIO}	0.65 × V _{CCIO}	V _{CCIO} + 0.3	0.4	V _{CCIO} – 0.53	“50RS” ³	“50RS” ³
LVCMS15H	—	0.35 × V _{CCIO}	0.65 × V _{CCIO}	V _{CCIO} + 0.3	0.4	V _{CCIO} – 0.4	2, 4, 8	-2, -4, -8
LVCMS12H	—	0.35 × V _{CCIO}	0.65 × V _{CCIO}	V _{CCIO} + 0.3	0.4	V _{CCIO} – 0.4	2, 4, 8	-2, -4, -8
LVCMOS10H	—	0.35 × V _{CCIO}	0.65 × V _{CCIO}	V _{CCIO} + 0.3	0.27 × V _{CCIO}	0.64 × V _{CCIO}	2	-2
	—	0.35 × V _{CCIO}	0.65 × V _{CCIO}	V _{CCIO} + 0.3	0.27 × V _{CCIO}	0.75 × V _{CCIO}	4	-4
SSTL15_I	—	V _{REF} – 0.10	V _{REF} + 0.1	V _{CCIO} + 0.3	0.30	V _{CCIO} – 0.30	7.5	-7.5
SSTL15_II	—	V _{REF} – 0.10	V _{REF} + 0.1	V _{CCIO} + 0.3	0.30	V _{CCIO} – 0.30	8.8	-8.8
HSTL15_I	—	V _{REF} – 0.10	V _{REF} + 0.16	V _{CCIO} + 0.3	0.40	V _{CCIO} – 0.40	8	-8
SSTL135_I	—	V _{REF} – 0.09	V _{REF} + 0.09	V _{CCIO} + 0.3	0.27	V _{CCIO} – 0.27	6.75	-6.75
SSTL135_II	—	V _{REF} – 0.09	V _{REF} + 0.09	V _{CCIO} + 0.3	0.27	V _{CCIO} – 0.27	8	-8
LVCMS10R	—	V _{REF} – 0.10	V _{REF} + 0.10	V _{CCIO} + 0.3	—	—	—	—
HSUL12	—	V _{REF} – 0.10	V _{REF} + 0.10	V _{CCIO} + 0.3	0.3	V _{CCIO} – 0.3	8.0, 7.5, 6.25, 5	-8.0, -7.5, -6.25, -5

Notes:

1. V_{CCIO} for input level refers to the supply rail level associated with a given input standard or the upstream driver V_{CCIO} rail levels.
2. V_{CCIO} for the output levels refer to the V_{CCIO} of the MachXO5-NX device.
3. Select “50RS” in driver strength is selecting the 50Ω series impedance driver.
4. For electro-migration, the combined DC current sourced or sunk by I/O pads between two consecutive V_{CCIO} or GND pad connections, or between the last V_{CCIO} or GND in an I/O bank and the end of an I/O bank, as shown in the Logic Signal Connections table (also shown as I/O grouping) shall not exceed a maximum of n × 8 mA. n is the number of I/O pads between the two consecutive bank V_{CCIO} or GND connections or between the last V_{CCIO} and GND in a bank and the end of a bank. I/O Grouping can be found in the Data Sheet Pin Summary Tables, which can also be generated from the Lattice Radiant software.

Table 3.17. I/O Resistance Characteristics (Over Recommended Operating Conditions)

Parameter	Description	Test Conditions	Min	Typ	Max	Unit
50RS	Output Drive Resistance when 50RS Drive Strength Selected	V _{CCIO} = 1.8 V, 2.5 V, or 3.3 V	—	50	—	Ω
R _{DIFF}	Input Differential Termination Resistance	Bank 5 and Bank 6 for I/O selected to be differential	—	100	—	Ω
SE Input Termination	Input Single Ended Termination Resistance	Bank 5 and Bank 6 for I/O selected to be Single Ended	36	40	64	Ω
			46	50	80	
			56	60	96	
			65	75	120	

Table 3.18. V_{IN} Maximum Overshoot/Undershoot Allowance – Wide Range^{1,2}

AC Voltage Overshoot	% of UI at –40 °C to 100 °C	AC Voltage Undershoot	% of UI at –40 °C to 100 °C
V _{CCIO} + 0.4	100.0%	–0.4	100.0%
V _{CCIO} + 0.5	100.0%	–0.5	44.2%
V _{CCIO} + 0.6	94.0%	–0.6	10.1%
V _{CCIO} + 0.7	21.0%	–0.7	1.3%
V _{CCIO} + 0.8	10.2%	–0.8	0.3%
V _{CCIO} + 0.9	2.5%	–0.9	0.1%

Notes:

1. The peak overshoot or undershoot voltage and the duration above V_{CCIO} + 0.2 V or below GND – 0.2 V must not exceed the values in this table.
2. For UI less than 20 μs.

Table 3.19. V_{IN} Maximum Overshoot/Undershoot Allowance – High Performance^{1,2}

AC Voltage Overshoot	% of UI at –40 °C to 100 °C	AC Voltage Undershoot	% of UI at –40 °C to 100 °C
V _{CCIO} + 0.5	100.0%	–0.5	100.0%
V _{CCIO} + 0.6	47.3%	–0.6	47.3%
V _{CCIO} + 0.7	10.9%	–0.7	10.9%
V _{CCIO} + 0.8	2.7%	–0.8	2.7%
V _{CCIO} + 0.9	0.7%	–0.9	0.7%

Notes:

1. The peak overshoot or undershoot voltage and the duration above V_{CCIO} + 0.2 V or below GND – 0.2 V must not exceed the values in this table.
2. For UI less than 20 μs.

3.13. sysI/O Differential DC Electrical Characteristics

3.13.1. LVDS

LVDS input buffer on MachXO5-NX is powered by $V_{CCAUX} = 1.8\text{ V}$, and protected by the bank V_{CCIO} . Therefore, the LVDS input voltage cannot exceed the bank V_{CCIO} voltage. LVDS output buffer is powered by the Bank V_{CCIO} at 1.8 V.

LVDS can only be supported in Bank 5 and Bank 6. LVDS25 output can be emulated with LVDS25E in Bank 0, Bank 1, Bank 2, Bank 3, Bank 4, Bank 7, Bank 8 and Bank 9. This is described in [LVDS25E \(Output Only\)](#) section.

Table 3.20. LVDS DC Electrical Characteristics (Over Recommended Operating Conditions)¹

Parameter	Description	Test Conditions	Min	Typ	Max	Unit
V_{INP}, V_{INM}	Input Voltage	—	0	—	1.60 ³	V
V_{ICM}	Input Common Mode Voltage	Half the sum of the two Inputs	0.05	—	1.55 ²	V
V_{THD}	Differential Input Threshold	Difference between the two Inputs	±100	—	—	mV
I_{IN}	Input Current	Power On or Power Off	—	—	±10	µA
V_{OH}	Output High Voltage for V_{OP} or V_{OM}	$R_T = 100\ \Omega$	—	1.425	1.60	V
V_{OL}	Output Low Voltage for V_{OP} or V_{OM}	$R_T = 100\ \Omega$	0.9	1.075	—	V
V_{OD}	Output Voltage Differential	$(V_{OP} - V_{OM}), R_T = 100\ \Omega$	250	350	450	mV
ΔV_{OD}	Change in V_{OD} Between High and Low	—	—	—	50	mV
V_{OCM}	Output Common Mode Voltage	$(V_{OP} + V_{OM})/2, R_T = 100\ \Omega$	1.125	1.25	1.375	V
ΔV_{OCM}	Change in $V_{OCM}, V_{OCM(MAX)} - V_{OCM(MIN)}$	—	—	—	50	mV
I_{SAB}	Output Short Circuit Current	$V_{OD} = 0\text{ V}$ Driver outputs shorted to each other	—	—	12	mA
ΔV_{OS}	Change in V_{OS} between H and L	—	—	—	50	mV

Notes:

1. LVDS input or output are supported in Bank 3, Bank 4, and Bank 5. LVDS input uses V_{CCAUX} on the differential input comparator, and can be located in any V_{CCIO} voltage bank. LVDS output uses V_{CCIO} on the differential output driver, and can only be located in bank with $V_{CCIO} = 1.8\text{ V}$.
2. V_{ICM} is depending on V_{ID} , input differential voltage, so the voltage on pin cannot exceed $V_{INP/INM(min/max)}$ requirements. $V_{ICM(min)} = V_{INP/INM(min)} + \frac{1}{2} V_{ID}$, $V_{ICM(max)} = V_{INP/INM(max)} - \frac{1}{2} V_{ID}$. Values in the table is based on minimum V_{ID} of +/- 100 mV.
3. V_{INP} and $V_{INM(max)}$ must be less than or equal to V_{CCIO} in all cases.

3.13.2. LVDS25E (Output Only)

Three sides of the MachXO5-NX devices, Top, Left and Right, support LVDS25 outputs with emulated complementary LVCMOS outputs in conjunction with a parallel resistor across the driver outputs. The scheme shown in [Figure 3.2](#) is one possible solution for point-to-point signals.

Table 3.21. LVDS25E DC Conditions

Parameter	Description	Typical	Unit
V_{CCIO}	Output Driver Supply (±5%)	2.50	V
Z_{OUT}	Driver Impedance	20	Ω
R_S	Driver Series Resistor (±1%)	158	Ω
R_P	Driver Parallel Resistor (±1%)	140	Ω
R_T	Receiver Termination (±1%)	100	Ω
V_{OH}	Output High Voltage	1.43	V
V_{OL}	Output Low Voltage	1.07	V
V_{OD}	Output Differential Voltage	0.35	V
V_{CM}	Output Common Mode Voltage	1.25	V
Z_{BACK}	Back Impedance	100.5	Ω
I_{DC}	DC Output Current	6.03	mA

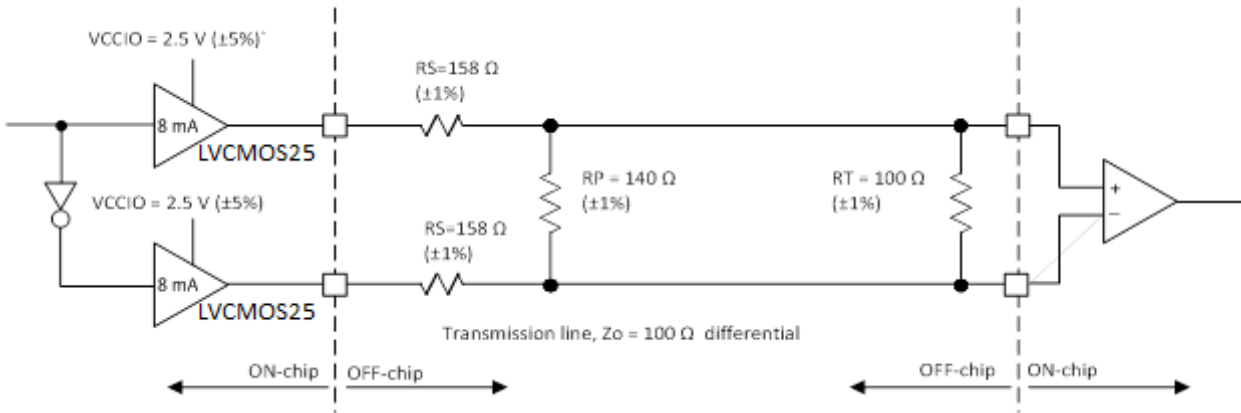

Figure 3.2. LVDS25E Output Termination Example

3.13.3. SubLVDS (Input Only)

SubLVDS is a reduced-voltage form of LVDS signaling, very similar to LVDS. It is a standard used in many camera types of applications, and follow the [SMIA 1.0, Part 2: CCP2 Specification](#). Similar to LVDS, the MachXO5-NX devices can support the subLVDS input signaling with the same LVDS input buffer. The output for subLVDS is implemented in subLVDS/subLVDSSEH with a pair of LVC MOS18 output drivers. See [SubLVDS/subLVDSSEH \(Output Only\)](#) section.

Table 3.22. SubLVDS Input DC Electrical Characteristics (Over Recommended Operating Conditions)

Parameter	Description	Test Conditions	Min	Typ	Max	Unit
V_{ID}	Input Differential Threshold Voltage	Over V_{ICM} range	70	150	200	mV
V_{ICM}	Input Common Mode Voltage	Half the sum of the two Inputs	0.4	0.9	1.4 ¹	V

Note:

- $V_{ICM} + 1/2 V_{ID}$ cannot exceed the bank V_{CCIO} in all cases.

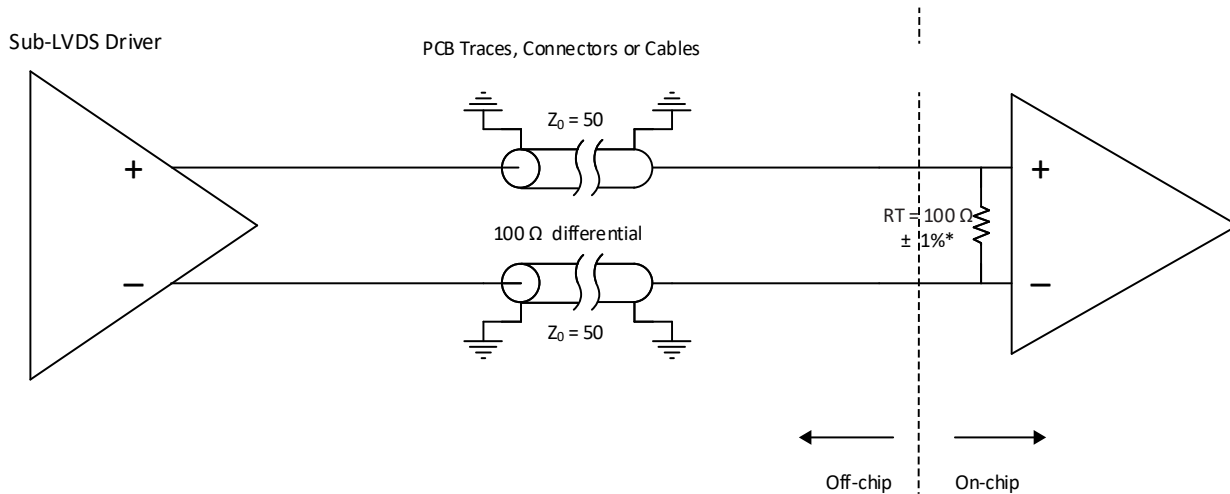

Figure 3.3. SubLVDS Input Interface

3.13.4. SubLVDS/SubLVDS (Output Only)

SubLVDS output uses a pair of LVCMOS18 drivers with True and Complement outputs. The V_{CCIO} of the bank used for subLVDS or subLVDS needs to be powered by 1.8 V. SubLVDS is for Bank 0, Bank 1, Bank 2, Bank 3, Bank 4, Bank 7, Bank 8 and Bank 9; and subLVDS is for Bank 5 and Bank 6.

Performance of the subLVDS/subLVDS driver is limited to the performance of LVCMOS18.

Table 3.23. SubLVDS Output DC Electrical Characteristics (Over Recommended Operating Conditions)

Parameter	Description	Test Conditions	Min	Typ	Max	Unit
V_{OD}	Output Differential Voltage Swing	—	—	150	—	mV
V_{OCM}	Output Common Mode Voltage	Half the sum of the two Outputs	—	0.9	—	V

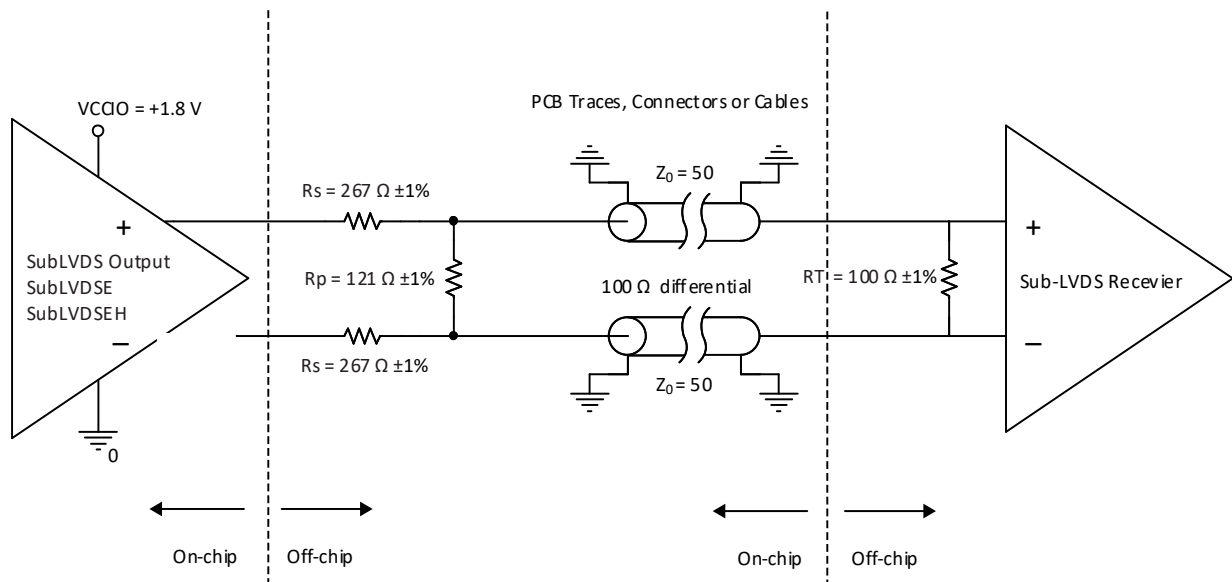

Figure 3.4. SubLVDS Output Interface

3.13.5. SLVS

Scalable Low-Voltage Signaling (SLVS) is based on a point-to-point signaling method defined in the JEDEC JESD8-13 (SLVS-400) standard. This standard evolved from the traditional LVDS standard with smaller voltage swings and a lower common-mode voltage. The 200 mV (400 mV p-p) SLVS swing contributes to a reduction in power.

The MachXO5-NX devices receive SLVS differential input with the LVDS input buffer. This LVDS input buffer is designed to cover wide input common mode range that can meet the SLVS input standard specified by the JEDEC standard.

Table 3.24. SLVS Input DC Characteristics (Over Recommended Operating Conditions)

Parameter	Description	Test Conditions	Min	Typ	Max	Unit
V_{ID}	Input Differential Threshold Voltage	Over V_{ICM} range	70	—	—	mV
V_{ICM}	Input Common Mode Voltage	Half the sum of the two Inputs	70	200	330	mV

The SLVS output on the MachXO5-NX device is supported with the LVDS drivers found in Bank 5 and Bank 6. The LVDS driver on the MachXO5-NX device is a current controlled driver. It can be configured as LVDS driver, or configured with the 100 Ω differential termination with center-tap set to V_{OCM} at 200 mV. This means the differential output driver can be placed into bank with $V_{CCIO} = 1.2$ V, 1.5 V, or 1.8 V, even if it is powered by V_{CCIO} .

Table 3.25. SLVS Output DC Characteristics (Over Recommended Operating Conditions)

Parameter	Description	Test Conditions	Min	Typ	Max	Unit
V_{CCIO}	Bank V_{CCIO}	—	-5%	1.2, 1.5, 1.8	+5%	V
V_{OD}	Output Differential Voltage Swing	—	140	200	270	mV
V_{OCM}	Output Common Mode Voltage	Half the sum of the two Outputs	150	200	250	mV
Z_{OS}	Single-Ended Output Impedance	—	37.5	50	62.5	Ω

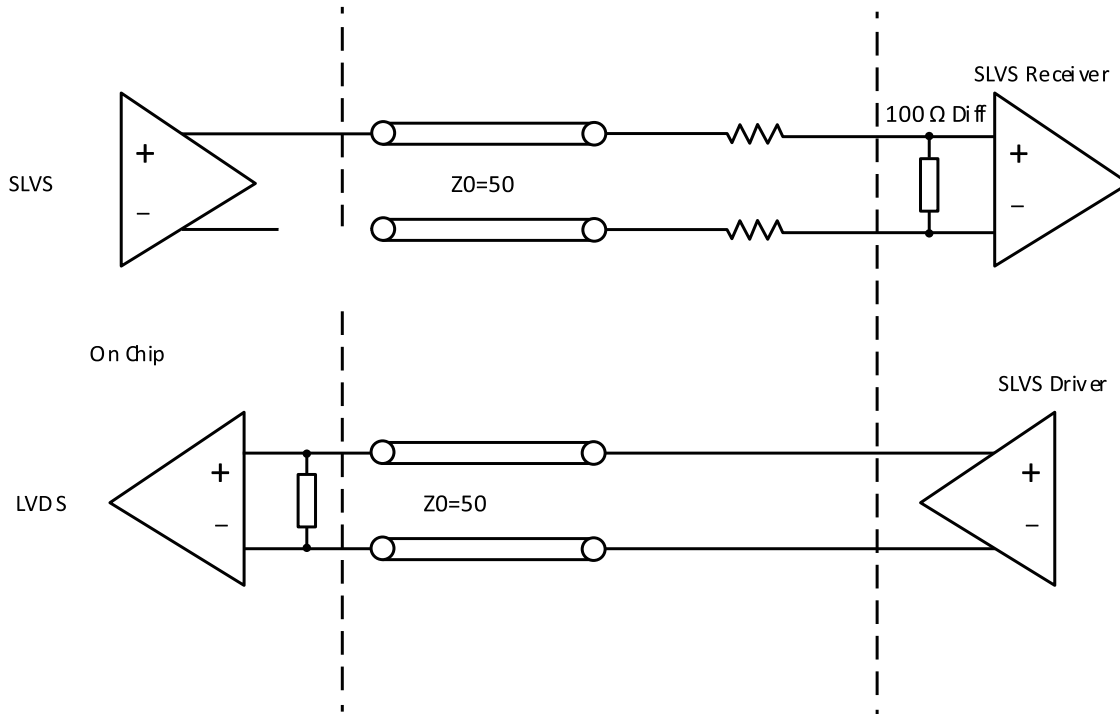

Figure 3.5. SLVS Interface

3.13.6. Soft MIPI D-PHY

When Soft D-PHY is implemented inside the FPGA logic, the I/O interface needs to use sysI/O buffers to connect to external D-PHY pins.

The MachXO5-NX sysI/O provides support of SLVS, as described in [SLVS](#) section, plus the LVCMOS12 input / output buffers together to support the High Speed (HS) and Low Power (LP) mode as defined in MIPI Alliance Specification for D-PHY.

To support MIPI D-PHY with SLVS (LVDS) and LVCMOS12, the bank V_{CCIO} cannot be set to 1.5 V or 1.8 V. It has to connect to 1.2 V, or 1.1 V.

All other DC parameters are the same as those listed in [SLVS](#) section. DC parameters for the LP driver and receiver are the same as those listed in LVCMOS12.

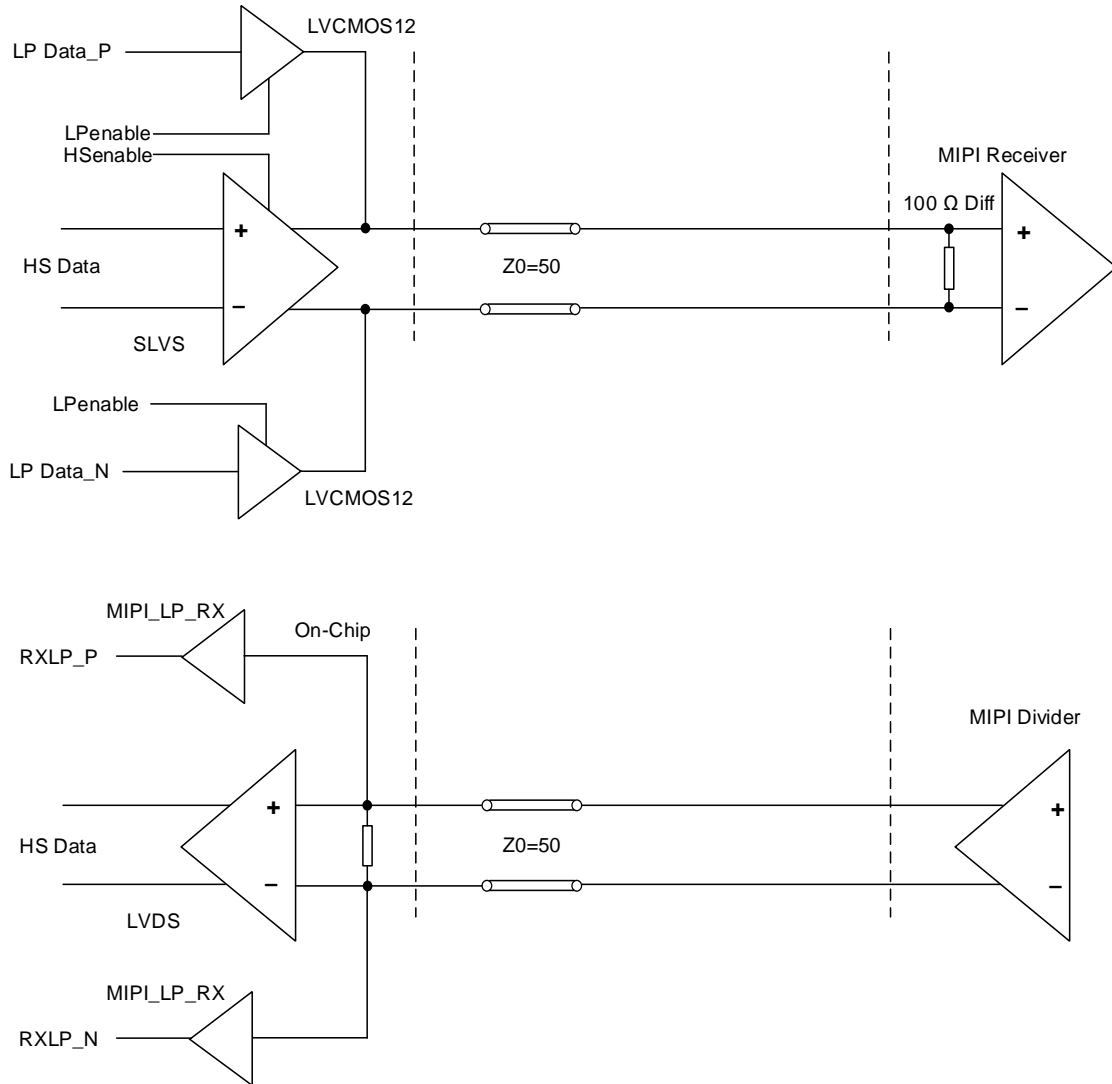

Figure 3.6. MIPI Interface

Table 3.26. Soft D-PHY Input Timing and Levels

Symbol	Description	Conditions	Min	Typ	Max	Unit
High Speed (Differential) Input DC Specifications						
V _{CMRX(DC)}	Common-mode Voltage in High Speed Mode	—	70	—	330	mV
V _{IDTH}	Differential Input HIGH Threshold	—	70	—	—	mV
V _{IDTL}	Differential Input LOW Threshold	—	—	—	-70	mV
V _{IHHS}	Input HIGH Voltage (for HS mode)	—	—	—	460	mV
V _{ILHS}	Input LOW Voltage	—	-40	—	—	mV
V _{TERM-EN}	Single-ended voltage for HS Termination Enable ⁴	—	—	—	450	mV
Z _D	Differential Input Impedance	—	80	100	125	Ω
High Speed (Differential) Input AC Specifications						
ΔV _{CMRX(HF)} ¹	Common-mode Interference (>450 MHz)	—	—	—	100	mV
ΔV _{CMRX(LF)} ^{2, 3}	Common-mode Interference (50 MHz – 450 MHz)	—	-50	—	50	mV
C _{CM}	Common-mode Termination	—	—	—	60	pF
Low Power (Single-Ended) Input DC Specifications						
V _{IH}	Low Power Mode Input HIGH Voltage	—	740	—	—	mV
V _{IL}	Low Power Mode Input LOW Voltage	—	—	—	480	mV
V _{IL-ULP}	Ultra Low Power Input LOW Voltage	—	—	—	300	mV
V _{HYST}	Low Power Mode Input Hysteresis	—	25	—	—	mV
e _{SPIKE}	Input Pulse Rejection	—	—	—	300	V·ps
T _{MIN-RX}	Minimum Pulse Width Response	—	20	—	—	ns
V _{INT}	Peak Interference Amplitude	—	—	—	200	mV
f _{INT}	Interference Frequency	—	450	—	—	MHz

Notes:

1. This is peak amplitude of sine wave modulated to the receiver inputs.
2. Input common-mode voltage difference compared to average common-mode voltage on the receiver inputs.
3. Exclude any static ground shift of 50 mV.
4. High Speed Differential R_{TERM} is enabled when both D_P and D_N are below this voltage.

Table 3.27. Soft D-PHY Output Timing and Levels

Symbol	Description	Conditions	Min	Typ	Max	Unit
High Speed (Differential) Output DC Specifications						
V _{CMTX}	Common-mode Voltage in High Speed Mode	—	150	200	250	mV
ΔV _{CMTX(1,0)}	V _{CMTX} Mismatch Between Differential HIGH and LOW	—	—	—	7	mV
V _{OD}	Output Differential Voltage	D-PHY-P – D-PHY-N	140	200	270	mV
ΔV _{OD}	V _{OD} Mismatch Between Differential HIGH and LOW	—	—	—	25	mV
V _{OHHS}	Single-Ended Output HIGH Voltage	—	—	—	410	mV
Z _{OS}	Single Ended Output Impedance	—	37.5	50	80	Ω
ΔZ _{OS}	Z _{OS} mismatch	—	—	—	20	%
High Speed (Differential) Output AC Specifications						
ΔV _{CMTX(LF)}	Common-Mode Variation, 50 MHz–450 MHz	—	—	—	25	mV _{RMS}
ΔV _{CMTX(HF)}	Common-Mode Variation, above 450 MHz	—	—	—	15	mV _{RMS}
t _R	Output 20%–80% Rise Time Output 80%–20% Fall Time	0.08 Gbps ≤ t _R ≤ 1.00 Gbps	—	—	0.30	UI
		1.00 Gbps < t _R ≤ 1.25 Gbps	—	—	0.434	UI
t _F	Output Data Valid After CLK Output	0.08 Gbps ≤ t _F ≤ 1.00 Gbps	—	—	0.30	UI
		1.00 Gbps < t _F ≤ 1.25 Gbps	—	—	0.419	UI
Low Power (Single-Ended) Output DC Specifications						
V _{OH}	Low Power Mode Output HIGH Voltage	0.08 Gbps – 1.25 Gbps	1.07	1.2	1.3	V
V _{OL}	Low Power Mode Input LOW Voltage	—	–50	—	50	mV
Z _{OLP}	Output Impedance in Low Power Mode	—	110	—	—	Ω
Low Power (Single-Ended) Output AC Specifications						
t _{RLP}	15%–85% Rise Time	—	—	—	25	ns
t _{FLP}	85%–15% Fall Time	—	—	—	25	ns
t _{REOT}	HS – LP Mode Rise and Fall Time, 30%–85%	—	—	—	35	ns
T _{LP-PULSE-TX}	Pulse Width of the LP Exclusive-OR Clock	First LP XOR Clock Pulse after STOP State or Last Pulse before STOP State	40	—	—	ns
		All Other Pulses	20	—	—	ns
T _{LP-PER-TX}	Period of the LP Exclusive-OR Clock	—	90	—	—	ns
C _{LOAD}	Load Capacitance	—	0	—	70	pF

Table 3.28. Soft D-PHY Clock Signal Specification

Symbol	Description	Conditions	Min	Typ	Max	Unit
Clock Signal Specification						
UI Instantaneous	U _{IINST}	—	—	—	12.5	ns
UI Variation	ΔUI	—	–10%	—	10%	UI
		—	–5%	—	5%	UI

Table 3.29. Soft D-PHY Data-Clock Timing Specifications

Symbol	Description	Conditions	Min	Typ	Max	Unit
Data-Clock Timing Specifications						
T _{SKEW[TX]}	Data to Clock Skew	0.08 Gbps ≤ T _{SKEW[TX]} ≤ 1.00 Gbps	-0.15	—	0.15	UI _{INST}
		1.00 Gbps < T _{SKEW[TX]} ≤ 1.25 Gbps	-0.20	—	0.20	UI _{INST}
T _{SKEW[TLIS]}	Data to Clock Skew	0.08 Gbps ≤ T _{SKEW[TLIS]} ≤ 1.00 Gbps	-0.20	—	0.20	UI _{INST}
		1.00 Gbps < T _{SKEW[TLIS]} ≤ 1.25 Gbps	-0.10	—	0.10	UI _{INST}
T _{SETUP[RX]}	Input Data Setup Before CLK	0.08 Gbps ≤ T _{SETUP[RX]} ≤ 1.00 Gbps	0.15	—	—	UI
		1.00 Gbps < T _{SETUP[RX]} ≤ 1.25 Gbps	0.20	—	—	UI
T _{HOLD[RX]}	Input Data Hold After CLK	0.08 Gbps ≤ T _{HOLD[RX]} ≤ 1.00 Gbps	0.15	—	—	UI
		1.00 Gbps < T _{HOLD[RX]} ≤ 1.25 Gbps	0.20	—	—	UI

3.13.7. Differential HSTL15D (Output Only)

Differential HSTL outputs are implemented as a pair of complementary single-ended HSTL outputs.

3.13.8. Differential SSTL135D, SSTL15D (Output Only)

Differential SSTL is used for differential clock in DDR3/DDR3L memory interface. All differential SSTL outputs are implemented as a pair of complementary single-ended SSTL outputs. All allowable single-ended output classes (class I and class II) are supported.

3.13.9. Differential HSUL12D (Output Only)

Differential HSUL is used for differential clock in LPDDR2/LPDDR3 memory interface. All differential HSUL outputs are implemented as a pair of complementary single-ended HSUL12 outputs. All allowable single-ended drive strengths are supported.

3.13.10. Differential LVCMOS25D, LVCMOS33D, LVTTTL33D (Output Only)

Differential LVCMOS and LVTTTL outputs are implemented as a pair of complementary single-ended outputs. All allowable single-ended output drive strengths are supported.

3.14. Maximum sysI/O Buffer Speed

Over recommended operating conditions.

Table 3.30. Maximum I/O Buffer Speed^{1, 2, 3, 4, 7}

Buffer	Description	Banks	Max	Unit
Maximum sysI/O Input Frequency				
Single-Ended				
LVC MOS33	LVC MOS33, V _{CCIO} = 3.3 V	0, 1, 2, 3, 4, 7, 8, 9	200	MHz
LV TTL33	LV TTL33, V _{CCIO} = 3.3 V	0, 1, 2, 3, 4, 7, 8, 9	200	MHz
LVC MOS25	LVC MOS25, V _{CCIO} = 2.5 V	0, 1, 2, 3, 4, 7, 8, 9	200	MHz
LVC MOS18 ⁵	LVC MOS18, V _{CCIO} = 1.8 V	0, 2, 3, 4, 7, 8, 9	200	MHz
LVC MOS18H	LVC MOS18, V _{CCIO} = 1.8 V	5, 6	200	MHz
LVC MOS15 ⁵	LVC MOS15, V _{CCIO} = 1.5 V	0, 2, 3, 4, 7, 8, 9	100	MHz
LVC MOS15H ⁵	LVC MOS15, V _{CCIO} = 1.5 V	5, 6	150	MHz
LVC MOS12 ⁵	LVC MOS12, V _{CCIO} = 1.2 V	0, 2, 3, 4, 7, 8, 9	50	MHz
LVC MOS12H ⁵	LVC MOS12, V _{CCIO} = 1.2 V	5, 6	100	MHz
LVC MOS10 ⁵	LVC MOS 1.0, V _{CCIO} = 1.2 V	0, 2, 3, 4, 7, 8, 9	50	MHz
LVC MOS10H ⁵	LVC MOS 1.0, V _{CCIO} = 1.0 V	5, 6	50	MHz
LVC MOS10R	LVC MOS 1.0, V _{CCIO} independent	5, 6	50	MHz
SSTL15_I, SSTL15_II	SSTL_15, V _{CCIO} = 1.5 V	5, 6	1066	Mbps
SSTL135_I, SSTL135_II	SSTL_135, V _{CCIO} = 1.35 V	5, 6	1066	Mbps
HSUL12	HSUL_12, V _{CCIO} = 1.2 V	5, 6	1066	Mbps
HSTL15	HSTL15, V _{CCIO} = 1.5 V	5, 6	250	Mbps
MIPI D-PHY (LP Mode)	MIPI, Low Power Mode, V _{CCIO} = 1.2 V	5, 6	10	Mbps
Differential⁸				
LVDS	LVDS, V _{CCIO} independent	5, 6	1250	Mbps
subLVDS	subLVDS, V _{CCIO} independent	5, 6	1250	Mbps
SLVS	SLVS similar to MIPI HS, V _{CCIO} independent	5, 6	1250	Mbps
MIPI D-PHY (HS Mode)	MIPI, High Speed Mode, V _{CCIO} = 1.2 V	5, 6	1250	Mbps
SSTL15D	Differential SSTL15, V _{CCIO} independent	5, 6	1066	Mbps
SSTL135D	Differential SSTL135, V _{CCIO} independent	5, 6	1066	Mbps
HSUL12D	Differential HSUL12, V _{CCIO} independent	5, 6	1066	Mbps
HSTL15D	Differential HSTL15, V _{CCIO} independent	5, 6	250	Mbps
Maximum sysI/O Output Frequency				
Single-Ended				
LVC MOS33 (all drive strengths)	LVC MOS33, V _{CCIO} = 3.3 V	0, 1, 2, 3, 4, 7, 8, 9	200	MHz
LVC MOS33 (RS50)	LVC MOS33, V _{CCIO} = 3.3 V, R _{SERIES} = 50 Ω	0, 1, 2, 3, 4, 7, 8, 9	200	MHz
LV TTL33 (all drive strengths)	LV TTL33, V _{CCIO} = 3.3 V	0, 1, 2, 3, 4, 7, 8, 9	200	MHz
LV TTL33 (RS50)	LV TTL33, V _{CCIO} = 3.3 V, R _{SERIES} = 50 Ω	0, 1, 2, 3, 4, 7, 8, 9	200	MHz
LVC MOS25 (all drive strengths)	LVC MOS25, V _{CCIO} = 2.5 V	0, 2, 3, 4, 7, 8, 9	200	MHz
LVC MOS25 (RS50)	LVC MOS25, V _{CCIO} = 2.5 V, R _{SERIES} = 50 Ω	0, 2, 3, 4, 7, 8, 9	200	MHz
LVC MOS18 (all drive strengths)	LVC MOS18, V _{CCIO} = 1.8 V	0, 2, 3, 4, 7, 8, 9	200	MHz
LVC MOS18 (RS50)	LVC MOS18, V _{CCIO} = 1.8 V, R _{SERIES} = 50 Ω	0, 2, 3, 4, 7, 8, 9	200	MHz
LVC MOS18H (all drive strengths)	LVC MOS18, V _{CCIO} = 1.8 V	5, 6	200	MHz
LVC MOS18H (RS50)	LVC MOS18, V _{CCIO} = 1.8 V, R _{SERIES} = 50 Ω	5, 6	200	MHz
LVC MOS15 (all drive strengths)	LVC MOS15, V _{CCIO} = 1.5 V	0, 2, 3, 4, 7, 8, 9	100	MHz
LVC MOS15H (all drive strengths)	LVC MOS15, V _{CCIO} = 1.5 V	5, 6	150	MHz
LVC MOS12 (all drive strengths)	LVC MOS12, V _{CCIO} = 1.2 V	0, 2, 3, 4, 7, 8, 9	50	MHz

Buffer	Description	Banks	Max	Unit
LVC MOS12H (all drive strengths)	LVC MOS12, $V_{CCIO} = 1.2\text{ V}$	5, 6	100	MHz
LVC MOS10H (all drive strengths)	LVC MOS12, $V_{CCIO} = 1.2\text{ V}$	5, 6	50	MHz
SSTL15_I, SSTL15_II	SSTL_15, $V_{CCIO} = 1.5\text{ V}$	5, 6	1066	Mbps
SSTL135_I, SSTL135_II	SSTL_135, $V_{CCIO} = 1.35\text{ V}$	5, 6	1066	Mbps
HSUL12 (all drive strengths)	HSUL_12, $V_{CCIO} = 1.2\text{ V}$	5, 6	1066	Mbps
HSTL15	HSTL15, $V_{CCIO} = 1.5\text{ V}$	5, 6	250	Mbps
MIPI D-PHY (LP Mode)	MIPI, Low Power Mode, $V_{CCIO} = 1.2\text{ V}$	5, 6	10	Mbps
Differential⁸				
LVDS	LVDS, $V_{CCIO} = 1.8\text{ V}$	5, 6	1250	Mbps
LVDS25E ⁶	LVDS25, Emulated, $V_{CCIO} = 2.5\text{ V}$	0, 2, 3, 4, 7, 8, 9	400	Mbps
SubLVDS E ⁶	subLVDS, Emulated, $V_{CCIO} = 1.8\text{ V}$	0, 2, 3, 4, 7, 8, 9	400	Mbps
SubLVDS E H ⁶	subLVDS, Emulated, $V_{CCIO} = 1.8\text{ V}$	5, 6	800	Mbps
SLVS	SLVS similar to MIPI, $V_{CCIO} = 1.2\text{ V}$	5, 6	1250	Mbps
MIPI D-PHY (HS Mode)	MIPI, High Speed Mode, $V_{CCIO} = 1.2\text{ V}$	5, 6	1250	Mbps
SSTL15D	Differential SSTL15, $V_{CCIO} = 1.5\text{ V}$	5, 6	1066	Mbps
SSTL135D	Differential SSTL135, $V_{CCIO} = 1.35\text{ V}$	5, 6	1066	Mbps
HSUL12D	Differential HSUL12, $V_{CCIO} = 1.2\text{ V}$	5, 6	1066	Mbps
HSTL15D	Differential HSTL15, $V_{CCIO} = 1.5\text{ V}$	5, 6	250	Mbps

Notes:

- Maximum I/O speed is the maximum switching rate of the I/O operating within the guidelines of the defining standard. The actual interface speed performance using the I/O also depends on other factors, such as internal and external timing.
- These numbers are characterized but not test on every device.
- Performance is specified in MHz, as defined in clock rate when the sysI/O is used as pin. For data rate performance, this can be converted to Mbps, which equals to 2 times the clock rate.
- LVC MOS and LV TTL are measured with load specified in [Table 3.46](#).
- These LVC MOS inputs can be placed in different V_{CCIO} voltage. Performance may vary. Please refer to Lattice Design Software
- These emulated outputs performance is based on externally properly terminated as described in [LVDS25E \(Output Only\)](#) and [SubLVDS E/SubLVDS E H \(Output Only\)](#).
- All speeds are measured with fast slew.
- For maximum differential I/O performance, only Differential I/O should be placed in the bottom I/O banks. If this is not possible, the following will impact on maximum performance:
 - If Fast Slew Rate LVC MOS I/O are used, they should be limited to no more than nine I/O (adjacent), four I/O (same bank), 55 I/O (left/right banks) to keep degradation below 50%.
 - If non-Differential I/O (SLOW SLEW) are placed on the bottom but not within the same bank as differential I/O, then the maximum Differential performance is degraded to 70% of original when 21 aggressors are toggling.
 - If non-Differential I/O (SLOW SLEW) are placed within the same bank as Differential I/O then the maximum performance is degraded to 50% of original when 16 aggressor are toggling.
 - No performance impact if MIPI LP and MIPI HS are in the same bank.
 - If Differential RX/TX I/O are both placed within the same bank then the maximum performance is degraded to 90%.
 - For DDR3/3L, LPDDR2/3 separate DQ/DQS groups from Address/Commands/CLK groups into separate banks.

3.15. Typical Building Block Function Performance

These building block functions can be generated using Lattice Design Software Tool. Exact performance may vary with the device and the design software tool version. The design software tool uses internal parameters that have been characterized but are not tested on every device.

Table 3.31. Pin-to-Pin Performance

Function	Typ. @ V _{CC} = 1.0 V	Unit
16-bit Decoder (I/O configured with LVCMOS18, Top, Left and Right Banks)	5.5	ns
16-bit Decoder (I/O configured with HSTL15_I, Bottom Banks)	5.1	ns
16:1 Mux (I/O configured with LVCMOS18, Top, Left and Right Banks)	6	ns
16:1 Mux (I/O configured with HSTL15_I, Bottom Banks)	6.1	ns

Note: These functions are generated using Lattice Radiant Design Software tool. Exact performance may vary with the device and the design software tool version. The design software tool uses internal parameters that have been characterized but are not tested on every device.

Table 3.32. Register-to-Register Performance^{1, 3, 4}

Function	Typ. @ V _{CC} = 1.0 V	Unit
Basic Functions		
16-bit Adder	500 ²	MHz
32-bit Adder	496	MHz
16-bit Counter	402	MHz
32-bit Counter	371	MHz
Embedded Memory Functions		
512 × 36 Single Port RAM, with Output Register	500 ²	MHz
1024 × 18 True-Dual Port RAM using same clock, with EBR Output Registers	500 ²	MHz
1024 × 18 True-Dual Port RAM using asynchronous clocks, with EBR Output Registers	500 ²	MHz
Large Memory Functions		
32 k × 32 Single Port RAM, with Output Register	375 ²	MHz
32 k × 32 Single Port RAM with ECC, with Output Register	350 ²	MHz
32 k × 32 True-Dual Port RAM using same clock, with Output Registers	200	MHz
Distributed Memory Functions		
16 × 4 Single Port RAM (One PFU)	500 ²	MHz
16 × 2 Pseudo-Dual Port RAM (One PFU)	500 ²	MHz
16 × 4 Pseudo-Dual Port (Two PFUs)	500 ²	MHz
DSP Functions		
9 × 9 Multiplier with Input Output Registers	376	MHz
18 × 18 Multiplier with Input/Output Registers	287	MHz
36 × 36 Multiplier with Input/Output Registers	200	MHz
MAC 18 × 18 with Input/Output Registers	203	MHz
MAC 18 × 18 with Input/Pipelined/Output Registers	287	MHz
MAC 36 × 36 with Input/Output Registers	119	MHz
MAC 36 × 36 with Input/Pipelined/Output Registers	155	MHz

Notes:

1. The Clock port is configured with LVDS I/O type. Performance Grade: 9_High-Performance_1.0V.
2. Limited by the Minimum Pulse Width of the component
3. These functions are generated using Lattice Radiant Design Software tool. Exact performance may vary with the device and the design software tool version. The design software tool uses internal parameters that have been characterized but are not tested on every device.
4. For the Pipelined designs, the number of pipeline stages used are 2.

3.16. LMMI

Table 3.33 summarizes the performance of the LMMI interface with supported IPs. Additional timing requirement and constraint can be identified through the Lattice Radiance design tools.

Table 3.33. LMMI F_{MAX} Summary

IP	F _{MAX} (MHz)
CDR0	73
CDR1	70
CRE	54
I ² C	38
PLL_ULC	59
PLL_LRC	37

3.17. Derating Timing Tables

Logic timing provided in the following sections of this data sheet and the Lattice Radiant design tools are worst case numbers in the operating range. Actual delays at nominal temperature and voltage for best case process, can be much better than the values given in the tables. The Lattice Radiant design tool can provide logic timing numbers at a particular temperature and voltage.

3.18. External Switching Characteristics

Over recommended commercial operating conditions.

Table 3.34. External Switching Characteristics (V_{CC} = 1.0 V)

Parameter	Description	-9		-8		-7		Unit
		Min	Max	Min	Max	Min	Max	
Clocks								
Primary Clock								
f _{MAX_PRI}	Frequency for Primary Clock	—	400	—	325.2	—	276	MHz
t _{W_PRI}	Clock Pulse Width for Primary Clock	1.125	—	1.384	—	1.630	—	ns
t _{SKEW_PRI} ⁶	Primary Clock Skew Within a Device	—	450	—	554	—	653	ps
Edge Clock								
f _{MAX_EDGE}	Frequency for Edge Clock Tree	—	800	—	650.4	—	551.7	MHz
t _{W_EDGE}	Clock Pulse Width for Edge Clock	0.537	—	0.661	—	0.779	—	ns
t _{SKEW_EDGE} ⁶	Edge Clock Skew Within a Device	—	120	—	148	—	174	ps
Generic SDR Input								
General I/O Pin Parameters Using Dedicated Primary Clock Input without PLL								
t _{CO}	Clock to Output – PIO Output Register	—	8.36	—	8.53	—	8.67	ns
t _{SU}	Clock to Data Setup – PIO Input Register	0.00	—	0.00	—	0.00	—	ns
t _{H(LTR)}	Clock to Data Hold – PIO Input Register	3.73	—	3.83	—	3.93	—	ns
t _{H(Bottom)}	Clock to Data Hold – PIO Input Register	4.65	—	4.75	—	4.84	—	ns

Parameter	Description	-9		-8		-7		Unit
		Min	Max	Min	Max	Min	Max	
t _{SU_DEL}	Clock to Data Setup – PIO Input Register with Data Input Delay	1.84	—	1.84	—	1.84	—	ns
t _{H_DEL(LTR)}	Clock to Data Hold – PIO Input Register with Data Input Delay	0.22	—	0.22	—	0.22	—	ns
t _{H_DEL(Bottom)}	Clock to Data Hold – PIO Input Register with Data Input Delay	1.77	—	1.77	—	1.77	—	ns
General I/O Pin Parameters Using Dedicated Primary Clock Input with PLL								
t _{COPLL}	Clock to Output – PIO Output Register	—	4.55	—	4.67	—	5.51	ns
t _{SUPLL(LTR except Bank1)}	Clock to Data Setup – PIO Input Register	1.71	—	1.71	—	1.71	—	ns
t _{SUPLL(Bank1)}	Clock to Data Setup – PIO Input Register	2.33	—	2.33	—	2.33	—	ns
t _{SUPLL(Bottom)}	Clock to Data Setup – PIO Input Register	1.33	—	1.33	—	1.33	—	ns
t _{HPLL(LTR)}	Clock to Data Hold – PIO Input Register	0.98	—	1.21	—	1.42	—	ns
t _{HPLL(Bottom)}	Clock to Data Hold – PIO Input Register	1.87	—	1.87	—	1.87	—	ns
t _{SU_DELPLL(LTR except Bank1)}	Clock to Data Setup – PIO Input Register with Data Input Delay	4.87	—	4.87	—	4.87	—	ns
t _{SU_DELPLL(Bank 1)}	Clock to Data Setup – PIO Input Register with Data Input Delay	5.77	—	5.77	—	5.77	—	ns
t _{SU_DELPLL(Bottom)}	Clock to Data Setup – PIO Input Register with Data Input Delay	4.74	—	4.74	—	4.74	—	ns
t _{H_DELPLL}	Clock to Data Hold – PIO Input Register with Data Input Delay	0.00	—	0.00	—	0.00	—	ns
Generic DDR Input/Output								
Generic DDRX1 Inputs/Outputs with Clock and Data Centered at Pin (GDDR1_RX/TX.SCLK.Centered) using PCLK Clock Input – Figure 3.7 and Figure 3.9 Left, Top and Right								
t _{SU_GDDR1}	Input Data Setup Before CLK	0.917	—	0.917	—	0.917	—	ns
		0.275	—	0.275	—	0.275	—	UI
t _{HO_GDDR1}	Input Data Hold After CLK	0.917	—	0.917	—	0.917	—	ns
t _{DVB_GDDR1}	Output Data Valid After CLK Output	1.217	—	1.113	—	1.014	—	ns
		-0.45	—	-0.554	—	-0.653	—	ns + 1/2 UI
t _{DQVA_GDDR1}	Output Data Valid After CLK Output	1.217	—	1.113	—	1.014	—	ns
		-0.45	—	-0.554	—	-0.653	—	ns + 1/2 UI
f _{DATA_GDDR1}	Input/Output Data Rate	—	300	—	300	—	300	Mbps
f _{MAX_GDDR1}	Frequency of PCLK	—	150	—	150	—	150	MHz
½ UI	Half of Data Bit Time, or 90 degree	1.667	—	1.667	—	1.667	—	ns
Output TX to Input RX Margin per Edge		0.3	—	0.197	—	0.097	—	ns
Generic DDRX1 Inputs/Outputs with Clock and Data Aligned at Pin (GDDR1_RX/TX.SCLK.Aligned) using PCLK Clock Input – Figure 3.8 and Figure 3.10 Left, Top and Right								

Parameter	Description	-9		-8		-7		Unit
		Min	Max	Min	Max	Min	Max	
t _{DVA_GDDR1}	Input Data Valid After CLK	—	-0.917	—	-0.917	—	-0.917	ns + 1/2 UI
		—	0.75	—	0.75	—	0.75	ns
		—	0.225	—	0.225	—	0.225	UI
t _{DVE_GDDR1}	Input Data Hold After CLK	0.917	—	0.917	—	0.917	—	ns + 1/2 UI
		2.583	—	2.583	—	2.583	—	ns
		0.775	—	0.775	—	0.775	—	UI
t _{DIA_GDDR1}	Output Data Invalid After CLK Output	—	0.45	—	0.554	—	0.653	ns
t _{DIB_GDDR1}	Output Data Invalid Before CLK Output	—	0.45	—	0.554	—	0.653	ns
f _{DATA_GDDR1}	Input/Output Data Rate	—	300	—	300	—	300	Mbps
f _{MAX_GDDR1}	Frequency for PCLK	—	150	—	150	—	150	MHz
½ UI	Half of Data Bit Time, or 90 degree	1.667	—	1.667	—	1.667	—	ns
Output TX to Input RX Margin per Edge		0.3	—	0.197	—	0.098	—	ns
Generic DDRX1 Inputs/Outputs with Clock and Data Centered at Pin (GDDR1_RX/TX.SCLK.Centered) using PCLK Clock Input – Figure 3.7 and Figure 3.9 Bottom								
t _{SU_GDDR1}	Input Data Setup Before CLK	0.55	—	0.55	—	0.648	—	ns
		0.275	—	0.275	—	0.275	—	UI
t _{HO_GDDR1}	Input Data Hold After CLK	0.55	—	0.55	—	0.648	—	ns
t _{DVB_GDDR1}	Output Data Valid After CLK Output	0.7	—	0.631	—	0.744	—	ns
		-0.300	—	-0.369	—	-0.435	—	ns + 1/2 UI
t _{DQVA_GDDR1}	Output Data Valid After CLK Output	0.7	—	0.631	—	0.744	—	ns
		-0.300	—	-0.369	—	-0.435	—	ns + 1/2 UI
f _{DATA_GDDR1}	Input/Output Data Rate	—	500	—	500	—	424	Mbps
f _{MAX_GDDR1}	Frequency of PCLK	—	250	—	250	—	212	MHz
½ UI	Half of Data Bit Time, or 90 degree	—	—	1	—	1.179	—	ns
Output TX to Input RX Margin per Edge		0.15	—	0.081	—	0.095	—	ns
Generic DDRX1 Inputs/Outputs with Clock and Data Aligned at Pin (GDDR1_RX/TX.SCLK.Aligned) using PCLK Clock Input – Figure 3.8 and Figure 3.10 Bottom								
t _{DVA_GDDR1}	Input Data Valid After CLK	—	-0.55	—	-0.550	—	-0.648	ns + 1/2 UI
		—	0.45	—	0.45	—	0.53	ns
		—	0.225	—	0.225	—	0.225	UI
t _{DVE_GDDR1}	Input Data Hold After CLK	0.55	—	0.55	—	0.648	—	ns + 1/2 UI
		1.55	—	1.55	—	1.827	—	ns
		0.775	—	0.775	—	0.775	—	UI
t _{DIA_GDDR1}	Output Data Invalid After CLK Output	—	0.3	—	0.369	—	0.435	ns
t _{DIB_GDDR1}	Output Data Invalid Before CLK Output	—	0.3	—	0.369	—	0.435	ns
f _{DATA_GDDR1}	Input/Output Data Rate	—	500	—	500	—	424	Mbps
f _{MAX_GDDR1}	Frequency for PCLK	—	250	—	250	—	212	MHz
½ UI	Half of Data Bit Time, or 90 degree	1	—	1	—	1.179	—	ns

Parameter	Description	-9		-8		-7		Unit
		Min	Max	Min	Max	Min	Max	
Output TX to Input RX Margin per Edge		0.15	—	0.081	—	0.095	—	ns
Generic DDRX2 Inputs/Outputs with Clock and Data Centered at Pin (GDDR2_RX/TX.ECLK.Centered) using PCLK Clock Input – Figure 3.7 and Figure 3.9								
t _{SU_GDDR2}	Data Setup before CLK Input	—	—	—	—	—	—	ns
		0.175	—	0.175	—	0.206	—	UI
t _{HO_GDDR2}	Data Hold after CLK Input	0.175	—	0.175	—	0.175	—	ns
t _{DVB_GDDR2}	Output Data Valid Before CLK Output	0.177	—	0.177	—	0.206	—	ns
		0.38	—	0.352	—	0.415	—	ns + 1/2 UI
t _{DQVA_GDDR2}	Output Data Valid After CLK Output	-0.12	—	-0.148	—	-0.174	—	ns
		0.38	—	0.352	—	0.415	—	ns + 1/2 UI
f _{DATA_GDDR2}	Input/Output Data Rate	-0.12	—	-0.148	—	-0.174	—	Mbps
f _{MAX_GDDR2}	Frequency for ECLK	—	1000	—	1000	—	848	MHz
½ UI	Half of Data Bit Time, or 90 degree	—	500	—	500	—	424	ns
f _{PCLK}	PCLK frequency	0.5	—	0.5	—	0.589	—	MHz
Output TX to Input RX Margin per Edge		0.23	—	0.202	—	0.239	—	ns
Generic DDRX2 Inputs/Outputs with Clock and Data Aligned at Pin (GDDR2_RX/TX.ECLK.Aligned) using PCLK Clock Input – Figure 3.8 and Figure 3.10								
t _{DVA_GDDR2}	Input Data Valid After CLK	—	-0.275	—	-0.275	—	-0.324	ns + 1/2 UI
		—	0.225	—	0.225	—	0.265	ns
		—	0.225	—	0.225	—	0.225	UI
t _{DVE_GDDR2}	Input Data Hold After CLK	0.275	—	0.275	—	0.324	—	ns + 1/2 UI
		0.775	—	0.775	—	0.914	—	ns
		0.775	—	0.775	—	0.775	—	UI
t _{DIA_GDDR2}	Output Data Invalid After CLK Output	—	0.12	—	0.148	—	0.174	ns
t _{DIB_GDDR2}	Output Data Invalid Before CLK Output	—	0.12	—	0.148	—	0.174	ns
f _{DATA_GDDR2}	Input/Output Data Rate	—	1000	—	1000	—	848	Mbps
f _{MAX_GDDR2}	Frequency for ECLK	—	500	—	500	—	424	MHz
½ UI	Half of Data Bit Time, or 90 degree	0.5	—	0.5	—	0.589	—	ns
f _{PCLK}	PCLK frequency	—	250	—	250	—	212.1	MHz
Output TX to Input RX Margin per Edge		0.105	—	0.077	—	0.091	—	ns
Generic DDRX4 Inputs/Outputs with Clock and Data Centered at Pin (GDDR4_RX/TX.ECLK.Centered) using PCLK Clock Input – Figure 3.7 and Figure 3.9								
t _{SU_GDDR4}	Input Data Set-Up Before CLK	0.168	—	0.210	—	0.244	—	ns
		0.252	—	0.252	—	0.252	—	UI
t _{HO_GDDR4}	Input Data Hold After CLK	0.174	—	0.210	—	0.244	—	ns
t _{DVB_GDDR4}	Output Data Valid Before CLK Output	0.213	—	0.269	—	0.309	—	—
		-0.12	—	-0.148	—	-0.174	—	—
t _{DQVA_GDDR4}	Input/Output Data Rate	0.213	—	0.269	—	0.309	—	—
		-0.12	—	-0.148	—	-0.174	—	—
f _{DATA_GDDR4}	Frequency for ECLK	—	1500	—	1200	—	1034	Mbps
f _{MAX_GDDR4}	PCLK frequency	—	750	—	600	—	517	MHz
½ UI	Half of Data Bit Time, or 90 degree	0.333	—	0.417	—	0.483	—	ns

Parameter	Description	-9		-8		-7		Unit
		Min	Max	Min	Max	Min	Max	
f _{PCLK}	Input Data Set-Up Before CLK	—	187.5	—	150	—	129.3	MHz
Output TX to Input RX Margin per Edge		0.08	—	0.102	—	0.116	—	ns
Generic DDRX4 Inputs/Outputs with Clock and Data Aligned at Pin (GDDR4_RX/TX.ECLK.Aligned) using PCLK Clock Input, Left and Right sides Only – Figure 3.8 and Figure 3.10								
t _{DVA_GDDR4}	Input Data Valid After CLK	—	-0.183	—	-0.229	—	-0.266	ns + 1/2 UI
		—	0.15	—	0.188	—	0.218	ns
		—	0.225	—	0.225	—	0.225	UI
t _{DVE_GDDR4}	Input Data Hold After CLK	0.183	—	0.229	—	0.266	—	ns + 1/2 UI
		0.517	—	0.646	—	0.749	—	ns
		0.775	—	0.775	—	0.775	—	UI
t _{DIA_GDDR4}	Output Data Invalid After CLK Output	—	0.12	—	0.148	—	0.17	ns
t _{DIB_GDDR4}	Output Data Invalid Before CLK Output	—	0.12	—	0.148	—	0.174	ns
f _{DATA_GDDR4}	Input/Output Data Rate	—	1500	—	1200	—	1034	Mbps
f _{MAX_GDDR4}	Frequency for ECLK	—	750	—	600	—	517	MHz
½ UI	Half of Data Bit Time, or 90 degree	0.333	—	0.417	—	0.483	—	ns
f _{PCLK}	PCLK frequency	—	187.5	—	150	—	129.3	MHz
Output TX to Input RX Margin per Edge		0.03	—	0.04	—	0.044	—	ns
Generic DDRX5 Inputs/Outputs with Clock and Data Centered at Pin (GDDR5_RX/TX.ECLK.Centered) using PCLK Clock Input – Figure 3.7 and Figure 3.9								
t _{SU_GDDR5}	Input Data Set-Up Before CLK	0.179	—	0.187	—	0.224	—	ns
		0.224	—	0.224	—	0.224	—	UI
t _{HO_GDDR5}	Input Data Hold After CLK	0.181	—	0.187	—	0.224	—	ns
t _{WINDOW_GDDR5C}	Input Data Valid Window	0.36	—	0.374	—	0.448	—	ns
t _{DVB_GDDR5}	Output Data Valid Before CLK Output	0.28	—	0.269	—	0.326	—	ns
		-0.120	—	-0.148	—	-0.174	—	ns+1/2UI
t _{DQVA_GDDR5}	Output Data Valid After CLK Output	0.28	—	0.269	—	0.326	—	ns
		-0.120	—	-0.148	—	-0.174	—	ns+1/2UI
f _{DATA_GDDR5}	Input/Output Data Rate	—	1250	—	1200	—	1000	Mbps
f _{MAX_GDDR5}	Frequency for ECLK	—	625	—	600	—	500	MHz
½ UI	Half of Data Bit Time, or 90 degree	0.4	—	0.417	—	0.5	—	ns
f _{PCLK}	PCLK frequency	—	125	—	120	—	100	MHz
Output TX to Input RX Margin per Edge		0.12	—	0.102	—	0.126	—	ns
Generic DDRX5 Inputs/Outputs with Clock and Data Aligned at Pin (GDDR5_RX/TX.ECLK.Aligned) using PCLK Clock Input – Figure 3.8 and Figure 3.10								
t _{DVA_GDDR5}	Input Data Valid After CLK	—	-0.220	—	-0.229	—	-0.275	ns + 1/2 UI
		—	0.18	—	0.188	—	0.225	ns
		—	0.225	—	0.225	—	0.225	UI
t _{DVE_GDDR5}	Input Data Hold After CLK	0.22	—	0.229	—	0.275	—	ns + 1/2 UI
		0.62	—	0.646	—	0.775	—	ns
		0.775	—	0.775	—	0.775	—	UI
t _{WINDOW_GDDR5A}	Input Data Valid Window	0.440	—	0.458	—	0.550	—	ns

Parameter	Description	-9		-8		-7		Unit
		Min	Max	Min	Max	Min	Max	
t _{DIA_GDDR5}	Output Data Invalid After CLK Output	—	0.12	—	0.148	—	0.174	ns
t _{DIB_GDDR5}	Output Data Invalid Before CLK Output	—	0.12	—	0.148	—	0.174	ns
f _{DATA_GDDR5}	Input/Output Data Rate	—	1250	—	1200	—	1000	Mbps
f _{MAX_GDDR5}	Frequency for ECLK	—	625	—	600	—	500	MHz
½ UI	Half of Data Bit Time, or 90 degree	0.4	—	0.417	—	0.5	—	ns
f _{PCLK}	PCLK frequency	—	125	—	120	—	100	MHz
Output TX to Input RX Margin per Edge		0.06	—	0.04	—	0.051	—	ns
Soft D-PHY DDRX4 Inputs/Outputs with Clock and Data Centered at Pin, using PCLK Clock Input								
t _{SU_GDDR4_MP}	Input Data Set-Up Before CLK	0.133	—	0.167	—	0.193	—	ns
		0.2	—	0.2	—	0.2	—	UI
t _{HO_GDDR4_MP}	Input Data Hold After CLK	0.133	—	0.167	—	0.193	—	ns
t _{DVB_GDDR4_MP}	Output Data Valid Before CLK Output	0.133	—	0.167	—	0.193	—	ns
		0.2	—	0.2	—	0.2	—	UI
t _{DQVA_GDDR4_MP}	Output Data Valid After CLK Output	0.133	—	0.167	—	0.193	—	ns
		0.2	—	0.2	—	0.2	—	UI
f _{DATA_GDDR4_MP}	Input Data Bit Rate for MIPI PHY	—	1500	—	1200	—	1034	Mbps
½ UI	Half of Data Bit Time, or 90 degree	0.333	—	0.417	—	0.483	—	ns
f _{PCLK}	PCLK frequency	—	187.5	—	150	—	129.3	MHz
Output TX to Input RX Margin per Edge		0.067	—	0.083	—	0.097	—	ns
Video DDRX71 Inputs/Outputs with Clock and Data Aligned at Pin (GDDR71_RX.ECLK) using PLL Clock Input – Figure 3.12 and Figure 3.13								
t _{RPBI_DVA}	Input Valid Bit "i" switch from CLK Rising Edge ("i" = 0 to 6, 0 aligns with CLK)	—	0.264	—	0.264	—	0.3	UI
		—	-0.250	—	-0.250	—	-0.249	ns+(1/2+i)*UI
t _{RPBI_DVE}	Input Hold Bit "i" switch from CLK Rising Edge ("i" = 0 to 6, 0 aligns with CLK)	0.722	—	0.722	—	0.7	—	UI
		0.235	—	0.235	—	0.249	—	ns+(1/2+i)*UI
t _{TPBI_DOV}	Data Output Valid Bit "i" switch from CLK Rising Edge ("i" = 0 to 6, 0 aligns with CLK)	—	0.159	—	0.159	—	0.187	ns+i*UI
t _{TPBI_DOI}	Data Output Invalid Bit "i" switch from CLK Rising Edge ("i" = 0 to 6, 0 aligns with CLK)	0.159	—	0.159	—	0.187	—	ns+(i+ 1)*UI
t _{TPBI_skew_UI}	TX skew in UI	—	0.15	—	0.15	—	0.15	UI
t _B	Serial Data Bit Time, = 1UI	1.058	—	1.058	—	1.247	—	ns
f _{DATA_TX71}	DDR71 Serial Data Rate	—	945	—	945	—	802	Mbps
f _{MAX_TX71}	DDR71 ECLK Frequency	—	473	—	473	—	401	MHz
f _{CLKIN}	7:1 Clock (PCLK) Frequency	—	135	—	135	—	114.5	MHz
Output TX to Input RX Margin per Edge		0.159	—	0.159	—	0.187	—	ns

Parameter	Description	-9		-8		-7		Unit
		Min	Max	Min	Max	Min	Max	
Memory Interface								
DDR3/DDR3L/LPDDR2/LPDDR3 READ (DQ Input Data are Aligned to DQS) – Figure 3.8								
t _{DVBDQ_DDR3} t _{DVBDQ_DDR3L} t _{DVBDQ_LPDDR2} t _{DVBDQ_LPDDR3}	Data Input Valid before DQS Input	—	-0.235	—	-0.235	—	-0.277	ns + 1/2 UI
t _{DVADQ_DDR3} t _{DVADQ_DDR3L} t _{DVADQ_LPDDR2} t _{DVADQ_LPDDR3}	Data Input Valid after DQS Input	0.235	—	0.235	—	0.277	—	ns + 1/2 UI
f _{DATA_DDR3} f _{DATA_DDR3L} f _{DATA_LPDDR2} f _{DATA_LPDDR3}	DDR Memory Data Rate	—	1066	—	1066	—	904	Mb/s
f _{MAX_ECLK_DDR3} f _{MAX_ECLK_DDR3L} f _{MAX_ECLK_LPDDR2} f _{MAX_ECLK_LPDDR3}	DDR Memory ECLK Frequency	—	533	—	533	—	452	MHz
f _{MAX_SCLK_DDR3} f _{MAX_SCLK_DDR3L} f _{MAX_SCLK_LPDDR2} f _{MAX_SCLK_LPDDR3}	DDR Memory SCLK Frequency	—	133.3	—	133.3	—	113	MHz
DDR3/DDR3L/LPDDR2/LPDDR3 WRITE (DQ Output Data are Centered to DQS) – Figure 3.11								
t _{DQVBS_DDR3} t _{DQVBS_DDR3L} t _{DQVBS_LPDDR2} t _{DQVBS_LPDDR3}	Data Output Valid before DQS Output	—	-0.235	—	-0.235	—	-0.277	ns + 1/2 UI
t _{DQVAS_DDR3} t _{DQVAS_DDR3L} t _{DQVAS_LPDDR2} t _{DQVAS_LPDDR3}	Data Output Valid after DQS Output	0.235	—	0.235	—	0.277	—	ns + 1/2 UI
f _{DATA_DDR3} f _{DATA_DDR3L} f _{DATA_LPDDR2} f _{DATA_LPDDR3}	DDR Memory Data Rate	—	1066	—	1066	—	904	Mb/s
f _{MAX_ECLK_DDR3} f _{MAX_ECLK_DDR3L} f _{MAX_ECLK_LPDDR2} f _{MAX_ECLK_LPDDR3}	DDR Memory ECLK Frequency	—	533	—	533	—	452	MHz
f _{MAX_SCLK_DDR3} f _{MAX_SCLK_DDR3L} f _{MAX_SCLK_LPDDR2} f _{MAX_SCLK_LPDDR3}	DDR Memory SCLK Frequency	—	133.3	—	133.3	—	113	MHz

Notes:

- Commercial timing numbers are shown. Industrial numbers are typically slower and can be extracted from the Lattice Radiant software.
- General I/O timing numbers are based on LVCMOS 1.8, 8 mA, Fast Slew Rate, 0 pf load for all IOs except the bank1. For bank1, the number are based on LVCMOS 3.3, 12 mA, Fast Slew Rate, 0 pf load.
Generic DDR timing are numbers based on LVDS I/O.
DDR3 timing numbers are based on SSTL15.
LPDDR2 and LPDDR3 timing numbers are based on HSUL12.
- Uses LVDS I/O standard for measurements.
- Maximum clock frequencies are tested under best case conditions. System performance may vary upon the user environment.
- All numbers are generated with the Lattice Radiant software.

6. This clock skew is not the internal clock network skew. Nexus family devices have very low internal clock network skew that can be approximated to 0 ps. These t_{skew} values measured externally at system level includes additional skew added by the I/O, wire bonding and package ball.

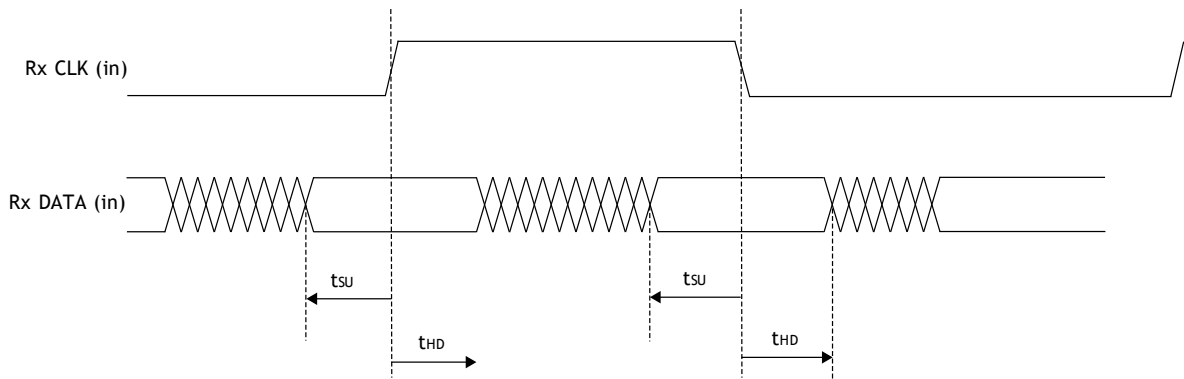

Figure 3.7. Receiver RX.CLK.Centered Waveforms

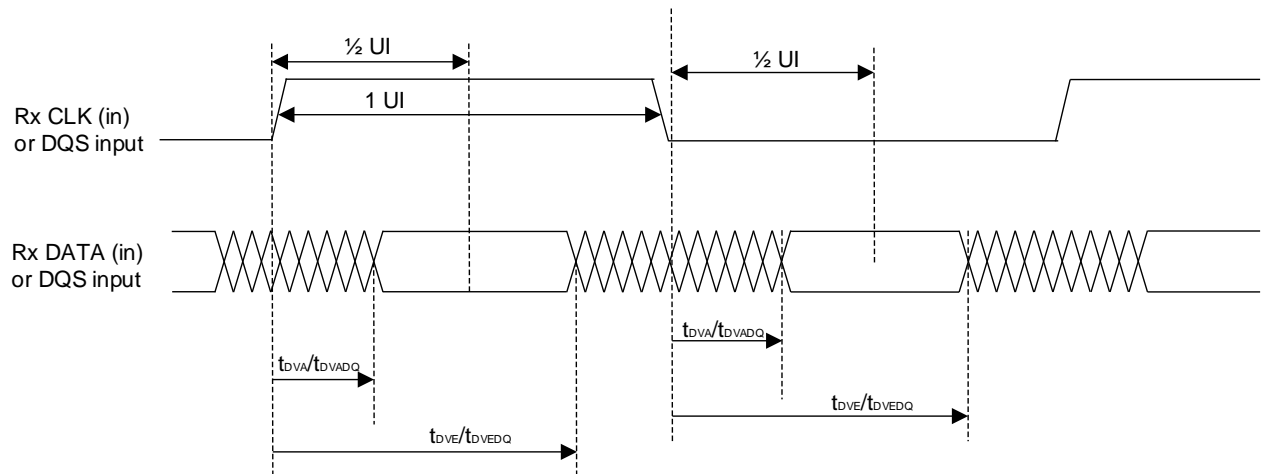

Figure 3.8. Receiver RX.CLK.Aligned and DDR Memory Input Waveforms

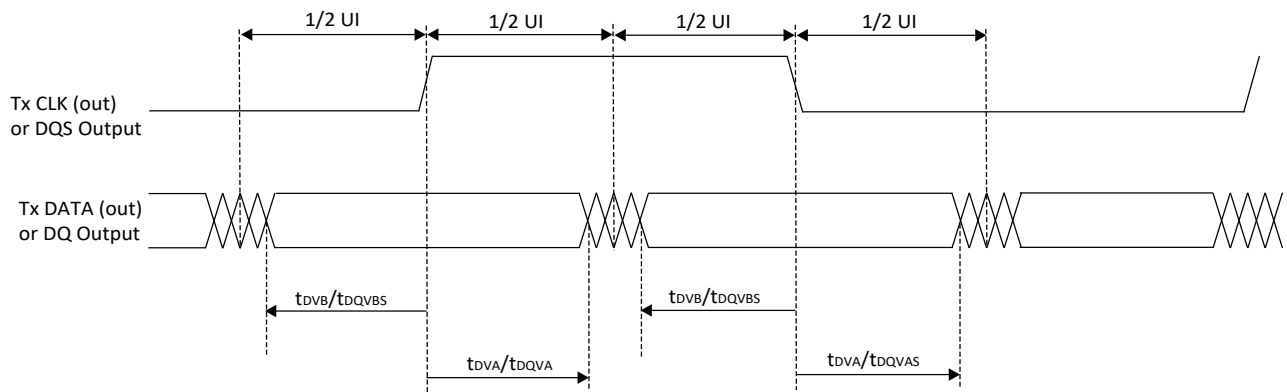

Figure 3.9. Transmit TX.CLK.Centered and DDR Memory Output Waveforms

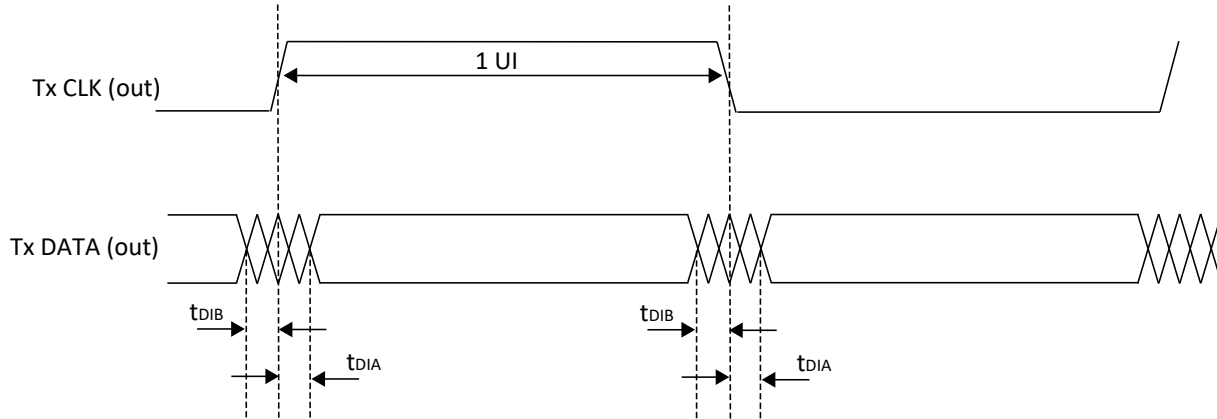
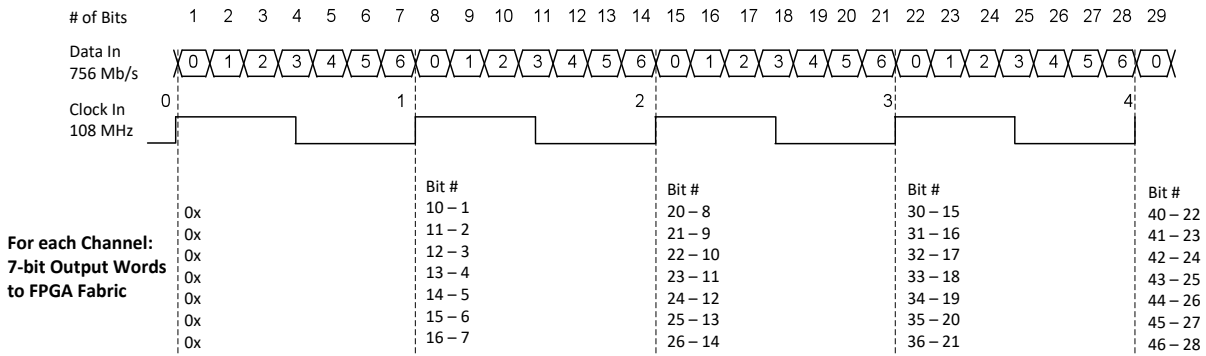

Figure 3.10. Transmit TX.CLK.Aligned Waveforms

Receiver – Shown for one LVDS Channel



Transmitter – Shown for one LVDS Channel

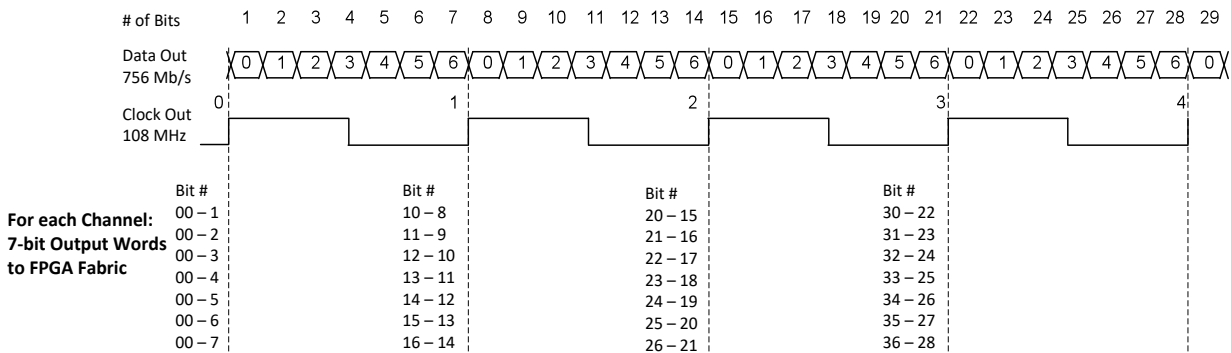

Figure 3.11. DDRX71 Video Timing Waveforms

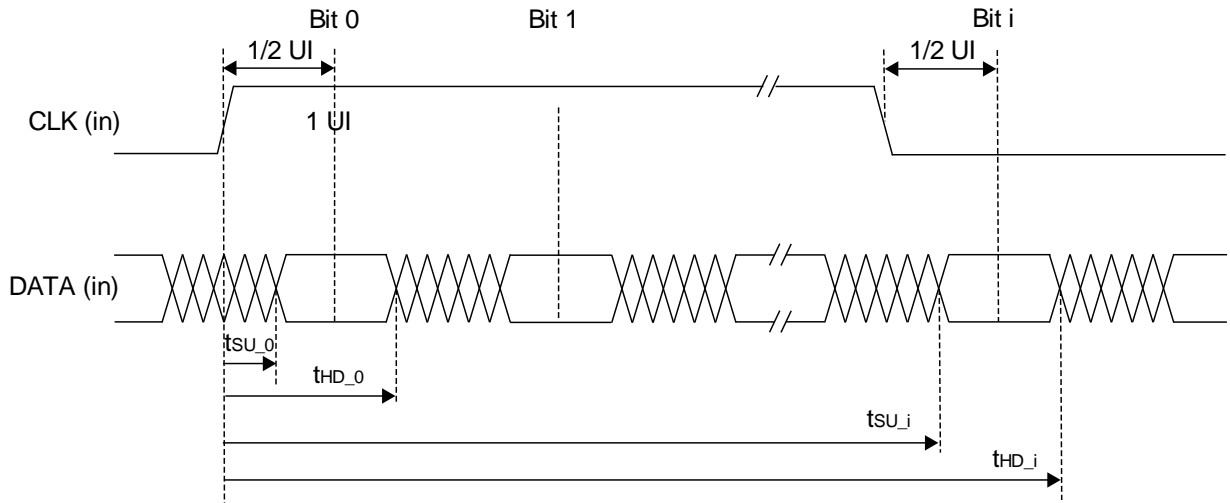

Figure 3.12. Receiver DDRX71_RX Waveforms

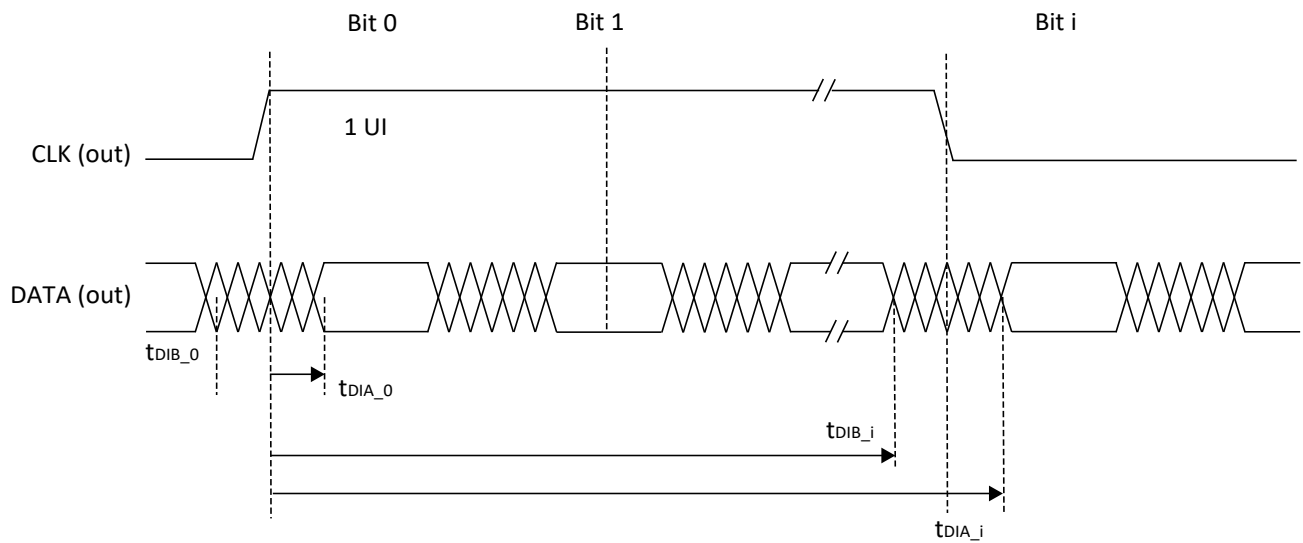

Figure 3.13. Transmitter DDRX71_TX Waveforms

3.19. sysCLOCK PLL Timing ($V_{CC} = 1.0\text{ V}$)

Over recommended operating conditions.

Table 3.35. sysCLOCK PLL Timing ($V_{CC} = 1.0\text{ V}$)

Parameter	Descriptions	Conditions	Min	Typ.	Max	Units
f_{IN}	Input Clock Frequency (CLKI, CLKFB)	—	18	—	500	MHz
f_{OUT}	Output Clock Frequency	—	6.25	—	800	MHz
f_{VCO}	PLL VCO Frequency	—	800	—	1600	MHz
f_{PFD}	Phase Detector Input Frequency	Without Fractional-N Enabled	18	—	500	MHz
		With Fractional-N Enabled	18	—	100	MHz
AC Characteristics						
t_{DT}	Output Clock Duty Cycle	—	45	—	55	%
t_{PH}^4	Output Phase Accuracy	—	-5	—	5	%
t_{OPJIT}^1	Output Clock Period Jitter	$f_{OUT} \geq 200\text{ MHz}$	—	—	250	ps p-p
		$f_{OUT} < 200\text{ MHz}$	—	—	0.05	UIPP
	Output Clock Cycle-to-Cycle Jitter	$f_{OUT} \geq 200\text{ MHz}$	—	—	250	ps p-p
		$f_{OUT} < 200\text{ MHz}$	—	—	0.05	UIPP
	Output Clock Phase Jitter	$f_{PFD} \geq 200\text{ MHz}$	—	—	250	ps p-p
		$60\text{ MHz} \leq f_{PFD} < 200\text{ MHz}$	—	—	350	ps p-p
		$30\text{ MHz} \leq f_{PFD} < 60\text{ MHz}$	—	—	450	ps p-p
		$18\text{ MHz} \leq f_{PFD} < 30\text{ MHz}$	—	—	650	ps p-p
	Output Clock Period Jitter (Fractional-N)	$f_{OUT} \geq 200\text{ MHz}$	—	—	350	ps p-p
		$f_{OUT} < 200\text{ MHz}$	—	—	0.07	UIPP
	Output Clock Cycle-to-Cycle Jitter (Fractional-N)	$f_{OUT} \geq 200\text{ MHz}$	—	—	400	ps p-p
		$f_{OUT} < 200\text{ MHz}$	—	—	0.08	UIPP
f_{BW}^3	PLL Loop Bandwidth	—	0.45	—	13	MHz
t_{LOCK}^2	PLL Lock-in Time	—	—	—	10	ms
t_{UNLOCK}	PLL Unlock Time (from RESET goes HIGH)	—	—	—	50	ns
t_{IPJIT}	Input Clock Period Jitter	$f_{PFD} \geq 20\text{ MHz}$	—	—	500	ps p-p
		$f_{PFD} < 20\text{ MHz}$	—	—	0.01	UIPP
t_{HI}	Input Clock High Time	90% to 90%	0.5	—	—	ns
t_{LO}	Input Clock Low Time	10% to 10%	0.5	—	—	ns
t_{RST}	RST/ Pulse Width	—	1	—	—	ms
f_{SSC_MOD}	Spread Spectrum Clock Modulation Frequency	—	20	—	200	kHz
$f_{SSC_MOD_AMP}$	Spread Spectrum Clock Modulation Amplitude Range	—	0.25	—	2.00	%
$f_{SSC_MOD_STEP}$	Spread Spectrum Clock Modulation Amplitude Step Size	—	—	0.25	—	%

Notes:

1. Jitter sample is taken over 10,000 samples for Period jitter, and 1,000 samples for Cycle-to-Cycle jitter of the primary PLL output with clean reference clock with no additional I/O toggling.
2. Output clock is valid after t_{LOCK} for PLL reset and dynamic delay adjustment.
3. Result from Lattice Radiant software.
4. CLKOS as compared to CLKOP output for one phase step at the maximum VCO frequency.

3.20. Internal Oscillators Characteristics

Table 3.36. Internal Oscillators ($V_{CC} = 1.0\text{ V}$)

Symbol	Parameter Description	Min	Typ	Max	Unit
f_{CLKHF}	HFOSC CLKK Clock Frequency	418.5	450	481.5	MHz
f_{CLKLF}	LFOSC CLKK Clock Frequency	25.6	32	38.4	kHz
DCH_{CLKHF}	HFOSC Duty Cycle (Clock High Period)	45	50	55	%
DCH_{CLKLF}	LFOSC Duty Cycle (Clock High Period)	45	50	55	%

3.21. Flash Download Time

Table 3.37. Flash Download Time

Symbol	Parameter	Device	Typ.	Units
$t_{REFRESH}$	POR to Device I/O Active	LFMXO5-25	46	ms

Notes:

- Assumes sysMEM EBR initialized to an all zero pattern if they are used.
- The Flash download time is measured starting from the maximum voltage of POR trip point.

3.22. Flash Program and Erase Current

Table 3.38. Program and Erase Supply Current

Symbol	Parameter	Device	Typ.	Units
I_{CC}	Core Power Supply	LFMXO5-25	26	mA

3.23. User I²C Characteristics

Table 3.39. User I²C Specifications ($V_{CC} = 1.0\text{ V}$)

Symbol	Parameter Description	STD Mode			FAST Mode			FAST Mode Plus ²			Units
		Min	Typ	Max	Min	Typ	Max	Min	Typ	Max	
f_{SCL}	SCL Clock Frequency	—	—	100	—	—	400	—	—	1000	kHz
T_{DELAY}^1	Optional delay through delay block	—	62	—	—	62	—	—	62	—	ns

Notes:

- Refer to the I²C Specification for timing requirements. User design should set constraints in Lattice Design Software to meet this industrial I²C Specification.
- Fast Mode Plus maximum speed may be achieved by using external pull up resistor on I²C bus. Internal pull up may not be sufficient to support the maximum speed.

3.24. Analog-Digital Converter (ADC) Block Characteristics

Table 3.40. ADC Specifications¹

Symbol	Description	Condition	Min	Typ	Max	Unit
V _{REFINT_ADC}	ADC Internal Reference Voltage	—	1.14 ²	1.2	1.26 ²	V
V _{REFEXT_ADC}	ADC External Reference Voltage	—	1.0	—	1.8	V
N _{RES_ADC}	ADC Resolution	—	—	12	—	bits
ENO _{ADC}	Effective Number of Bits	—	9.9	11	—	bits
V _{SR_ADC}	ADC Input Range	Bipolar Mode, Internal V _{REF}	$\frac{V_{CM_ADC} - V_{REFINT_ADC}}{4}$	V _{CM_ADC}	$\frac{V_{CM_ADC} + V_{REFINT_ADC}}{4}$	V
		Bipolar Mode, External V _{REF}	$\frac{V_{CM_ADC} - V_{REFEXT_ADC}}{4}$	V _{REFEXT_ADC}	$\frac{V_{CM_ADC} + V_{REFEXT_ADC}}{4}$	V
		Uni-polar Mode, Internal V _{REF}	0	—	V _{REFINT_ADC}	V
		Uni-polar Mode, External V _{REF}	0	—	V _{REFEXT_ADC}	V
V _{CM_ADC}	ADC Input Common Mode Voltage (for fully differential signals)	Internal V _{REF}	—	V _{REFINT_ADC} /2	—	V
		External V _{REF}	—	V _{REFEXT_ADC} /2	—	V
f _{CLK_ADC}	ADC Clock Frequency	—	—	25	40	MHz
DC _{CLK_ADC}	ADC Clock Duty Cycle	—	48	50	52	%
f _{INPUT_ADC}	ADC Input Frequency	—	—	—	500	kHz
FS _{ADC}	ADC Sampling Rate	—	—	1	—	MS/s
N _{TRACK_ADC}	ADC Input Tracking Time	—	4	—	—	cycles ³
R _{IN_ADC}	ADC Input Equivalent Resistance	1 MS/s, Sampled @ 2 clock cycles	—	116	—	kΩ
t _{CAL_ADC}	ADC Calibration Time	—	—	—	6500	cycles ³
t _{OUTPUT_ADC}	ADC Conversion Time	Includes minimum tracking time of four cycles	25	—	—	cycles ³
DNL _{ADC}	ADC Differential Nonlinearity	—	-1	—	1	LSB
INL _{ADC}	ADC Integral Nonlinearity	—	-2 ²	—	2.21	LSB
SFDR _{ADC}	ADC Spurious Free Dynamic Range	—	67.7	77	—	dBc
THD _{ADC}	ADC Total Harmonic Distortion	—	—	-76	-66.8	dB
SNR _{ADC}	ADC Signal to Noise Ratio	—	61.9	68	—	dB
SNDR _{ADC}	ADC Signal to Noise Plus Distortion Ratio	—	61.7	67	—	dB
ERR _{GAIN_ADC}	ADC Gain Error	—	-0.5	—	0.5	% FS _{ADC}
ERR _{OFFSET_ADC}	ADC Offset Error	—	-2	—	2	LSB
C _{IN_ADC}	ADC Input Equivalent Capacitance	—	—	2	—	pF

Notes:

1. ADC is available in select speed grades. See Ordering Information.
2. Not tested; guaranteed by design.
3. ADC Sample Clock cycles. See [ADC User Guide for Nexus Platform \(FPGA-TN-02129\)](#) for more details.

3.25. Comparator Block Characteristics

Table 3.41. Comparator Specifications

Symbol	Description	Min	Typ	Max	Unit
f_{IN_COMP}	Comparator Input Frequency	—	—	10	MHz
V_{IN_COMP}	Comparator Input Voltage	0	—	$V_{CCADC18}$	V
V_{OFFSET_COMP}	Comparator Input Offset	-23	—	24	mV
V_{HYST_COMP}	Comparator Input Hysteresis	10	—	31	mV
$V_{LATENCY_COMP}$	Comparator Latency	—	—	31	ns

Note: Comparator is available in select speed grades. See Ordering Information.

3.26. Digital Temperature Readout Characteristics

Digital temperature Readout (DTR) is implemented in one of the channels of ADC1.

Table 3.42. DTR Specifications^{1, 2}

Symbol	Description	Condition	Min	Typ	Max	Unit
DTR_{RANGE}	DTR Detect Temperature Range	—	-40	—	100	°C
$DTR_{ACCURACY}$	DTR Accuracy	with external voltage ¹ reference range of 1.0 V to 1.8 V	-13	±4	13	°C
$DTR_{RESOLUTION}$	DTR Resolution	with external voltage reference	-0.3	—	0.3	°C

Notes:

- External voltage reference (VREF) should be 0.1% accurate or better. DTR sensitivity to VREF is -4.1 °C per VREF per-cent (for example, if the VREF is 1 % low, then the DTR will read +4.1 °C high).
- DTR is available in select speed grades. See the [Ordering Information](#) section.

3.27. Hardened SGMII Receiver Characteristics

3.27.1. SGMII Rx Specifications

Over recommended operating conditions.

Table 3.43. SGMII Rx

Symbol	Description	Test Conditions	Min	Typ	Max	Unit
f_{DATA}	SGMII Data Rate	—	—	1250	—	MHz
f_{REFCLK}	SGMII Reference Clock Frequency (Data Rate/10)	—	—	125	—	MHz
J_{TOL_DJ}	Jitter Tolerance, Deterministic	Periodic jitter < 300 kHz	—	—	0.1 ¹	UI
J_{TOL_TJ}	Jitter Tolerance, Total	Periodic jitter < 300 kHz	—	—	0.3 ¹	UI
$\Delta f/f$	Data Rate and Reference Clock Accuracy	—	-300	—	300	ppm

Note:

- J_{TOT} can meet the following jitter mask specification: 0 to 3.5 kHz: 10 UI; 3.5 to 700 kHz: log-log slope 10 UI to 0.05 UI; above 700 kHz: 0.05 UI.

3.28. sysCONFIG Port Timing Specifications

Over recommended operating conditions.

Table 3.44. sysCONFIG Port Timing Specifications

Symbol	Parameter	Device	Min	Typ.	Max	Unit
Slave SPI/I²C/I³C POR / REFRESH Timing						
t _{MSPi_INH}	Time during POR, from V _{CC} , V _{CCAUX} , V _{CCIO0} or V _{CCIO1} (whichever is the last) pass POR trip voltage, or REFRESH command executed, to pull PROGRAMN LOW to prevent entering MSPi mode	—	—	—	1	μs
t _{ACT_PROGRAMN_H}	Minimum time driving PROGRAMN HIGH after last activation clock	—	50	—	—	ns
t _{CONFIG_CCLK}	Minimum time to start driving CCLK (SSPI) after PROGRAMN HIGH	—	50	—	—	ns
t _{CONFIG_SCL}	Minimum time to start driving SCL (I ² C/I ³ C) after PROGRAMN HIGH	—	50	—	—	ns
PROGRAMN Configuration Timing						
t _{PROGRAMN}	PROGRAMN LOW pulse accepted	—	50	—	—	ns
t _{PROGRAMN_RJ}	PROGRAMN LOW pulse rejected	—	—	—	25	ns
t _{INIT_LOW}	PROGRAMN LOW to INITN LOW	—	—	—	100	ns
t _{INIT_HIGH}	PROGRAMN LOW to INITN HIGH	—	—	40	—	μs
		—	—	—	55	μs
t _{DONE_LOW}	PROGRAMN LOW to DONE LOW	—	—	—	2	μs
t _{DONE_HIGH}	PROGRAMN HIGH to DONE HIGH	—	—	—	125	s
t _{IODISS}	PROGRAMN LOW to I/O Disabled	—	50	—	—	ns
Slave SPI						
f _{CCLK}	CCLK input clock frequency	—	—	—	135	MHz
t _{CCLKH}	CCLK input clock pulse width HIGH	—	3.5	—	—	ns
t _{CCLKL}	CCLK input clock pulse width LOW	—	3.5	—	—	ns
t _{VMC_SLAVE}	Time from rising edge of INITN to Slave CCLK driven	—	50	—	—	ns
t _{VMC_MASTER}	CCLK input clock duty cycle	—	40	—	60	%
t _{SU_SSI}	SSI to CCLK setup time	—	3.2	—	—	ns
t _{HD_SSI}	SSI to CCLK hold time	—	1.9	—	—	ns
t _{CO_SSO}	CCLK falling edge to valid SSO output	—	—	—	30	ns
t _{EN_SSO}	CCLK falling edge to SSO output enabled	—	—	—	30	ns
t _{DIS_SSO}	CCLK falling edge to SSO output disabled	—	—	—	30	ns
t _{HIGH_SCSN}	SCSN HIGH time	—	74	—	—	ns
t _{SU_SCSN}	SCSN to CCLK setup time	—	3.5	—	—	ns
t _{HD_SCSN}	SCSN to CCLK hold time	—	1.6	—	—	ns
I²C/I³C						
f _{SCL_I2C}	SCL input clock frequency for I ² C	—	—	—	1	MHz
f _{SCL_I3C}	SCL input clock frequency for I ³ C	—	—	—	12	MHz
t _{SCLH_I2C}	SCL input clock pulse width HIGH for I ² C	—	400	—	—	ns
t _{SCLL_I2C}	SCL input clock pulse width LOW for I ² C	—	400	—	—	ns
t _{SU_SDA_I2C}	SDA to SCL setup time for I ² C	—	250	—	—	ns
t _{HD_SDA_I2C}	SDA to SCL hold time for I ² C	—	50	—	—	ns
t _{SU_SDA_I3C}	SDA to SCL setup time for I ³ C	—	30	—	—	ns
t _{HD_SDA_I3C}	SDA to SCL hold time for I ³ C	—	30	—	—	ns

Symbol	Parameter	Device	Min	Typ.	Max	Unit
t_{CO_SDA}	SCL falling edge to valid SDA output	—	—	—	200	ns
t_{EN_SDA}	SCL falling edge to SDA output enabled	—	—	—	200	ns
t_{DIS_SDA}	SCL falling edge to SDA output disabled	—	—	—	200	ns
Wake-Up Timing						
t_{DONE_HIGH}	Last configuration clock cycle to DONE going HIGH	—	—	—	60	μ s
t_{FIO_EN}	User I/O enabled in Fast I/O Mode	—	—	31.104	—	M cycles
t_{IOEN}	Config clock to user I/O enabled	—	130	—	—	ns

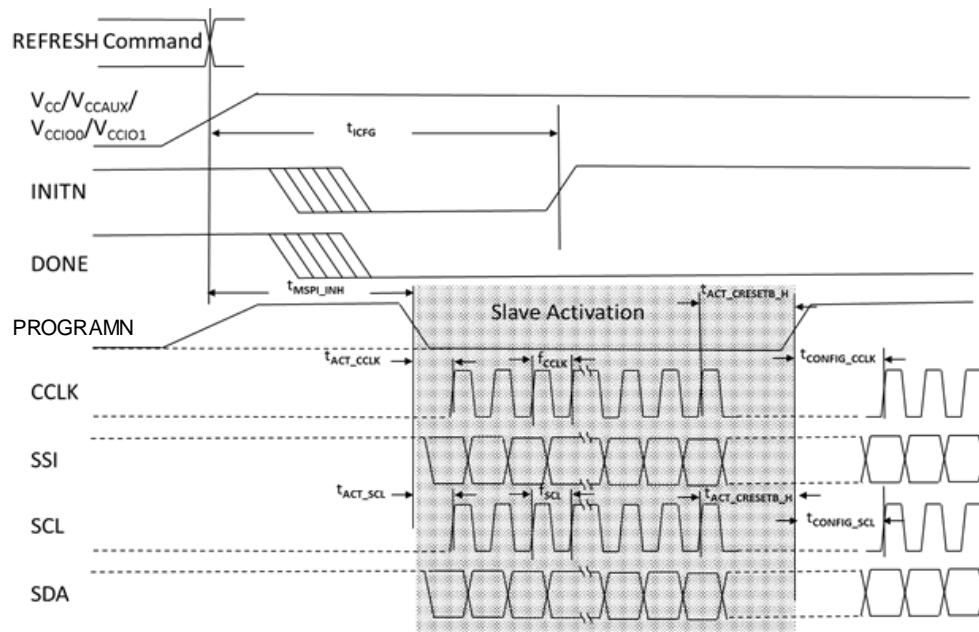

Figure 3.14. Slave SPI/I²C/I3C POR/REFRESH Timing

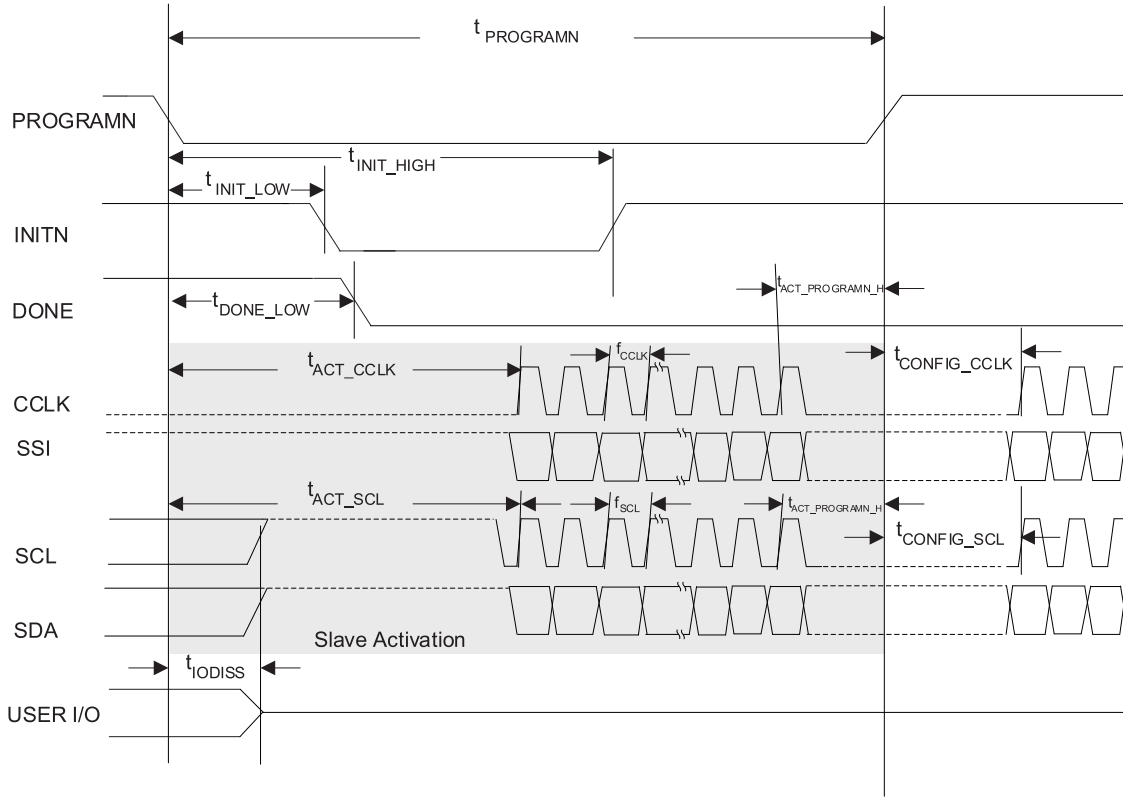

Figure 3.15. Slave SPI/I²C/I³C PROGRAMN Timing

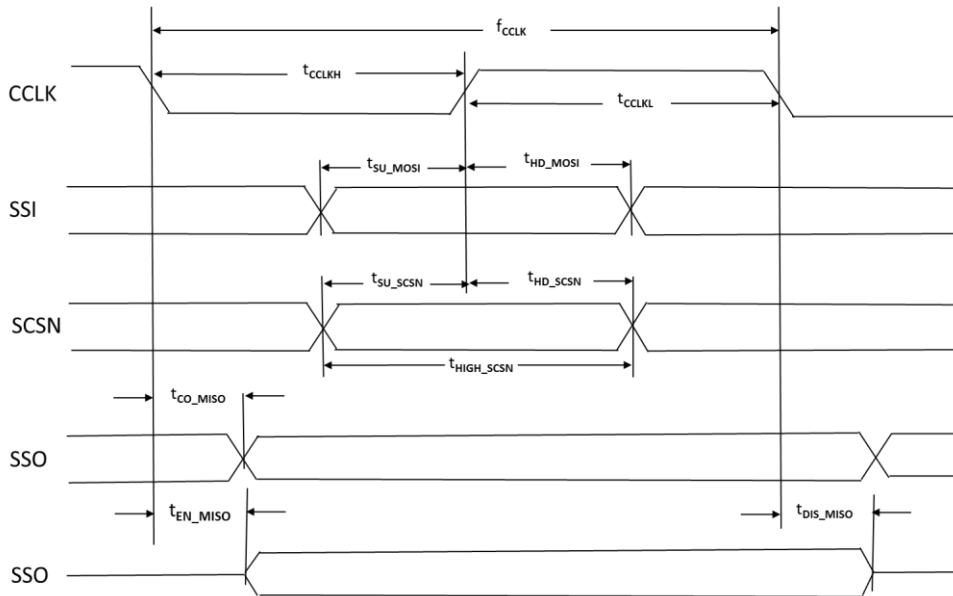

Figure 3.16. Slave SPI Configuration Timing

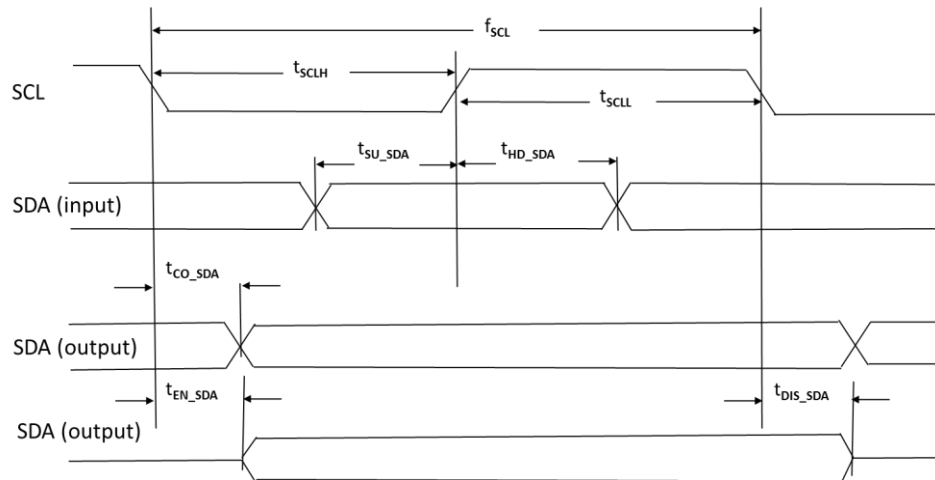

Figure 3.17. I²C /I3C Configuration Timing

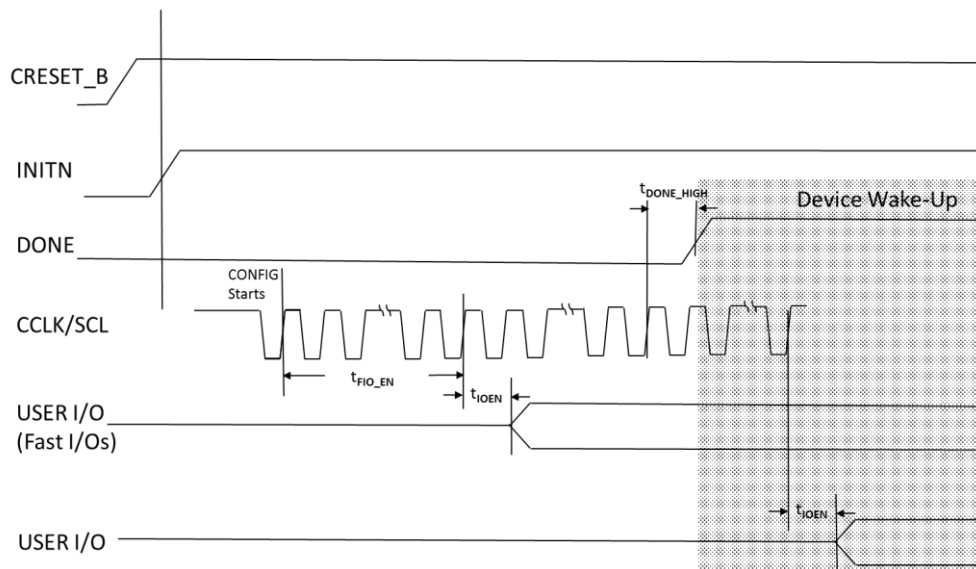

Figure 3.18. Slave SPI/I²C/I3C Wake-Up Timing

3.29. JTAG Port Timing Specifications

Over recommended operating conditions.

Table 3.45. JTAG Port Timing Specifications

Symbol	Parameter	Min	Typ.	Max	Units
f_{MAX}	TCK clock frequency	—	—	25	MHz
t_{BTCPH}	TCK clock pulse width high	20	—	—	ns
t_{BTCPL}	TCK clock pulse width low	20	—	—	ns
t_{BTS}	TCK TAP setup time	5	—	—	ns
t_{BTH}	TCK TAP hold time	5	—	—	ns
t_{BTRF}	TAP controller TDO rise/fall time ¹	1000	—	—	mV/ns
t_{BTCO}	TAP controller falling edge of clock to valid output	—	—	14	ns
$t_{BTCODIS}$	TAP controller falling edge of clock to valid disable	—	—	14	ns
t_{BTCOEN}	TAP controller falling edge of clock to valid enable	—	—	14	ns
t_{BTCRS}	BSCAN test capture register setup time	8	—	—	ns
t_{BTCRH}	BSCAN test capture register hold time	25	—	—	ns
t_{BUTCO}	BSCAN test update register, falling edge of clock to valid output	—	—	25	ns
$t_{BTUODIS}$	BSCAN test update register, falling edge of clock to valid disable	—	—	25	ns
$t_{BTUPOEN}$	BSCAN test update register, falling edge of clock to valid enable	—	—	25	ns

Note:

1. Based on default I/O setting of slow slew rate.

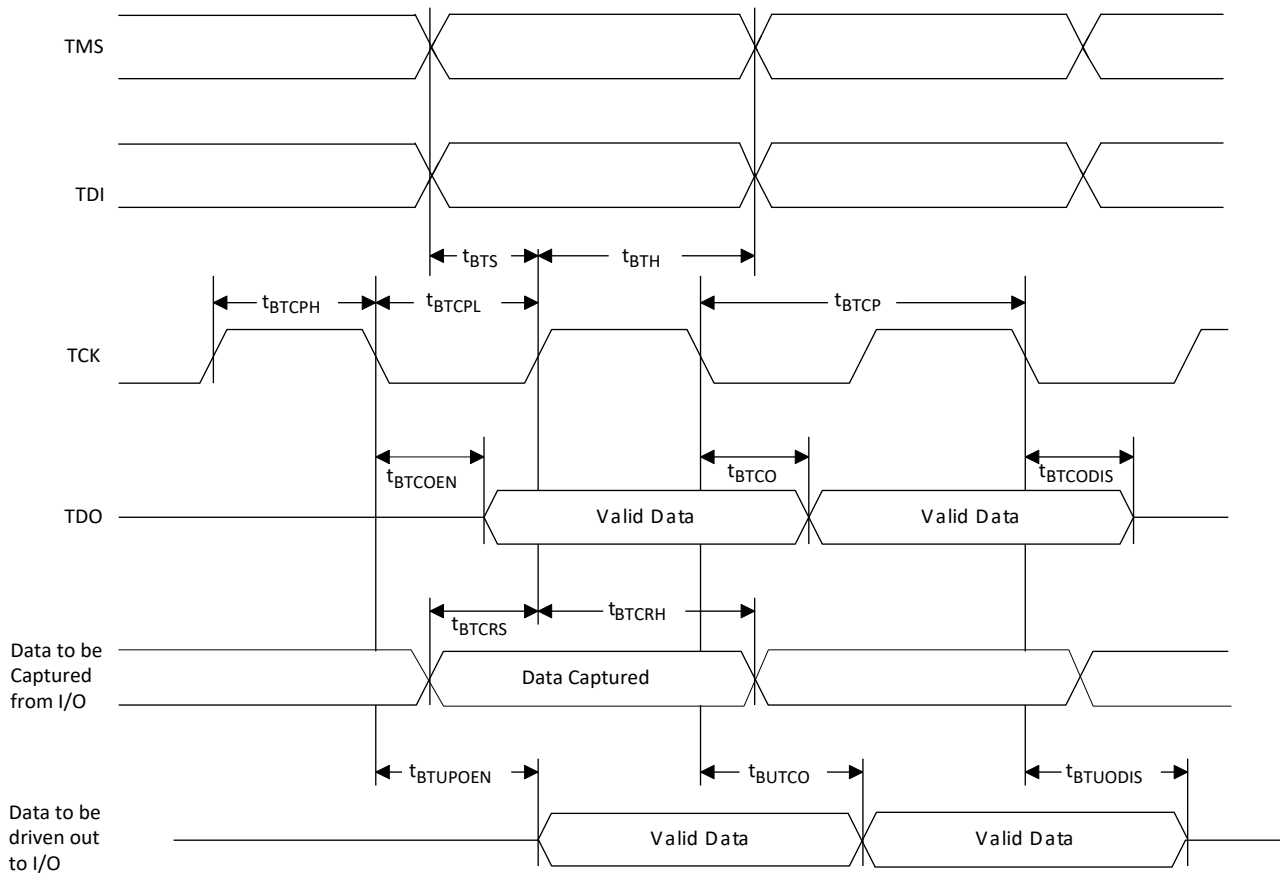
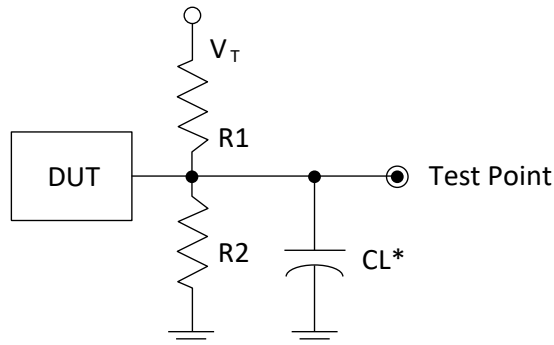

Figure 3.19. JTAG Port Timing Waveforms

3.30. Switching Test Conditions

Figure 3.20 shows the output test load that is used for AC testing. The specific values for resistance, capacitance, voltage, and other test conditions are listed in Table 3.46.



*CL Includes Test Fixture and Probe Capacitance

Figure 3.20. Output Test Load, LVTTTL and LVCMOS Standards

Table 3.46. Test Fixture Required Components, Non-Terminated Interfaces

Test Condition	R ₁	R ₂	C _L	Timing Ref.	V _T
LVTTTL and other LVCMOS settings (L ≥ H, H ≥ L)	∞	∞	0 pF	LVCMOS 3.3 = 1.5 V	—
				LVCMOS 2.5 = V _{CCIO} /2	—
				LVCMOS 1.8 = V _{CCIO} /2	—
				LVCMOS 1.5 = V _{CCIO} /2	—
				LVCMOS 1.2 = V _{CCIO} /2	—
LVCMOS 2.5 I/O (Z ≥ H)	∞	1 MΩ	0 pF	V _{CCIO} /2	—
LVCMOS 2.5 I/O (Z ≥ L)	1 MΩ	∞	0 pF	V _{CCIO} /2	V _{CCIO}
LVCMOS 2.5 I/O (H ≥ Z)	∞	100	0 pF	V _{OH} - 0.10	—
LVCMOS 2.5 I/O (L ≥ Z)	100	∞	0 pF	V _{OL} + 0.10	V _{CCIO}

Note: Output test conditions for all other interfaces are determined by the respective standards.

4. Pinout Information

4.1. Signal Descriptions

Table 4.1. Signal Descriptions

Signal Name	Bank	Type	Description
Power and GND			
V _{SS}	—	GND	Ground for internal FPGA logic and I/O
V _{CC}	—	Power	Power supply pins for core logic. V _{CC} is connected to 1.0 V (nom.) supply voltage. Power On Reset (POR) monitors this supply voltage.
V _{CCAUXA}	—	Power	Auxiliary power supply pin for internal analog circuitry. This supply is connected to 1.8 V (nom.) supply voltage. POR monitors this supply voltage.
V _{CCAUX}	—	Power	Auxiliary power supply pin for I/O Bank 0, Bank 1, Bank 2, Bank 3, Bank 4, Bank 7, Bank 8 and Bank 9. This supply is connected to 1.8 V (nom.) supply voltage, and is used for generating stable drive current for the I/O.
V _{CCAUXHX}	—	Power	Auxiliary power supply pin for I/O Bank 5 and Bank 6. This supply is connected to 1.8 V (nom.) supply voltage, and is used for generating stable current for the differential input comparators.
V _{CCIOx}	0-9	Power	Power supply pins for I/O bank x. V _{CCIO1} must be connected to (nom.) 3.3 V. For x = 0, 2, 3, 4, 7, 8 and 9 V _{CCIO} can be connected to (nom.) 1.2 V, 1.5 V, 1.8 V, 2.5 V, or 3.3 V. For x = 5 and 6, V _{CCIO} can be connected to (nom.) 1.0 V, 1.2 V, 1.35 V, 1.5 V, or 1.8 V. There are dedicated and shared configuration pins in banks 1 and 2. POR monitors these banks supply voltages.
V _{CCADC18}	—	Power	1.8 V (nom.) power supply for the ADC block.
Dedicated Pins			
Dedicated Configuration I/O Pin			
JTAG_EN	1	Input	LVCMOS input pin. This input selects the JTAG shared GPIO to be used for JTAG 0 = GPIO 1 = JTAG
Dedicated ADC I/O Pins			
ADC_REF[0, 1]	—	Input	ADC reference voltage, for each of the 2 ADC converters. If not used, tie to ground.
ADC_DP/N[0, 1]	—	Input	Dedicated ADC input pairs, for each of the 2 ADC converters. If not used, tie to ground.
Misc Pins			
NC	—	—	No connect.
RESERVED	—	—	This pin is reserved and should not be connected to anything on the board.
General Purpose I/O Pins			

Signal Name	Bank	Type	Description
P[T/B/L/R] [Number]_[A/B]	T = 0, 1 R = 2, 3, 4 B = 5, 6, 10, 11 L = 7, 8, 9	Input, Output, Bi-Dir	<p>Programmable User I/O:</p> <p>[T/B/L/R] indicates the package pin/ball is in T (Top), B (Bottom), L (Left), or R (Right) edge of the device.</p> <p>[Number] identifies the PIO [A/B] pair.</p> <p>[A/B] shows the package pin/ball is A or B signal in the pair. PIO A and PIO B are grouped as a pair.</p> <p>Each A/B pair in the bottom banks supports true differential input and output buffers. When configured as differential input, differential termination of 100 Ω can be selected.</p> <p>Each A/B pair in the top, left and right banks does not support true differential input or output buffer. It supports all single-ended inputs and outputs, and can be used for emulated differential output buffer. Some of these user-programmable I/O are used during configuration, depending on the configuration mode. You need to make appropriate connection on the board to isolate the 2 different functions before/after configuration.</p> <p>Some of these user-programmable I/O are shared with special function pins. These pins, when not used as special purpose pins, can be programmed as I/O for user logic.</p> <p>During configuration the user-programmable I/O are tri-stated with an internal weak pull-down resistor enabled. If any pin is not used (or not bonded to a package pin), it is tri-stated and default to have weak pull-down enabled after configuration.</p>
Shared Configuration Pins^{1, 2} <ol style="list-style-type: none"> These pins can be used for configuration during configuration mode. When configuration is completed, these pins can be used as GPIO, or shared function in GPIO. When these pins are used in dual function, you need to isolate the signal paths for the dual functions on the board. The pins used are defined by the configuration modes detected. Slave SPI or I²C/I³C modes are detected during slave activation. Pins that are not used in the configuration mode selected are tri-stated during configuration, and can connect directly as GPIO in user's function. 			
PRxxx /SDA/USER_SDA	1	Input, Output, Bi-Dir	<p>Configuration:</p> <p>I²C/I³C Mode: SDA signal</p> <p>User Mode:</p> <p>PRxxx: GPIO</p> <p>User_SDA: SDA signal for I²C/I³C interface</p>
PRxxx /SCL/USER_SCL	1	Input, Output, Bi-Dir	<p>Configuration:</p> <p>I²C/I³C Mode: SCL signal</p> <p>User Mode:</p> <p>PRxxx: GPIO</p> <p>User_SDA: SCL signal for I²C/I³C interface</p>
PRxxx/TDO/SSO	2	Input, Output, Bi-Dir	<p>Configuration:</p> <p>Slave SPI Mode: Slave Serial Output</p> <p>User Mode:</p> <p>PRxxx: GPIO</p> <p>TDO: When JTAG_EN = 1, used as TDO signal for JTAG</p>
PRxxx/TDI/SSI	2	Input, Output, Bi-Dir	<p>Configuration:</p> <p>Slave SPI Mode: Slave Serial Input</p> <p>User Mode:</p> <p>PRxxx: GPIO</p> <p>TDI: When JTAG_EN = 1, used as TDI signal for JTAG</p>

Signal Name	Bank	Type	Description
PRxxx/TMS/SCSN	2	Input, Output, Bi-Dir	Configuration: Slave SPI Mode: Slave Chip Select User Mode: PRxxx: GPIO TMS: When JTAG_EN = 1, used as TMS signal for JTAG
PRxxx/TCK/SCLK	2	Input, Output, Bi-Dir	Configuration: Slave SPI Mode: Slave Clock Input User Mode: PRxxx: GPIO TCK: When JTAG_EN = 1, used as TCK signal for JTAG
PTxxx/MCSNO	0	Input, Output, Bi-Dir	Configuration: Flow-through Daisy Chain Mode: Chip Select Output User Mode: PTxxx: GPIO
PTxxx/PROGRAMN	1	Input, Output, Bi-Dir	Configuration: PROGRAMN: Initiate configuration sequence when asserted LOW. User Mode: PTxxx: GPIO
PTxxx/INITN	1	Input, Output, Bi-Dir	Configuration: INITN: Open Drain I/O pin. This signal is driven to LOW when configuration sequence is started, to indicate the device is in initialization state. This signal is released after initialization is completed, and the configuration download can start. You can keep drive this signal LOW to delay configuration download to start. User Mode: PTxxx: GPIO
PTxxx/DONE	1	Input, Output, Bi-Dir	Configuration: DONE: Open Drain I/O pin. This signal is driven to LOW during configuration time. It is released to indicate the device has completed configuration. You can keep drive this signal LOW to delay the device to wake up from configuration. User Mode: PTxxx: GPIO
Shared User GPIO Pins^{1, 2, 3, 4}			
<ol style="list-style-type: none"> Shared User GPIO pins are pins that can be used as GPIO, or functional pins that connect directly to specific functional blocks, when device enters into User Mode. Declaring on assigning the pin as GPIO or specific functional pin is done by configuration bitstream, except JTAG pins. JTAG pins are controlled by JTAG_EN signal. When JTAG_EN = 1, the pins are used for JTAG interface. When JTAG = 0, the pins are used as GPIO or specific functional pin defined by configuration bitstream. Refer to package pin file. 			
Shared JTAG Pins			
PRxxx/TDO/ yyyy	1	Input, Output, Bi-Dir	User Mode: PRxxx: GPIO TDO: When JTAG_EN = 1, used as TDO signal for JTAG yyyy: Other possible selectable specific functional
PRxxx/TDI/yyyy	1	Input, Output, Bi-Dir	User Mode: PRxxx: GPIO TDI: When JTAG_EN = 1, used as TDI signal for JTAG yyyy: Other possible selectable specific functional

Signal Name	Bank	Type	Description
PRxxx/TMS/ yyyy	1	Input, Output, Bi-Dir	User Mode: PRxxx: GPIO TMS: When JTAG_EN = 1, used as TMS signal for JTAG yyyy: Other possible selectable specific functional
PRxxx/TCK/ yyyy	1	Input, Output, Bi-Dir	User Mode: PRxxx: GPIO TCK: When JTAG_EN = 1, used as TCK signal for JTAG Yyyy: Other possible selectable specific functional
Shared CLOCK Pins ¹			
1. Some PCLK pins can also be used as GPLL reference clock input pin. Refer to sysCLOCK PLL/DLL Design and User Guide for Nexus Platform (FPGA-TN-02095).			
PBxxx/PCLK[T,C][5,6]_[0-3]/yyyy	5,6	Input, Output, Bi-Dir	User Mode: PBxxx: GPIO PCLK: Primary Clock or GPLL Refclk signal [T,C] = True/Complement when using differential signaling [5,6] = Bank [0-3] Up to 4 signals in the bank yyyy: Other possible selectable specific functional
PTxxx/PCLKT[0,1]_[0-1]/yyyy	0, 1	Input, Output, Bi-Dir	User Mode: PTxxx: GPIO PCLKT: Primary Clock or GPLL Refclk signal (Only Single Ended) [0-1] Up to 2 signals in the bank yyyy: Other possible selectable specific functional
PRxxx/PCLKT[2,3,4]_[0-2]/yyyy	2, 3, 4	Input, Output, Bi-Dir	User Mode: PRxxx: GPIO PCLKT: Primary Clock or GPLL Refclk signal (Only Single Ended) [0-2] Up to 3 signals in the bank yyyy: Other possible selectable specific functional
PLxxx/PCLKT[7,8,9]_[0-2]/yyyy	7, 8, 9	Input, Output, Bi-Dir	User Mode: PLxxx: GPIO PCLKT: Primary Clock or GPLL Refclk signal (Only Single Ended) [0-2] Up to 3 signals in the bank yyyy: Other possible selectable specific functional
PBxxx/LRC_GPLL[T,C]_IN/yyyy	5	Input, Output, Bi-Dir	User Mode: PBxxx: GPIO LRC_GPLL: Lower Right GPLL Refclk signal (PLLCK) [T,C] = True/Complement when using differential signaling yyyy: Other possible selectable specific functional
PLxxx/ULC_GPLL_T_IN/yyyy	9	Input, Output, Bi-Dir	User Mode: PLxxx: GPIO ULC_GPLL: Upper Left GPLL Refclk signal (Only Single Ended) (PLLCK) yyyy: Other possible selectable specific functional
Shared VREF Pins			
PBxxx/VREF[5,6]_[1-2]/yyyy	5, 6	Input, Output, Bi-Dir	User Mode: PBxxx: GPIO VREF: Reference Voltage for DDR memory function [5,6] = Bank [1-2] Up to VREFs for each bank yyyy: Other possible selectable specific functional
Shared ADC Pins			

Signal Name	Bank	Type	Description
PBxxx/ADC_C[P,N]nn/yyyy	5, 6	Input, Output, Bi-Dir	User Mode: PBxxx: GPIO ADC_C: ADC Channel Inputs [P,N] = Positive or Negative Input nn = ADC Channel number (0 – 15) yyyy: Other possible selectable specific functional
Shared Comparator Pins			
PBxxx/COMP[1-3][P,N]/yyyy	5, 6	Input, Output, Bi-Dir	User Mode: PBxxx: GPIO COMP: Differential Comparator Input [P,N] = Positive or Negative Input [1-3] = Input to Comparators 1-3 yyyy: Other possible selectable specific functional
Shared SGMII Pins			
PBxxx/SGMII_RX[P,N][0-1]/yyyy	6	Input, Output, Bi-Dir	User Mode: PBxxx: GPIO SGMII_RX: Differential SGMII RX Inputs [P,N] = Positive or Negative Input [0-1] = Input to SGMII RX0 or RX1 yyyy: Other possible selectable specific functional

Note: Not all signals are available as external pins in all packages. Refer to the Pinout List file for various package details.

4.2. Pin Information Summary

Table 4.2. Pin Information Summary

Pins		LFMXO5-25	
		256 BBG	400 BBG
User I/O Pins			
General Purpose Inputs/Outputs per Bank	Bank 0	24	40
	Bank 1	32	36
	Bank 2	23	31
	Bank 3	16	32
	Bank 4	12	24
	Bank 5	20	24
	Bank 6	20	24
	Bank 7	12	24
	Bank 8	16	32
	Bank 9	24	32
Total Single-Ended User I/O		199	299
Differential Input/ Output Pairs	Bank 0	12	20
	Bank 1	16	18
	Bank 2	11	15
	Bank 3	8	16
	Bank 4	6	12
	Bank 5	10	12
	Bank 6	10	12
	Bank 7	6	12
	Bank 8	8	16
	Bank 9	12	16
Power Pins			
V _{CC} , V _{CC} ECLK		4	6
V _{CC} CAUXA		2	2
V _{CC} CAUX		2	3
V _{CC} CAUXHx		2	2
V _{CC} IO	Bank 0	2	3
	Bank 1	2	3
	Bank 2	2	2
	Bank 3	1	2
	Bank 4	1	2
	Bank 5	2	2
	Bank 6	2	2
	Bank 7	1	2
	Bank 8	1	2
	Bank 9	2	2
V _{CC} ADC18		1	1
Total Power Pins		27	36
GND Pins			
V _{SS}		22	30
V _{SS} ADC		1	1
Total GND Pins		23	31
Dedicated Pins			
Dedicated ADC Channels (pairs)		2	2
Dedicated ADC Reference Voltage Pins		2	2

Pins		LFMXO5-25	
		256 BBG	400 BBG
Dedicated Misc Pins			
JTAGEN		1	1
NC		0	27
RESERVED		0	0
Total Dedicated Pins		13	34
Shared Pins			
Shared Configuration Pins	Bank 0	0	0
	Bank 1	4	4
	Bank 2	6	6
	Bank 3	0	0
	Bank 4	0	0
	Bank 5	0	0
	Bank 6	0	0
	Bank 7	0	0
	Bank 8	0	0
	Bank 9	0	0
Shared JTAG Pins	Bank 0	0	0
	Bank 1	0	0
	Bank 2	4	4
	Bank 3	0	0
	Bank 4	0	0
	Bank 5	0	0
	Bank 6	0	0
	Bank 7	0	0
	Bank 8	0	0
	Bank 9	0	0
Shared PCLK Pins	Bank 0	2	2
	Bank 1	2	2
	Bank 2	3	3
	Bank 3	2	2
	Bank 4	2	2
	Bank 5	8	8
	Bank 6	8	8
	Bank 7	2	2
	Bank 8	2	2
	Bank 9	0	3
Shared GPLL Pins	Bank 0	0	0
	Bank 1	0	0
	Bank 2	0	0
	Bank 3	0	0
	Bank 4	0	0
	Bank 5	2	2
	Bank 6	0	0
	Bank 7	0	0
	Bank 8	0	0
	Bank 9	1	1

Pins		LFMXO5-25	
		256 BBG	400 BBG
Shared VREF Pins	Bank 0	0	0
	Bank 1	0	0
	Bank 2	0	0
	Bank 3	0	0
	Bank 4	0	0
	Bank 5	2	2
	Bank 6	2	2
	Bank 7	0	0
	Bank 8	0	0
	Bank 9	0	0
Shared ADC Channels (pairs)	Bank 0	0	0
	Bank 1	0	0
	Bank 2	0	0
	Bank 3	0	0
	Bank 4	0	0
	Bank 5	5	7
	Bank 6	8	9
	Bank 7	0	0
	Bank 8	0	0
	Bank 9	0	0
Shared Comparator Channels (pairs)	Bank 0	0	0
	Bank 1	0	0
	Bank 2	0	0
	Bank 3	0	0
	Bank 4	0	0
	Bank 5	3	3
	Bank 6	3	3
	Bank 7	0	0
	Bank 8	0	0
	Bank 9	0	0
Shared SGMII Channels (pairs)	Bank 0	0	0
	Bank 1	0	0
	Bank 2	0	0
	Bank 3	0	0
	Bank 4	0	0
	Bank 5	0	0
	Bank 6	2	2
	Bank 7	0	0
	Bank 8	0	0
	Bank 9	0	0

5. Ordering Information

Lattice provides a wide variety of services for its products including custom marking, factory programming, known good die, and application specific testing. Contact your local sales representatives for more details.

5.1. Part Number Description

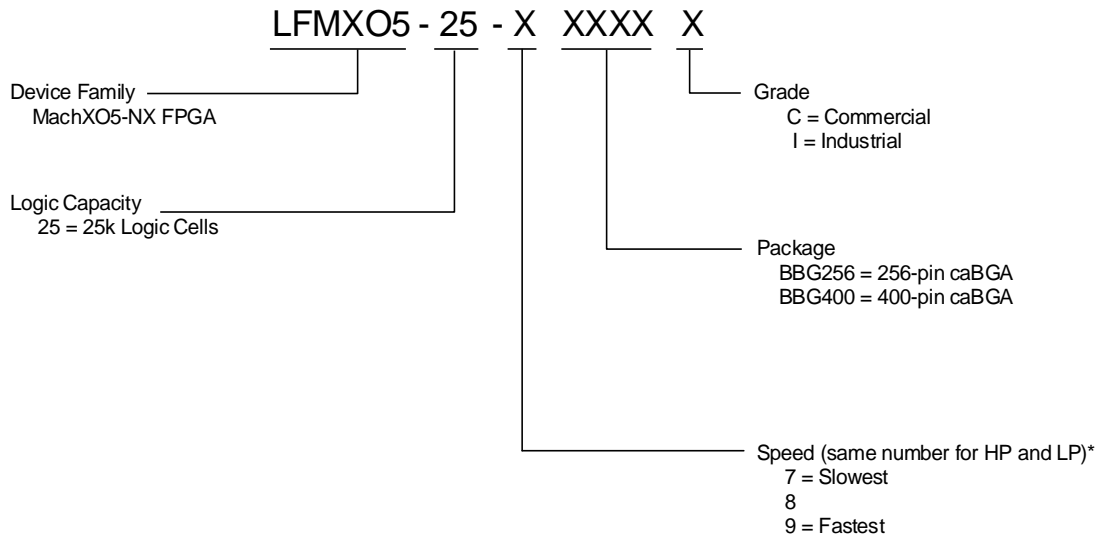

***Note:** Input Comparator, ADC, EBR ECC, and DTR are only available in –8 (–C/I) and –9 (–C/I) speed and grade.

5.2. Ordering Part Numbers

MachXO5-NX devices have either of the top-side markings as shown in the examples below.

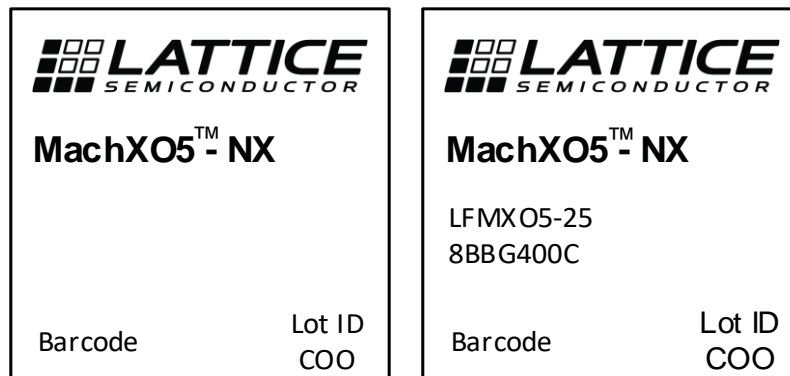

Figure 5.1. Top Marking Diagram

5.2.1. Commercial

Part Number	Speed	Package	Pins	Temp.	Logic Cells (k)
LFMXO5-25-7BBG256C	-7	Lead free caBGA	256	Commercial	25
LFMXO5-25-8BBG256C	-8	Lead free caBGA	256	Commercial	25
LFMXO5-25-9BBG256C	-9	Lead free caBGA	256	Commercial	25
LFMXO5-25-7BBG400C	-7	Lead free caBGA	400	Commercial	25
LFMXO5-25-8BBG400C	-8	Lead free caBGA	400	Commercial	25
LFMXO5-25-9BBG400C	-9	Lead free caBGA	400	Commercial	25

5.2.2. Industrial

Part Number	Speed	Package	Pins	Temp.	Logic Cells (k)
LFMXO5-25-7BBG256I	-7	Lead free caBGA	256	Industrial	25
LFMXO5-25-8BBG256I	-8	Lead free caBGA	256	Industrial	25
LFMXO5-25-9BBG256I	-9	Lead free caBGA	256	Industrial	25
LFMXO5-25-7BBG400I	-7	Lead free caBGA	400	Industrial	25
LFMXO5-25-8BBG400I	-8	Lead free caBGA	400	Industrial	25
LFMXO5-25-9BBG400I	-9	Lead free caBGA	400	Industrial	25

Supplemental Information

For Further Information

A variety of technical notes for the MachXO5-NX family are available.

- [sub-LVDS Signaling Using Lattice Devices \(FPGA-TN-02028\)](#)
- [Thermal Management \(FPGA-TN-02044\)](#)
- [sysI/O User Guide for Nexus Platform \(FPGA-TN-02067\)](#)
- [Power Management and Calculation for Certus-NX, CertusPro-NX and MachXO5-NX Devices \(FPGA-TN-02257\)](#)
- [Soft Error Detection \(SED\)/Correction \(SEC\) User Guide for Nexus Platform \(FPGA-TN-02076\)](#)
- [Using TraceID \(FPGA-TN-02084\)](#)
- [Memory User Guide for Nexus Platform \(FPGA-TN-02094\)](#)
- [sysCLOCK PLL Design and User Guide for Nexus Platform \(FPGA-TN-02095\)](#)
- [sysDSP User Guide for Nexus Platform \(FPGA-TN-02096\)](#)
- [MachXO5-NX High-Speed I/O Interface \(FPGA-TN-02286\)](#)
- [MachXO5-NX Programming and Configuration UG \(FPGA-TN-02271\)](#)
- [ADC User Guide for Nexus Platform \(FPGA-TN-02129\)](#)
- [I²C Hardened IP User Guide for Nexus Platform \(FPGA-TN-02142\)](#)
- [Multi-Boot User Guide for Nexus Platform \(FPGA-TN-02145\)](#)
- [MachXO5-NX Hardware Checklist \(FPGA-TN-02274\)](#)
- [Single Event Upset \(SEU\) Report for Nexus Platform \(FPGA-TN-02174\)](#)
- [Lattice Memory Mapped Interface and Lattice Interrupt Interface User Guide \(FPGA-UG-02039\)](#)

For further information on interface standards refer to the following websites:

- JEDEC Standards (LVTTTL, LVCMOS, SSTL) – www.jedec.org

Revision History

Revision 1.0, October 2022

Section	Change Summary
General Description	Updated processing features to include 27k logic cells in general description, Features , and in Table 1.1. MachXO5-NX Commercial/Industrial Family Selection Guide .
Architecture	Removed 100 k write cycles from the User Flash Memory (UFM) section.
DC and Switching Characteristics for Commercial and Industrial	<ul style="list-style-type: none"> • In the Power up Sequence section: <ul style="list-style-type: none"> • Table 3.4. Power-On Reset: updated all the values for both V_{PORUP} and V_{PORDN} symbols. • Newly added the Programming /Erase Specifications section and Table 3.7. Programming/Erase Specifications. • In the sysI/O Single-Ended DC Electrical Characteristics3 section: <ul style="list-style-type: none"> • Table 3.15. sysI/O DC Electrical Characteristics – Wide Range I/O (Over Recommended Operating Conditions): updated the LVTTL33/LVCMOS33 data. • Table 3.16. sysI/O DC Electrical Characteristics – High Performance I/O (Over Recommended Operating Conditions)3: updated LVCMOS18H and LVCMOS10H data. • Table 3.17. I/O Resistance Characteristics (Over Recommended Operating Conditions): updated the Min value to 65 for SE Input Termination. • Newly added Table 3.18. VIN Maximum Overshoot/Undershoot Allowance – Wide Range1,2 and Table 3.19. VIN Maximum Overshoot/Undershoot Allowance – High Performance1,2. • In the sysI/O Differential DC Electrical Characteristics section: <ul style="list-style-type: none"> • Table 3.21. LVDS25E DC Conditions: updated the Typical value to 6.03 for I_{DC} parameter. • Table 3.29. Soft D-PHY Data-Clock Timing Specifications: updated Min and Max value for $T_{SKEW[TLIS]}$ and $T_{HOLD[RX]}$ symbols. • In the Maximum sysI/O Buffer Speed section: <ul style="list-style-type: none"> • Table 3.30. Maximum I/O Buffer Speed1, 2, 3, 4, 7: updated the Max value to 250 for the HSTL15 buffer, changed to <i>HSUL12D</i> buffer in both Maximum sysI/O Input Frequency and Maximum sysI/O Output Frequency. • In the Typical Building Block Function Performance section: <ul style="list-style-type: none"> • Table 3.31. Pin-to-Pin Performance: updated Typ.@ $V_{CC} = 1.0$ V values for all the functions. • Table 3.32. Register-to-Register Performance1, 3, 4: updated Typ.@ $V_{CC} = 1.0$ V values for all the Basic, Embedded Memory, Large Memory, Distributed Memory functions. • In the LMMI section: <ul style="list-style-type: none"> • Table 3.33. LMMI FMAX Summary: updated all the f_{MAX} values. • In the External Switching Characteristics section: <ul style="list-style-type: none"> • Table 3.34. External Switching Characteristics (VCC = 1.0 V): <ul style="list-style-type: none"> • global change to all the values for all the parameters; • changed to $t_{H(LTR)}$ parameter; • newly added $t_{H(Bottom)}$, $t_{H_DEL(LTR)}$, $t_{H_DEL(Bottom)}$ parameters; • changed to $t_{SUPLL(LTF \text{ except Bank1})}$ parameter; • newly added $t_{SUPLL(Bank1)}$, $t_{SUPLL(Bottom)}$, $t_{HPLL(LTR)}$ parameters; • changed to $t_{HPLL(Bottom)}$ parameter; • newly added Generic DDRX1 Inputs/Outputs with Clock and Data Centered at Pin (GDDR1_RX/TX.SCLK.Centered) using PCLK Clock Input – Figure 3.7 and Figure 3.9 Bottom and Generic DDRX1 Inputs/Outputs with Clock and Data Aligned at Pin (GDDR1_RX/TX.SCLK.Aligned) using PCLK Clock Input – Figure 3.8 and Figure 3.10 Bottom parameters and their related values; • updated Note 2; • newly added Note 6 for t_{SKEW_PRI} and t_{SKEW_EDGE} parameters. • In the sysCLOCK PLL Timing (VCC = 1.0 V) section: <ul style="list-style-type: none"> • Table 3.35. sysCLOCK PLL Timing (VCC = 1.0 V): <ul style="list-style-type: none"> • removed footnote from f_{PFD} parameter; • indicated t_{PH} to Note 4;

Section	Change Summary
	<ul style="list-style-type: none"> removed and added conditions in t_{OPJIT} parameter to accurately reflect PLL jitter performance; updated all the values for all the parameters. In the Internal Oscillators Characteristics section: <ul style="list-style-type: none"> Table 3.36. Internal Oscillators (VCC = 1.0 V): updated all the values for all the symbols. In the Flash Download Time section: <ul style="list-style-type: none"> Table 3.37. Flash Download Time: updated typ. value for the $t_{REFRESH}$ symbol. Newly added the Flash Program and Erase Current section and Table 3.38. Program and Erase Supply Current. In the User I2C Characteristics section: <ul style="list-style-type: none"> Table 3.39. User I2C Specifications (VCC = 1.0 V): updated all the values for all the symbols. In the sysCONFIG Port Timing Specifications section: <ul style="list-style-type: none"> Table 3.44. sysCONFIG Port Timing Specifications: updated all the values for all the symbols. In the JTAG Port Timing Specifications section: <ul style="list-style-type: none"> Table 3.45. JTAG Port Timing Specifications: updated all the values for all the symbols.
Pinout Information	<p>Table 4.2. Pin Information Summary:</p> <ul style="list-style-type: none"> updated all the values for V_{CCIO} LFMXO5-25 400 BBG; updated the number of Bank 1 user I/O pins for LFMXO5-25 256 BBG.

Revision 0.82, September 2022

Section	Change Summary
Pinout Information	<ul style="list-style-type: none"> In Table 4.1. Signal Descriptions: <ul style="list-style-type: none"> changed the Bank to 2 for PRxxx/TDO/SSO, PRxxx/TDI/SSI, PRxxx/TMS/SCSN, and PRxxx/TCK/SCLK signals; changed the Bank to 1 for PTxxx/PROGRAMN, PTxxx/INITN and PTxxx/DONE signals.

Revision 0.81, August 2022

Section	Change Summary
Architecture	Changed section header to SGMII TX/RX and updated contents.
DC and Switching Characteristics for Commercial and Industrial	<ul style="list-style-type: none"> Updated Table 3.30. Maximum I/O Buffer Speed1, 2, 3, 4, 7. Corrected footnote reference of Differential to 8. Added DSP functions and adjusted footnotes in Table 3.32. Register-to-Register Performance1, 3, 4. Corrected t_{PH} parameter footnote in Table 3.35. sysCLOCK PLL Timing (VCC = 1.0 V).
All	<ul style="list-style-type: none"> Added links to referenced documents. Removed product name from headings and captions of figures and tables. Minor changes in style and formatting.

Revision 0.80, May 2022

Section	Change Summary
All	Globally changed Control Jedi-D6 to MachXO5-NX.
General Description	<ul style="list-style-type: none"> Newly changed to Dual ADC – 1 MSPS, 12-bit SAR with Simultaneous Sampling. Newly added note. Updated UFM value in Table 1.1. MachXO5-NX Commercial/Industrial Family Selection Guide.
Architecture	<ul style="list-style-type: none"> In the sysMEM Memory section: <ul style="list-style-type: none"> Changed to EBR also provides a build in ECC engine in select speed grades. Updated Figure 2.25. DQS Control and Delay Block (DQSBUF).

Section	Change Summary
	<ul style="list-style-type: none"> • Globally updated Table 2.9. DQSBUF Port List Description. • In the Analog Interface section: <ul style="list-style-type: none"> • Changed to In select speed grades, the MachXO5-NX family provides an analog interface.... • In the Device Configuration section: <ul style="list-style-type: none"> • Changed the Master SPI booting sequence to <i>self download</i> mode. • Changed to In self download mode, the FPGA boots from an external SPI boots from on-chip flash. • In the User Flash Memory (UFM) section: <ul style="list-style-type: none"> • Updated the non-volatile storage data to 15,360 kb. • Updated all the values in Table 2.14. MachXO5-NX UFM Size. • In the Pin Migration section: <ul style="list-style-type: none"> • Changed the section title from Density Shifting to <i>Pin Migration</i>.
<p>DC and Switching Characteristics for Commercial and Industrial</p>	<ul style="list-style-type: none"> • Removed Bank 10 and Bank 11 from Table 3.1. Absolute Maximum Ratings and Table 3.2. Recommended Operating Conditions. • Updated Note 1 contents of Table 3.5. On-Chip Termination Options for Input Modes. • General update to Table 3.6. Hot Socketing Specifications for GPIO. • General value update for Min., Typ. and Max. in Table 3.7. DC Electrical Characteristics – Wide Range (Over Recommended Operating Conditions) and Table 3.8. DC Electrical Characteristics – High Speed (Over Recommended Operating Conditions). • Updated Note format in Table 3.9. Capacitors – Wide Range (Over Recommended Operating Conditions) and Table 3.10. Capacitors – High Performance (Over Recommended Operating Conditions). <p>General update to Table 3.13. sysI/O Recommended Operating Conditions, Table 3.14. sysI/O DC Electrical Characteristics – Wide Range I/O (Over Recommended Operating Conditions), and Table 3.15. sysI/O DC Electrical Characteristics – High Performance I/O (Over Recommended Operating Conditions).</p> <ul style="list-style-type: none"> • In the sysI/O Differential DC Electrical Characteristics section: <ul style="list-style-type: none"> • General update to the LVDS, SubLVDS/SubLVDSSEH (Output Only) sections. • General update to: <ul style="list-style-type: none"> • Table 3.17. LVDS DC Electrical Characteristics (Over Recommended Operating Conditions) • Table 3.18. LVDS25E DC Conditions • Table 3.19. SubLVDS Input DC Electrical Characteristics (Over Recommended Operating Conditions) • Table 3.20. SubLVDS Output DC Electrical Characteristics (Over Recommended Operating Conditions) • Table 3.21. SLVS Input DC Characteristics (Over Recommended Operating Conditions) • Table 3.22. SLVS Output DC Characteristics (Over Recommended Operating Conditions) • Table 3.23. Soft D-PHY Input Timing and Levels • Table 3.24. Soft D-PHY Output Timing and Levels • Table 3.25. Soft D-PHY Clock Signal Specification • Table 3.26. Soft D-PHY Data-Clock Timing Specifications • Table 3.27. MachXO5-NX Maximum I/O Buffer Speed • Table 3.28. Pin-to-Pin Performance • Table 3.37. ADC Specifications • Table 3.38. Comparator Specifications • Table 3.39. DTR Specifications • Table 3.40. SGMII Rx • Table 3.41. MachXO5-NX sysCONFIG Port Timing Specifications • Removed the original Figure 3.14. Master SPI PRO/REFRESH Timing, Figure 3.16. Master SPI PROGRAMN Timing, Figure 3.20. Master SPI Wake-Up Timing,

Section	Change Summary
Pinout Information	Updated the Bank and description for V_{CCAUX} and V_{CCIOx} in In the Signal Descriptions section
Ordering Information	<ul style="list-style-type: none"> Newly added note to the MachXO5-NX Part Number Description section. Updated the top marking diagram in the Ordering Part Number section.
Supplemental Information	Updated document list.

Revision 0.72, December 2021

Section	Change Summary
General Description	<ul style="list-style-type: none"> Removed 52k logic cells support and related contents. In the Features section: <ul style="list-style-type: none"> changed the programmable sysI/O (High Performance and Wide Range I/O) range to "200 to 300"; changed the small footprint package option to "14 × 14 mm to 17 × 17 mm"; changed to "up to 1.4 Mb sysMEM Embedded Block RAM (EBR)" in Flexible memory resources; changed to "80 kbit distributed RAM" in Flexible memory resources.
Architecture	Removed the original Figure 2.2 Simplified Block Diagram, Control Jedi-D6-55 Device (Top Level) from the Overview section.
Pinout Information	Removed all LFMXO5-55 information from the Pin Information Summary section.
Ordering Information	<ul style="list-style-type: none"> Removed 55k logic cells capacity from the Part Number Description section. Removed 484 package from the Part Number Description section.

Revision 0.71, October 2021

Section	Change Summary
General Description	Changed <i>Configuration</i> to <i>Non-volatile Configuration</i> in the Features section.
Architecture	<ul style="list-style-type: none"> Added description regarding DSP blocks and sysMEM EBR blocks for Jedi-D6 25 device to the Overview section. Updated Figure 2.1. Simplified Block Diagram, MachXO5-25 Device (Top Level) to show non-volatile configuration and security, and on-chip user flash. Updated description regarding image configuration in the User Flash Memory (UFM) section.
Pinout Information	<ul style="list-style-type: none"> Added "if not used, tie to ground" to the description for Dedicated ADC I/O Pins, both ADC_REF and ADC_DP/N, in the Signal Descriptions section.
DC and Switching Characteristics for Commercial and Industrial	Removed the hyperlink of the D6-Control Product Family Qualification Summary in the ESD Performance section.

Revision 0.70, October 2021

Section	Change Summary
All	Initial Advance release



www.latticesemi.com

Looking for pricing, stock, or lifecycle information?

Click below to explore more details on WIN SOURCE:

-  [View LFMX05-25-7BBG256I on WIN SOURCE](#)
-  [Lattice Semiconductor Corporation Information](#)

Optimize Your Supply Chain with WIN SOURCE Solutions

-  Global Sourcing Solution
-  Obsolete Management
-  Cost Control Management
-  Shortage Management
-  Alternative Solution
-  Excess Inventory Management