



# T4 Data Sheet

---

DST4-v3.5  
February 2023  
[www.efinixinc.com](http://www.efinixinc.com)



# Contents

<b>Introduction.....</b>	<b>3</b>
<b>Features.....</b>	<b>3</b>
Available Package Options.....	4
<b>Device Core Functional Description.....</b>	<b>5</b>
XLR Cell.....	5
Logic Cell.....	5
Embedded Memory.....	6
Multipliers.....	7
Global Clock Network.....	7
Clock and Control Distribution Network.....	7
<b>Device Interface Functional Description.....</b>	<b>8</b>
Interface Block Connectivity.....	8
General-Purpose I/O Logic and Buffer.....	9
Simple I/O Buffer.....	10
I/O Banks.....	11
PLL.....	12
Oscillator.....	13
<b>Power Up Sequence.....</b>	<b>14</b>
Power Supply Current Transient.....	15
<b>Configuration.....</b>	<b>16</b>
Supported Configuration Modes.....	17
Mask-Programmable Memory Option.....	17
<b>DC and Switching Characteristics.....</b>	<b>18</b>
<b>ESD Performance.....</b>	<b>20</b>
<b>Configuration Timing.....</b>	<b>21</b>
Maximum $t_{USER}$ for SPI Active and Passive Modes.....	23
<b>PLL Timing and AC Characteristics.....</b>	<b>23</b>
<b>Internal Oscillator.....</b>	<b>24</b>
<b>Pinout Description.....</b>	<b>24</b>
<b>Efinity Software Support.....</b>	<b>27</b>
<b>T4 Interface Floorplan.....</b>	<b>27</b>
<b>Ordering Codes.....</b>	<b>27</b>
<b>Revision History.....</b>	<b>28</b>

# Introduction

The T4 FPGA features the high-density, low-power Efinix® Quantum™ architecture wrapped with an I/O interface in a small footprint package for easy integration. T4 FPGAs support mobile, consumer, and IoT edge markets that need low power, low cost, and a small form factor. With ultra-low power T4 FPGAs, designers can build products that are always on, providing enhanced capabilities for applications such as embedded vision, voice and gesture recognition, intelligent sensor hubs, and power management.

## Features

- High-density, low-power Quantum™ architecture
- Built on SMIC 40 nm process
- Less than 150  $\mu$ A typical core leakage current at 1.1 V
- Ultra-small footprint package options
- FPGA interface blocks
  - GPIO
  - PLL
  - Oscillator
- Programmable high-performance I/O
  - Supports 1.8, 2.5, and 3.3 V single-ended I/O standards and interfaces
- Flexible on-chip clocking
  - 12 low-skew global clock signals can be driven from off-chip external clock signals or PLL synthesized clock signals
  - PLL support
- Flexible device configuration
  - Standard SPI interface (active, passive, and daisy chain)
  - JTAG interface
  - Optional Mask Programmable Memory (MPM) capability
- Fully supported by the Efinity® software, an RTL-to-bitstream compiler

*Table 1: T4 FPGA Resources*

LEs <sup>(1)</sup>	Global Clock Networks	Global Control Networks	Embedded Memory (kbits)	Embedded Memory Blocks (5 Kbits)	Embedded Multipliers
3,888	Up to 16	Up to 8	76.8	15	4

<sup>(1)</sup> Logic capacity in equivalent LE counts.

**Table 2: T4 FPGA Package-Dependent Resources**

Resource	BGA49	BGA81
Available GPIO	33	55
Global clocks from GPIO pins	4	8
Global controls from GPIO pins	5	8
PLL (simple)	1	1
Oscillator	1	1
MPM	1 (optional)	1 (optional)



**Learn more:** Refer to the [Trion Packaging User Guide](#) for the package outlines and markings.

## Available Package Options

**Table 3: Available Packages**

Package	Dimensions (mm x mm)	Pitch (mm)
49-ball FBGA <sup>(2)</sup>	3 x 3	0.4
81-ball FBGA	5 x 5	0.5

<sup>(2)</sup> This package does not have dedicated JTAG pins (TDI, TDO, TCK, TMS).

# Device Core Functional Description

T4 FPGAs feature an eXchangeable Logic and Routing (XLR) cell that Efinix has optimized for a variety of applications. Trion® FPGAs contain three building blocks constructed from XLR cells: logic elements, embedded memory blocks, and multipliers. Each FPGA in the Trion® family has a custom number of building blocks to fit specific application needs. As shown in the following figure, the FPGA includes I/O ports on all four sides, as well as columns of XLR cells, memory, and multipliers. A control block within the FPGA handles configuration.

Figure 1: T4 FPGA Block Diagram

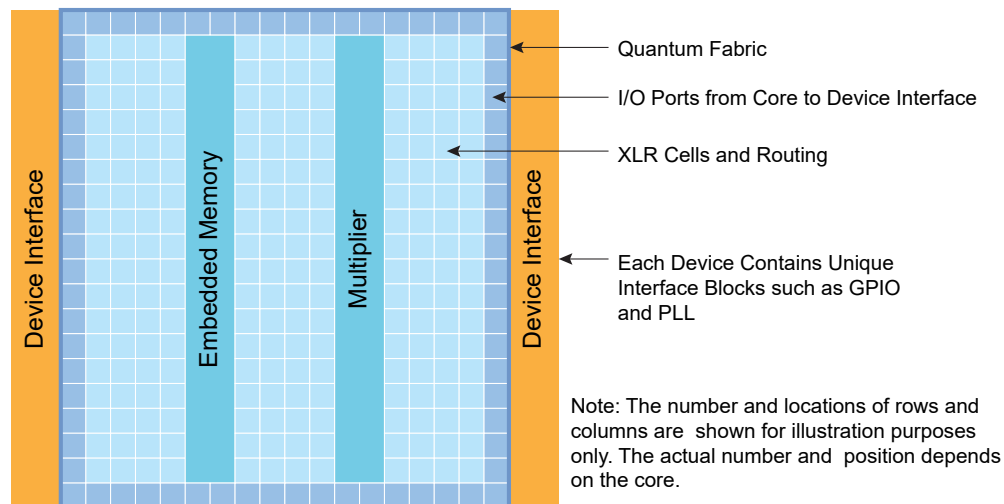

## XLR Cell

The eXchangeable Logic and Routing (XLR) cell is the basic building block of the Quantum™ architecture. The Efinix XLR cell combines logic and routing and supports both functions interchangeably. This unique innovation greatly enhances the transistor flexibility and utilization rate, thereby reducing transistor counts and silicon area significantly.

## Logic Cell

The logic cell comprises a 4-input LUT or a full adder plus a register (flipflop). You can program each LUT as any combinational logic function with four inputs. You can configure multiple logic cells to implement arithmetic functions such as adders, subtractors, and counters.

Figure 2: Logic Cell Block Diagram

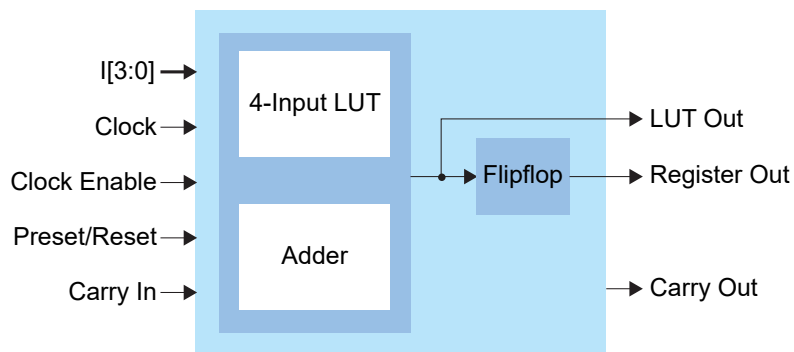

## Embedded Memory

The core has 5-kbit high-speed, synchronous, embedded SRAM memory blocks. Memory blocks can operate as single-port RAM, simple dual-port RAM, true dual-port RAM, FIFOs, or ROM. You can initialize the memory content during configuration. The Efinity<sup>®</sup> software includes a memory cascading feature to connect multiple blocks automatically to form a larger array. This feature enables you to instantiate deeper or wider memory modules.



**Note:** The block RAM content is random and undefined if it is not initialized.

The memory read and write ports have the following modes for addressing the memory (depth x width):

256 x 16	1024 x 4	4096 x 1	512 x 10
512 x 8	2048 x 2	256 x 20	1024 x 5

The read and write ports support independently configured data widths.

Figure 3: Embedded Memory Block Diagram (True Dual-Port Mode)

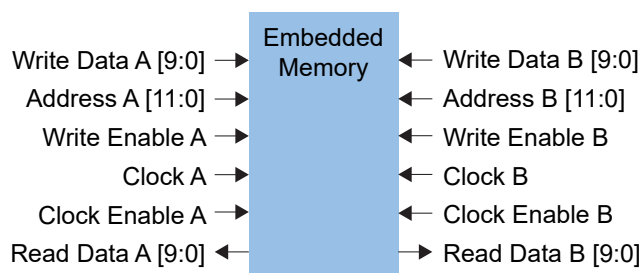

## Multipliers

The FPGA has high-performance multipliers that support 18 x 18 fixed-point multiplication. Each multiplier takes two signed 18-bit input operands and generates a signed 36-bit output product. The multiplier has optional registers on the input and output ports.

Figure 4: Multiplier Block Diagram

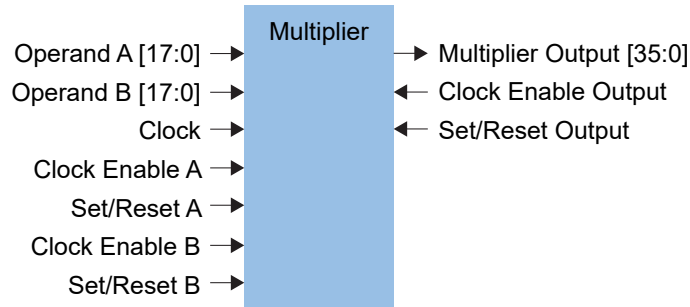

## Global Clock Network

The Quantum™ core fabric supports up to 16 global clock (GCLK) signals feeding 16 pre-built global clock networks. Global clock pins (GPIO), PLL outputs, oscillator output, and core-generated clocks can drive the global clock network.

The global clock networks are balanced clock trees that feed all FPGA modules. Each network has dedicated clock-enable logic to save power by disabling the clock tree at the root. The logic dynamically enables/disables the network and guarantees no glitches at the output.

Figure 5: Global Clock Network

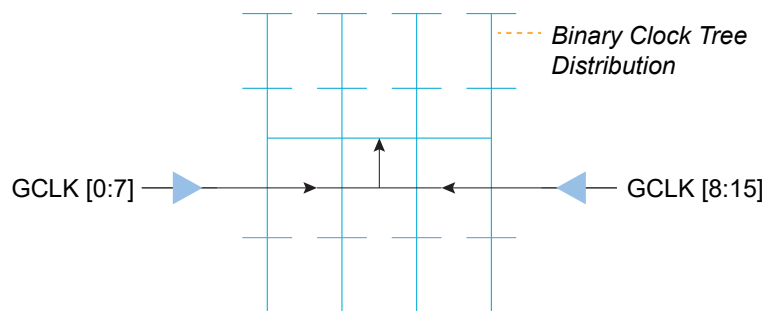

### Clock and Control Distribution Network

The global clock network is distributed through the device to provide clocking for the core's LEs, memory, multipliers, and I/O blocks. Designers can access the T4 global clock network using the global clock GPIO pins, PLL outputs, oscillator output, and core-generated clocks. Similarly, the T4 has GPIO pins (the number varies by package) that the designer can configure as control inputs to access the high-fanout network connected to the LE's set, reset, and clock enable signals.



**Learn more:** Refer to the [T4 pinout](#) for information on the location and names of these pins.

# Device Interface Functional Description

The device interface wraps the core and routes signals between the core and the device I/O pads through a signal interface. Because they use the flexible Quantum™ architecture, devices in the Trion® family support a variety of interfaces to meet the needs of different applications.



**Learn more:** The following sections describe the available device interface features in T4 FPGAs. Refer to the [Trion® Interfaces User Guide](#) for details on the Efinity® Interface Designer settings.

## Interface Block Connectivity

The FPGA core fabric connects to the interface blocks through a signal interface. The interface blocks then connect to the package pins. The core connects to the interface blocks using three types of signals:

- *Input*—Input data or clock to the FPGA core
- *Output*—Output from the FPGA core
- *Clock output*—Clock signal from the core clock tree

*Figure 6: Interface Block and Core Connectivity*

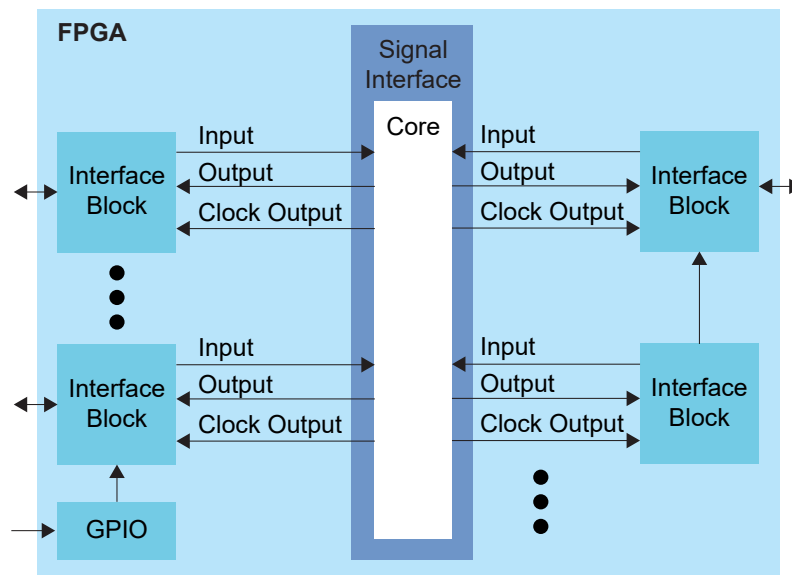

GPIO blocks are a special case because they can operate in several modes. For example, in alternate mode the GPIO signal can bypass the signal interface and directly feed another interface block. So a GPIO configured as an alternate input can be used as a PLL reference clock without going through the signal interface to the core.

When designing for Trion® FPGAs, you create an RTL design for the core and also configure the interface blocks. From the perspective of the core, outputs from the core are inputs to the interface block and inputs to the core are outputs from the interface block.

The Efinity netlist always shows signals from the perspective of the core, so some signals do not appear in the netlist:

- GPIO used as reference clocks are not present in the RTL design, they are only visible in the interface block configuration of the Efinity® Interface Designer.

- The FPGA clock tree is connected to the interface blocks directly. Therefore, clock outputs from the core to the interface are not present in the RTL design, they are only part of the interface configuration (this includes GPIO configured as output clocks).

The following sections describe the different types of interface blocks in the T4. Signals and block diagrams are shown from the perspective of the interface, not the core.

## General-Purpose I/O Logic and Buffer

The GPIO support the 3.3 V LVTTTL and 1.8 V, 2.5 V, and 3.3 V LVCMOS I/O standards. The GPIOs are grouped into banks. Each bank has its own VCCIO that sets the bank voltage for the I/O standard.

Each GPIO consists of I/O logic and an I/O buffer. I/O logic connects the core logic to the I/O buffers. I/O buffers are located at the periphery of the device.

The I/O logic comprises three register types:

- *Input*—Capture interface signals from the I/O before being transferred to the core logic
- *Output*—Register signals from the core logic before being transferred to the I/O buffers
- *Output enable*—Enable and disable the I/O buffers when I/O used as output

**Table 4: GPIO Modes**

GPIO Mode	Description
Input	Only the input path is enabled; optionally registered. If registered, the input path uses the input clock to control the registers (positively or negatively triggered). Select the alternate input path to drive the alternate function of the GPIO. The alternate path cannot be registered.
Output	Only the output path is enabled; optionally registered. If registered, the output path uses the output clock to control the registers (positively or negatively triggered). The output register can be inverted.
Bidirectional	The input, output, and OE paths are enabled; optionally registered. If registered, the input clock controls the input register, the output clock controls the output and OE registers. All registers can be positively or negatively triggered. Additionally, the input and output paths can be registered independently. The output register can be inverted.
Clock output	Clock output path is enabled.

**Table 5: Supported Features for GPIO**

Package	GPIO	LVDS as GPIO
BGA49 BGA81	Schmitt Trigger Variable Drive Strength Pull-up Pull-down Slew Rate	-

During configuration, all GPIO pins are configured in weak pull-up mode.

During user mode, unused GPIO pins are tri-stated and configured in weak pull-up mode. You can change the default mode to weak pull-down in the Interface Designer. No glitches if the GPIO is configured as weak pull-up in user mode



**Note:** Refer to **Table 19: Single-Ended I/O Buffer Drive Strength Characteristics** on page 19 for more information.

### Simple I/O Buffer

**Figure 7: I/O Interface Block**

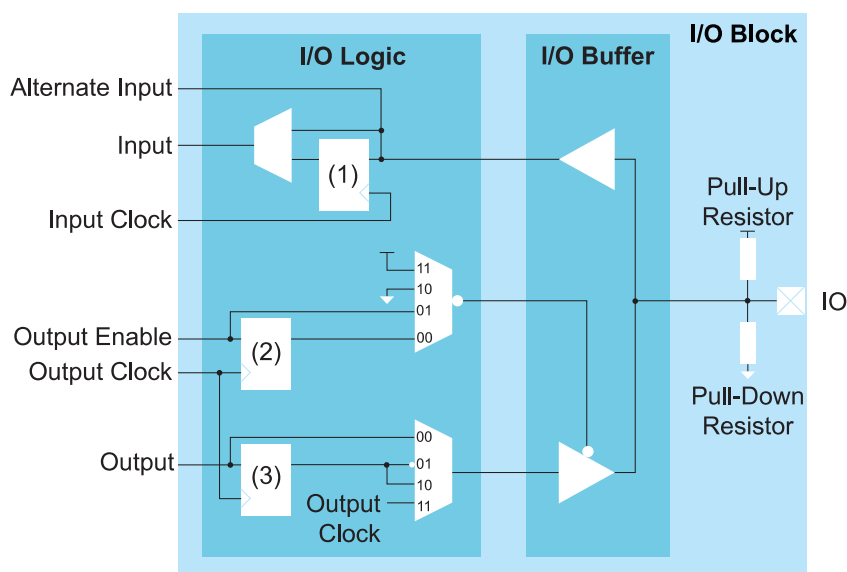

**Notes:**

1. Input Register
2. Output Enable Register
3. Output Register

**Table 6: GPIO Signals**

Signal	Direction	Description
IN	Output	Input data from the GPIO pad to the core fabric.
ALT	Output	Alternative input connection (in the Interface Designer, the input <b>Register Option</b> is none). Alternative connections are GCLK, GCTRL, and PLL_CLKIN.
OUT	Input	Output data to GPIO pad from the core fabric.
OE	Input	Output enable from core fabric to the I/O block. Can be registered.
OUTCLK	Input	Core clock that controls the output and OE register. This clock is not visible in the user netlist.
INCLK	Input	Core clock that controls the input register. This clock is not visible in the user netlist.

**Table 7: GPIO Pads**

Signal	Direction	Description
IO	Bidirectional	GPIO pad.

## I/O Banks

Efnix FPGAs have input/output (I/O) banks for general-purpose usage. Each I/O bank has independent power pins. The number and voltages supported vary by FPGA and package.

**Table 8: I/O Banks by Package**

Package	I/O Banks	Voltage (V)	Banks with DDIO Support	Merged Banks
BGA49, BGA81	1A - 1C, 2A, 2B	1.8, 2.5, 3.3	-	-



**Learn more:** Refer to the [T4 pinout](#) for information on the I/O bank assignments.

## PLL

The T4 has 1 PLL to synthesize clock frequencies. The PLL's reference clock input comes from a dedicated GPIO's alternate input pin. The PLL consists of a pre-divider counter (N counter), a feedback multiplier counter (M counter), post-divider counter (O counter), and an output divider per clock output.

Figure 8: T4 PLL Block Diagram

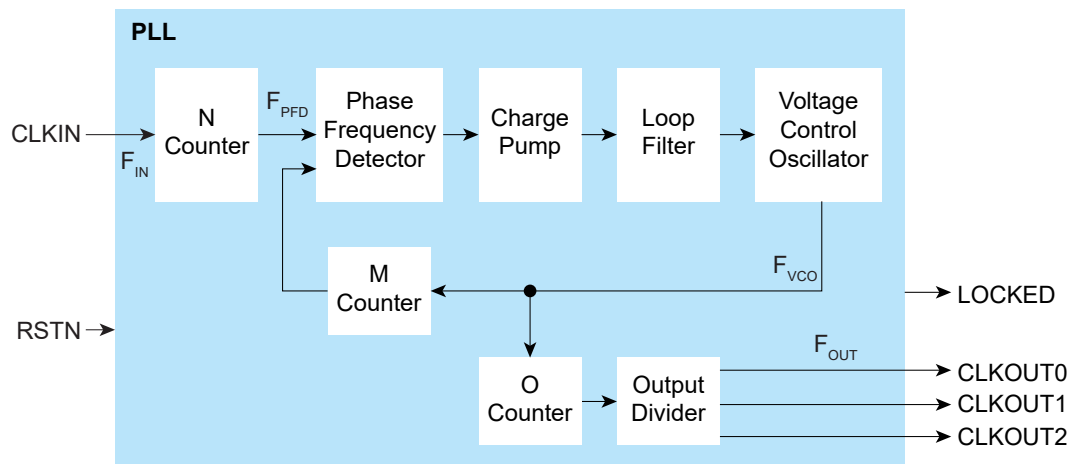

The counter settings define the PLL output frequency:	where:
$F_{PFD} = F_{IN} / N$ $F_{VCO} = F_{PFD} \times M$ $F_{OUT} = F_{VCO} / (O \times \text{Output divider})$	$F_{VCO}$ is the voltage control oscillator frequency $F_{OUT}$ is the output clock frequency $F_{IN}$ is the reference clock frequency $F_{PFD}$ is the phase frequency detector input frequency

**Note:** The reference clock must be between 10 and 50 MHz.  
 The PFD input must be between 10 and 50 MHz.  
 The VCO frequency must be between 500 and 1,200 MHz.

Unlike other Trion® FPGAs, the T4 PLL output locks on the *negative* clock edge (not the positive edge). When you are using two or more clock outputs, they are aligned on the falling edge. If the core register receiving the clock is positive edge triggered, Efinix recommends inverting the clock outputs so they are correctly edge aligned.

Figure 9: PLL Output Aligned with Negative Edge

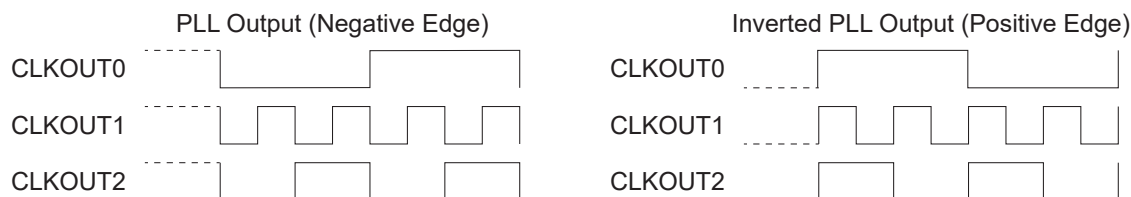

**Table 9: PLL Pins**

Port	Direction	Description
CLKIN	Input	Reference clock. This port is also a GPIO pin; the GPIO pins' alternate function is configured as a reference clock.
RSTN	Input	Active-low PLL reset signal. When asserted, this signal resets the PLL; when de-asserted, it enables the PLL. Connect this signal in your design to power up or reset the PLL. Assert the RSTN pin for a minimum pulse of 10 ns to reset the PLL.
CLKOUT0 CLKOUT1 CLKOUT2	Output	PLL output. The designer can route these signals as input clocks to the core's GCLK network.
LOCKED	Output	Goes high when PLL achieves lock; goes low when a loss of lock is detected. Connect this signal in your design to monitor the lock status. This signal is analog asynchronous.

**Table 10: PLL Settings**

Configure these settings in the Efinity® Interface Designer.

Setting	Allowed Values	Notes
N counter	1 - 15 (integer)	Pre-divider
M counter	1 - 255 (integer)	Multiplier
O counter	1, 2, 4, 8	Post-divider
Output divider	2, 4, 8, 16, 32, 64, 128, 256	Output divider per output

## Oscillator

The T4 has 1 low-frequency oscillator tailored for low-power operation. The oscillator runs at nominal frequency of 10 kHz. Designers can use the oscillator to perform always-on functions with the lowest power possible. Its output clock is available to the GCLK network.

# Power Up Sequence

Efnix® recommends the following power up sequence when powering Trion® FPGAs:

1. Power up VCC and VCCA\_XX first.
2. When VCC and VCCA\_XX are stable, power up all VCCIO pins. There is no specific timing delay between the VCCIO pins.



**Important:** Ensure the power ramp rate is within VCCIO/10 V/ms to 10 V/ms.

3. After all power supplies are stable, hold CRESET\_N low for a duration of  $t_{\text{CRESET\_N}}$  before asserting CRESET\_N from low to high to trigger active SPI programming (the FPGA loads the configuration data from an external flash device).

When you are not using the GPIO or PLL resources, connect the pins as shown in the following table.

*Table 11: Connection Requirements for Unused Resources*

Unused Resource	Pin	Note
GPIO Bank	VCCIOxx	Connect to either 1.8 V, 2.5 V, or 3.3 V.
PLL	VCCA_PLL	Connect to VCC (1.2 V).



**Learn more:** Refer to [Trion Hardware Design Checklist and Guidelines](#) for connection requirements for unused resources.



**Note:** Refer to [Configuration Timing](#) on page 21 for timing information.

*Figure 10: Trion® FPGAs Power Up Sequence*

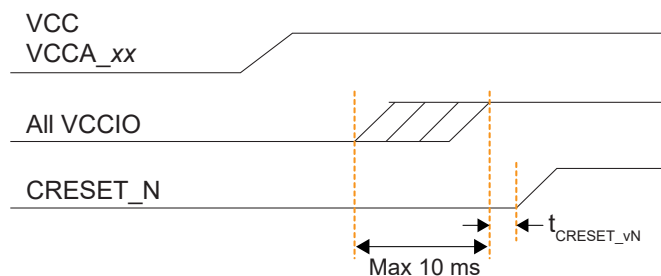

## Power Supply Current Transient

You may observe an inrush current on the dedicated power rail during power-up. You must ensure that the power supplies selected in your board meets the current requirement during power-up and the estimated current during user mode. Use the Power Estimator to calculate the estimated current during user mode.

*Table 12: Maximum Power Supply Current Transient*

<b>Power Supply</b>	<b>Maximum Power Supply Current Transient<sup>(3)(4)</sup></b>	<b>Unit</b>
VCC	18	mA

---

<sup>(3)</sup> Inrush current for other power rails are not significant in Trion® FPGAs.

<sup>(4)</sup> Measured at room temperature.

# Configuration

The T4 FPGA contains volatile Configuration RAM (CRAM). The user must configure the CRAM for the desired logic function upon power-up and before the FPGA enters normal operation. The FPGA's control block manages the configuration process and uses a bitstream to program the CRAM. The Efinity® software generates the bitstream, which is design dependent. You can configure the T4 FPGA(s) in SPI active, SPI passive, or JTAG mode.



**Learn more:** Refer to [AN 006: Configuring Trion FPGAs](#) for details on the dedicated configuration pins and how to configure FPGA(s).

Figure 11: High-Level Configuration Options

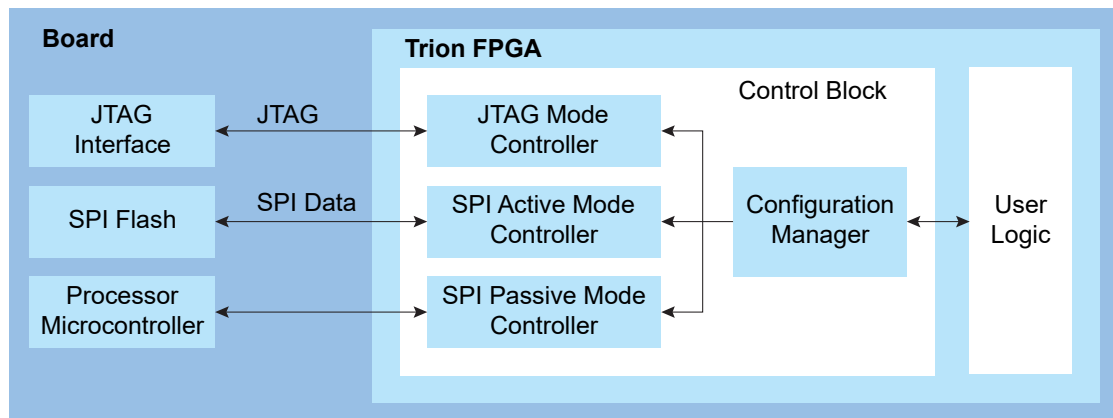

In active mode, the FPGA controls the configuration process. An oscillator circuit within the FPGA provides the configuration clock. The bitstream is typically stored in an external serial flash device, which provides the bitstream when the FPGA requests it.

The control block sends out the instruction and address to read the configuration data. First, it issues a release from power-down instruction to wake up the external SPI flash. Then, it waits for at least 30  $\mu$ s before issuing a fast read command to read the content of SPI flash from address 24h'000000.

In passive mode, the FPGA is the slave and relies on an external master to provide the control, bitstream, and clock for configuration. Typically the master is a microcontroller or another FPGA in active mode.

In JTAG mode, you configure the FPGA via the JTAG interface.

## Supported Configuration Modes

Table 13: T4 Configuration Modes by Package

Configuration Mode	Width	BGA49	BGA81
Active	X1	✓	✓
	X2	✓	✓
	X4	✓	✓
Passive	X1	✓	✓
	X2	✓	✓
	X4	✓	✓
	X8	✓	✓
JTAG	X1		✓

## Mask-Programmable Memory Option

The T4 FPGA is equipped with one-time programmable MPM. With this feature, you use on-chip MPM instead of an external serial flash device to configure the FPGA. This option is for systems that require an ultra-small factor and the lowest cost structure such that an external serial flash device is undesirable and/or not required at volume production. MPM is a one-time factory programmable option that requires a Non-Recurring Engineering (NRE) payment. To enable MPM, submit your design to our factory; our Applications Engineers (AEs) convert your design into a single configuration mask to be specially fabricated.

# DC and Switching Characteristics

**Table 14: Absolute Maximum Ratings** <sup>(5)</sup>

Conditions beyond those listed may cause permanent damage to the device. Device operation at the absolute maximum ratings for extended periods of time has adverse effects on the device.

Symbol	Description	Min	Max	Units
VCC	Core power supply	-0.5	1.42	V
VCCIO	I/O bank power supply	-0.5	4.6	V
VCCA_PLL	PLL analog power supply	-0.5	1.42	V
V <sub>IN</sub>	I/O input voltage	-0.5	4.6	V
I <sub>IN</sub>	Maximum current through any pin in a powered or unpowered bank when forward biasing the clamp diode. <sup>(6)</sup>	-	10	mA
T <sub>J</sub>	Operating junction temperature	-40	125	°C
T <sub>STG</sub>	Storage temperature, ambient	-55	150	°C

**Table 15: Recommended Operating Conditions** <sup>(5)</sup>

Symbol	Description	Min	Typ	Max	Units
VCC	Core power supply	1.05	1.1	1.15	V
VCCIO	1.8 V I/O bank power supply	1.71	1.8	1.89	V
	2.5 V I/O bank power supply	2.38	2.5	2.63	V
	3.3 V I/O bank power supply	3.14	3.3	3.47	V
VCCA_PLL	PLL analog power supply	1.05	1.1	1.15	V
V <sub>IN</sub>	I/O input voltage <sup>(7)</sup>	-0.3	-	VCCIO + 0.3	V
T <sub>JCOM</sub>	Operating junction temperature, commercial	0	-	85	°C
T <sub>JIND</sub>	Operating junction temperature, industrial	-40	-	100	°C

**Table 16: Power Supply Ramp Rates**

Symbol	Description	Min	Max	Units
t <sub>RAMP</sub>	Power supply ramp rate for all supplies.	VCCIO/10	10	V/ms

**Table 17: Single-Ended I/O DC Electrical Characteristics**

I/O Standard	V <sub>IL</sub> (V)		V <sub>IH</sub> (V)		V <sub>OL</sub> (V)	V <sub>OH</sub> (V)
	Min	Max	Min	Max	Max	Min
3.3 V LVCMOS	-0.3	0.8	2	VCCIO + 0.3	0.2	VCCIO - 0.2

<sup>(5)</sup> Supply voltage specification applied to the voltage taken at the device pins with respect to ground, not at the power supply.

<sup>(6)</sup> Should not exceed a total of 120 mA per bank.

<sup>(7)</sup> Values applicable to both input and tri-stated output configuration.

I/O Standard	$V_{IL}$ (V)		$V_{IH}$ (V)		$V_{OL}$ (V)	$V_{OH}$ (V)
	Min	Max	Min	Max	Max	Min
3.3 V LVTTTL	-0.3	0.8	2	$V_{CCIO} + 0.3$	0.4	2.4
2.5 V LVCMOS	-0.3	0.7	1.7	$V_{CCIO} + 0.3$	0.5	1.8
1.8 V LVCMOS	-0.3	$0.35 * V_{CCIO}$	$0.65 * V_{CCIO}$	$V_{CCIO} + 0.3$	0.45	$V_{CCIO} - 0.45$

**Table 18: Single-Ended I/O and Dedicated Configuration Pins Schmitt Trigger Buffer Characteristic**

Voltage	$V_{T+}$ (V) Schmitt Trigger Low-to-High Threshold	$V_{T-}$ (V) Schmitt Trigger High-to-Low Threshold	Input Leakage Current ( $\mu$ A)	Tristate Output Leakage Current ( $\mu$ A)
3.3	1.73	1.32	$\pm 10$	$\pm 10$
2.5	1.37	1.01	$\pm 10$	$\pm 10$
1.8	1.05	0.71	$\pm 10$	$\pm 10$

**Table 19: Single-Ended I/O Buffer Drive Strength Characteristics**

Junction temperature at  $T_J = 25^\circ\text{C}$ , power supply at nominal voltage, device in nominal process (TT).  
CDONE has a drive strength of 1.

I/O Standard	3.3 V		2.5 V		1.8 V	
	$I_{OH}$ (mA)	$I_{OL}$ (mA)	$I_{OH}$ (mA)	$I_{OL}$ (mA)	$I_{OH}$ (mA)	$I_{OL}$ (mA)
1	14.4	8.0	9.1	8.0	5.1	4.4
2	19.1	10.5	12.2	10.5	6.8	5.8
3	23.9	13.3	15.2	13.4	8.6	7.3
4	28.7	15.8	18.2	15.9	10.3	8.6

**Table 20: Single-Ended I/O Internal Weak Pull-Up and Pull-Down Resistance**

CDONE and CRESET\_N also have an internal weak pull-up with these values.

I/O Standard	Internal Pull-Up			Internal Pull-Down			Units
	Min	Typ	Max	Min	Typ	Max	
3.3 V LVTTTL/LVCMOS	27	40	65	30	47	83	$k\Omega$
2.5 V LVCMOS	35	55	95	37	62	118	$k\Omega$
1.8 V LVCMOS	53	90	167	54	99	202	$k\Omega$

**Table 21: Single-Ended I/O Rise and Fall Time**

Data are based on the following IBIS simulation setup:

- Weakest drive strength model
- Typical simulation corner setting
- RLC circuit with 6.6 pF capacitance, 16.6 nH inductance, 0.095 ohm resistance, and 25 °C temperature



**Note:** For a more accurate data, you need to perform the simulation with your own circuit.

I/O Standard	Rise Time ( $T_R$ )		Fall Time ( $T_F$ )		Units
	Slow Slew Rate Enabled	Slow Slew Rate Disabled	Slow Slew Rate Enabled	Slow Slew Rate Disabled	
3.3 V LVTTTL/LVCMOS	1.13	1.02	1.24	1.17	ns
2.5 V LVCMOS	1.4	1.3	1.44	1.31	ns
1.8 V LVCMOS	2.14	2.01	2.05	1.85	ns

**Table 22: Maximum Toggle Rate**

I/O Standard	Maximum Load (pF)	Max Toggle Rate (Mbps)
3.3 V LVTTTL/LVCMOS	10	400
2.5 V LVCMOS	10	400
1.8 V LVCMOS	10	400

**Table 23: Block RAM Characteristics**

Symbol	Description	C2, I2 Speed Grade	Units
$f_{MAX}$	Block RAM maximum frequency.	275	MHz

**Table 24: Multiplier Block Characteristics**

Symbol	Description	C2, I2 Speed Grade	Units
$f_{MAX}$	Multiplier block maximum frequency.	275	MHz

## ESD Performance

Refer to the [Trion Reliability Report](#) for ESD performance data.

# Configuration Timing

The T4 FPGA has the following configuration timing specifications. Refer to [AN 006: Configuring Trion FPGAs](#) for detailed configuration information.

## Timing Waveforms

Figure 12: SPI Active Mode (x1) Timing Sequence

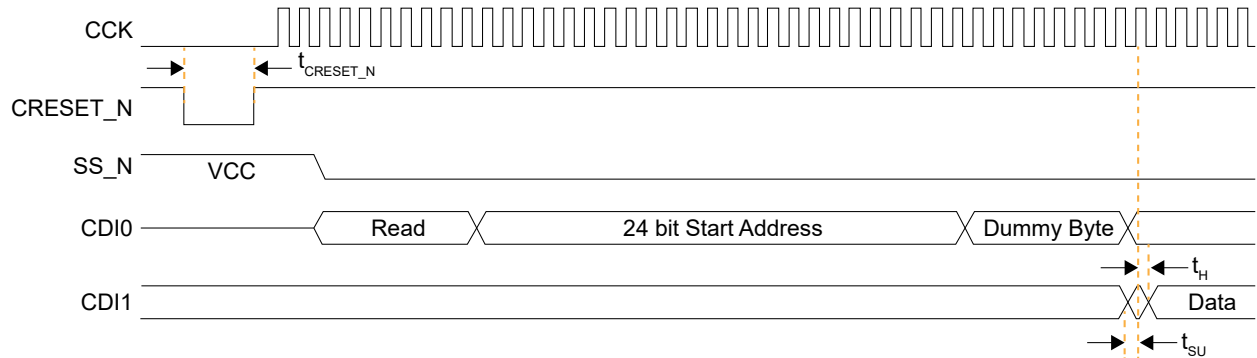

Figure 13: SPI Passive Mode (x1) Timing Sequence

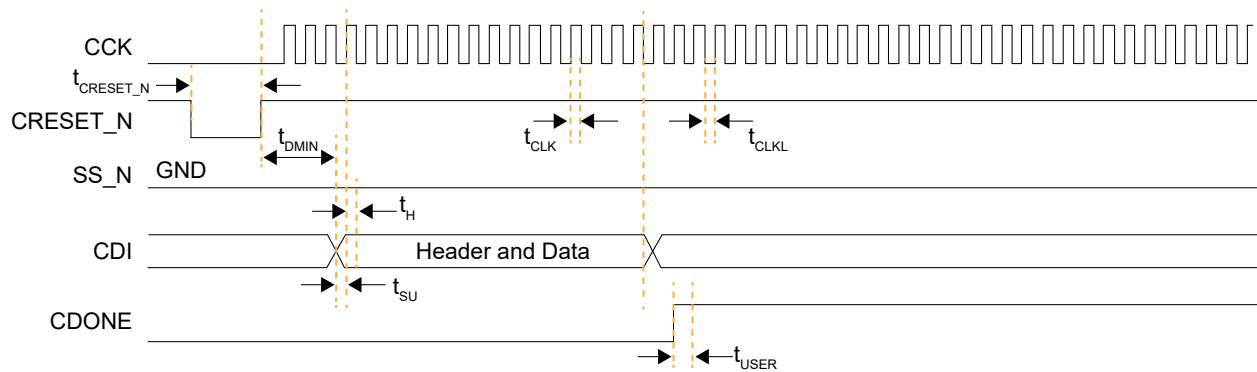
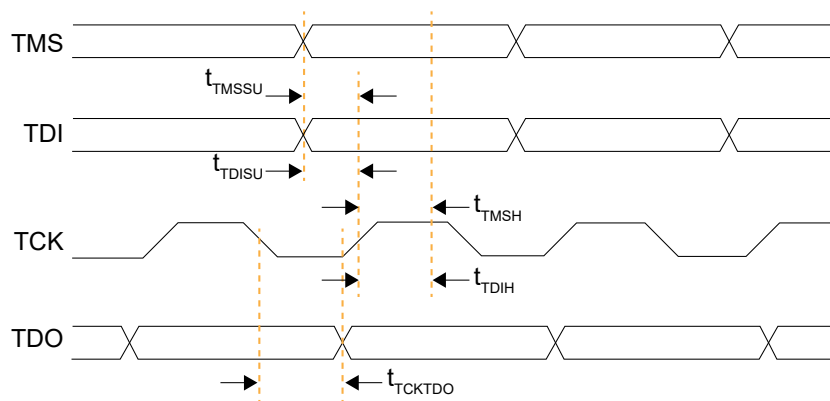

Figure 14: Boundary-Scan Timing Waveform



## Timing Parameters

**Table 25: All Modes**

Symbol	Parameter	Min	Typ	Max	Units
t <sub>CRESET_N</sub>	Minimum creset_n low pulse width required to trigger re-configuration.	320	-	-	ns
t <sub>USER</sub>	Minimum configuration duration after CDONE goes high before entering user mode. <sup>(8)(9)</sup> Test condition at 10 kΩ pull-up resistance and 10 pF output loading on CDONE pin.	12	-	(10)	μs

**Table 26: Active Mode**

Symbol	Parameter	Frequency	Min	Typ	Max	Units
f <sub>MAX_M</sub>	Active mode configuration clock frequency <sup>(11)</sup> .	DIV4	14	20	26	MHz
		DIV8	7	10	13	MHz

**Table 27: Passive Mode**

Symbol	Parameter	Min	Typ	Max	Units
f <sub>MAX_S</sub>	Passive mode X1 configuration clock frequency.	-	-	25	MHz
	Passive mode X2, X4 or X8 configuration clock frequency.	-	-	50	MHz
t <sub>CLKH</sub>	Configuration clock pulse width high.	0.48*1/ f <sub>MAX_S</sub>	-	-	ns
t <sub>CLKL</sub>	Configuration clock pulse width low.	0.48*1/ f <sub>MAX_S</sub>	-	-	ns
t <sub>SU</sub>	Setup time.	4	-	-	ns
t <sub>H</sub>	Hold time.	1	-	-	ns
t <sub>DMIN</sub>	Minimum time between deassertion of CRESET_N to first valid configuration data.	1.2	-	-	μs

**Table 28: JTAG Mode**

Symbol	Parameter	Min	Typ	Max	Units
f <sub>TCK</sub>	TCK frequency.	-	-	25	MHz
t <sub>DISU</sub>	TDI setup time.	3.5	-	-	ns
t <sub>DIH</sub>	TDI hold time.	1	-	-	ns
t <sub>MSSU</sub>	TMS setup time.	3	-	-	ns
t <sub>MSSH</sub>	TMS hold time.	1	-	-	ns
t <sub>CKTDO</sub>	TCK falling edge to TDO output.	-	-	10.5 <sup>(12)</sup>	ns

<sup>(8)</sup> The FPGA may go into user mode before t<sub>USER</sub> has elapsed. However, Efinix recommends that you keep the system interface to the FPGA in reset until t<sub>USER</sub> has elapsed.

<sup>(9)</sup> For JTAG programming, the min t<sub>USER</sub> configuration time is required after CDONE goes high and FPGA receives the ENTERUSER instruction from JTAG host (TAP controller in UPDATE\_IR state).

<sup>(10)</sup> See **Maximum t<sub>USER</sub> for SPI Active and Passive Modes** on page 23

<sup>(11)</sup> For parallel daisy chain x2 and x4, the active configuration clock frequency, f<sub>MAX\_M</sub>, is required to set to DIV4.

<sup>(12)</sup> 0 pf output loading.

## Maximum $t_{USER}$ for SPI Active and Passive Modes

The following waveform illustrates the minimum and maximum values for  $t_{USER}$ .

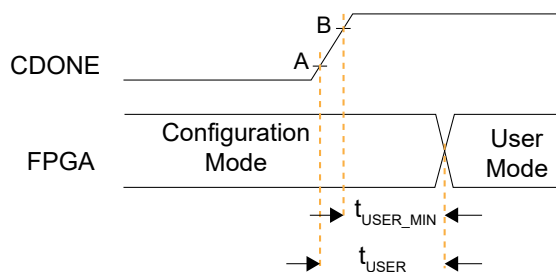

- *Point A*—User-defined trigger point to start counter on  $t_{USER}$
- *Point B*— $V_{IH}$  (with Schmitt Trigger) of Trion I/Os

The maximum  $t_{USER}$  value can be derived based on the following formula:

**Table 29:  $t_{USER}$  Maximum**

Configuration Setup	$t_{USER}$ Maximum
Single Trion FPGA	$t_{USER} = t_{(from\ A\ to\ B)} + t_{USER\_MIN}$
Slave FPGA in a dual-Trion FPGA SPI chain	
Master FPGA in a dual-Trion FPGA SPI chain	$t_{USER} = (1344 / SPI\_WIDTH) * CCK\ period + t_{USER\_MIN} + t_{(from\ A\ to\ B)}$

## PLL Timing and AC Characteristics

The following tables describe the PLL timing and AC characteristics.

**Table 30: PLL Timing**

Symbol	Parameter	Min	Typ	Max	Units
$F_{PFD}$	Phase frequency detector input frequency.	10	-	50	MHz
$F_{OUT}$	Output clock frequency.	0.25	-	400	MHz
$F_{VCO}$	PLL VCO frequency.	500	-	1200	MHz

**Table 31: PLL AC Characteristics**

Symbol	Parameter	Min	Typ	Max	Units
$t_{DT}$	Output clock duty cycle.	40	50	60	%
$t_{OPJIT}$ (PK - PK)	Output clock period jitter (PK-PK).	-	100	-	ps
$t_{INDT}$	Input clock duty cycle.	45	-	55	%
$t_{ILJIT}$ (PK - PK)	Input clock long-term jitter (PK-PK)	-	-	800	ps
$t_{LOCK}$	PLL pull in plus lock-in time.	-	-	0.5	ms

# Internal Oscillator

The internal oscillator has the following specifications.

**Table 32: Internal Oscillator Specifications**

Symbol	Parameter	Min	Typ	Max	Units
F <sub>CLKOSC</sub>	Oscillator clock frequency.	-	10	-	kHz
D <sub>CHOSC</sub>	Duty cycle.	45	50	55	%

# Pinout Description

The following tables describe the pinouts for power, ground, configuration, and interfaces.

**Table 33: General Pinouts**

Function	Group	Direction	Description
VCC	Power	-	Core power supply.
VCCIO	Power	-	I/O pin power supply.
VCCA_PLL	Power	-	PLL analog power supply.
GND	Ground	-	Ground.
GND <sub>A_PLL</sub>	Ground	-	PLL ground pin.
CLK <sub>n</sub>	Alternate	Input	Global clock network input. <i>n</i> is the number. The number of inputs is package dependent.
CTRL <sub>n</sub>	Alternate	Input	Global network input used for high fanout and global reset. <i>n</i> is the number. The number of inputs is package dependent.
PLLIN	Alternate	Input	PLL reference clock.
MREFCLK	Alternate	Input	MIPI PLL reference clock source.
GPIO <sub>x_n</sub>	GPIO	I/O	General-purpose I/O for user function. User I/O pins are single-ended. x: Indicates the bank (L or R) n: Indicates the GPIO number.
GPIO <sub>x_n_yyy</sub> GPIO <sub>x_n_yyy_zzz</sub> GPIO <sub>x_zzzn</sub>	GPIO Multi-Function	I/O	Multi-function, general-purpose I/O. These pins are single ended. If these pins are not used for their alternate function, you can use them as user I/O pins. x: Indicates the bank; left (L) or right (R). n: Indicates the GPIO number. yyy, yyy_zzz: Indicates the alternate function.

**Table 34: Dedicated Configuration Pins**

These pins cannot be used as general-purpose I/O after configuration.

Pins	Direction	Description	Use External Weak Pull-Up
CDONE	I/O	Configuration done status pin. CDONE is an open drain output; connect it to an external pull-up resistor to VCCIO. When CDONE = 1, configuration is complete. If you hold CDONE low, the device will not enter user mode.	✓
CRESET_N	Input	Initiates FPGA re-configuration (active low). Pulse CRESET_N low for a duration of $t_{\text{creset\_N}}$ before asserting CRESET_N from low to high to initiate FPGA re-configuration. This pin does not perform a system reset.	✓
TCK	Input	JTAG test clock input (TCK). The rising edge loads signals applied at the TAP input pins (TMS and TDI). The falling edge clocks out signals through the TAP TDO pin.	✓
TMS	Input	JTAG test mode select input (TMS). The I/O sequence on this input controls the test logic operation. The signal value typically changes on the falling edge of TCK. TMS has an internal weak pull-up; when it is not driven by an external source, the test logic perceives a logic 1.	Recommended
TDI	Input	JTAG test data input (TDI). Data applied at this serial input is fed into the instruction register or into a test data register depending on the sequence previously applied at TMS. Typically, the signal applied at TDI changes state following the falling edge of TCK while the registers shift in the value received on the rising edge. Like TMS, TDI has an internal weak pull-up; when it is not driven from an external source, the test logic perceives a logic 1.	Recommended
TDO	Output	JTAG test data output (TDO). This serial output from the test logic is fed from the instruction register or from a test data register depending on the sequence previously applied at TMS. During shifting, data applied at TDI appears at TDO after a number of cycles of TCK determined by the length of the register included in the serial path. The signal driven through TDO changes state following the falling edge of TCK. When data is not being shifted through the device, TDO is set to an inactive drive state (e.g., high-impedance).	✓



**Note:** All dedicated configuration pins have Schmitt Trigger buffer. See [Table 18: Single-Ended I/O and Dedicated Configuration Pins Schmitt Trigger Buffer Characteristic](#) on page 19 for the Schmitt Trigger buffer specifications.

**Table 35: Dual-Purpose Configuration Pins**

In user mode (after configuration), you can use these dual-purpose pins as general I/O.

Pins	Direction	Description	Use External Weak Pull-Up
CBUS[2:0]	Input	Configuration bus width select. CBUS has an internal weak pull-up. However, Efinix recommends that you use an external pull-up accordingly. See <a href="#">Selecting the Configuration Mode in AN 006: Configuring Trion FPGAs</a>	✓ <sup>(13)</sup>
CBSEL[1:0]	Input	Optional multi-image selection input (if external multi-image configuration mode is enabled).	✓ <sup>(14)</sup>
CCK	I/O	Passive SPI input configuration clock or active SPI output configuration clock (active low). Includes an internal weak pull-up.	Optional <sup>(15)</sup>
CDIn	I/O	<i>n</i> is a number from 0 to 31 depending on the SPI configuration. 0: Passive serial data input or active serial output. 1: Passive serial data output or active serial input. <i>n</i> : Parallel I/O. In multi-bit daisy chain connection, the CDIn (31:0) connects to the data bus in parallel.	Optional <sup>(15)</sup>
CSI	Input	Chip select. 0: The FPGA is not selected or enabled and will not be configured. 1: Selects the FPGA for configuration (SPI and JTAG configuration).	✓
CSO	Output	Chip select output. Selects the next device for cascading configuration.	N/A
NSTATUS	Output	Status (active low). Logic low indicates a configuration error due to ID mismatch.	N/A
SS_N	Input	SPI slave select (active low). Includes an internal weak pull-up resistor to VCCIO during configuration. During configuration, the logic level samples on this pin determine the configuration mode. This pin is an input when sampled at the start of configuration (SS is low); an output in active SPI flash configuration mode. The FPGA senses the value of SS_N when it comes out of reset (pulse CRESET_N low to high). 0: Passive mode 1: Active mode	Optional <sup>(15)</sup>
TEST_N	Input	Active-low test mode enable signal. Set to 1 to disable test mode. During configuration, rely on the external weak pull-up or drive this pin high.	✓
RESERVED_OUT	Output	Reserved pin during user configuration. This pin drives high during user configuration. BGA49 and BGA81 packages only.	N/A

<sup>(13)</sup> Optional for x1 mode.

<sup>(14)</sup> Not applicable to single-image or remote update.

<sup>(15)</sup> Optional unless pull-up is required by external load.

## Efinity Software Support

The Efinity<sup>®</sup> software provides a complete tool flow from RTL design to bitstream generation, including synthesis, place-and-route, and timing analysis. The software has a graphical user interface (GUI) that provides a visual way to set up projects, run the tool flow, and view results. The software also has a command-line flow and Tcl command console. The Efinity<sup>®</sup> software supports simulation flows using the ModelSim, NCSim, or free iVerilog simulators. An integrated hardware Debugger with Logic Analyzer and Virtual I/O debug cores helps you probe signals in your design. The software-generated bitstream file configures the T4 FPGA. The software supports the Verilog HDL and VHDL languages.

## T4 Interface Floorplan



**Note:** The numbers in the floorplan figures indicate the GPIO number ranges. Some packages may not have all GPIO pins in the range bonded out. Refer to the **T4 pinout** for information on which pins are available in each package.

Figure 15: Floorplan Diagram for BGA49 and BGA81 Packages

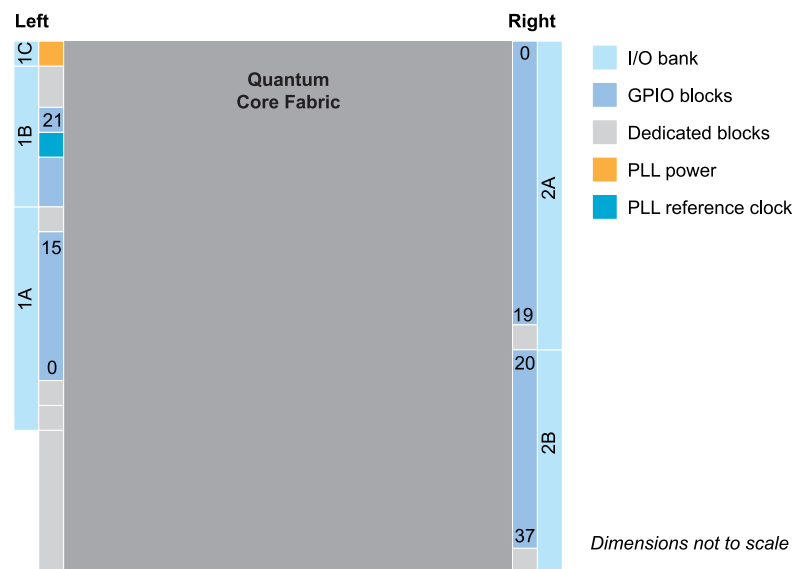

## Ordering Codes

Refer to the **Trion Selector Guide** for the full listing of T4 ordering codes.

# Revision History

**Table 36: Revision History**

Date	Version	Description
February 2023	3.5	Updated power up sequence diagram. (DOC-954)
April 2022	3.4	Updated test condition load to maximum load in Maximum Toggle Rate Table. (DOC-781)
March 2022	3.3	Updated supported maximum VCO frequency to 1,200 MHz. (DOC-722) Updated behaviour description for unused GPIO pins during user mode. (DOC-720) Added note about the block RAM content is random and undefined if it is not initialized. (DOC-729) Updated power supply ramp rate and power up sequence diagram. (DOC-631)
January 2022	3.2	Corrected power supply ramp rate. (DOC-699)
January 2022	3.1	Added maximum I/O pin input current, $I_{IN}$ , and maximum per bank specs. (DOC-652) Added PLL input clock duty cycle, $t_{INDT}$ , specs. (DOC-661) Updated CDONE pin direction as bidirectional. (DOC-672)
November 2021	3.0	Added storage temperature, $T_{STG}$ spec. (DOC-560) Updated maximum JTAG mode TCK frequency, $f_{TCK}$ . (DOC-574) Updated CSI pin description. (DOC-546) Updated $t_{CLKH}$ and $t_{CLKL}$ , and corrected SPI Passive Mode (x1) Timing Sequence waveform. (DOC-590) Updated minimum Power Supply Ramp Rates. (DOC-631) Updated Maximum Toggle Rate table. (DOC-630)
September 2021	2.10	Added Single-Ended I/O Rise and Fall Time specs. (DOC-522) Added note to Active mode configuration clock frequency stating that for parallel daisy chain x2 and x4 configuration, $f_{MAX\_M}$ , must be set to DIV4. (DOC-528) Added Maximum $t_{USER}$ for SPI Active and Passive Modes topic. (DOC-535)
August 2021	2.9	Removed Static Supply Current parameter. (DOC-456) Added internal weak pull-up and pull-down resistor specs. (DOC-485) Added note in Pinout Description stating all dedicated configuration pins have Schmitt Trigger buffer. (DOC-507) Updated table title for Single-Ended I/O Schmitt Trigger Buffer Characteristic. (DOC-507)
June 2021	2.8	Updated CRESET_N pin description. (DOC-450)
April 2021	2.7	Updated PLL specs; $t_{LJIT}$ (PK - PK) and $t_{DT}$ . (DOC-403)
March 2021	2.6	The simple PLL output is negative edge aligned. (DOC-400)
February 2021	2.5	Added I/O input voltage, $V_{IN}$ specification. (DOC-389)

Date	Version	Description
December 2020	2.4	Updated NSTATUS pin description. (DOC-335) Added a table to Power Up Sequence topic describing pin connection when PLL or GPIO is not used. (DOC-325) Updated $f_{MAX\_S}$ for passive configuration modes. (DOC-350)
September 2020	2.3	Updated pinout links.
August 2020	2.2	Removed typical standby (low power [LP] option) from static supply current table and updated typical standby value. Updated $t_{USER}$ timing parameter values and added a note about the conditions for the values. Updated description for GPIO pins state during configuration. Added operating junction temperature for industrial speed grade. Updated block RAM and multiplier block maximum frequencies to include I2 speed grade. Added maximum power supply current transient during power-up.
July 2020	2.1	Updated the term DSP to multiplier. Updated timing parameter symbols in boundary scan timing waveform to reflect JTAG mode parameter symbols. Added supported GPIO features. Updated power up sequence description about holding CRESET_N low. Updated PLLCLK pin name to PLL_CLKIN.
February 2020	2.0	Added $f_{MAX}$ for DSP blocks and RAM blocks. Added Trion power-up sequence. Updated number of global clocks and controls that can come from GPIO pins in package resources table.
December 2019	1.9	Removed DIV1 and DIV2 active mode configuration frequencies; they are not supported.
October 2019	1.8	Added waveforms for configuration timing.
August 2019	1.7	Removed ESD table and added link to Trion Reliability Report. Minor formatting changes.
February 2019	1.6	Removed incorrect footnote about LVDS under Available Package Options.
November 2018	1.5	Updated PLL interface description. Added floorplan information. Updated configuraiton timing and PLL timing information.
August 2018	1.4	Updated configuration pin table. Renamed RST PLL pin as RSTN.
August 2018	1.3	Updated standby current specifications. Updated ordering codes.
July 2018	1.2	<ul style="list-style-type: none"> <li>Updated the PLL timing specification to add <math>F_{PFD}</math>.</li> <li>Clarified the slew rate description.</li> </ul>
May 2018	1.1	Added ordering code information.
April 2018	1.0	Initial release.

## Looking for pricing, stock, or lifecycle information?

Click below to explore more details on WIN SOURCE:

 [View T4F81I2X on WIN SOURCE](#)

 [Efinix, Inc. Information](#)

## Optimize Your Supply Chain with WIN SOURCE Solutions

-  Global Sourcing Solution
-  Obsolete Management
-  Cost Control Management
-  Shortage Management
-  Alternative Solution
-  Excess Inventory Management