



# T35 Data Sheet

---

DST35-v2.0  
November 2021  
[www.efinixinc.com](http://www.efinixinc.com)



# Contents

<b>Introduction.....</b>	<b>4</b>
<b>Features.....</b>	<b>4</b>
Available Package Options.....	5
<b>Device Core Functional Description.....</b>	<b>5</b>
XLR Cell.....	5
Logic Cell.....	6
Embedded Memory.....	6
Multipliers.....	7
Global Clock Network.....	7
Clock and Control Distribution Network.....	8
Global Clock Location.....	8
<b>Device Interface Functional Description.....</b>	<b>10</b>
Interface Block Connectivity.....	10
General-Purpose I/O Logic and Buffer.....	11
Complex I/O Buffer.....	12
Double-Data I/O.....	13
I/O Banks.....	15
PLL.....	15
LVDS.....	20
LVDS TX.....	20
LVDS RX.....	22
MIPI.....	23
MIPI TX.....	24
MIPI RX.....	29
D-PHY Timing Parameters.....	34
DDR DRAM.....	36
DDR Interface Designer Settings.....	40
<b>Power Up Sequence.....</b>	<b>44</b>
Power Supply Current Transient.....	45
<b>Configuration.....</b>	<b>45</b>
Supported Configuration Modes.....	46
<b>DC and Switching Characteristics.....</b>	<b>47</b>
<b>LVDS I/O Electrical and Timing Specifications.....</b>	<b>52</b>
<b>ESD Performance.....</b>	<b>52</b>
<b>MIPI Electrical Specifications and Timing.....</b>	<b>53</b>
MIPI Power-Up Timing.....	54
MIPI Reset Timing.....	54
<b>PLL Timing and AC Characteristics.....</b>	<b>55</b>
<b>Configuration Timing.....</b>	<b>56</b>
Maximum $t_{USER}$ for SPI Active and Passive Modes.....	58
<b>Pinout Description.....</b>	<b>59</b>
<b>Efinity Software Support.....</b>	<b>63</b>

**T35 Interface Floorplan.....63**  
**Ordering Codes..... 64**  
**Revision History.....65**

# Introduction

The T35 FPGA features the high-density, low-power Efinix® Quantum™ architecture wrapped with an I/O interface for easy integration. With a high I/O to logic ratio and differential I/O support, T35 FPGAs supports a variety of applications that need wide I/O connectivity. The T35 also includes a MIPI D-PHY with a built-in, royalty-free CSI-2 controller, which is the most popular camera interface used in the mobile industry. Additionally, T35 FPGAs support a DDR3, LPDDR3, LPDDR2 PHY with memory controller hard IP that provides faster access to data stored in memory. The carefully tailored combination of core resources and I/O provides enhanced capability for applications such as embedded vision, voice and gesture recognition, intelligent sensor hubs, power management, and LED drivers.

## Features

- High-density, low-power Quantum™ architecture
- Built on SMIC 40 nm process
- FPGA interface blocks
  - GPIO
  - PLL
  - LVDS 800 Mbps per lane with up to 20 TX pairs and 26 RX pairs
  - MIPI DPHY with CSI-2 controller hard IP, 1.5 Gbps per lane
  - DDR3, DDR3L, LPDDR3, LPDDR2 x16 PHY (supporting x16 DQ widths) with memory controller hard IP, 25.6 Gbps aggregate bandwidth
- Programmable high-performance I/O
  - Supports 1.8, 2.5, and 3.3 V single-ended I/O standards and interfaces
- Flexible on-chip clocking
  - Low-skew global clock signals can be driven from off-chip external clock signals or PLL synthesized clock signals
  - PLL support
- Flexible device configuration
  - Standard SPI interface (active, passive, and daisy chain)
  - JTAG interface
- Fully supported by the Efinity® software, an RTL-to-bitstream compiler

*Table 1: T35 FPGA Resources*

LEs <sup>(1)</sup>	Global Clock Networks	Global Control Networks	Embedded Memory (kbits)	Embedded Memory Blocks (5 Kbits)	Embedded Multipliers
31,680	Up to 16	Up to 16	1,475	288	120

<sup>(1)</sup> Logic capacity in equivalent LE counts.

Table 2: T35 Package-Dependent Resources<sup>(2)</sup>

Resource	BGA324	BGA400
Available GPIO <sup>(3)</sup>	130	230
Global clocks from GPIO pins	5	16
Global controls from GPIO pins	5	16
PLLs	7	7
LVDS	20 TX pairs 26 RX pairs	20 TX pairs 26 RX pairs
MIPI DPHY with CSI-2 controller (4 data lanes, 1 clock lane)	2 TX blocks 2 RX blocks	-
DDR3, DDR3L, LPDDR3, LPDDR2 PHY with memory controller	1 block (x8 or x16 DQ widths)	1 block (x8 or x16 DQ widths)



**Learn more:** Refer to the [Trion Packaging User Guide](#) for the package outlines and markings.

## Available Package Options

Table 3: Available Packages

Package	Dimensions (mm x mm)	Pitch (mm)
324-ball FBGA	12 x 12	0.65
400-ball FBGA	16 x 16	0.8

## Device Core Functional Description

T35 FPGAs feature an eXchangeable Logic and Routing (XLR) cell that Efinix has optimized for a variety of applications. Trion® FPGAs contain three building blocks constructed from XLR cells: logic elements, embedded memory blocks, and multipliers. Each FPGA in the Trion® family has a custom number of building blocks to fit specific application needs. As shown in the following figure, the FPGA includes I/O ports on all four sides, as well as columns of XLR cells, memory, and multipliers. A control block within the FPGA handles configuration.

### XLR Cell

The eXchangeable Logic and Routing (XLR) cell is the basic building block of the Quantum™ architecture. The Efinix XLR cell combines logic and routing and supports both functions interchangeably. This unique innovation greatly enhances the transistor flexibility and utilization rate, thereby reducing transistor counts and silicon area significantly.

<sup>(2)</sup> Planned packages; subject to change.

<sup>(3)</sup> The LVDS I/O pins are dual-purpose. The full number of GPIO are available when all LVDS I/O pins are in GPIO mode. GPIO and LVDS as GPIO supports different features. See [Table 9: Supported Features for GPIO and LVDS as GPIO](#) on page 12.

## Logic Cell

The logic cell comprises a 4-input LUT or a full adder plus a register (flipflop). You can program each LUT as any combinational logic function with four inputs. You can configure multiple logic cells to implement arithmetic functions such as adders, subtractors, and counters.

Figure 1: Logic Cell Block Diagram

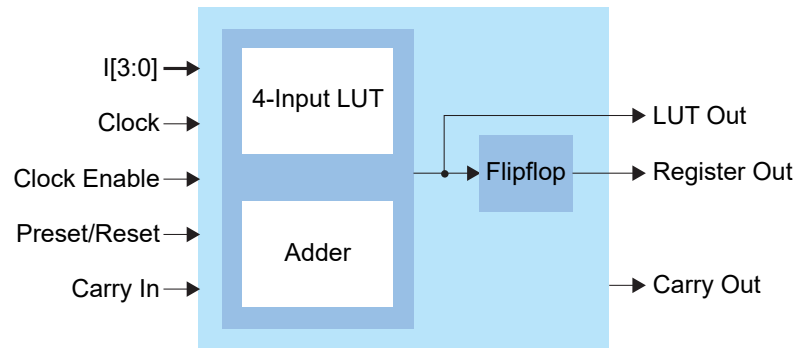

## Embedded Memory

The core has 5-kbit high-speed, synchronous, embedded SRAM memory blocks. Memory blocks can operate as single-port RAM, simple dual-port RAM, true dual-port RAM, FIFOs, or ROM. You can initialize the memory content during configuration. The Efinity<sup>®</sup> software includes a memory cascading feature to connect multiple blocks automatically to form a larger array. This feature enables you to instantiate deeper or wider memory modules.

The memory read and write ports have the following modes for addressing the memory (depth x width):

256 x 16	1024 x 4	4096 x 1	512 x 10
512 x 8	2048 x 2	256 x 20	1024 x 5

The read and write ports support independently configured data widths.

Figure 2: Embedded Memory Block Diagram (True Dual-Port Mode)

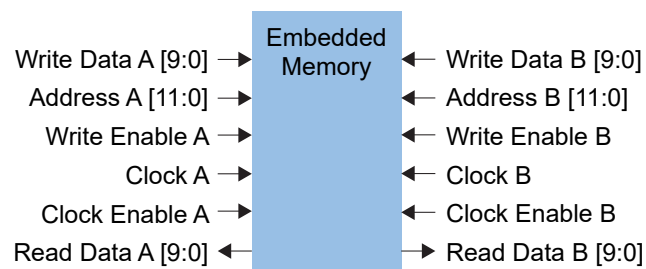

## Multipliers

The FPGA has high-performance multipliers that support 18 x 18 fixed-point multiplication. Each multiplier takes two signed 18-bit input operands and generates a signed 36-bit output product. The multiplier has optional registers on the input and output ports.

*Figure 3: Multiplier Block Diagram*

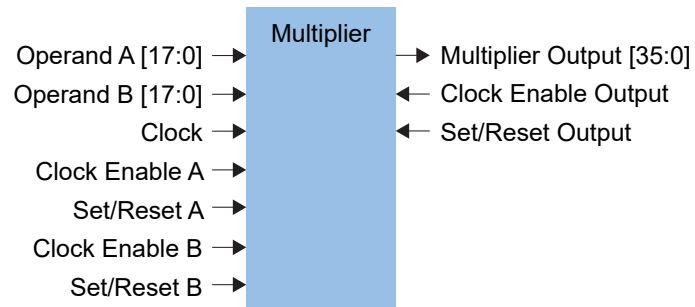

## Global Clock Network

The global clock networks are balanced clock trees that feed all FPGA modules. Each network has dedicated clock-enable logic to save power by disabling the clock tree at the root. The logic dynamically enables/disables the network and guarantees no glitches at the output.

*Figure 4: Global Clock Network*

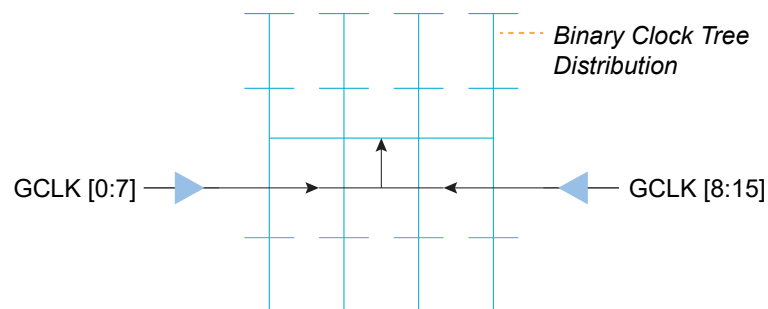

## Clock and Control Distribution Network

The global clock network is distributed through the device to provide clocking for the core's LEs, memory, multipliers, and I/O blocks. Designers can access the T35 global clock network using the global clock GPIO pins, PLL outputs, and core-generated clocks. Similarly, the T35 has GPIO pins (the number varies by package) that the designer can configure as control inputs to access the high-fanout network connected to the LE's set, reset, and clock enable signals.



**Learn more:** Refer to the [T35 Pinout](#) for information on the location and names of these pins.

### Global Clock Location

The following tables describe the location of the global clock signals in T35 FPGAs.

**Table 4: Left Clock Input from GPIO Pins**

Function Name	Resource Name	GCLK[0]	GCLK[1]	GCLK[2]	GCLK[3]	GCLK[4]	GCLK[5]	GCLK[6]	GCLK[7]
CLK0	GPIOL_66	✓	-	-	-	✓	-	-	-
CLK1	GPIOL_67	-	✓	-	-	-	✓	-	-
CLK2	GPIOL_68	-	-	✓	-	-	-	✓	-
CLK3	GPIOL_69	-	-	-	✓	-	-	-	✓
CLK4	GPIOL_70	✓	-	-	-	✓	-	-	-
CLK5	GPIOL_71	-	✓	-	-	-	✓	-	-
CLK6	GPIOL_72	-	-	✓	-	-	-	✓	-
CLK7	GPIOL_73	-	-	-	✓	-	-	-	✓

**Table 5: Left Clock from PLL OUTCLK Signal**

PLL Reference	CLKOUT	GCLK[0]	GCLK[1]	GCLK[2]	GCLK[3]	GCLK[4]	GCLK[5]	GCLK[6]	GCLK[7]
PLL_BL0	CLKOUT0	✓	-	-	✓	-	-	-	✓
	CLKOUT1	-	✓	-	-	✓	-	✓	-
	CLKOUT2	-	-	✓	-	-	✓	-	-

Table 6: Right Clock Input from GPIO Pins

Function Name	Resource Name	GCLK[8]	GCLK[9]	GCLK[10]	GCLK[11]	GCLK[12]	GCLK[13]	GCLK[14]	GCLK[15]
CLK0	GPIOR_133	✓	-	-	-	-	-	-	-
CLK1	GPIOR_132	-	✓	-	-	-	-	-	-
CLK2	GPIOR_131	-	-	✓	-	-	-	-	-
CLK3	GPIOR_130	-	-	-	✓	-	-	-	-
CLK4	GPIOR_129	-	-	-	-	✓	-	-	-
CLK5	GPIOR_128	-	-	-	-	-	✓	-	-
CLK6	GPIOR_127	-	-	-	-	-	-	✓	-
CLK7	GPIOR_126	-	-	-	-	-	-	-	✓

Table 7: Right Clock from PLL OUTCLK Signal

PLL Reference	CLKOUT	GCLK[8]	GCLK[9]	GCLK[10]	GCLK[11]	GCLK[12]	GCLK[13]	GCLK[14]	GCLK[15]
PLL_TR0	CLKOUT0	✓	-	-	-	-	-	✓	-
	CLKOUT1	-	✓	✓	-	-	-	-	-
	CLKOUT2	-	✓	✓	-	-	-	-	-
PLL_TR1	CLKOUT0	✓	-	-	✓	-	-	-	-
	CLKOUT1	-	-	-	-	✓	✓	-	-
	CLKOUT2	-	-	-	-	✓	✓	-	-
PLL_TR2	CLKOUT0	✓	-	-	-	-	-	-	✓
	CLKOUT1	-	✓	✓	-	-	-	-	-
	CLKOUT2	-	✓	✓	-	-	-	-	-
PLL_BR0	CLKOUT0	-	-	-	✓	-	-	-	✓
	CLKOUT1	-	-	-	-	✓	✓	-	-
	CLKOUT2	-	-	-	-	✓	✓	-	-
PLL_BR1	CLKOUT0	-	-	✓	-	-	-	✓	-
	CLKOUT1	-	-	-	✓	✓	-	-	-
	CLKOUT2	-	-	-	✓	✓	-	-	-
PLL_BR2	CLKOUT0	-	-	-	-	-	✓	-	-
	CLKOUT1	-	✓	-	-	-	-	✓	-
	CLKOUT2	-	-	-	-	-	-	-	✓

# Device Interface Functional Description

The device interface wraps the core and routes signals between the core and the device I/O pads through a signal interface. Because they use the flexible Quantum™ architecture, devices in the Trion® family support a variety of interfaces to meet the needs of different applications.



**Learn more:** The following sections describe the available device interface features in T35 FPGAs. Refer to the [Trion® Interfaces User Guide](#) for details on the Efinity® Interface Designer settings.

## Interface Block Connectivity

The FPGA core fabric connects to the interface blocks through a signal interface. The interface blocks then connect to the package pins. The core connects to the interface blocks using three types of signals:

- *Input*—Input data or clock to the FPGA core
- *Output*—Output from the FPGA core
- *Clock output*—Clock signal from the core clock tree

*Figure 5: Interface Block and Core Connectivity*

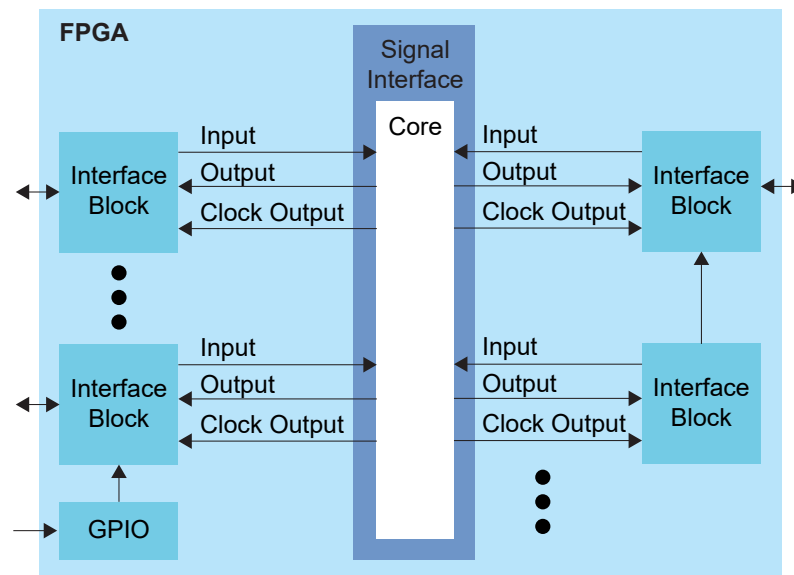

GPIO blocks are a special case because they can operate in several modes. For example, in alternate mode the GPIO signal can bypass the signal interface and directly feed another interface block. So a GPIO configured as an alternate input can be used as a PLL reference clock without going through the signal interface to the core.

When designing for Trion® FPGAs, you create an RTL design for the core and also configure the interface blocks. From the perspective of the core, outputs from the core are inputs to the interface block and inputs to the core are outputs from the interface block.

The Efinity netlist always shows signals from the perspective of the core, so some signals do not appear in the netlist:

- GPIO used as reference clocks are not present in the RTL design, they are only visible in the interface block configuration of the Efinity® Interface Designer.
- The FPGA clock tree is connected to the interface blocks directly. Therefore, clock outputs from the core to the interface are not present in the RTL design, they are only part of the interface configuration (this includes GPIO configured as output clocks).

The following sections describe the different types of interface blocks in the T35. Signals and block diagrams are shown from the perspective of the interface, not the core.

## General-Purpose I/O Logic and Buffer

The GPIO support the 3.3 V LVTTL and 1.8 V, 2.5 V, and 3.3 V LVCMOS I/O standards. The GPIOs are grouped into banks. Each bank has its own VCCIO that sets the bank voltage for the I/O standard.

Each GPIO consists of I/O logic and an I/O buffer. I/O logic connects the core logic to the I/O buffers. I/O buffers are located at the periphery of the device.

The I/O logic comprises three register types:

- *Input*—Capture interface signals from the I/O before being transferred to the core logic
- *Output*—Register signals from the core logic before being transferred to the I/O buffers
- *Output enable*—Enable and disable the I/O buffers when I/O used as output

**Table 8: GPIO Modes**

GPIO Mode	Description
Input	Only the input path is enabled; optionally registered. If registered, the input path uses the input clock to control the registers (positively or negatively triggered). Select the alternate input path to drive the alternate function of the GPIO. The alternate path cannot be registered. In DDIO mode, two registers sample the data on the positive and negative edges of the input clock, creating two data streams.
Output	Only the output path is enabled; optionally registered. If registered, the output path uses the output clock to control the registers (positively or negatively triggered). The output register can be inverted. In DDIO mode, two registers capture the data on the positive and negative edges of the output clock, multiplexing them into one data stream.
Bidirectional	The input, output, and OE paths are enabled; optionally registered. If registered, the input clock controls the input register, the output clock controls the output and OE registers. All registers can be positively or negatively triggered. Additionally, the input and output paths can be registered independently. The output register can be inverted.
Clock output	Clock output path is enabled.

**Table 9: Supported Features for GPIO and LVDS as GPIO**

LVDS as GPIO are LVDS pins that act as GPIOs instead of the LVDS function.

Package	GPIO	LVDS as GPIO
BGA324 BGA400	DDIO Schmitt Trigger Variable Drive Strength Pull-up Pull-down Slew Rate	Variable Drive Strength Pull-up Slew Rate



**Important:** Efinix® recommends that you limit the number of LVDS as GPIO set as output and bidirectional to 14 per bank to avoid switching noise. The Efinity software issues a warning if you exceed the recommended limit.

During configuration, all GPIO pins excluding LVDS as GPIO are configured in weak pull-up mode.

During user mode, unused GPIO pins are tri-stated and configured in weak pull-up mode. You can change the default mode to weak pull-down in the Interface Designer.

### Complex I/O Buffer

Figure 6: I/O Interface Block

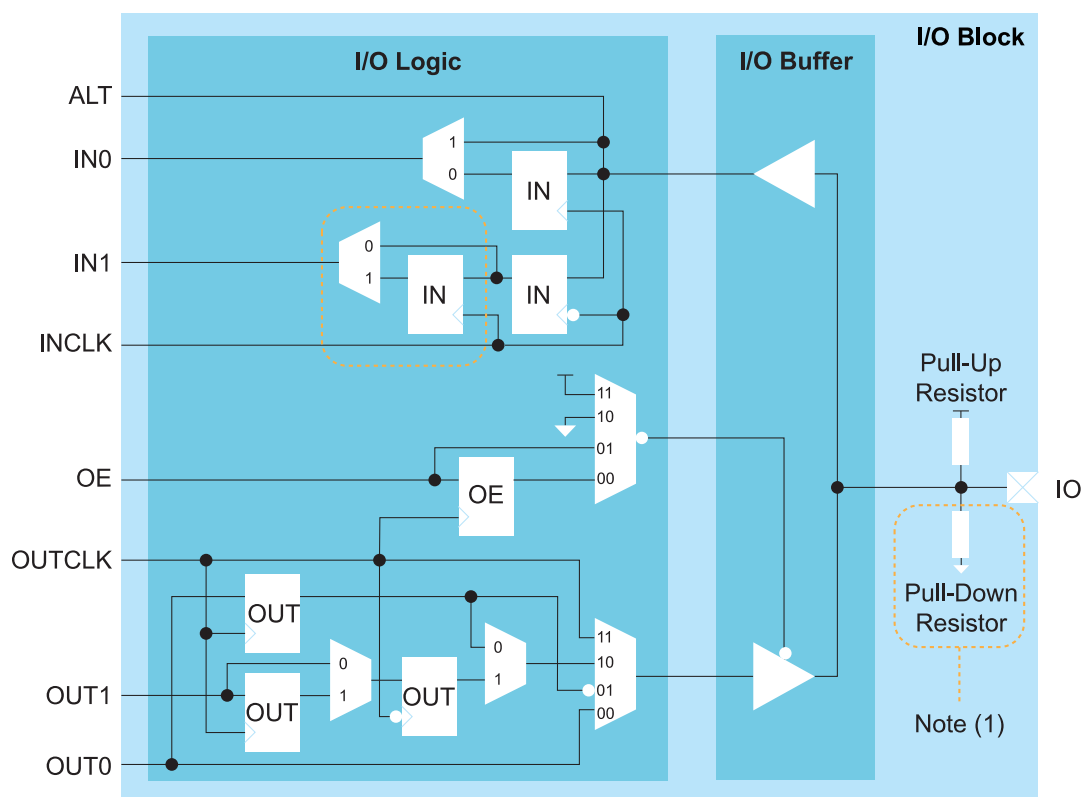

1. GPIO pins using LVDS resources do not have a pull-down resistor.



**Note:** LVDS as GPIO do not have double data I/O (DDIO).

**Table 10: GPIO Signals (Interface to FPGA Fabric)**

Signal	Direction	Description
IN[1:0]	Output	Input data from the GPIO pad to the core fabric. IN0 is the normal input to the core. In DDIO mode, IN0 is the data captured on the positive clock edge (HI pin name in the Interface Designer) and IN1 is the data captured on the negative clock edge (LO pin name in the Interface Designer).
ALT	Output	Alternative input connection (in the Interface Designer, <b>Register Option is none</b> ). Alternative connections are GCLK, GCTRL, PLL_CLKIN, MIPI_CLKIN. <sup>(4)</sup>
OUT[1:0]	Input	Output data to GPIO pad from the core fabric. OUT0 is the normal output from the core. In DDIO mode, OUT0 is the data captured on the positive clock edge (HI pin name in the Interface Designer) and OUT1 is the data captured on the negative clock edge (LO pin name in the Interface Designer).
OE	Input	Output enable from core fabric to the I/O block. Can be registered.
OUTCLK	Input	Core clock that controls the output and OE registers. This clock is not visible in the user netlist.
INCLK	Input	Core clock that controls the input registers. This clock is not visible in the user netlist.

**Table 11: GPIO Pads**

Signal	Direction	Description
IO	Bidirectional	GPIO pad.

### Double-Data I/O

T35 FPGAs support double data I/O (DDIO) on input and output registers. In this mode, the DDIO register captures data on both positive and negative clock edges. The core receives 2 bit wide data from the interface.

In normal mode, the interface receives or sends data directly to or from the core on the positive and negative clock edges. In resync mode, the interface resynchronizes the data to pass both signals on the positive clock edge only.

LVDS as GPIO (that is, single ended I/O) do not support DDIO functionality.

<sup>(4)</sup> MIPI\_CLKIN is only available in packages that support MIPI.

Figure 7: DDIO Input Timing Waveform

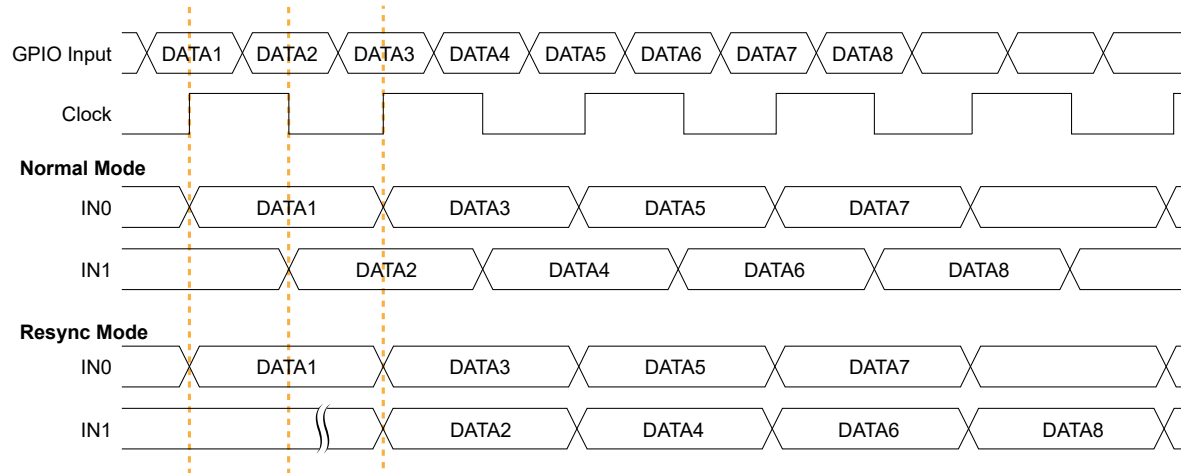

In resync mode, the IN1 data captured on the falling clock edge is delayed one half clock cycle.

In the Interface Designer, IN0 is the HI pin name and IN1 is the LO pin name.

Figure 8: DDIO Output Timing Waveform

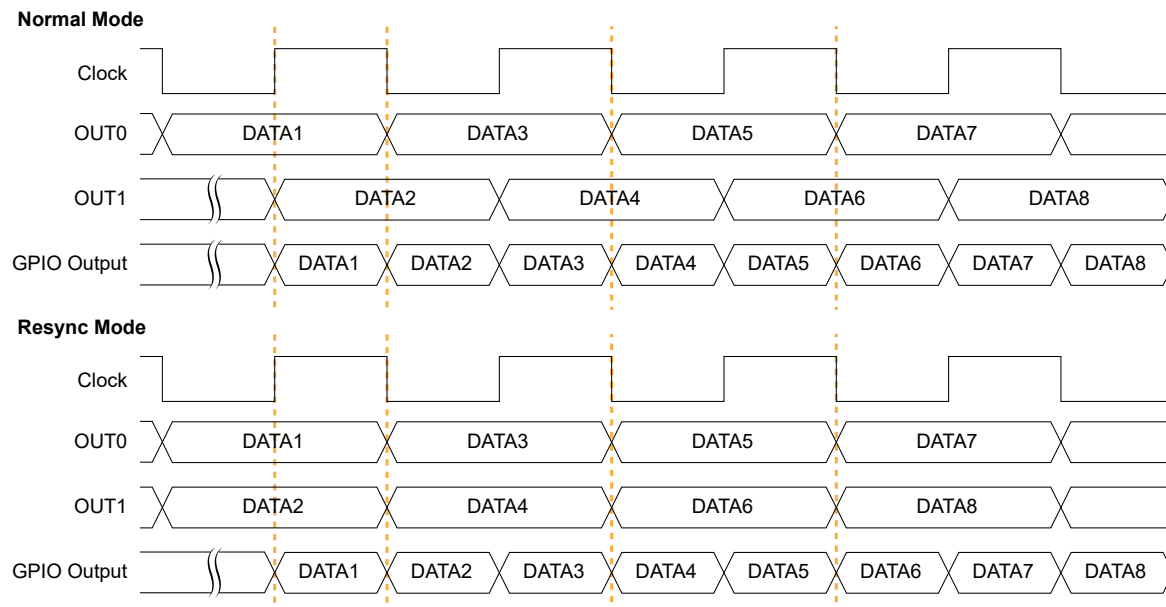

In the Interface Designer, OUT0 is the HI pin name and OUT1 is the LO pin name.

## I/O Banks

Efnix FPGAs have input/output (I/O) banks for general-purpose usage. Each I/O bank has independent power pins. The number and voltages supported vary by FPGA and package.

The number of banks and the voltages they support vary by package.

Some I/O banks are merged at the package level by sharing VCCIO pins. Merged banks have underscores ( \_ ) between banks in the name (e.g., 1B\_1C means 1B and 1C are connected).

**Table 12: I/O Banks by Package**

Package	I/O Banks	Voltage (V)	Banks with DDIO Support	Merged Banks
BGA324	1A - 1E, 2A - 2C, 3A - 3C, 4A, 4B, TR, BR	1.8, 2.5, 3.3	1A - 1E, 3C, TR, BR	1B_1C, 1D_1E
BGA400	1A - 1E, 2A - 2C, 3C, 4A, 4B, TR, BR	1.8, 2.5, 3.3	1A - 1E, 3C, TR, BR	3C_TR



**Learn more:** Refer to the [T35 Pinout](#) for information on the I/O bank assignments.

## PLL

The T35 has 5 or 7 available PLLs (depending on the package) to synthesize clock frequencies.

You can use the PLL to compensate for clock skew/delay via external or internal feedback to meet timing requirements in advanced application. The PLL reference clock has up to four sources. You can dynamically select the PLL reference clock with the CLKSEL port. (Hold the PLL in reset when dynamically selecting the reference clock source.)

The PLL consists of a pre-divider counter (N counter), a feedback multiplier counter (M counter), a post-divider counter (O counter), and output divider.



**Note:** Refer to [T35 Interface Floorplan](#) on page 63 for the location of the PLLs on the die. Refer to [Table 92: General Pinouts](#) on page 59 for the PLL reference clock resource assignment.

Figure 9: PLL Block Diagram

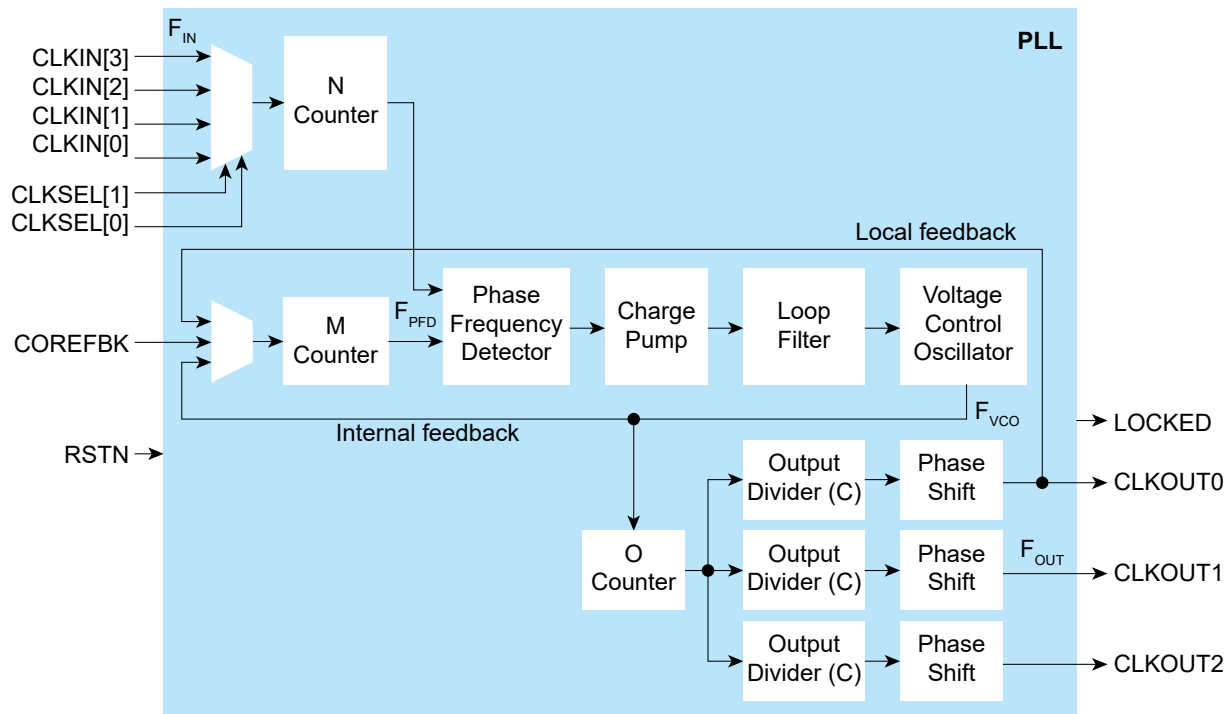

The counter settings define the PLL output frequency:

Internal Feedback Mode	Local and Core Feedback Mode	Where:
$F_{PFD} = F_{IN} / N$ $F_{VCO} = F_{PFD} \times M$ $F_{OUT} = (F_{IN} \times M) / (N \times O \times C)$	$F_{PFD} = F_{IN} / N$ $F_{VCO} = (F_{PFD} \times M \times O \times C_{FBK})^{(5)}$ $F_{OUT} = (F_{IN} \times M \times C_{FBK}) / (N \times C)$	$F_{VCO}$ is the voltage control oscillator frequency $F_{OUT}$ is the output clock frequency $F_{IN}$ is the reference clock frequency $F_{PFD}$ is the phase frequency detector input frequency $C$ is the output divider

**Note:**  $F_{IN}$  must be within the values stated in [PLL Timing and AC Characteristics](#) on page 55.

Figure 10: PLL Interface Block Diagram

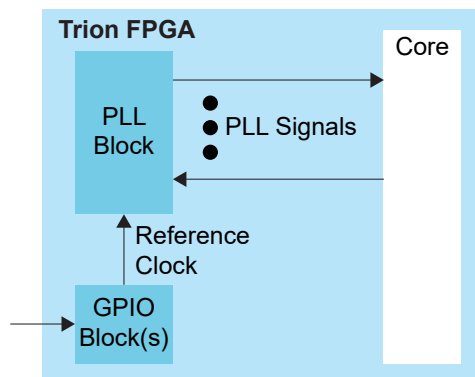

<sup>(5)</sup>  $(M \times O \times C_{FBK})$  must be  $\leq 255$ .

**Table 13: PLL Signals (Interface to FPGA Fabric)**

Signal	Direction	Description
CLKIN[3:0]	Input	Reference clocks driven by I/O pads or core clock tree.
CLKSEL[1:0]	Input	You can dynamically select the reference clock from one of the clock in pins.
RSTN	Input	Active-low PLL reset signal. When asserted, this signal resets the PLL; when de-asserted, it enables the PLL. Connect this signal in your design to power up or reset the PLL. Assert the RSTN pin for a minimum pulse of 10 ns to reset the PLL. Assert RSTN when dynamically changing the selected PLL reference clock.
COREFBK	Input	Connect to a clock out interface pin when the the PLL feedback mode is set to core.
CLKOUT0 CLKOUT1 CLKOUT2	Output	PLL output. The designer can route these signals as input clocks to the core's GCLK network.
LOCKED	Output	Goes high when PLL achieves lock; goes low when a loss of lock is detected. Connect this signal in your design to monitor the lock status.

**Table 14: PLL Interface Designer Settings - Properties Tab**

Parameter	Choices	Notes
Instance Name	User defined	
PLL Resource		The resource listing depends on the FPGA you choose.
Clock Source	External	PLL reference clock comes from an external pin.
	Dynamic	PLL reference clock comes from an external pin or the core, and is controlled by the clock select bus.
	Core	PLL reference clock comes from the core.
Automated Clock Calculation		Pressing this button launches the PLL Clock Calculation window. The calculator helps you define PLL settings in an easy-to-use graphical interface.

**Table 15: PLL Interface Designer Settings - Manual Configuration Tab**

Parameter	Choices	Notes
Reset Pin Name	User defined	
Locked Pin Name	User defined	
Feedback Mode	Internal	PLL feedback is internal to the PLL resulting in no known phase relationship between clock in and clock out.
	Local	PLL feedback is local to the PLL. Aligns the clock out phase with clock in.
	Core	PLL feedback is from the core. The feedback clock is defined by the COREFBK connection, and must be one of the three PLL output clocks. Aligns the clock out phase with clock in and removes the core clock delay.
Reference clock Frequency (MHz)	User defined	
Multiplier (M)	1 - 255 (integer)	M counter.
Pre Divider (N)	1 - 15 (integer)	N counter.
Post Divider (O)	1, 2, 4, 8	O counter.
Clock 0, Clock 1, Clock 2	On, off	Use these checkboxes to enable or disable clock 0, 1, and 2.
Pin Name	User defined	Specify the pin name for clock 0, 1, or 2.
Divider (C)	1 to 256	Output divider.
Phase Shift (Degree)	0, 45, 90, 135, 180, or 270	Phase shift CLKOUT by 0, 45, 90, 135, 180, or 270 degrees. 180, and 270 require the C divider to be 2. 45 and 135 require the C divider to be 4. 90 requires the C divider to be 2 or 4. To phase shift 225 degrees, select 45 and invert the clock at the destination. To phase shift 315 degrees, select 135 and invert the clock at the destination.
Use as Feedback	On, off	

**Table 16: PLL Reference Clock Resource Assignments (BGA324)**

PLL	REFCLK0	REFCLK1
PLL_BL0	GPIOL_15_PLLIN0	N/A
PLL_BR0 <sup>(6)</sup>	GPIOR_138_PLLIN0	Single-ended: GPIOB_TXP09_CLK0
PLL_BR1	GPIOR_139_PLLIN1	Single-ended: GPIOB_TXP15_CLK1_CDI15
PLL_BR2	GPIOR_140_PLLIN2	Single-ended: GPIOB_TXP19_CLK2
PLL_TR0	GPIOR_118_PLLIN0	Differential: GPIOT_RXP08_CLKP0, GPIOT_RXN08_CLKN0 Single-ended: GPIOT_RXP08_CLKP0
PLL_TR1	GPIOR_119_PLLIN0	Differential: GPIOT_RXP17_CLKP1, GPIOT_RXN17_CLKN1 Single-ended: GPIOT_RXP17_CLKP1
PLL_TR2	GPIOR_120_PLLIN0	Differential: GPIOT_RXP25_CLKP2, GPIOT_RXN25_CLKN2 Single-ended: GPIOT_RXP25_CLKP2

**Table 17: PLL Reference Clock Resource Assignments (BGA400)**

PLL	REFCLK0	REFCLK1
PLL_BL0	GPIOL_15_PLLIN0	GPIOL_19_PLLN1
PLL_BR0 <sup>(7)</sup>	GPIOR_138_PLLIN0	Single-ended: GPIOB_TXP09_CLK0
PLL_BR1	GPIOR_139_PLLIN1	Single-ended: GPIOB_TXP15_CLK1_CDI15
PLL_BR2	GPIOR_140_PLLIN2	Single-ended: GPIOB_TXP19_CLK2
PLL_TR0	GPIOR_118_PLLIN0	Differential: GPIOT_RXP08_CLKP0, GPIOT_RXN08_CLKN0 Single-ended: GPIOT_RXP08_CLKP0
PLL_TR1	GPIOR_119_PLLIN0	Differential: GPIOT_RXP17_CLKP1, GPIOT_RXN17_CLKN1 Single-ended: GPIOT_RXP17_CLKP1
PLL_TR2	GPIOR_120_PLLIN0	Differential: GPIOT_RXP25_CLKP2, GPIOT_RXN25_CLKN2 Single-ended: GPIOT_RXP25_CLKP2

<sup>(6)</sup> PLL\_BR0 can be used as the PHY clock for DDR DRAM block.

<sup>(7)</sup> PLL\_BR0 can be used as the PHY clock for DDR DRAM block.

## LVDS

The LVDS hard IP transmitters and receivers operate independently.

- LVDS TX consists of LVDS transmitter and serializer logic.
- LVDS RX consists of LVDS receiver, on-die termination, and de-serializer logic.

The T35 has up to three PLLs for use with the LVDS receiver.

The LVDS hard IP has these features:

- Supports serialization and deserialization factors: 8:1, 7:1, 6:1, 5:1, 4:1, 3:1, and 2:1
- Ability to disable serialization and deserialization
- Source synchronous clock output edge-aligned with data for LVDS transmitter and receiver
- 100  $\Omega$  on-die termination resistor for the LVDS receiver



**Note:** The LVDS RX supports the sub-lvds, slvs, HiVcm, RSDS and 3.3 V LVPECL differential I/O standards with a transfer rate of up to 800 Mbps.

### LVDS TX

Figure 11: LVDS TX Interface Block Diagram

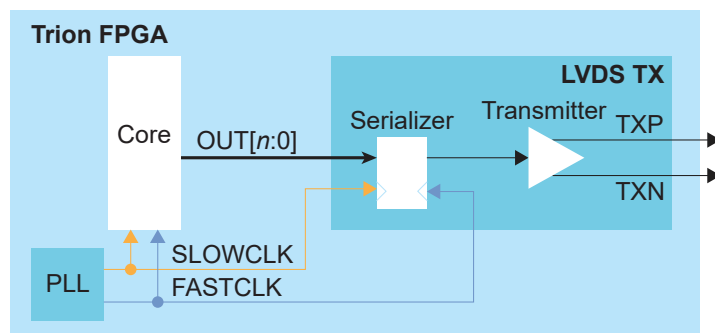

Table 18: LVDS TX Signals (Interface to FPGA Fabric)

Signal	Direction	Notes
OUT[n-1:0]	Input	Parallel output data where $n$ is the serialization factor. A width of 1 bypasses the serializer.
FASTCLK	Input	Fast clock to serialize the data to the LVDS pads.
SLOWCLK	Input	Slow clock to latch the incoming data from the core.

Table 19: LVDS TX Pads

Pad	Direction	Description
TXP	Output	Differential P pad.
TXN	Output	Differential N pad.

The following waveform shows the relationship between the fast clock, slow clock, TX data going to the pad, and byte-aligned data from the core.

Figure 12: LVDS Timing Example Serialization Width of 8

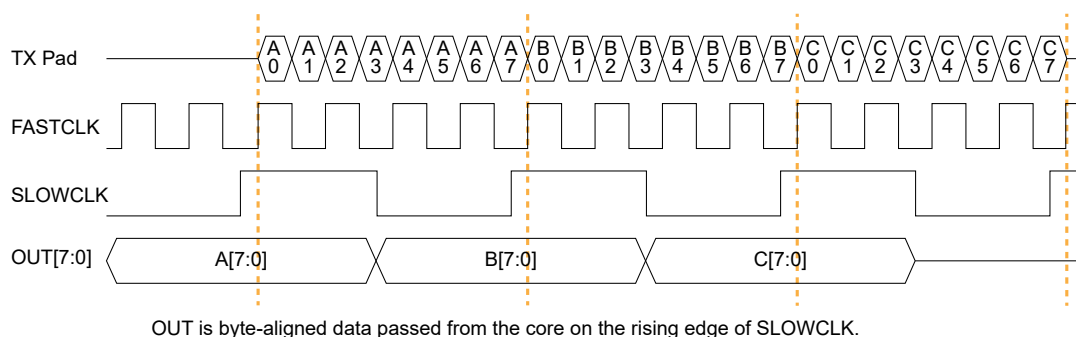

Figure 13: LVDS Timing Data and Clock Relationship Width of 8 (Parallel Clock Division=1)

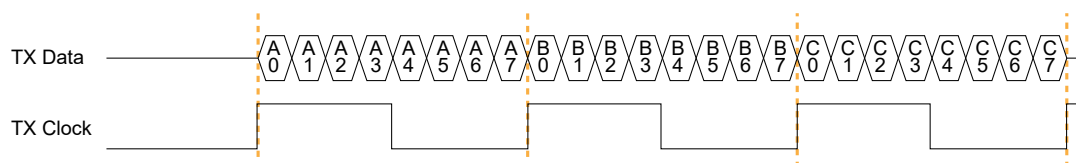

Figure 14: LVDS Timing Data and Clock Relationship Width of 7 (Parallel Clock Division=1)

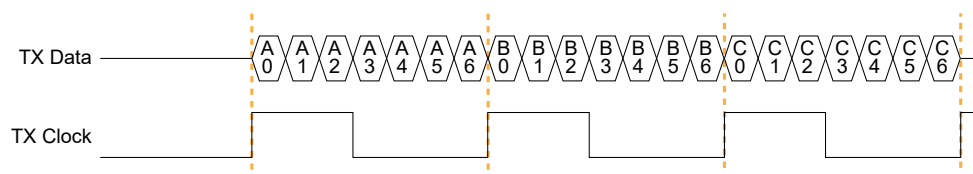
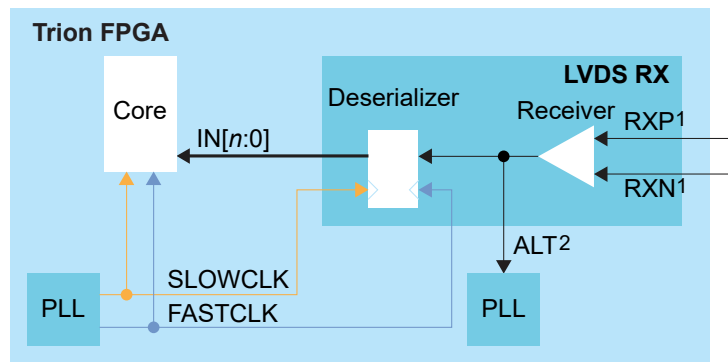

Table 20: LVDS TX Settings in Efinity® Interface Designer

Parameters	Choices	Notes
Mode	serial data output or reference clock output	<b>serial data output</b> —Simple output buffer or serialized output. <b>reference clock output</b> —Use the transmitter as a clock output. When choosing this mode, the <b>Serialization Width</b> you choose should match the serialization for the rest of the LVDS bus.
Parallel Clock Division	1, 2	<b>1</b> —The output clock from the LVDS TX lane is parallel clock frequency. <b>2</b> —The output clock from the TX lane is half of the parallel clock frequency.
Enable Serialization	On or off	When off, the serializer is bypassed and the LVDS buffer is used as a normal output.
Serialization Width	2, 3, 4, 5, 6, 7, or 8	Supports 8:1, 7:1, 6:1, 5:1, 4:1, 3:1, and 2:1.
Reduce VOD Swing	On or off	When true, enables reduced output swing (similar to slow slew rate).
Output Load	3, 5, 7 (default), or 10	Output load in pF. Use an output load of 7 pF or higher to achieve the maximum throughput of 800 Mbps.

## LVDS RX

Figure 15: LVDS RX Interface Block Diagram



1. There is a ~30k  $\Omega$  internal weak pull-up to VCCIO (3.3V).
2. Only available for an LVDS RX resource in bypass mode (deserialization width is 1).

Table 21: LVDS RX Signals (Interface to FPGA Fabric)

Signal	Direction	Notes
IN[n-1:0]	Output	Parallel input data where $n$ is the de-serialization factor. A width of 1 bypasses the deserializer.
ALT	Output	Alternative input, only available for an LVDS RX resource in bypass mode (deserialization width is 1; alternate connection type). Alternative connections are PLL_CLKIN and PLL_EXTFB.
FASTCLK	Input	Fast clock to de-serialize the data from the LVDS pads.
SLOWCLK	Input	Slow clock to latch the incoming data to the core.

Table 22: LVDS RX Pads

Pad	Direction	Description
RXP	Input	Differential P pad.
RXN	Input	Differential N pad.

The following waveform shows the relationship between the fast clock, slow clock, RX data coming in from the pad, and byte-aligned data to the core.

Figure 16: LVDS RX Timing Example Serialization Width of 8

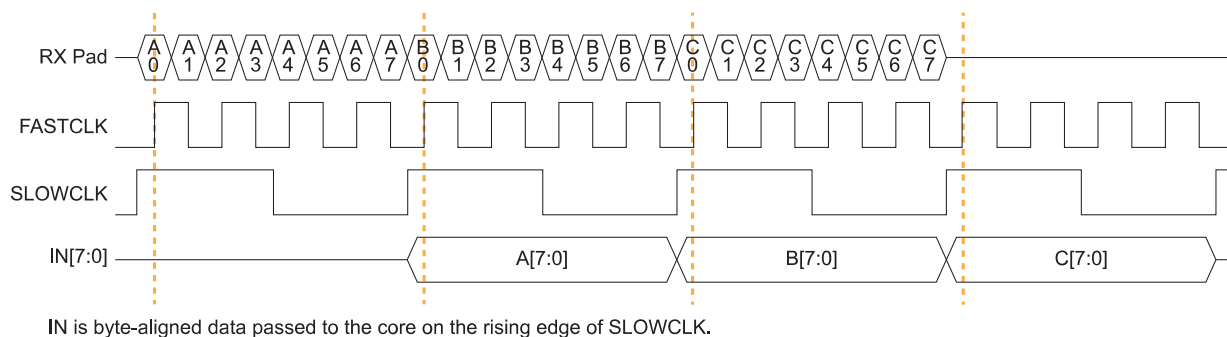

Table 23: LVDS RX Settings in Efinity® Interface Designer

Parameter	Choices	Notes
Connection Type	normal, pll_clkln, pll_extfb	<b>normal</b> —Regular RX function. <b>pll_clkln</b> —Use the PLL CLKIN alternate function of the LVDS RX resource. <b>pll_extfb</b> —Use the PLL external feedback alternate function of the LVDS RX resource.
Enable Deserialization	On or off	When off, the de-serializer is bypassed and the LVDS buffer is used as a normal input.
Deserialization Width	2, 3, 4, 5, 6, 7, or 8	Supports 8:1, 7:1, 6:1, 5:1, 4:1, 3:1, and 2:1.
Enable On-Die Termination	On or off	When on, enables an on-die 100-ohm resistor.

## MIPI

The MIPI CSI-2 interface is the most widely used camera interface for mobile.<sup>(8)</sup> You can use this interface to build single- or multi-camera designs for a variety of applications.

T35 FPGAs include two hardened MIPI D-PHY blocks (4 data lanes and 1 clock lane) with MIPI CSI-2 IP blocks. The MIPI RX and MIPI TX can operate independently with dedicated I/O banks.



**Note:** The MIPI D-PHY and CSI-2 controller are hard blocks; users cannot bypass the CSI-2 controller to access the D-PHY directly for non-CSI-2 applications.

The MIPI TX/RX interface supports the MIPI CSI-2 specification v1.3 and the MIPI D-PHY specification v1.1. It has the following features:

- Programmable data lane configuration supporting 1, 2, or 4 lanes
- High-speed mode supports up to 1.5 Gbps data rates per lane
- Operates in continuous and non-continuous clock modes
- 64 bit pixel interface for cameras
- Supports Ultra-Low Power State (ULPS)

Table 24: MIPI Supported Data Types

Supported Data Type	Format
RAW	RAW6, RAW7, RAW8, RAW10, RAW12, RAW14
YUV	YUV420 8-bit (legacy), YUV420 8-bit, YUV420 10-bit, YUV420 8-bit (CSPS), YUV420 10-bit (CSPS), YUV422 8-bit, YUV422 10-bit
RGB	RGB444, RGB555, RGB565, RGB666, RGB888
User Defined	8 bit format

<sup>(8)</sup> Source: MIPI Alliance <https://www.mipi.org/specifications/csi-2>

With more than one MIPI TX and RX blocks, Trion® FPGAs support a variety of video applications.

Figure 17: MIPI Example System

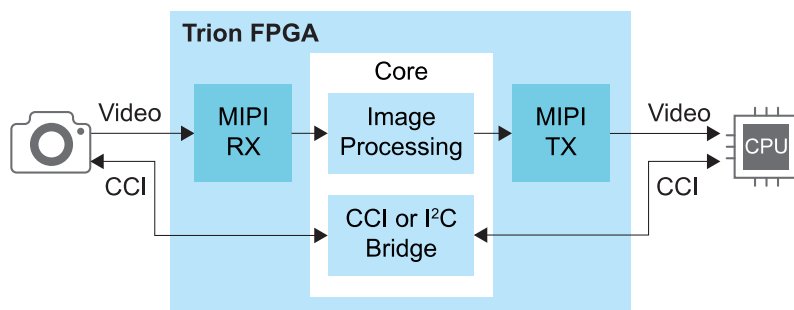

## MIPI TX

The MIPI TX is a transmitter interface that translates video data from the Trion® core into packetized data sent over the HSSI interface to the board. Five high-speed differential pin pairs (four data, one clock), each of which represent a lane, connect to the board. Control and video signals connect from the MIPI interface to the core.

Figure 18: MIPI TX x4 Block Diagram

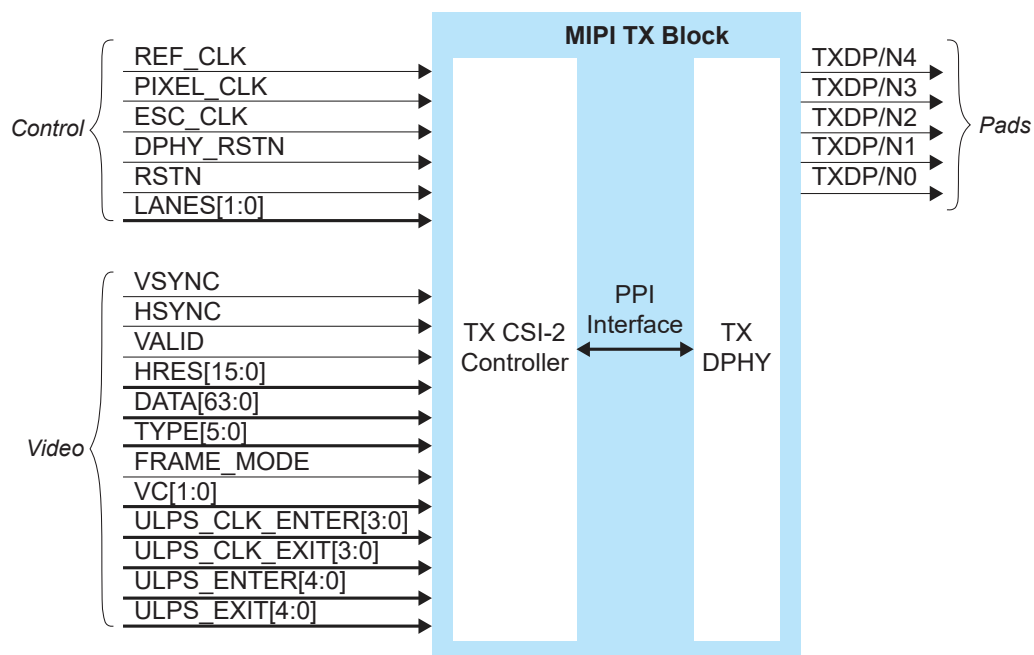

The control signals determine the clocking and how many transceiver lanes are used. All control signals are required except the two reset signals. The reset signals are optional, however, you must use both signals or neither.

The MIPI block requires an escape clock (`ESC_CLK`) for use when the MIPI interface is in escape (low-power) mode, which runs between 11 and 20 MHz.



**Note:** Efinix recommends that you set the escape clock frequency as close to 20 MHz as possible.

The video signals receive the video data from the core. The MIPI interface block encodes it and sends it out through the MIPI D-PHY lanes.

Figure 19: MIPI TX Interface Block Diagram

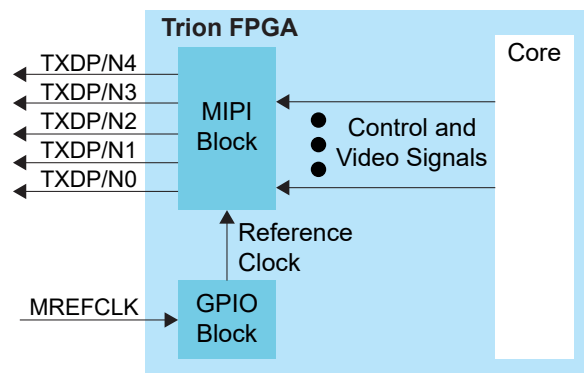

Table 25: MIPI TX Control Signals (Interface to FPGA Fabric)

Signal	Direction	Clock Domain	Description
REF_CLK	Input	N/A	Reference clock for the internal MIPI TX PLL used to generate the transmitted data. The FPGA has a dedicated GPIO resource (MREFCLK) that you must configure to provide the reference clock. All of the MIPI TX blocks share this resource. The frequency is set using Interface Designer configuration options.
PIXEL_CLK	Input	N/A	Clock used for transferring data from the core to the MIPI TX block. The frequency is based on the number of lanes and video format.
ESC_CLK	Input	N/A	Slow clock for escape mode (11 - 20 MHz).
DPHY_RSTN	Input	N/A	(Optional) Reset for the D-PHY logic, active low. Reset with the controller. See <b>MIPI Reset Timing</b> on page 54.
RSTN	Input	N/A	(Optional) Reset for the CSI-2 controller logic, active low. Typically, you reset the controller with the PHY (see <b>MIPI Reset Timing</b> on page 54). However, when dynamically changing the horizontal resolution, you only need to trigger RSTN (see <b>TX Requirements for Dynamically Changing the Horizontal Resolution</b> ).
LANES[1:0]	Input	PIXEL_CLK	Determines the number of lanes enabled. Can only be changed during reset. 00: lane 0 01: lanes 0 and 1 11: all lanes

Table 26: MIPI TX Video Signals (Interface to FPGA Fabric)

Signal	Direction	Clock Domain	Description
VSYNC	Input	PIXEL_CLK	Vertical sync.
HSYNC	Input	PIXEL_CLK	Horizontal sync.
VALID	Input	PIXEL_CLK	Valid signal.
HRES[15:0]	Input	PIXEL_CLK	Horizontal resolution. Can only be changed when VSYNC is low, and should be stable for at least one TX pixel clock cycle before VSYNC goes high.
DATA[63:0]	Input	PIXEL_CLK	Video data; the format depends on the data type. New data arrives on every pixel clock.
TYPE[5:0]	Input	PIXEL_CLK	Video data type. Can only be changed when HSYNC is low, and should be stable for at least one TX pixel clock cycle before HSYNC goes high.
FRAME_MODE	Input	PIXEL_CLK	Selects frame format. <sup>(9)</sup> 0: general frame 1: accurate frame Can only be changed during reset.
VC[1:0]	Input	PIXEL_CLK	Virtual channel (VC). Can only be changed when VSYNC is low, and should be stable at least one TX pixel clock cycle before VSYNC goes high.
ULPS_CLK_ENTER	Input	PIXEL_CLK	Place the clock lane into ULPS mode. Should not be active at the same time as ULPS_CLK_EXIT. Each high pulse should be at least 5 $\mu$ s.
ULPS_CLK_EXIT	Input	PIXEL_CLK	Remove clock lane from ULPS mode. Should not be active at the same time as ULPS_CLK_ENTER. Each high pulse should be at least 5 $\mu$ s.
ULPS_ENTER[3:0]	Input	PIXEL_CLK	Place the data lane into ULPS mode. Should not be active at the same time as ULPS_EXIT[3:0]. Each high pulse should be at least 5 $\mu$ s.
ULPS_EXIT[3:0]	Input	PIXEL_CLK	Remove the data lane from ULPS mode. Should not be active at the same time as ULPS_ENTER[3:0]. Each high pulse should be at least 5 $\mu$ s.

Table 27: MIPI TX Pads

Pad	Direction	Description
TXDP[4:0]	Output	MIPI transceiver P pads.
TXDN[4:0]	Output	MIPI transceiver N pads.

<sup>(9)</sup> Refer to the MIPI Camera Serial Interface 2 (MIPI CSI-2) for more information about frame formats.

Table 28: MIPI TX Settings in Efinity® Interface Designer

Tab	Parameter	Choices	Notes
Base	PHY Frequency (MHz)	80.00 - 1500.00	Choose one of the possible PHY frequency values.
	Frequency (reference clock)	6, 12, 19.2, 25, 26, 27, 38.4, or 52 MHz	Reference clock frequency.
	Enable Continuous PHY Clocking	On or Off	Turns continuous clock mode on or off.
Control	Escape Clock Pin Name	User defined	
	Invert Escape Clock	On or Off	
	Pixel Clock Pin Name	User defined	
	Invert Pixel Clock	On or Off	
Lane Mapping	TXD0, TXD1, TXD2, TXD3, TXD4	clk, data0, data1, data2, or data3	Map the physical lane to a clock or data lane.
<b>Clock Timer</b>			
Timing	T <sub>CLK-POST</sub> T <sub>CLK-TRAIL</sub> T <sub>CLK-PREPARE</sub> T <sub>CLK-ZERO</sub>	Varies depending on the PHY frequency	Changes the MIPI transmitter timing parameters per the DPHY specification. Refer to <b>D-PHY Timing Parameters</b> on page 34.
	Escape Clock Frequency (MHz)	User defined	Specify a number between 11 and 20 MHz.
	T <sub>CLK-PRE</sub>	Varies depending on the escape clock frequency	Changes the MIPI transmitter timing parameters per the DPHY specification. Refer to <b>D-PHY Timing Parameters</b> on page 34.
	<b>Data Timer</b>		
	T <sub>HS-PREPARE</sub> T <sub>HS-ZERO</sub> T <sub>HS-PTRAIL</sub>	Varies depending on the PHY frequency	Changes the MIPI transmitter timing parameters per the DPHY specification. Refer to <b>D-PHY Timing Parameters</b> on page 34.

## MIPI TX Video Data TYPE[5:0] Settings

The video data type can only be changed when HSYNC is low.

Table 29: MIPI TX TYPE[5:0]

TYPE[5:0]	Data Type	Pixel Data Bits per Pixel Clock	Pixels per Clock	Bits per Pixel	Maximum Data Pixels per Line
0x20	RGB444	48	4	12	2,880
0x21	RGB555	60	4	15	2,880
0x22	RGB565	64	4	16	2,880
0x23	RGB666	54	3	18	2,556
0x24	RGB888	48	2	24	1,920
0x28	RAW6	60	10	6	7,680
0x29	RAW7	56	8	7	6,576
0x2A	RAW8	64	8	8	5,760
0x2B	RAW10	60	6	10	4,608
0x2C	RAW12	60	5	12	3,840
0x2D	RAW14	56	4	14	3,288
0x18	YUV420 8 bit	Odd line: 64 Even line: 64	Odd line: 8 Even line: 4	Odd line: 8 Even line: 8, 24	2,880
0x19	YUV420 10 bit	Odd line: 60 Even line: 40	Odd line: 6 Even line: 2	Odd line: 10 Even line: 10, 30	2,304
0x1A	Legacy YUV420 8 bit	48	4	8, 16	3,840
0x1C	YUV420 8 bit (CSPS)	Odd line: 64 Even line: 64	Odd line: 8 Even line: 4	Odd line: 8 Even line: 8, 24	2,880
0x1D	YUV420 10 bit (CSPS)	Odd line: 60 Even line: 40	Odd line: 6 Even line: 2	Odd line: 10 Even line: 10, 30	2,304
0x1E	YUV422 8 bit	64	4	8, 24	2,880
0x1F	YUV422 10 bit	40	2	10, 30	2,304
0x30 - 37	User defined 8 bit	64	8	8	5,760

## MIPI RX

The MIPI RX is a receiver interface that translates HSSI signals from the board to video data in the Trion® core. Five high-speed differential pin pairs (one clock, four data), each of which represent a lane, connect to the board. Control, video, and status signals connect from the MIPI interface to the core.

Figure 20: MIPI RX x4 Block Diagram

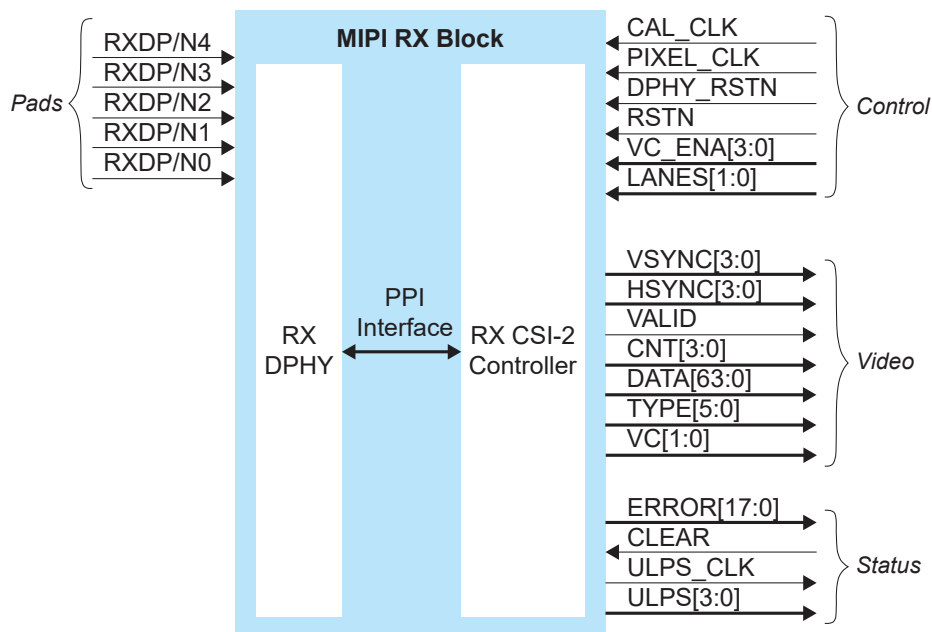

The control signals determine the clocking, how many transceiver lanes are used, and how many virtual channels are enabled. All control signals are required except the two reset signals. The reset signals are optional, however, you must use both signals or neither.

The video signals send the decoded video data to the core. All video signals must fully support the MIPI standard.

The status signals provide optional status and error information about the MIPI RX interface operation.

Figure 21: MIPI RX Interface Block Diagram

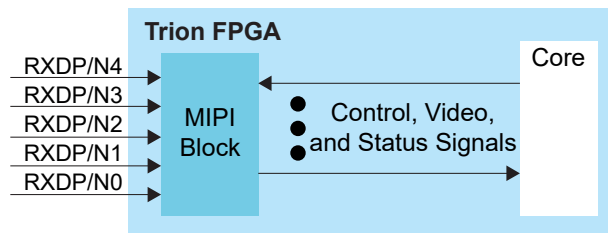

**Table 30: MIPI RX Control Signals (Interface to FPGA Fabric)**

Signal	Direction	Clock Domain	Notes
CAL_CLK	Input	N/A	Used for D-PHY calibration; must be between 80 and 120 MHz.
PIXEL_CLK	Input	N/A	Clock used for transferring data to the core from the MIPI RX block. The frequency based on the number of lanes and video format.
DPHY_RSTN	Input	N/A	(Optional) Reset for the D-PHY logic, active low. Must be used if RSTN is used. See <a href="#">MIPI Reset Timing</a> on page 54.
RSTN	Input	N/A	(Optional) Reset for the CSI-2 controller logic, active low. Must be used if DPHY_RSTN is used. See <a href="#">MIPI Reset Timing</a> on page 54.
VC_ENA[3:0]	Input	PIXEL_CLK	Enables different VC channels by setting their index high.
LANES[1:0]	Input	PIXEL_CLK	Determines the number of lanes enabled: 00: lane 0 01: lanes 0 and 1 11: all lanes Can only be set during reset.

**Table 31: MIPI RX Video Signals (Interface to FPGA Fabric)**

Signal	Direction	Clock Domain	Notes
VSYNC[3:0]	Output	PIXEL_CLK	Vsync bus. High if vsync is active for this VC.
HSYNC[3:0]	Output	PIXEL_CLK	Hsync bus. High if hsync is active for this VC
VALID	Output	PIXEL_CLK	Valid signal.
CNT[3:0]	Output	PIXEL_CLK	Number of valid pixels contained in the pixel data.
DATA[63:0]	Output	PIXEL_CLK	Video data, format depends on data type. New data every pixel clock.
TYPE[5:0]	Output	PIXEL_CLK	Video data type.
VC[1:0]	Output	PIXEL_CLK	Virtual channel (VC).

**Table 32: MIPI RX Status Signals (Interface to FPGA Fabric)**

Signal	Direction	Signal Interface	Clock Domain	Notes
ERROR[17:0]	Output	IN	PIXEL_CLK	Error bus register. Refer to <a href="#">Table 33: MIPI RX Error Signals (ERROR[17:0])</a> on page 31 for details.
CLEAR	Input	OUT	PIXEL_CLK	Reset the error registers.
ULPS_CLK	Output	IN	PIXEL_CLK	High when the clock lane is in the Ultra-Low-Power State (ULPS).
ULPS[3:0]	Output	IN	PIXEL_CLK	High when the lane is in the ULPS mode.

Table 33: MIPI RX Error Signals (ERROR[17:0])

Bit	Name	Description
0	ERR_ESC	Escape Entry Error. Asserted when an unrecognized escape entry command is received.
1	CRC_ERROR_VC0	CRC Error VC0. Set to 1 when a checksum error occurs.
2	CRC_ERROR_VC1	CRC Error VC1. Set to 1 when a checksum error occurs.
3	CRC_ERROR_VC2	CRC Error VC2. Set to 1 when a checksum error occurs.
4	CRC_ERROR_VC3	CRC Error VC3. Set to 1 when a checksum error occurs.
5	HS_RX_TIMEOUT_ERR	HS RX Timeout Error. The protocol should time out when no EoT is received within a certain period in HS RX mode.
6	ECC_1BIT_ERROR	ECC Single Bit Error. Set to 1 when there is a single bit error.
7	ECC_2BIT_ERROR	ECC 2 Bit Error. Set to 1 if there is a 2 bit error in the packet.
8	ECCBIT_ERROR	ECC Error. Asserted when an error exists in the ECC.
9	ECC_NO_ERROR	ECC No Error. Asserted when an ECC is computed with a result zero. This bit is high when the receiver is receiving data correctly.
10	FRAME_SYNC_ERROR	Frame Sync Error. Asserted when a frame end is not paired with a frame start on the same virtual channel.
11	INVLD_PKT_LEN	Invalid Packet Length. Set to 1 if there is an invalid packet length.
12	INVLD_VC	Invalid VC ID. Set to 1 if there is an invalid CSI VC ID.
13	INVALID_DATA_TYPE	Invalid Data Type. Set to 1 if the received data is invalid.
14	ERR_FRAME	Error In Frame. Asserted when VSYNC END received when CRC error is present in the data packet.
15	CONTROL_ERR	Control Error. Asserted when an incorrect line state sequence is detected.
16	SOT_ERR	Start-of-Transmission (SoT) Error. Corrupted high-speed SoT leader sequence while proper synchronization can still be achieved.
17	SOT_SYNC_ERR	SoT Synchronization Error. Corrupted high-speed SoT leader sequence while proper synchronization cannot be expected.



**Note:** If error report is all logic low, there is an EOT or a contention error. Check the physical connection of MIPI lanes or adjust the EXIT and TRAIL parameters according to the MIPI Utility.

Table 34: MIPI RX Pads

Pad	Direction	Description
RXDP[4:0]	Input	MIPI transceiver P pads.
RXDN[4:0]	Input	MIPI transceiver N pads.

Table 35: MIPI RX Settings in Efinity® Interface Designer

Tab	Parameter	Choices	Notes
Control	DPHY Calibration Clock Pin Name	User defined	
	Invert DPHY Calibration Clock	On or Off	
	Pixel Clock Pin Name	User defined	
	Invert Pixel Clock	On or Off	
Status	Enable Status	On or Off	Indicate whether you want to use the status pins.
Lane Mapping	RXD0, RXD1, RXD2, RXD3, RXD4	clk, data0, data1, data2, or data3	Map the physical lane to a clock or data lane.
	Swap P&N Pin	On or Off	Reverse the P and N pins for the physical lane.
Timing	Calibration Clock Freq (MHz)	User defined	Specify a number between 80 and 120 MHz.
	Clock Timer (T <sub>CLK-SETTLE</sub> )	40 - 2,590 ns	Changes the MIPI receiver timing parameters per the DPHY specification. Refer to <b>D-PHY Timing Parameters</b> on page 34.
	Data Timer (T <sub>HS-SETTLE</sub> )	40 - 2,590 ns	Changes the MIPI receiver timing parameters per the DPHY specification. Refer to <b>D-PHY Timing Parameters</b> on page 34.

## MIPI RX Video Data TYPE[5:0] Settings

The video data type can only be changed when HSYNC is low.

Table 36: MIPI RX TYPE[5:0]

TYPE[5:0]	Data Type	Pixel Data Bits per Pixel Clock	Pixels per Clock	Bits per Pixel	Maximum Data Pixels per Line
0x20	RGB444	48	4	12	2,880
0x21	RGB555	60	4	15	2,880
0x22	RGB565	64	4	16	2,880
0x23	RGB666	54	3	18	2,556
0x24	RGB888	48	2	24	1,920
0x28	RAW6	48	8	6	7,680
0x29	RAW7	56	8	7	6,576
0x2A	RAW8	64	8	8	5,760
0x2B	RAW10	40	4	10	4,608
0x2C	RAW12	48	4	12	3,840
0x2D	RAW14	56	4	14	3,288
0x18	YUV420 8 bit	Odd line: 64 Even line: 64	Odd line: 8 Even line: 4	Odd line: 8 Even line: 8, 24	2,880
0x19	YUV420 10 bit	Odd line: 40 Even line: 40	Odd line: 4 Even line: 2	Odd line: 10 Even line: 10, 30	2,304
0x1A	Legacy YUV420 8 bit	48	4	8, 16	3,840
0x1C	YUV420 8 bit (CSPS)	Odd line: 64 Even line: 64	Odd line: 8 Even line: 4	Odd line: 8 Even line: 8, 24	2,880
0x1D	YUV420 10 bit (CSPS)	Odd line: 40 Even line: 40	Odd line: 4 Even line: 2	Odd line: 10 Even line: 10, 30	2,304
0x1E	YUV422 8 bit	64	4	8, 24	2,880
0x1F	YUV422 10 bit	40	2	10, 30	2,304
0x30 - 37	User defined 8 bit	64	8	8	5,760

## D-PHY Timing Parameters

During CSI-2 data transmission, the MIPI D-PHY alternates between low power mode and high-speed mode. The D-PHY specification defines timing parameters to facilitate the correct hand-shaking between the MIPI TX and MIPI RX during mode transitions.

You set the timing parameters to correspond to the specifications of your hardware in the Efinity® Interface Designer.

- *RX parameters*— $T_{CLK-SETTLE}$ ,  $T_{HS-SETTLE}$  (see [Table 30: MIPI RX Control Signals \(Interface to FPGA Fabric\)](#) on page 30)
- *TX parameters*— $T_{CLK-POST}$ ,  $T_{CLK-TRAIL}$ ,  $T_{CLK-PREPARE}$ ,  $T_{CLK-ZERO}$ ,  $T_{CLK-PRE}$ ,  $T_{HS-PREPARE}$ ,  $T_{HS-ZERO}$ ,  $T_{HS-TRAIL}$  (see [Table 28: MIPI TX Settings in Efinity Interface Designer](#) on page 27)

Figure 22: High-Speed Data Transmission in Bursts Waveform

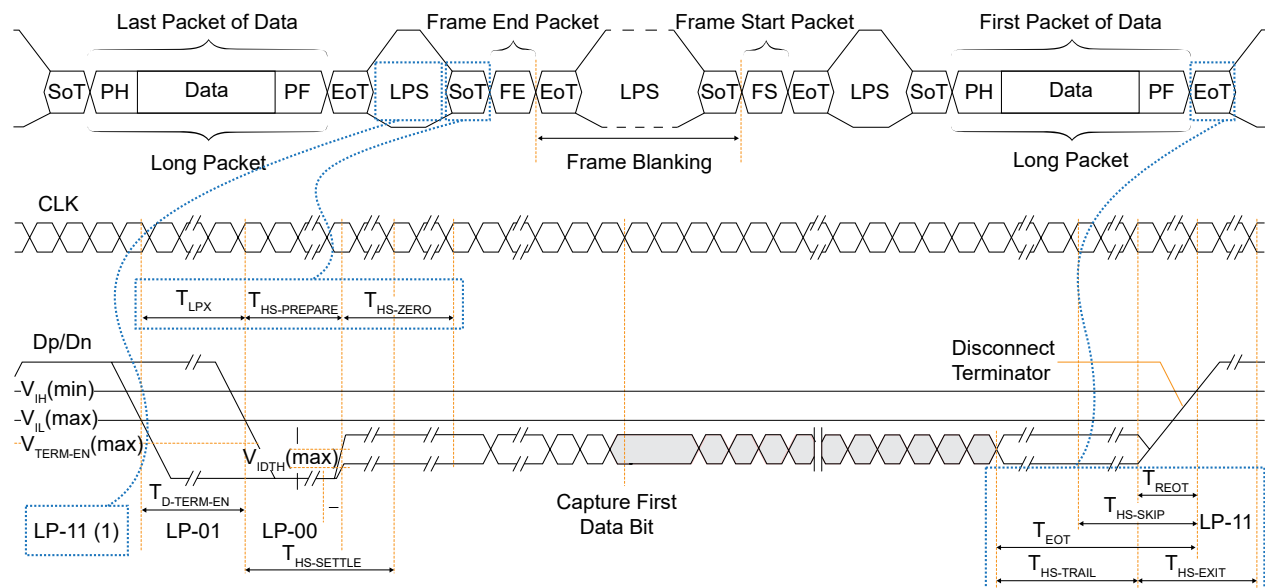

Note:

1. To enter high-speed mode, the D-PHY goes through states LP-11, LP-01, and LP-00. The D-PHY generates LP-11 to exit high-speed mode.

Figure 23: Switching the Clock Lane between Clock Transmission and Low Power Mode Waveform

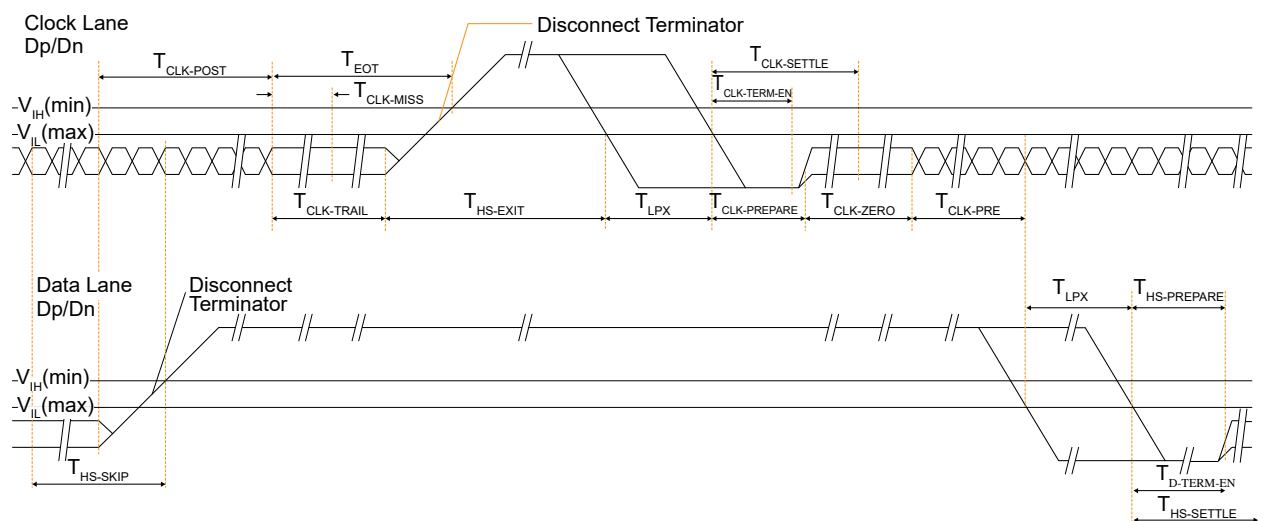

Table 37: D-PHY Timing Specifications

Parameter	Description	Min	Typ	Max	Unit
$T_{CLK-POST}$	Time that the transmitter continues to send HS clock after the last associated Data Lane has transitioned to LP Mode. Interval is defined as the period from the end of $T_{HS-TRAIL}$ to the beginning of $T_{CLK-TRAIL}$ .	$60\text{ ns} + 52*UI$	-	-	ns
$T_{CLK-PRE}$	Time that the HS clock shall be driven by the transmitter prior to any associated Data Lane beginning the transition from LP to HS mode.	8	-	-	UI
$T_{CLK-PREPARE}$	Time that the transmitter drives the Clock Lane LP-00 Line state immediately before the HS-0 Line state starting the HS transmission.	38	-	95	ns
$T_{CLK-SETTLE}$	Time interval during which the HS receiver should ignore any Clock Lane HS transitions, starting from the beginning of $T_{CLK-PREPARE}$ .	95	-	300	ns
$T_{CLK-TRAIL}$	Time that the transmitter drives the HS-0 state after the last payload clock bit of a HS transmission burst.	60	-	-	ns
$T_{CLK-PREPARE} + T_{CLK-ZERO}$	$T_{CLK-PREPARE}$ + time that the transmitter drives the HS-0 state prior to starting the Clock.	300	-	-	ns
$T_{HS-PREPARE}$	Time that the transmitter drives the Data Lane LP-00 Line state immediately before the HS-0 Line state starting the HS transmission	$40\text{ ns} + 4*UI$	-	$85\text{ ns} + 6*UI$	ns
$T_{HS-SETTLE}$	Time interval during which the HS receiver shall ignore any Data Lane HS transitions, starting from the beginning of $T_{HS-PREPARE}$ . The HS receiver shall ignore any Data Lane transitions before the minimum value, and the HS receiver shall respond to any Data Lane transitions after the maximum value.	$85\text{ ns} + 6*UI$	-	$145\text{ ns} + 10*UI$	ns
$T_{HS-TRAIL}$	Time that the transmitter drives the flipped differential state after last payload data bit of a HS transmission burst	$\max(n*8*UI, 60\text{ ns} + n*4*UI)$	-	-	ns
$T_{LPX}$	Transmitted length of any Low-Power state period	50	-	-	ns
$T_{HS-PREPARE} + T_{HS-ZERO}$	$T_{HS-PREPARE}$ + time that the transmitter drives the HS-0 state prior to transmitting the Sync sequence.	$145\text{ ns} + 10*UI$	-	-	ns

## DDR DRAM

Some T35 FPGAs have a x16 DDR PHY interface supporting DDR3, DDR3L, LPDDR3, and LPDDR2 as well as a memory controller hard IP block. The DDR PHY supports data rates up to 1066 Mbps per lane. The memory controller provides two 128 bit AXI buses to communicate with the FPGA core.



**Note:** The DDR PHY and controller are hard blocks; you cannot bypass the DDR DRAM memory controller to access the PHY directly for non-DDR memory controller applications.

Figure 24: DDR DRAM Block Diagram

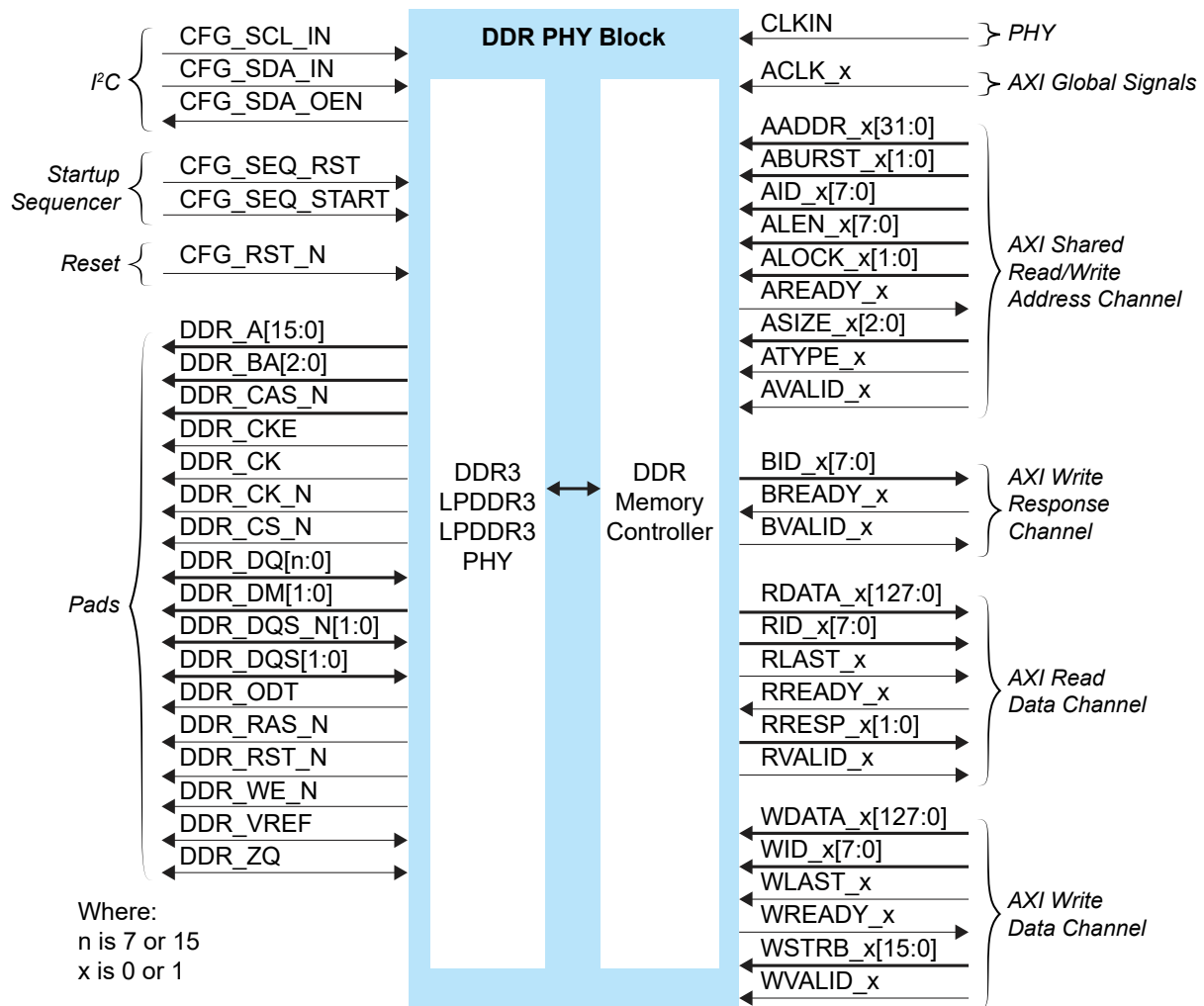

The DDR DRAM block supports an I<sup>2</sup>C calibration bus that can read/write the DDR configuration registers. You can use this bus to fine tune the DDR PHY for high performance.

Figure 25: DDR DRAM Interface Block Diagram

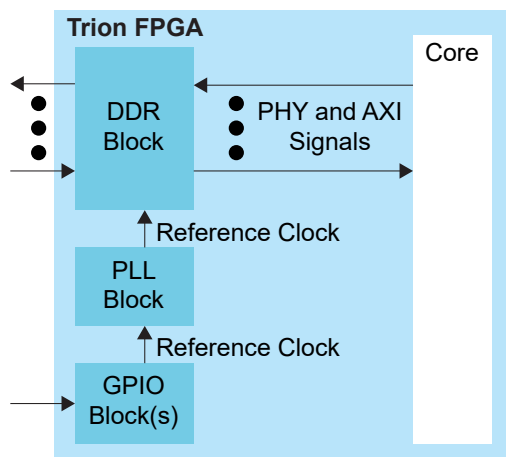

**Note:** The PLL reference clock must be driven by I/O pads. The Efinity® software issues a warning if you do not connect the reference clock to an I/O pad. (Using the clock tree may induce additional jitter and degrade the DDR performance.) Refer to **PLL** on page 15 for more information about the PLL block.

Table 38: DDR DRAM Performance

DDR DRAM Interface	Voltage (V)	Maximum Data Rate (Mbps) per Lane
DDR3	1.5	1066
DDR3L	1.35	1066
LPDDR3	1.2	1066
LPDDR2	1.2	1066

Table 39: PHY Signals (Interface to FPGA Fabric)

Signal	Direction	Clock Domain	Description
CLKIN	Input	N/A	High-speed clock to drive the DDR PHY. A PLL must generate this clock. The clock runs at half of the PHY data rate (for example, 800 Mbps requires a 400 MHz clock). The DDR DRAM block uses the PLL_BR0 CLKOUT0 resource as the PHY clock.

Table 40: AXI Global Signals (Interface to FPGA Fabric)

Signal	Direction	Clock Domain	Description
ACLK_0, ACLK_1	Input	N/A	AXI clock inputs.

**Table 41: AXI Shared Read/Write Signals (Interface to FPGA Fabric)**

Signal x is 0 or 1	Direction	Clock Domain	Description
AADDR_x[31:0]	Input	ACLK_x	Address. ATYPE defines whether it is a read or write address. It gives the address of the first transfer in a burst transaction.
ABURST_x[1:0]	Input	ACLK_x	Burst type. The burst type and the size determine how the address for each transfer within the burst is calculated.
AID_x[7:0]	Input	ACLK_x	Address ID. This signal identifies the group of address signals. Depends on ATYPE, the ID can be for a read or write address group.
ALEN_x[7:0]	Input	ACLK_x	Burst length. This signal indicates the number of transfers in a burst.
ALOCK_x[1:0]	Input	ACLK_x	Lock type. This signal provides additional information about the atomic characteristics of the transfer.
AREADY_x	Output	ACLK_x	Address ready. This signal indicates that the slave is ready to accept an address and associated control signals.
ASIZE_x[2:0]	Input	ACLK_x	Burst size. This signal indicates the size of each transfer in the burst.
ATYPE_x	Input	ACLK_x	This signal distinguishes whether it is a read or write operation. 0 = read and 1 = write.
AVALID_x	Input	ACLK_x	Address valid. This signal indicates that the channel is signaling valid address and control information.

**Table 42: AXI Write Response Channel Signals (Interface to FPGA Fabric)**

Signal x is 0 or 1	Direction	Clock Domain	Description
BID_x[7:0]	Output	ACLK_x	Response ID tag. This signal is the ID tag of the write response.
BREADY_x	Input	ACLK_x	Response ready. This signal indicates that the master can accept a write response.
BVALID_x	Output	ACLK_x	Write response valid. This signal indicates that the channel is signaling a valid write response.

**Table 43: AXI Read Data Channel Signals (Interface to FPGA Fabric)**

Signal x is 0 or 1	Direction	Clock Domain	Description
RDATA_x[127:0]	Output	ACLK_x	Read data.
RDATA_0[255:0]	Output	ACLK_0	AXI target 0 read data.
RDATA_1[127:0]	Output	ACLK_1	AXI target 1 read data.
RID_x[7:0]	Output	ACLK_x	Read ID tag. This signal is the identification tag for the read data group of signals generated by the slave.
RLAST_x	Output	ACLK_x	Read last. This signal indicates the last transfer in a read burst.
RREADY_x	Input	ACLK_x	Read ready. This signal indicates that the master can accept the read data and response information.
RRESP_x[1:0]	Output	ACLK_x	Read response. This signal indicates the status of the read transfer.
RVALID_x	Output	ACLK_x	Read valid. This signal indicates that the channel is signaling the required read data.

**Table 44: AXI Write Data Channel Signals (Interface to FPGA Fabric)**

Signal x is 0 or 1	Direction	Clock Domain	Description
WDATA_x[127:0]	Input	ACLK_x	Write data.
WDATA_0[255:0]	Input	ACLK_0	AXI target 0 write data.
WDATA_1[127:0]	Input	ACLK_1	AXI target 1 write data.
WID_x[7:0]	Input	ACLK_x	Write ID tag. This signal is the ID tag of the write data transfer.
WLAST_x	Input	ACLK_x	Write last. This signal indicates the last transfer in a write burst.
WREADY_x	Output	ACLK_x	Write ready. This signal indicates that the slave can accept the write data.
WSTRB_x[15:0]	Input	ACLK_x	Write strobes. This signal indicates which byte lanes hold valid data. There is one write strobe bit for each eight bits of the write data bus.
WSTRB_0[31:0] WSTRB_1[15:0]	Input	ACLK_x	Write strobes. This signal indicates which byte lanes hold valid data. There is one write strobe bit for each eight bits of the write data bus.
WVALID_x	Input	ACLK_x	Write valid. This signal indicates that valid write data and strobes are available.

**Table 45: DDR DRAM I<sup>2</sup>C Interface Signals**

Signal	Direction	Description
CFG_SCL_IN	Input	Clock input.
CFG_SDA_IN	Input	Data input.
CFG_SDA_OEN	Output	SDA output enable.

**Table 46: DDR DRAM Startup Sequencer Signals**

Signal	Direction	Description
CFG_SEQ_RST	Input	Active-high DDR configuration controller reset.
CFG_SEQ_START	Input	Start the DDR configuration controller.

**Table 47: DDR DRAM Reset Signal**

Signal	Direction	Description
CFG_RST_N	Input	Active-low master DDR DRAM reset. After you de-assert RST_N, you need to reconfigure and initialize before performing memory operations.

Table 48: DDR DRAM Pads

Signal	Direction	Description
DDR_A[15:0]	Output	Address signals to the memories.
DDR_BA[2:0]	Output	Bank signals to/from the memories.
DDR_CAS_N	Output	Active-low column address strobe signal to the memories.
DDR_CKE	Output	Active-high clock enable signals to the memories.
DDR_CK	Output	Active-high clock signals to/from the memories. The clock to the memories and to the memory controller must be the same clock frequency and phase.
DDR_CK_N	Output	Active-low clock signals to/from the memories. The clock to the memories and to the memory controller must be the same clock frequency and phase.
DDR_CS_N	Output	Active-low chip select signals to the memories.
DDR_DQ[n:0]	Bidirectional	Data bus to/from the memories. For writes, the pad drives these signals. For reads, the memory drives these signals. These signals are connected to the DQ inputs on the memories. $n$ is 7 or 15 depending on the DQ Width Configuration setting.
DDR_DM[n]	Output	Active-high data-mask signals to the memories. $n$ is 0 or 1:0 depending on the DQ width.
DDR_DQS_N[n:0]	Bidirectional	Differential data strobes to/from the memories. For writes, the pad drives these signals. For reads, the memory drives these signals. These signals are connected to the DQS inputs on the memories. $n$ is 0 or 1:0 depending on the DQ width.
DDR_DQS[n:0]	Bidirectional	
DDR_ODT	Output	ODT signal to the memories.
DDR_RAS_N	Output	Active-low row address strobe signal to the memories.
DDR_RST_N	Output	Active-low reset signals to the memories.
DDR_WE_N	Output	Active-low write enable strobe signal to the memories.
DDR_VREF	Bidirectional	Reference voltage.
DDR_ZQ	Bidirectional	ZQ calibration pin.

## DDR Interface Designer Settings

The following tables describe the settings for the DDR block in the Interface Designer.

Table 49: Base Tab

Parameter	Choices	Notes
DDR Resource	None, DDR_0	Only one resource available.
Instance Name	User defined	Indicate the DDR instance name. This name is the prefix for all DDR signals.
Memory Type	DDR3, LPDDR2, LPDDR3	Choose the memory type you want to use.

Table 50: Configuration Tab

Parameter	Choices	Notes
Select Preset		The <b>Select Preset</b> button opens a list of popular DDR memory configurations. Choose a preset to populate the configuration choices. If you do not want to use a preset, you can specify the memory configuration manually.
DQ Width	x8, x16	DQ bus width.
Type	DDR3, LPDDR2, LPDDR3	Memory type.
<b>DDR3</b>		
Speed Grade	1066E, 1066F, 1066G, 800D, 800E	Memory speed.
Width	x8, x16	Memory width.
Density	1G, 2G, 4G, 8G	Memory density in bits.
<b>LPDDR2</b>		
Speed Grade	400, 533, 667, 800, 1066	Memory speed.
Width	x16	Memory width.
Density	256M, 512M, 1G, 2G, 4G	Memory density in bits.
<b>LPDDR3</b>		
Speed Grade	800, 1066	Memory speed.
Width	x16	Memory width.
Density	4G, 8G	Memory density in bits.

Table 51: Advanced Options Tab - FPGA Setting Subtab

Parameter	Choices	Notes
FPGA Input Termination	Varies depending on the memory type	Specify the termination value for the FPGA input/output pins.
FPGA Output Termination		

Table 52: Advanced Options Tab - Memory Mode Register Settings Subtab

Parameter	Choices	Notes
<b>DDR3</b>		
Burst Length	8	Specify the burst length (only 8 is supported).
DLL Precharge Power Down	On, Off	Specify whether the DLL in the memory device is off or on during precharge power-down.
Memory Auto Self-Refresh	Auto, Manual	Turn on or off auto-self refresh feature in memory device.
Memory CAS Latency (CL)	5 - 14	Specify the number of clock cycle between read command and the availability of output data at the memory device.
Memory Write CAS Latency (CWL)	5 - 12	Specify the number of clock cycle from the releasing of the internal write to the latching of the first data in at the memory device.
Memory Dynamic ODT (Rtt_WR)	Off, RZQ/2, RZQ/4	Specify the mode of dynamic ODT feature of memory device.

Parameter	Choices	Notes
Memory Input Termination (Rtt_nom)	Off, RZQ/2, RZQ/4, RZQ/6, RZQ/8, RZQ/12	Specify the input termination value of the memory device.
Memory Output Termination	RZQ/6, RZQ/7	Specify the output termination value of the memory device.
Read Burst Type	Interleaved, Sequential	Specify whether accesses within a give burst are in sequential or interleaved order.
Sef-Refresh Temperature	Extended, Normal	Specify whether the self refresh temperature is normal or extended mode.
<b>LPDDR2</b>		
Burst Length	8	Specify the burst length (only 8 is supported).
Output Drive Strength	34.3, 40, 48, 60, 80, 120	Specify the output termination value of memory device.
Read Burst Type	Interleaved, Sequential	Specify whether accesses within a given burst are in sequential or interleaved order.
Read/Write Latency	RL=3/WL=1, RL=4/WL=2 RL=5/WL=2, RL=6/WL=3 RL=7/WL=4, RL=8/WL=4	Specify the read/write latency of the memory device.
<b>LPDDR3</b>		
DQ ODT	Disable, RZQ1, RZQ2, RZQ4	Specify the input termination value of memory device.
Output Drive Strength	34.3 34.3 pull-down/40 pull up 34.3 pull-down/48 pull up 40 40 pull down/48 pull up 48	Specify the output termination value of memory device.
Read/Write Latency	RL=3/WL=1, RL=6/WL=3 RL=8/WL=4, RL=9/WL=5	Specify the read/write latency of the memory device.

**Table 53: Advanced Options Tab - Memory Timing Settings Subtab**

Parameter	Choices	Notes
tFAW, Four Bank Active Window (ns)	User defined	Enter the timing parameters from the memory device's data sheet.
tRAS, Active to Precharge Command Period (ns)		
tRC, Active to Actrive or REF Command Period (ns)		
tRCD, Active to Read or Write Delay (ns)		
tREFI, Average Periodic Refresh Interval (ns)		
tRFC, Refresh to Active or Refresh to Refresh Delay (ns)		
tRP, Precharge Command Period (ns)		
tRRD, Active to Active Command Period (ns)		
tRTP, Internal Read to Precharge Delay (ns)		
tWTR, Internal Write to Read Command Delay (ns)		

**Table 54: Advanced Options Tab - Controller Settings Subtab**

Parameter	Choices	Notes
Controller to Memory Address Mapping	BANK-ROW-COL ROW-BANK-COL ROW-COL_HIGH-BANK-COL_LOW	Specify the mapping between the address of AXI interface and column, row, and bank address of memory device.
Enable Auto Power Down	Active, Off, Pre-Charge	Specify whether to allow automatic entry into power-down mode (pre-charge or active) after a specific amount of idle time.
Enable Self Refresh Controls	No, Yes	Specify whether to enable automatic entry into self-refresh mode after specific amount of idle period.

**Table 55: Advanced Options Tab - Gate Delay Tuning Settings Subtab**

Parameter	Choices	Notes
Enable Gate Delay Override	On or off	Turning this option on allows you to fine-tune the gate-delay values. This is an expert only setting.
Gate Coarse Delay Tuning	0 - 5	
Gate Fine Delay Tuning	0 - 255	

**Table 56: Control Tab**

Option	Notes
Disable Control	When selected, this option disables calibration and user reset.
Enable Calibration	Turn on to enable optional PHY calibration pins (master reset, SCL, and SDA pins). Efinix recommends that you use the default pin names. The names are prefixed with the instance name you specified in the Base tab.
User Reset	Turn on to enable optional reset pins (master reset and sequencer start/reset). Efinix recommends that you use the default pin names. The names are prefixed with the instance name you specified in the Base tab.

**Table 57: AXI 0 and AXI 1 Tabs**

Parameter	Choices	Notes
Enable Target 0	On or off	Turn on to enable the AXI 0 interface.
Enable Target 1	On or off	Turn on to enable the AXI 1 interface.
AXI Clock Input Pin name	User defined	Specify the name of the AXI input clock pin.
Invert AXI Clock Input	On or off	Turn on to invert the AXI clock.
Shared Read/Write Address Channel tab Write Response Channel tab Read Data Channel tab Write Data Channel tab	User defined	This tab defines the AXI signal names. Efinix recommends that you use the default names. The signals are prefixed with the instance name you specified in the Base tab.

# Power Up Sequence

Efnix® recommends the following power up sequence when powering Trion® FPGAs:

1. Power up VCC and VCCA\_XX first.
2. When VCC and VCCA\_XX are stable, power up all VCCIO pins. There is no specific timing delay between the VCCIO pins.
3. Apply power to VCC12A\_MIPI\_TX, VCC12A\_MIPI\_RX, and VCC25A\_MIPI at least  $t_{\text{MIPI\_POWER}}$  after VCC is stable.
4. After all power supplies are stable, hold CRESET\_N low for a duration of  $t_{\text{CRESET\_N}}$  before asserting CRESET\_N from low to high to trigger active SPI programming (the FPGA loads the configuration data from an external flash device).

When you are not using the GPIO, MIPI, DDR or PLL resources, connect the pins as shown in the following table.

**Table 58: Connection Requirements for Unused Resources**

Unused Resource	Pin	Note
GPIO Bank	VCCIOxx	Connect to either 1.8 V, 2.5 V, or 3.3 V.
PLL	VCCA_PLL	Connect to VCC.
MIPI	VCC12A_MIPI_TX	Connect to VCC.
	VCC12A_MIPI_RX	Connect to VCC.
	VCC25A_MIPI	Connect to VCC.
DDR	VCCIO_DDR	Floating. Leave unconnected.
	DDR_VREF	Connect to ground.



**Note:** Refer to **Configuration Timing** on page 56 and **MIPI Power-Up Timing** on page 54 for timing information.

**Figure 26: Trion® FPGAs Power Up Sequence**

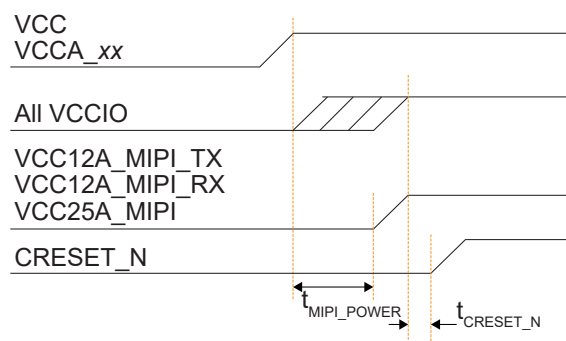

## Power Supply Current Transient

You may observe an inrush current on the dedicated power rail during power-up. You must ensure that the power supplies selected in your board meets the current requirement during power-up and the estimated current during user mode. Use the Power Estimator to calculate the estimated current during user mode.

*Table 59: Maximum Power Supply Current Transient*

Power Supply	Maximum Power Supply Current Transient <sup>(10)(11)</sup>	Unit
VCC	57	mA

## Configuration

The T35 FPGA contains volatile Configuration RAM (CRAM). The user must configure the CRAM for the desired logic function upon power-up and before the FPGA enters normal operation. The FPGA's control block manages the configuration process and uses a bitstream to program the CRAM. The Efinity<sup>®</sup> software generates the bitstream, which is design dependent. You can configure the T35 FPGA(s) in active, passive, or JTAG mode.



**Learn more:** Refer to [AN 006: Configuring Trion FPGAs](#) for details on the dedicated configuration pins and how to configure FPGA(s).

*Figure 27: High-Level Configuration Options*

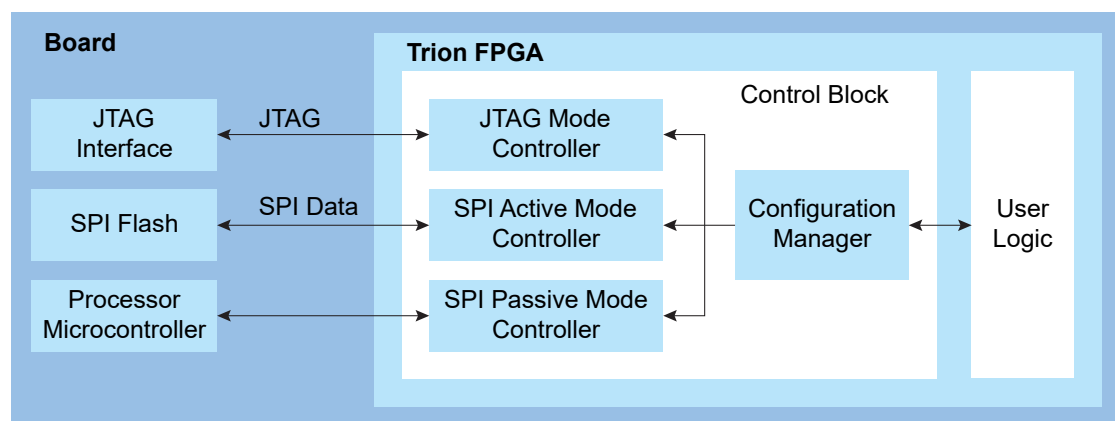

In active mode, the FPGA controls the configuration process. An oscillator circuit within the FPGA provides the configuration clock. The bitstream is typically stored in an external serial flash device, which provides the bitstream when the FPGA requests it.

The control block sends out the instruction and address to read the configuration data. First, it issues a release from power-down instruction to wake up the external SPI flash. Then, it waits for at least 30  $\mu$ s before issuing a fast read command to read the content of SPI flash from address 24h'000000.

<sup>(10)</sup> Inrush current for other power rails are not significant in Trion<sup>®</sup> FPGAs.

<sup>(11)</sup> Measured at room temperature.

In passive mode, the FPGA is the slave and relies on an external master to provide the control, bitstream, and clock for configuration. Typically the master is a microcontroller or another FPGA in active mode.

In JTAG mode, you configure the FPGA via the JTAG interface.

## Supported Configuration Modes

Table 60: T35 Configuration Modes by Package

Configuration Mode	Width	BGA324, BGA400
Active	x1	✓ <sup>(12)</sup>
	x2	✓
	x4	✓
Passive	x1	✓
	x2	✓
	x4	✓
	x8	✓
	x16	✓
	x32	✓
JTAG	x1	✓



**Learn more:** Refer to [AN 006: Configuring Trion FPGAs](#) for more information.

<sup>(12)</sup> This package does not support active SPI multi-image configuration in x1 mode. Instead, use x2 or x4, or alternatively, use the internal reconfiguration feature as described in AN 010: Using the Internal Reconfiguration Feature to Remotely Update Trion FPGAs.

## DC and Switching Characteristics

**Table 61: Absolute Maximum Ratings**

Conditions beyond those listed may cause permanent damage to the device. Device operation at the absolute maximum ratings for extended periods of time has adverse effects on the device.

Symbol	Description	Min	Max	Units
VCC	Core power supply	-0.5	1.42	V
VCCIO	I/O bank power supply	-0.5	4.6	V
VCCA_PLL	PLL analog power supply	-0.5	1.42	V
VCCIO_DDR	DDR power supply	-0.5	1.65	V
VCC25A_MIP10 VCC25A_MIP11	2.5 V analog power supply for MIPI	-0.5	2.75	V
VCC12A_MIP10_TX VCC12A_MIP11_TX	1.2 V TX analog power supply for MIPI	-0.5	1.42	V
VCC12A_MIP10_RX VCC12A_MIP11_RX	1.2 V RX analog power supply for MIPI	-0.5	1.42	V
V <sub>IN</sub>	I/O input voltage	-0.5	4.6	V
T <sub>J</sub>	Operating junction temperature	-40	125	°C
T <sub>STG</sub>	Storage temperature, ambient	-55	150	°C

**Table 62: Recommended Operating Conditions (C3, C4, and I4 Speed Grades)<sup>(13)</sup>**

Symbol	Description	Min	Typ	Max	Units
VCC	Core power supply	1.15	1.2	1.25	V
VCCIO	1.8 V I/O bank power supply	1.71	1.8	1.89	V
	2.5 V I/O bank power supply	2.38	2.5	2.63	V
	3.3 V I/O bank power supply	3.14	3.3	3.47	V
VCCIO_DDR	DDR3	1.425	1.5	1.575	V
	DDR3L	1.283	1.35	1.45	V
	LPDDR3	1.14	1.2	1.3	V
	LPDDR2	1.14	1.2	1.3	V
VCCA_PLL	PLL analog power supply	1.15	1.2	1.25	V
VCC25A_MIP10 VCC25A_MIP11	2.5 V analog power supply for MIPI	2.38	2.5	2.63	V
VCC12A_MIP10_TX VCC12A_MIP11_TX	1.2 V TX analog power supply for MIPI	1.15	1.2	1.25	V
VCC12A_MIP10_RX VCC12A_MIP11_RX	1.2 V RX analog power supply for MIPI	1.15	1.2	1.25	V

<sup>(13)</sup> Supply voltage specification applied to the voltage taken at the device pins with respect to ground, not at the power supply.

Symbol	Description	Min	Typ	Max	Units
V <sub>IN</sub>	I/O input voltage <sup>(14)</sup>	-0.3	-	VCCIO + 0.3	V
T <sub>JCOM</sub>	Operating junction temperature, commercial	0	-	85	°C
T <sub>JIND</sub>	Operating junction temperature, industrial	-40	-	100	°C

**Table 63: Recommended Operating Conditions (C4L and I4L Speed Grades)<sup>(13)</sup>**

Symbol	Description	Min	Typ	Max	Units
VCC	Core power supply	1.05	1.1	1.15	V
VCCIO	1.8 V I/O bank power supply	1.71	1.8	1.89	V
	2.5 V I/O bank power supply	2.38	2.5	2.63	V
	3.3 V I/O bank power supply	3.14	3.3	3.47	V
VCCIO_DDR	DDR3	1.425	1.5	1.575	V
	DDR3L	1.283	1.35	1.45	V
	LPDDR3	1.14	1.2	1.3	V
	LPDDR2	1.14	1.2	1.3	V
VCCA_PLL	PLL analog power supply	1.05	1.1	1.15	V
VCC25A_MIP10 VCC25A_MIP11	2.5 V analog power supply for MIPI	2.38	2.5	2.63	V
VCC12A_MIP10_TX VCC12A_MIP11_TX	1.2 V TX analog power supply for MIPI	1.05	1.1	1.15	V
VCC12A_MIP10_RX VCC12A_MIP11_RX	1.2 V RX analog power supply for MIPI	1.05	1.1	1.15	V
V <sub>IN</sub>	I/O input voltage <sup>(15)</sup>	-0.3	-	VCCIO + 0.3	V
T <sub>JCOM</sub>	Operating junction temperature, commercial	0	-	85	°C
T <sub>JIND</sub>	Operating junction temperature, industrial	-40	-	100	°C

**Table 64: Power Supply Ramp Rates**

Symbol	Description	Min	Max	Units
t <sub>RAMP</sub>	Power supply ramp rate for all supplies.	VCCIO/0.01	10	V/ms

<sup>(14)</sup> Values applicable to both input and tri-stated output configuration.

<sup>(15)</sup> Values applicable to both input and tri-stated output configuration.

**Table 65: Single-Ended I/O DC Electrical Characteristics**

I/O Standard	V <sub>IL</sub> (V)		V <sub>IH</sub> (V)		V <sub>OL</sub> (V)	V <sub>OH</sub> (V)
	Min	Max	Min	Max	Max	Min
3.3 V LVCMOS	-0.3	0.8	2	VCCIO + 0.3	0.2	VCCIO - 0.2
3.3 V LVTTTL	-0.3	0.8	2	VCCIO + 0.3	0.4	2.4
2.5 V LVCMOS	-0.3	0.7	1.7	VCCIO + 0.3	0.5	1.8
1.8 V LVCMOS	-0.3	0.35 * VCCIO	0.65 * VCCIO	VCCIO + 0.3	0.45	VCCIO - 0.45

**Table 66: Single-Ended I/O and Dedicated Configuration Pins Schmitt Trigger Buffer Characteristic**

Voltage (V)	V <sub>T+</sub> (V) Schmitt Trigger Low-to-High Threshold	V <sub>T-</sub> (V) Schmitt Trigger High-to-Low Threshold	Input Leakage Current (μA)	Tri-State Output Leakage Current (μA)
3.3	1.73	1.32	±10	±10
2.5	1.37	1.01	±10	±10
1.8	1.05	0.71	±10	±10

**Table 67: Single-Ended I/O Buffer Drive Strength Characteristics**

Junction temperature at T<sub>J</sub> = 25 °C, power supply at nominal voltage.

CDONE and CRESET\_N have a drive strength of 1.

I/O Standard	3.3 V		2.5 V		1.8 V	
	I <sub>OH</sub> (mA)	I <sub>OL</sub> (mA)	I <sub>OH</sub> (mA)	I <sub>OL</sub> (mA)	I <sub>OH</sub> (mA)	I <sub>OL</sub> (mA)
1	14.4	8.0	9.1	8.0	4.4	5.1
2	19.1	10.5	12.2	10.5	5.8	6.8
3	23.9	13.3	15.2	13.4	7.3	8.6
4	28.7	15.8	18.2	15.9	8.6	10.3

**Table 68: Single-Ended I/O Internal Weak Pull-Up and Pull-Down Resistance**

CDONE and CRESET\_N also have an internal weak pull-up with these values.

I/O Standard	Internal Pull-Up			Internal Pull-Down			Units
	Min	Typ	Max	Min	Typ	Max	
3.3 V LVTTTL/LVCMOS	27	40	65	30	47	83	kΩ
2.5 V LVCMOS	35	55	95	37	62	118	kΩ
1.8 V LVCMOS	53	90	167	54	99	202	kΩ

**Table 69: LVDS Pins Configured as Single-Ended I/O DC Electrical Characteristics**

I/O Standard	V <sub>IL</sub> (V)		V <sub>IH</sub> (V)		V <sub>OL</sub> (V)	V <sub>OH</sub> (V)
	Min	Max	Min	Max	Max	Min
3.3 V LVCMOS	-0.3	0.8	2	VCCIO + 0.3	0.2	VCCIO - 0.2
3.3 V LVTTTL	-0.3	0.8	2	VCCIO + 0.3	0.4	2.4
2.5 V LVCMOS	-0.3	0.7	1.7	VCCIO + 0.3	0.5	1.8
1.8 V LVCMOS	-0.3	0.35 * VCCIO	0.65 * VCCIO	VCCIO + 0.3	0.45	VCCIO - 0.45

**Table 70: LVDS Pins Configured as Single-Ended I/O DC Electrical Characteristics**

Voltage (V)	Input Leakage Current (μA)	Tri-State Output Leakage Current (μA)
3.3	±10	±10

**Table 71: LVDS Pins Configured as Single-Ended I/O Buffer Drive Strength Characteristics**

Junction temperature at T<sub>J</sub> = 25 °C, power supply at nominal voltage.

I/O Standard	3.3 V		2.5 V		1.8 V	
	I <sub>OH</sub> (mA)	I <sub>OL</sub> (mA)	I <sub>OH</sub> (mA)	I <sub>OL</sub> (mA)	I <sub>OH</sub> (mA)	I <sub>OL</sub> (mA)
1	14.4	8.0	9.1	8.0	4.4	5.1
2	19.1	10.5	12.2	10.5	5.8	6.8
3	23.9	13.3	15.2	13.4	7.3	8.6
4	28.7	15.8	18.2	15.9	8.6	10.3

**Table 72: LVDS Pins Configured as Single-Ended I/O Internal Weak Pull-Up Resistance**

I/O Standard	Internal Pull-Up			Units
	Min	Typ	Max	
3.3 V LVTTTL/LVCMOS	27	40	65	kΩ
2.5 V LVCMOS	35	55	95	kΩ
1.8 V LVCMOS	53	90	167	kΩ

**Table 73: Single-Ended I/O and LVDS Pins Configured as Single-Ended I/O Rise and Fall Time**

Data are based on the following IBIS simulation setup:

- Weakest drive strength model
- Typical simulation corner setting
- RLC circuit with 6.6 pF capacitance, 16.6 nH inductance, 0.095 ohm resistance, and 25 °C temperature



**Note:** For a more accurate data, you need to perform the simulation with your own circuit.

I/O Standard	Rise Time ( $T_R$ )		Fall Time ( $T_F$ )		Units
	Slow Slew Rate Enabled	Slow Slew Rate Disabled	Slow Slew Rate Enabled	Slow Slew Rate Disabled	
3.3 V LVTTTL/LVCMOS	1.13	1.02	1.24	1.17	ns
2.5 V LVCMOS	1.4	1.3	1.44	1.31	ns
1.8 V LVCMOS	2.14	2.01	2.05	1.85	ns
LVDS pins configured as 3.3 V LVTTTL/LVCMOS	0.45		0.44		ns

**Table 74: Maximum Toggle Rate**

I/O Standard	Test Condition Load (pF)	Max Toggle Rate (Mbps)
3.3 V LVTTTL/LVCMOS	10	400
2.5 V LVCMOS	10	400
1.8 V LVCMOS	10	400
LVDS	10	800

**Table 75: Block RAM Characteristics**

Symbol	Description	Speed Grade		Units
		C3, C4L, I4L	C4, I4	
$f_{MAX}$	Block RAM maximum frequency.	310	400	MHz

**Table 76: Multiplier Block Characteristics**

Symbol	Description	Speed Grade		Units
		C3, C4L, I4L	C4, I4	
$f_{MAX}$	Multiplier block maximum frequency.	310	400	MHz

# LVDS I/O Electrical and Timing Specifications

The LVDS pins comply with the EIA/TIA-644 electrical specifications.



**Note:** The LVDS RX supports the sub-lvds, slvs, HiVcm, RSDS and 3.3 V LVPECL differential I/O standards with a transfer rate of up to 800 Mbps.

**Table 77: LVDS I/O Electrical Specifications**

Parameter	Description	Test Conditions	Min	Typ	Max	Unit
V <sub>CCIO</sub>	LVDS I/O Supply Voltage	-	2.97	3.3	3.63	V
<b>LVDS TX</b>						
V <sub>OD</sub>	Output Differential Voltage	-	250	-	450	mV
ΔV <sub>OD</sub>	Change in V <sub>OD</sub>	-	-	-	50	mV
V <sub>OCM</sub>	Output Common Mode Voltage	RT = 100 Ω	1,125	1,250	1,375	mV
ΔV <sub>OCM</sub>	Change in V <sub>OCM</sub>	-	-	-	50	mV
V <sub>OH</sub>	Output High Voltage	RT = 100 Ω	-	-	1,600	mV
V <sub>OL</sub>	Output Low Voltage	RT = 100 Ω	900	-	-	mV
I <sub>SAB</sub>	Output Short Circuit Current	-	-	-	24	mA
<b>LVDS RX</b>						
V <sub>ID</sub>	Input Differential Voltage	-	100	-	600	mV
V <sub>ICM</sub>	Input Common Mode Voltage	-	100	-	2,000	mV
V <sub>TH</sub>	Differential Input Threshold	-	-100	-	100	mV
I <sub>IL</sub>	Input Leakage Current	-	-	-	20	μA

**Figure 28: LVDS RX I/O Electrical Specification Waveform**

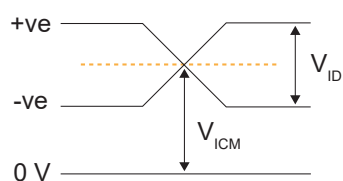

**Table 78: LVDS Timing Specifications**

Parameter	Description	Min	Typ	Max	Unit
t <sub>LVDS_DT</sub>	LVDS TX reference clock output duty cycle	45	50	55	%
t <sub>LVDS_skew</sub>	LVDS TX lane-to-lane skew	-	200	-	ps

## ESD Performance

Refer to the [Trion Reliability Report](#) for ESD performance data.

# MIPI Electrical Specifications and Timing

The MIPI D-PHY transmitter and receiver are compliant to the MIPI Alliance Specification for D-PHY Revision 1.1.

**Table 79: High-Speed MIPI D-PHY Transmitter (TX) DC Specifications**

Parameter	Description	Min	Typ	Max	Unit
$V_{CMTX}$	High-speed transmit static common-mode voltage	150	200	250	mV
$ \Delta V_{CMTX(1,0)} $	$V_{CMTX}$ mismatch when output is Differential-1 or Differential-0	-	-	5	mV
$ V_{OD} $	High-speed transmit differential voltage	140	200	270	mV
$ \Delta V_{CMTX} $	VOD mismatch when output is Differential-1 or Differential-0	-	-	14	mV
$V_{OHHS}$	High-speed output high voltage	-	-	360	mV
$Z_{OS}$	Single ended output impedance	40	50	62.5	$\Omega$
$\Delta Z_{OS}$	Single ended output impedance mismatch	-	-	10	%

**Table 80: Low-Power MIPI D-PHY Transmitter (TX) DC Specifications**

Parameter	Description	Min	Typ	Max	Unit
$V_{OH}$	Thevenin output high level	0.99	-	1.21	V
$V_{OL}$	Thevenin output low level	-50	-	50	mV
$Z_{OLP}$	Output impedance of low-power transmitter	110	-	-	$\Omega$

**Table 81: High-Speed MIPI D-PHY Receiver (RX) DC Specifications**

Parameter	Description	Min	Typ	Max	Unit
$V_{CMRX(DC)}$	Common mode voltage high-speed receive mode	70	-	330	mV
$V_{IDTH}$	Differential input high threshold	-	-	70	mV
$V_{IDTL}$	Differential input low threshold	-70	-	-	mV
$V_{IHHS}$	Single-ended input high voltage	-	-	460	mV
$V_{ILHS}$	Single-ended input low voltage	-40	-	-	mV
$V_{TERM-EN}$	Single-ended threshold for high-speed termination enable	-	-	450	mV
$Z_{ID}$	Differential input impedance	80	100	125	$\Omega$

**Table 82: Low-Power MIPI D-PHY Receiver (RX) DC Specifications**

Parameter	Description	Min	Typ	Max	Unit
$V_{IH}$	Logic 1 input voltage	880	-	-	mV
$V_{IL}$	Logic 0 input voltage, not in ULP state	-	-	550	mV
$V_{IL-ULPS}$	Logic 0 input voltage, ULP state	-	-	300	mV
$V_{HYST}$	Input hysteresis	25	-	-	mV

## MIPI Power-Up Timing

Apply power to VCC12A\_MIPI\_TX, VCC12A\_MIPI\_RX, and VCC25A\_MIPI at least  $t_{\text{MIPI\_POWER}}$  after VCC is stable. See **Power Up Sequence** on page 44 for a power-up sequence diagram.

Table 83: MIPI Timing

Symbol	Parameter	Min	Typ	Max	Units
$t_{\text{MIPI\_POWER}}$	Minimum time after VCC and VCCA <sub>xx</sub> are stable before powering VCC12A_MIPI_TX, VCC12A_MIPI_RX, and VCC25A_MIPI.	1	-	-	$\mu\text{s}$

## MIPI Reset Timing

The MIPI RX and TX interfaces have two signals (RSTN and DPHY\_RSTN) to reset the CSI-2 and D-PHY controller logic. These signals are active low, and you should use them together to reset the MIPI interface.

The following waveform illustrates the minimum time required to reset the MIPI interface.

Figure 29: RSTN and DPHY\_RSTN Timing Diagram

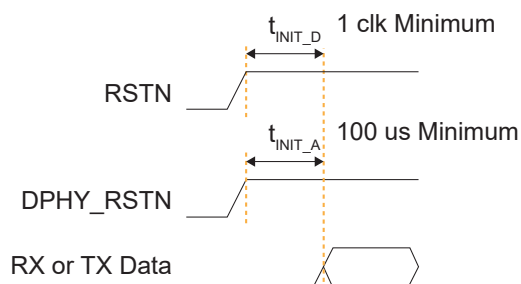

Table 84: MIPI Timing

Symbol	Parameter	Min	Typ	Max	Units
$t_{\text{INIT\_A}}$	Minimum time between the rising edge of DPHY_RSTN and the start of MIPI RX or TX data.	100	-	-	$\mu\text{s}$
$t_{\text{INIT\_D}}$	Minimum time between the rising edge of RSTN and the start of MIPI RX or TX data.	1	-	-	clk

## PLL Timing and AC Characteristics

The following tables describe the PLL timing and AC characteristics.

**Table 85: PLL Timing**

Symbol	Parameter	Min	Typ	Max	Units
$F_{IN}^{(16)}$	Input clock frequency from core.	10	-	330	MHz
	Input clock frequency from GPIO.	10	-	200	MHz
	Input clock frequency from LVDS.	10	-	400	MHz
$F_{OUT}$	Output clock frequency.	0.24	-	500	MHz
$F_{OUT}$	Output clock frequency for PLL BR0 CLKOUT0 (DDR PHY input clock).	0.24	-	800	MHz
$F_{VCO}$	PLL VCO frequency.	500	-	1,600	MHz
$F_{PPD}$	Phase frequency detector input frequency.	10	-	50	MHz

**Table 86: PLL AC Characteristics<sup>(17)</sup>**

Symbol	Parameter	Min	Typ	Max	Units
$t_{DT}$	Output clock duty cycle.	40	50	60	%
$t_{OPJIT}^{(PK - PK)}$ (18)	Output clock period jitter (PK-PK).	-	-	200	ps
$t_{ILJIT}^{(PK - PK)}$	Input clock long-term jitter (PK-PK)	-	-	800	ps
$t_{LOCK}$	PLL lock-in time.	-	-	0.5	ms

<sup>(16)</sup> When using the Dynamic clock source mode, the maximum input clock frequency is limited by the slowest clock frequency of the assigned clock source. For example, the maximum input clock frequency of a Dynamic clock source mode from core and GPIO is 200 MHz.

<sup>(17)</sup> Test conditions at 3.3 V and room temperature.

<sup>(18)</sup> The output jitter specification applies to the PLL jitter when an input jitter of 20 ps is applied.

# Configuration Timing

The T35 FPGA has the following configuration timing specifications. Refer to [AN 006: Configuring Trion FPGAs](#) for detailed configuration information.

## Timing Waveforms

Figure 30: SPI Active Mode (x1) Timing Sequence

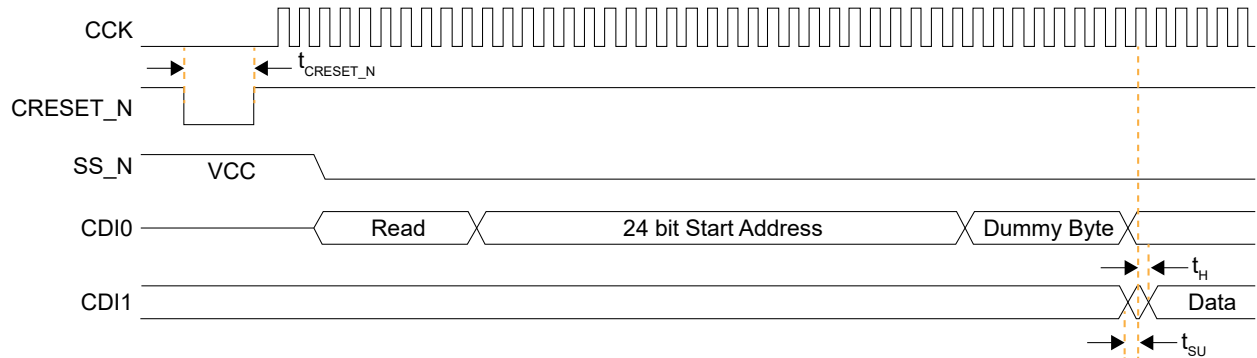

Figure 31: SPI Passive Mode (x1) Timing Sequence

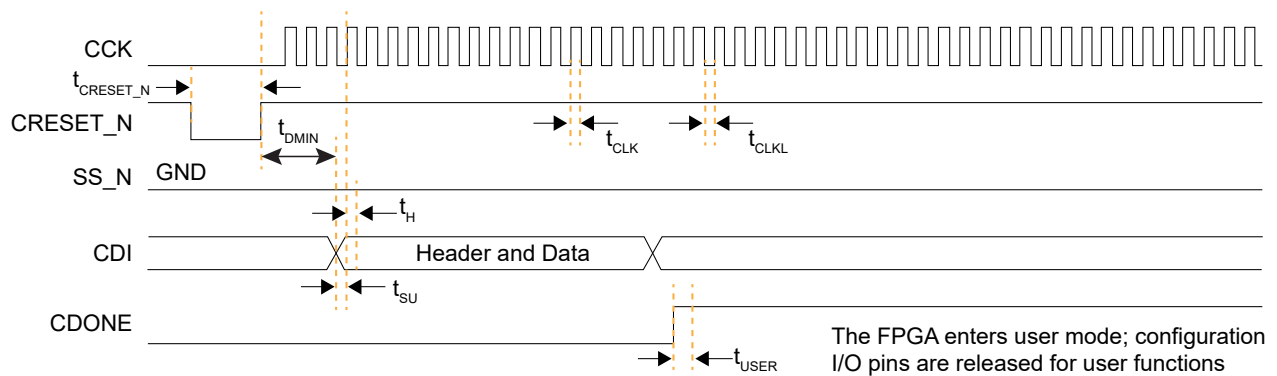
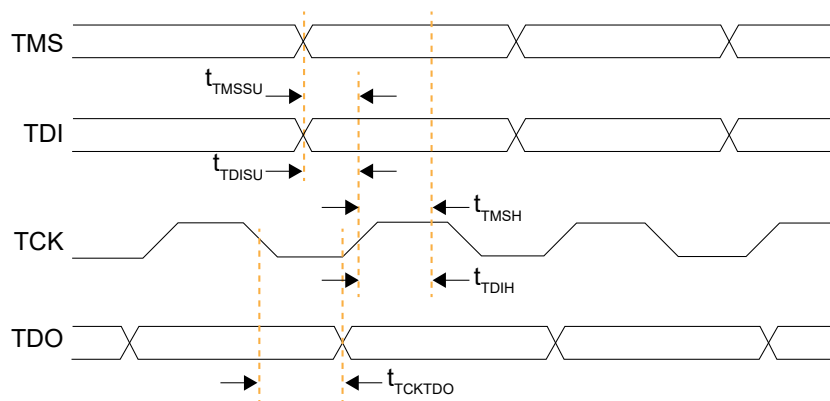

Figure 32: Boundary-Scan Timing Waveform



## Timing Parameters

**Table 87: All Modes**

Symbol	Parameter	Min	Typ	Max	Units
t <sub>CRESET_N</sub>	Minimum creset_n low pulse width required to trigger re-configuration.	320	-	-	ns
t <sub>USER</sub>	Minimum configuration duration after CDONE goes high before entering user mode. <sup>(19)(20)</sup> Test condition at 10 k $\Omega$ pull-up resistance and 10 pF output loading on CDONE pin.	25	-	(21)	$\mu$ s

**Table 88: Active Mode**

Symbol	Parameter	Frequency	Min	Typ	Max	Units
f <sub>MAX_M</sub>	Active mode configuration clock frequency. <sup>(22)</sup>	DIV4	14	20	26	MHz
		DIV8	7	10	13	MHz
t <sub>SU</sub>	Setup time. Test condition at 3.3 V I/O standard and 0 pF output loading.	-	7.5	-	-	ns
t <sub>H</sub>	Hold time. Test condition at 3.3 V I/O standard and 0 pF output loading.	-	1	-	-	ns

**Table 89: Passive Mode**

Symbol	Parameter	Min	Typ	Max	Units
f <sub>MAX_S</sub>	Passive mode X1 configuration clock frequency.	-	-	25	MHz
	Passive mode X2, X4 or X8 configuration clock frequency.	-	-	50	MHz
	Passive mode X16 or X32 configuration clock frequency.	-	-	100	MHz
t <sub>CLKH</sub>	Configuration clock pulse width high.	$0.48 \cdot 1 / f_{MAX\_S}$	-	-	ns
t <sub>CLKL</sub>	Configuration clock pulse width low.	$0.48 \cdot 1 / f_{MAX\_S}$	-	-	ns
t <sub>SU</sub>	Setup time.	6.5	-	-	ns
t <sub>H</sub>	Hold time.	1	-	-	ns
t <sub>DMIN</sub>	Minimum time between deassertion of CRESET_N to first valid configuration data.	1.2	-	-	$\mu$ s

<sup>(19)</sup> The FPGA may go into user mode before t<sub>USER</sub> has elapsed. However, Efinix recommends that you keep the system interface to the FPGA in reset until t<sub>USER</sub> has elapsed.

<sup>(20)</sup> For JTAG programming, the min t<sub>USER</sub> configuration time is required after CDONE goes high and FPGA receives the ENTERUSER instruction from JTAG host (TAP controller in UPDATE\_IR state).

<sup>(21)</sup> See **Maximum t<sub>USER</sub> for SPI Active and Passive Modes** on page 58

<sup>(22)</sup> For parallel daisy chain x2 and x4, the active configuration clock frequency, f<sub>MAX\_M</sub>, is required to set to DIV4.

Table 90: JTAG Mode

Symbol	Parameter	Min	Typ	Max	Units
$f_{TCK}$	TCK frequency.	-	-	25	MHz
$t_{DISU}$	TDI setup time.	3.5	-	-	ns
$t_{DIH}$	TDI hold time.	2.5	-	-	ns
$t_{MSSU}$	TMS setup time.	3	-	-	ns
$t_{MSH}$	TMS hold time.	2.5	-	-	ns
$t_{CKTDO}$	TCK falling edge to TDO output.	-	-	10.5	ns

## Maximum $t_{USER}$ for SPI Active and Passive Modes

The following waveform illustrates the minimum and maximum values for  $t_{USER}$ .

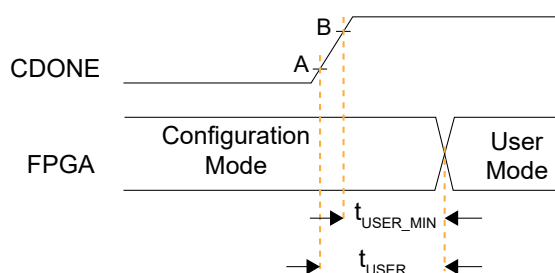

- *Point A*—User-defined trigger point to start counter on  $t_{USER}$
- *Point B*— $V_{IH}$  (with Schmitt Trigger) of Trion I/Os

The maximum  $t_{USER}$  value can be derived based on the following formula:

Table 91:  $t_{USER}$  Maximum

Configuration Setup	$t_{USER}$ Maximum
Single Trion FPGA	$t_{USER} = t_{(from\ A\ to\ B)} + t_{USER\_MIN}$
Slave FPGA in a dual-Trion FPGA SPI chain	
Master FPGA in a dual-Trion FPGA SPI chain	$t_{USER} = (1344 / SPI\_WIDTH) * CCK\ period + t_{USER\_MIN} + t_{(from\ A\ to\ B)}$

# Pinout Description

The following tables describe the pinouts for power, ground, configuration, and interfaces.

**Table 92: General Pinouts**

Function	Group	Direction	Description
VCC	Power	-	Core power supply.
VCCA <sub>xx</sub>	Power	-	PLL analog power supply. <i>xx</i> indicates the location.
VCCIO <sub>xx</sub>	Power	-	I/O pin power supply. <i>xx</i> indicates the bank location.
VCCIO <sub>xx_yy_zz</sub>	Power	-	Power for I/O banks that are shorted together. <i>xx</i> , <i>yy</i> , and <i>zz</i> are the bank locations. For example: VCCIO1B_1C shorts banks 1B and 1C VCCIO3C_TR_BR shorts banks 3C, TR, and BR
GND	Ground	-	Ground.
CLK <sub>n</sub>	Alternate	Input	Global clock network input. <i>n</i> is the number. The number of inputs is package dependent.
CTRL <sub>n</sub>	Alternate	Input	Global network input used for high fanout and global reset. <i>n</i> is the number. The number of inputs is package dependent.
PLLIN	Alternate	Input	PLL reference clock resource. There are 7 PLL reference clock resource assignments. Assign the reference clock resource based on the PLL you are using.
MREFCLK	Alternate	Input	MIPI PLL reference clock source.
GPIO <sub>x_n</sub>	GPIO	I/O	General-purpose I/O for user function. User I/O pins are single-ended. <i>x</i> : Indicates the bank (L or R) <i>n</i> : Indicates the GPIO number.
GPIO <sub>x_n_yyy</sub> GPIO <sub>x_n_yyy_zzz</sub> GPIO <sub>x_zzzn</sub>	GPIO Multi-Function	I/O	Multi-function, general-purpose I/O. These pins are single ended. If these pins are not used for their alternate function, you can use them as user I/O pins. <i>n</i> : Indicates the GPIO number. <i>yyy</i> , <i>yyy_zzz</i> : Indicates the alternate function. <i>zzzn</i> : Indicates LVDS TX or RX and number.
TXN <sub>n</sub> , TXP <sub>n</sub>	LVDS	I/O	LVDS transmitter (TX). <i>n</i> : Indicates the number.
RXN <sub>n</sub> , RXP <sub>n</sub>	LVDS	I/O	LVDS receiver (RX). <i>n</i> : Indicates the number.
CLKN <sub>n</sub> , CLKP <sub>n</sub>	LVDS	I/O	Dedicated LVDS receiver clock input. <i>n</i> : Indicates the number.
RXN <sub>n_EXTFBn</sub> RXP <sub>n_EXTFBn</sub>	LVDS	I/O	LVDS PLL external feedback. <i>n</i> : Indicates the number.
REF_RES	-	-	REF_RES is a reference resistor to generate constant current for LVDS TX. Connect a 12 kΩ resistor with a tolerance of ±1% to the REF_RES pin with respect to ground. If none of the pins in a bank are used for LVDS, leave this pin floating.

**Table 93: Dedicated Configuration Pins**

These pins cannot be used as general-purpose I/O after configuration.

Pins	Direction	Description	Use External Weak Pull-Up
CDONE	Output	Configuration done status pin. CDONE is an open drain output; connect it to an external pull-up resistor to VCCIO. When CDONE = 1, configuration is complete. If you hold CDONE low, the device will not enter user mode.	✓
CRESET_N	Input	Initiates FPGA re-configuration (active low). Pulse CRESET_N low for a duration of $t_{\text{creset\_N}}$ before asserting CRESET_N from low to high to initiate FPGA re-configuration. This pin does not perform a system reset.	✓
TCK	Input	JTAG test clock input (TCK). The rising edge loads signals applied at the TAP input pins (TMS and TDI). The falling edge clocks out signals through the TAP TDO pin.	✓
TMS	Input	JTAG test mode select input (TMS). The I/O sequence on this input controls the test logic operation. The signal value typically changes on the falling edge of TCK. TMS is typically a weak pull-up; when it is not driven by an external source, the test logic perceives a logic 1.	✓
TDI	Input	JTAG test data input (TDI). Data applied at this serial input is fed into the instruction register or into a test data register depending on the sequence previously applied at TMS. Typically, the signal applied at TDI changes state following the falling edge of TCK while the registers shift in the value received on the rising edge. Like TMS, TDI is typically a weak pull-up; when it is not driven from an external source, the test logic perceives a logic 1.	✓
TDO	Output	JTAG test data output (TDO). This serial output from the test logic is fed from the instruction register or from a test data register depending on the sequence previously applied at TMS. During shifting, data applied at TDI appears at TDO after a number of cycles of TCK determined by the length of the register included in the serial path. The signal driven through TDO changes state following the falling edge of TCK. When data is not being shifted through the device, TDO is set to an inactive drive state (e.g., high-impedance).	✓



**Note:** All dedicated configuration pins have Schmitt Trigger buffer. See [Table 66: Single-Ended I/O and Dedicated Configuration Pins Schmitt Trigger Buffer Characteristic](#) on page 49 for the Schmitt Trigger buffer specifications.

**Table 94: Dual-Purpose Configuration Pins**

In user mode (after configuration), you can use these dual-purpose pins as general I/O.

Pins	Direction	Description	Use External Weak Pull-Up
CBUS[2:0]	Input	Configuration bus width select. Connect to weak pull-up resistors if using default mode (x1).	✓
CBSEL[1:0]	Input	Optional multi-image selection input (if external multi-image configuration mode is enabled).	N/A
CCK	I/O	Passive SPI input configuration clock or active SPI output configuration clock (active low). Includes an internal weak pull-up.	N/A
CDIn	I/O	<i>n</i> is a number from 0 to 31 depending on the SPI configuration. 0: Passive serial data input or active serial output. 1: Passive serial data output or active serial input. <i>n</i> : Parallel I/O. In multi-bit daisy chain connection, the CDIn (31:0) connects to the data bus in parallel.	N/A
CSI	Input	Chip select. 0: The FPGA is not selected or enabled and will not be configured. 1: Selects the FPGA for configuration (SPI and JTAG configuration).	✓
CSO	Output	Chip select output. Selects the next device for cascading configuration.	N/A
NSTATUS	Output	Status (active low). Indicates a configuration error. When the FPGA drives this pin low, it indicates an ID mismatch, the bitstream CRC check has failed, or remote update has failed.	N/A
SS_N	Input	SPI slave select (active low). Includes an internal weak pull-up resistor to VCCIO during configuration. During configuration, the logic level samples on this pin determine the configuration mode. This pin is an input when sampled at the start of configuration (SS is low); an output in active SPI flash configuration mode. The FPGA senses the value of SS_N when it comes out of reset (pulse CRESET_N low to high). 0: Passive mode 1: Active mode	✓
TEST_N	Input	Active-low test mode enable signal. Set to 1 to disable test mode. During configuration, rely on the external weak pull-up or drive this pin high.	✓
RESERVED_OUT	Output	Reserved pin during user configuration. This pin drives high during user configuration. BGA49 and BGA81 packages only.	N/A

**Table 95: MIPI Pinouts (Dedicated)**

*n* Indicates the number. *L* indicates the lane

Function	Group	Direction	Description
VCC25A_MIPI0 VCC25A_MIPI1	Power	-	MIPI 2.5 V analog power supply.
VCC12A_MIPI0_TX VCC12A_MIPI1_TX	Power	-	MIPI 1.2 V TX analog power supply.
VCC12A_MIPI0_RX VCC12A_MIPI1_RX	Power	-	MIPI 1.2 V RX analog power supply.
GNDA_MIPI	Ground	-	Ground for MIPI analog power supply.
MIPI <sub>n</sub> _TXDPL MIPI <sub>n</sub> _TXDNL	MIPI	I/O	MIPI differential transmit data lane.
MIPI <sub>n</sub> _RXDPL MIPI <sub>n</sub> _RXDNL	MIPI	I/O	MIPI differential receive data lane.
MREFCLK	Clock	Input	MIPI PLL reference clock source.

**Table 96: DDR Pinouts (Dedicated)**

*n* indicates the number.

Function	Direction	Description
VCCIO_DDR	-	DDR power supply.
DDR_A[ <i>n</i> ]	Output	Address signals to the memories.
DDR_BA[ <i>n</i> ]	Output	Bank signals to the memories.
DDR_CAS_N	Output	Active-low column address strobe signal to the memories.
DDR_CKE	Output	Active-high clock enable signals to the memories.
DDR_CK DDR_CK_N	Output	Differential clock output pins to the memories.
DDR_CS_N	Output	Active-low chip select signals to the memories.
DDR_DQ[ <i>n</i> ]	I/O	Data bus to/from the memories.
DDR_DM[ <i>n</i> ]	Output	Active-high data-mask signals to the memories.
DDR_DQS_N[ <i>n</i> ]	I/O	Differential data strobes to/from the memories.
DDR_DQS[ <i>n</i> ]	I/O	Differential data strobes to/from the memories.
DDR_ODT	Output	ODT signal to the memories.
DDR_RAS_N	Output	Active-low row address strobe signal to the memories.
DDR_RST_N	Output	Active-low reset signals to the memories.
DDR_WE_N	Output	Active-low write enable strobe signal to the memories.
DDR_VREF	I/O	Reference voltage.
DDR_ZQ	I/O	ZQ calibration pin.

# Efinity Software Support

The Efinity® software provides a complete tool flow from RTL design to bitstream generation, including synthesis, place-and-route, and timing analysis. The software has a graphical user interface (GUI) that provides a visual way to set up projects, run the tool flow, and view results. The software also has a command-line flow and Tcl command console. The Efinity® software supports simulation flows using the ModelSim, NCSim, or free iVerilog simulators. An integrated hardware Debugger with Logic Analyzer and Virtual I/O debug cores helps you probe signals in your design. The software-generated bitstream file configures the T35 FPGA. The software supports the Verilog HDL and VHDL languages.

## T35 Interface Floorplan

**Note:** The numbers in the floorplan figures indicate the GPIO and LVDS number ranges. Some packages may not have all GPIO or LVDS pins in the range bonded out. Refer to the **T35 pinout** for information on which pins are available in each package.

Figure 33: Floorplan Diagram for BGA324 Packages (with DDR and MIPI)

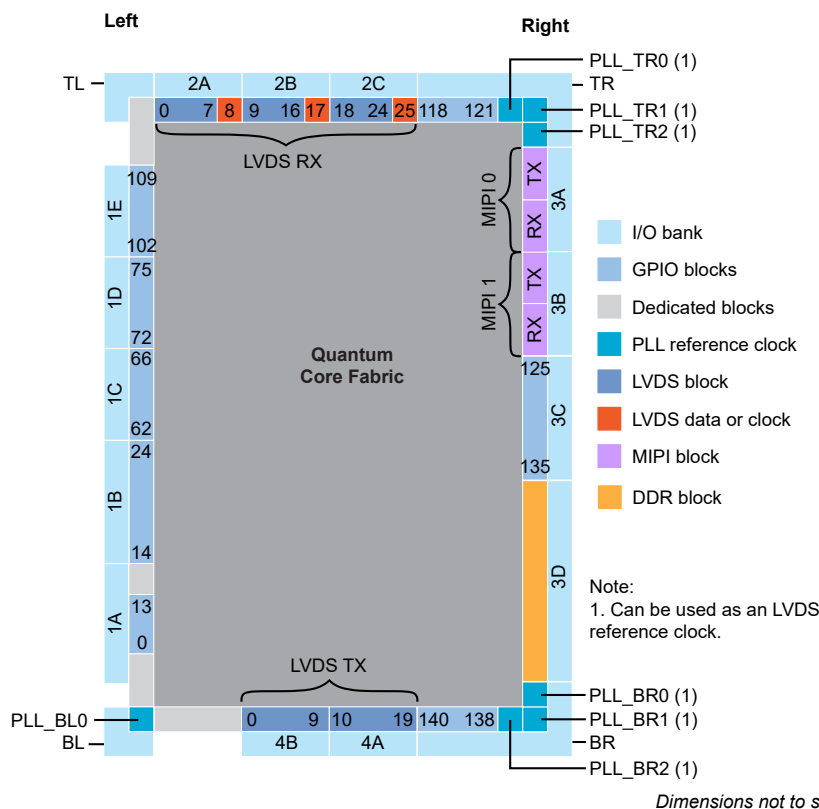
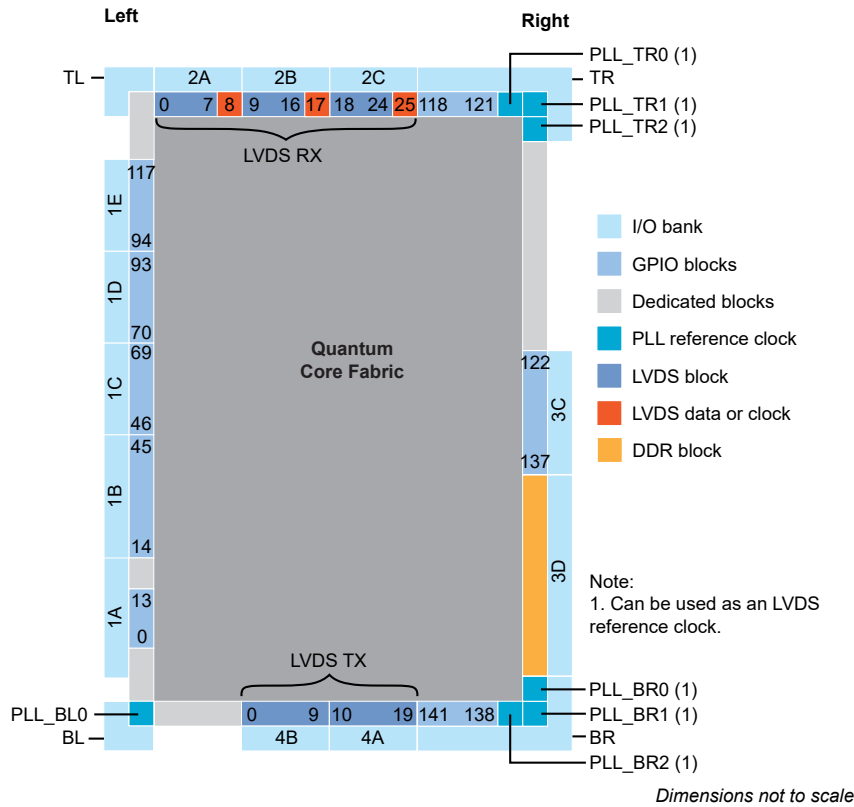

Figure 34: Floorplan Diagram for BGA400 Packages (with DDR)



## Ordering Codes

Refer to the [Trion Selector Guide](#) for the full listing of T35 ordering codes.

# Revision History

Table 97: Revision History

Date	Version	Description
November 2021	2.0	<p>Added storage temperature, <math>T_{STG}</math> spec. (DOC-560)</p> <p>Updated maximum JTAG mode TCK frequency, <math>f_{TCK}</math>. (DOC-574)</p> <p>Updated CSI pin description. (DOC-546)</p> <p>Updated LVDS Pins Configured as Single-Ended I/O Buffer Drive Strength specifications. (DOC-578)</p> <p>Update LVDS standard compliance which is TIA/EIA-644. (DOC-592)</p> <p>Updated <math>t_{CLKH}</math> and <math>t_{CLKL}</math>, and corrected SPI Passive Mode (x1) Timing Sequence waveform. (DOC-590)</p> <p>Updated REF_RES_xx description. (DOC-602, DOC-605)</p> <p>Updated Maximum Toggle Rate table. (DOC-630)</p> <p>Updated minimum Power Supply Ramp Rates. (DOC-631)</p>
September 2021	1.9	<p>Added Single-Ended I/O and LVDS Pins Configured as Single-Ended I/O Rise and Fall Time specs. (DOC-522)</p> <p>Added note to Active mode configuration clock frequency stating that for parallel daisy chain x2 and x4 configuration, <math>f_{MAX\_M}</math>, must be set to DIV4. (DOC-528)</p> <p>Added Global Clock Location topic. (DOC-532)</p> <p>Added Maximum <math>t_{USER}</math> for SPI Active and Passive Modes topic. (DOC-535)</p>
August 2021	1.8	<p>Added internal weak pull-up and pull-down resistor specs. (DOC-485)</p> <p>Updated table title for Single-Ended I/O Schmitt Trigger Buffer Characteristic. (DOC-507)</p> <p>Added note in Pinout Description stating all dedicated configuration pins have Schmitt Trigger buffer. (DOC-507)</p>
June 2021	1.7	Updated CRESET_N pin description. (DOC-450)
April 2021	1.6	<p>Updated PLL specs; <math>t_{LJIT}</math> (PK - PK) and <math>t_{DT}</math>. (DOC-403)</p> <p>Added note about limiting number of LVDS as GPIO output and bidirectional per I/O bank to avoid switching noise. (DOC-411)</p>
March 2021	1.5	Added LVDS TX reference clock output duty cycle and lane-to-lane skew specs. (DOC-416)
February 2021	1.4	<p>Corrected LVDS TX Settings in Efinity® Interface Designer Output Load default value. (DOC-375)</p> <p>Updated Density parameter description and added 256Mb to choice to LPDDR2 in DDR Interface Designer Settings. (DOC-377)</p> <p>Added I/O input voltage, <math>V_{IN}</math> specification. (DOC-389)</p> <p>Added LVDS TX data and timing relationship waveform. (DOC-359)</p> <p>Added LVDS RX I/O electrical specification waveform. (DOC-346)</p>

Date	Version	Description
December 2020	1.3	<p>Updated the notes for Output Load parameter in LVDS TX Settings in Efinity Interface Designer. (DOC-309)</p> <p>Added data for C4L and I4L DC speed grades. (DOC-268)</p> <p>Added a table to Power Up Sequence topic describing pin connection when PLL, GPIO, MIPI, or DDR is not used. (DOC-325)</p> <p>Updated NSTATUS pin description. (DOC-335)</p> <p>Updated PLL reference clock input note by asking reader to refer to PLL Timing and AC Characteristics. (DOC-336)</p> <p>Added other PLL input clock frequency sources in PLL Timing and AC Characteristics. (DOC-336)</p> <p>Removed OE and RST from LVDS block as they are not supported in software. (DOC-328)</p> <p>For the DDR reference clock, the software issues a warning (instead of error) if you do not connect the reference clock to an I/O pad. (DOC-264)</p>
September 2020	1.2	<p>Updated pinout links.</p> <p>Corrected speed grades for single-ended I/O and LVDS configured as single-ended I/O <math>f_{MAX}</math>.</p>
August 2020	1.1	<p>Update MIPI TX and RX Interface Block Diagram to include signal names.</p> <p>Updated REF_CLK description for clarity.</p> <p>Updated <math>t_{USER}</math> timing parameter values and added a note about the conditions for the values.</p> <p>Correct the VDDIO_DDR to VCCIO_DDR.</p> <p>Updated description for GPIO pins state during configuration to exclude LVDS as GPIO.</p> <p>Added <math>f_{MAX}</math> for single-ended I/O and LVDS configured as single-ended I/O.</p> <p>Added maximum power supply current transient during power-up.</p> <p>Correct the VDDIO_DDR to VCCIO_DDR.</p>
July 2020	1.0	<p>Removed preliminary note from DC and switching characteristics, LVDS I/O electrical specifications, MIPI electrical specifications and timing, PLL timing and AC characteristics, and configuration timing. These specifications are final.</p> <p>Added VDDIO_DDR absolute maximum ratings.</p> <p>Added VDDIO_DDR for DDR3, DDR3L, LPDDR3, and LPDDR2 recommended operating conditions.</p> <p>Updated timing parameter symbols in boundary scan timing waveform to reflect JTAG mode parameter symbols.</p> <p>Added supported GPIO features.</p> <p>Updated the maximum <math>F_{VCO}</math> for PLL to 1,600 MHz.</p> <p>Updated the C divider requirement for the 90 degrees phase shift in the PLL Interface Designer Settings - Manual Configuration Tab.</p> <p>Updated the DDR DRAM reset signal from RST_N to CFG_RST_N.</p> <p>Corrected DDR DRAM block diagram by adding DDR_CK signal.</p> <p>Updated minimum setup time for passive configuration mode to 6.5ns.</p> <p>Updated I/O bank names from TL_CORNER, BL_CORNER, TR_CORNER, and BR_CORNER to TL, BL, TR, and BR respectively.</p> <p>Updated LVDS electrical specifications note about RX differential I/O standard support, and duplicated the note in LVDS functional description topic.</p> <p>Added note to LVDS RX interface block diagram.</p> <p>Removed all instances of DDR3U.</p>

Date	Version	Description
July 2020	1.0	<p>Added note to recommended power-up sequence about MIPI power guideline.</p> <p>Updated the term DSP to multiplier.</p> <p>Updated power up sequence description about holding CRESET_N low.</p> <p>Updated floorplan diagram for FPGAs in BGA324 and BGA400 Packages.</p> <p>Added I/O bank information for BGA400 package.</p> <p>Updated PLLCLK pin name to PLL_CLKIN.</p> <p>Added PLL_EXTFB and MIPI_CLKIN as an alternative input in GPIO signals table for complex I/O buffer.</p> <p>Added PLL reference clock resource assignments for BGA400 package.</p> <p>Updated Memory CAS Latency (CL) choices in Advanced Options tab - Memory Mode register settings subtab.</p> <p>Updated Output Drive Strength choices for LPDDR2 in Advanced Options tab - Memory Mode register settings subtab.</p> <p>Corrected Enable Target 1 parameter notes in AXI 0 and AXI 1 tabs.</p> <p>Removed restriction on CLKOUT1 and CLKOUT2 when CLKIN is used to drive the DDR on CLKOUT0 in DDR DRAM PHY signals table.</p> <p>Added note stating that low core leakage current (6.7 mA typical) is applicable to BGA256 package only.</p> <p>Updated available GPIO, global clocks from GPIO pins, and global controls from GPIO pins for BGA400 package.</p>
February 2020	0.3	<p>Added JTAG timing specifications.</p> <p>In MIPI RX and TX interface description, updated maximum data pixels for RAW10 data type.</p> <p>Added MIPI reset timing information.</p> <p>Added Trion power-up sequence. MIPI power-up moved to this topic.</p> <p>VCC12A_MIPI_TX, VCC12A_MIPI_RX maximum recommended operating condition changed to 1.25 V.</p> <p>Added a note to the Supported Configuration Modes topic to clarify that T35 BGA324 FPGAs do not support multi-image configuration in SPI active x1 mode.</p> <p>Added the maximum PLL output clock speed for PLL BR0 CLKOUT0 (DDR PHY input clock).</p> <p>Corrected the read and write signal directions in the DDR block diagram.</p> <p>Corrected write strobe bus width.</p> <p>Added number of global clocks and controls that can come from GPIO pins to package resources table.</p>
December 2019	0.2	<p>Updated DDR block description.</p> <p>Updated PLL Interface Designer settings.</p> <p>Removed MIPI data type bit settings. Refer to AN 015: Designing with the Trion MIPI Interface for the bit settings.</p> <p>Removed DIV1 and DIV2 active mode configuration frequencies; they are not supported.</p> <p>Added note to LVDS electrical specifications about RX differential I/O standard support.</p>
November 2019	0.1	Initial release.

## Looking for pricing, stock, or lifecycle information?

Click below to explore more details on WIN SOURCE:

 [View T35F32414 on WIN SOURCE](#)

 [Efinix, Inc. Information](#)

## Optimize Your Supply Chain with WIN SOURCE Solutions

-  Global Sourcing Solution
-  Obsolete Management
-  Cost Control Management
-  Shortage Management
-  Alternative Solution
-  Excess Inventory Management