

# MGA-43024

## 2.4 GHz WLAN Power Amplifier Module



### Data Sheet

#### Description

Avago Technologies' MGA-43024 is a fully matched power amplifier for use in the WLAN band (2401- 2484 MHz). High linear output power at 5.0 V is achieved through the use of Avago's proprietary 0.25  $\mu\text{m}$  GaAs Enhancement-mode pHEMT process. MGA-43024 is housed in a miniature 5.0 mm  $\times$  5.0 mm molded-chip-on-board (MCOB) module package. A detector is also included on-chip. The compact footprint coupled with high gain, high linearity and good efficiency makes the MGA-43024 an ideal choice as a power amplifier for small cell enterprise WLAN PA applications.

#### Component Image

##### (5.0 $\times$ 5.0 $\times$ 0.82) mm Package Outline

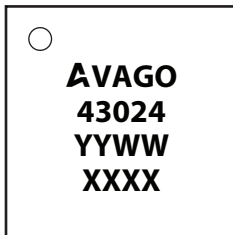

TOP VIEW

Notes:  
 Package marking provides orientation and identification  
 "43024" = Device part number  
 "YYWW" = Year and work week  
 "XXXX" = Assembly lot number

#### Features

- Linear  $P_{out}$  @ EVM =2.5% (802.11n): 27.8 dBm
- Linear  $P_{out}$  with Restricted Band Emission (802.11n) of -48 dBm @ 2412 MHz: 22.2 dBm
- Linear  $P_{out}$  with Restricted Band Emission (802.11n) of -48 dBm @ 2462 MHz: 22.2 dBm
- High gain : 40.5 dB
- Fully matched input and output ports
- Built-in detector
- GaAs E-pHEMT Technology [1]
- Low-cost small package size: (5.0  $\times$  5.0  $\times$  0.82) mm
- MSL3
- Lead-free/Halogen-free/RoHS compliance

Note:

1. Enhancement mode technology employs positive  $V_{GS}$ , and so eliminates the need for negative gate voltage associated with conventional depletion mode devices.

#### Applications

- Enterprise WLAN access points
- Small cell with embedded WLAN

#### Pin Configuration

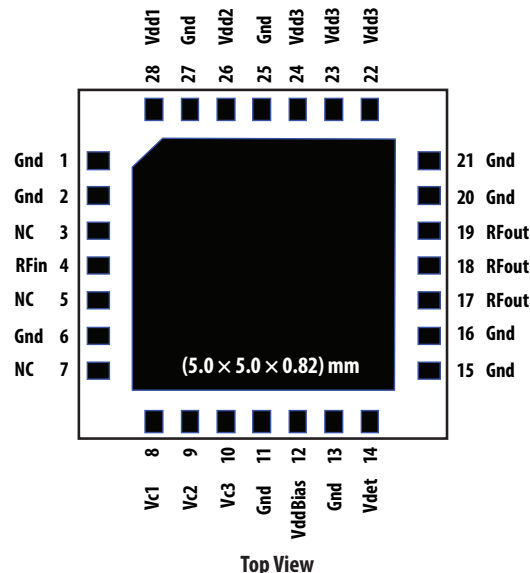

**Attention: Observe precautions for handling electrostatic-sensitive devices.**  
 ESD Machine Model = 60 V  
 ESD Human Body Model = 400 V  
 Refer to Avago Application Note A004R: *Electrostatic Discharge, Damage and Control.*

#### Functional Block Diagram

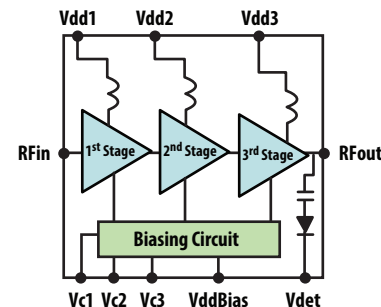

**Absolute Maximum Rating**<sup>[1]</sup>  $T_A = 25\text{ }^\circ\text{C}$ 

Symbol	Parameter	Units	Absolute Max.
$V_{dd}, V_{ddBias}$	Supply voltages, bias supply voltage	V	5.5
$V_c$	Control voltage	V	( $V_{dd}$ )
$P_{in,max}$	CW RF Input Power	dBm	20
$P_{diss}$	Total Power Dissipation <sup>[3]</sup>	W	6.0
$T_j$	Junction Temperature	$^\circ\text{C}$	150
$T_{STG}$	Storage Temperature	$^\circ\text{C}$	-65 to 150

**Thermal Resistance**<sup>[2,3]</sup>

$\theta_{JC} = 13\text{ }^\circ\text{C/W}$

Notes:

1. Operation of this device in excess of any of these limits may cause permanent damage.
2. Thermal resistance measured using Infra-Red Measurement Technique.
3. Board temperature ( $T_C$ ) is  $25\text{ }^\circ\text{C}$ , for  $T_C > 72\text{ }^\circ\text{C}$  derate the device power at 77 mW per  $^\circ\text{C}$  rise in board (package belly) temperature.

**Electrical Specifications**

$T_A = 25\text{ }^\circ\text{C}$ ,  $V_{dd} = V_{ddbias} = 5.0\text{ V}$ ,  $V_{c1} = 2.0\text{ V}$ ,  $V_{c2} = 2.2\text{ V}$ ,  $V_{c3} = 2.0\text{ V}$ , RF performance at 2442 MHz, IEEE 802.11n 64-QAM, 20 MHz Bandwidth, MCS 7, 800 ns Guard Interval, unless otherwise stated.

Symbol	Parameter and Test Condition	Units	Min.	Typ.	Max.
$V_{dd}$	Supply Voltage	V		5.0	
$I_{dq}$	Quiescent Supply Current	mA	250	480	650
$I_{ddtotal}$	Total Supply Current at linear output 21 dBm (2412 MHz)	mA	400	540	800
	Total Supply Current at linear output 21 dBm (2462 MHz)	mA	400	550	800
	Total Supply Current at linear output 27 dBm	mA		700	
S21	Small Signal Gain	dB		40.5	
S11	Input Return Loss, 50 $\Omega$ source	dB		12.5	
S22	Output Return Loss, 50 $\Omega$ source	dB		13.5	
OP1dB	Output Power at 1 dB Gain Compression	dBm		36	
PAE	Power Added Efficiency at linear output 21 dBm (2412 MHz)	%		4.4	
	Power Added Efficiency at linear output 21 dBm (2462 MHz)	%		5.2	
	Power Added Efficiency at linear output 27 dBm	%		14.8	
2fo	2nd Harmonic Distortion at 27 dBm	dBc		-34.6	
3fo	3rd Harmonic Distortion at 27 dBm	dBc		-53.3	
Linear $P_{out}$	Restricted Band Emission (RBE) @ 21 dBm at 2390 MHz (2412 MHz)	dBm		-50.5	-48
	Restricted Band Emission (RBE) @ 21 dBm at 2483.5 MHz (2462 MHz)	dBm		-50.5	-48
	Error Vector Magnitude at 2.5%	dBm		27.8	

## Product Consistency Distribution Charts [1]

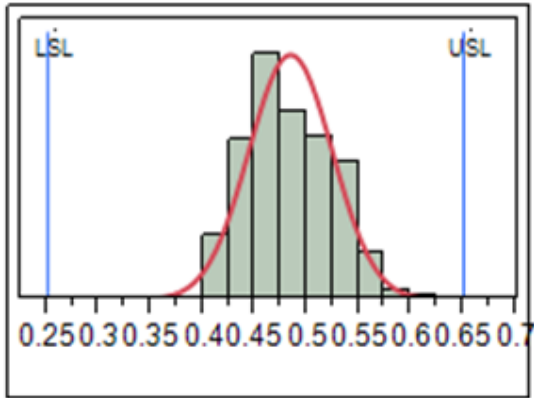

Figure 1.  $I_{dq}$

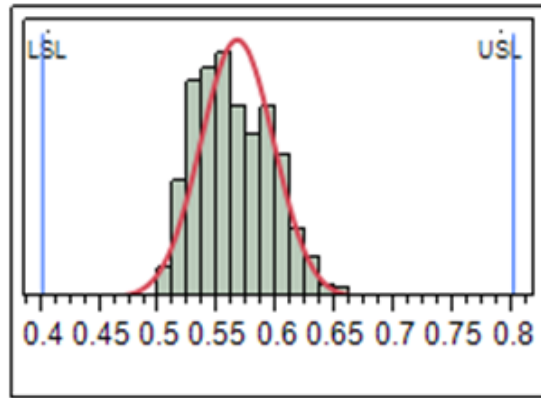

Figure 2.  $I_{dd\ total}$  @ 21 dBm at 2412 MHz

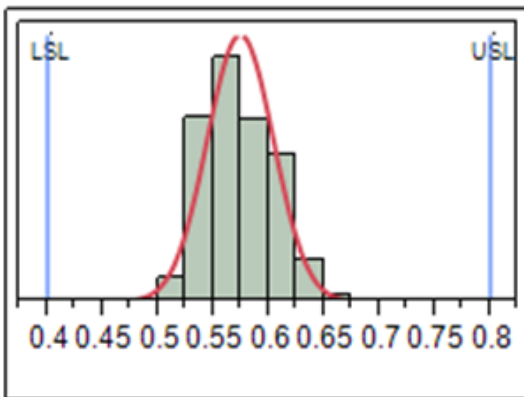

Figure 3.  $I_{dd\ total}$  @ 21 dBm at 2462 MHz

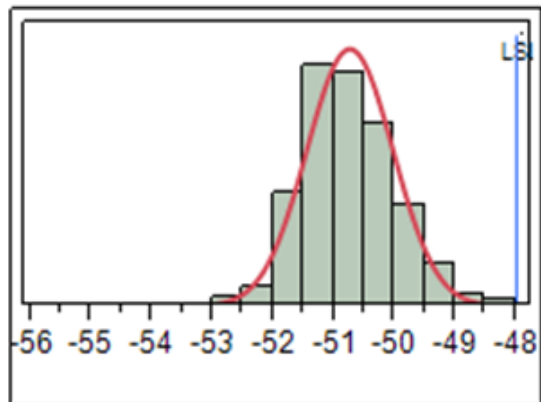

Figure 4. RBE @ 21 dBm at 2390 MHz

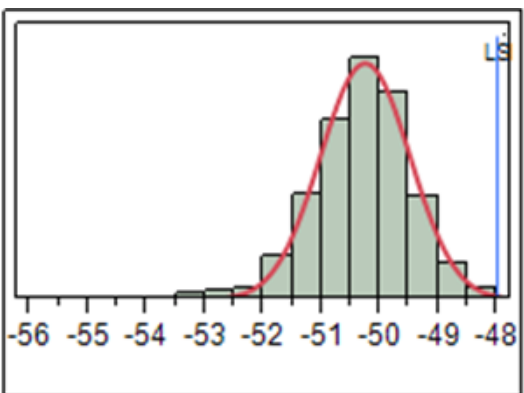

Figure 5. RBE @ 21 dBm at 2483.5 MHz

Note:

1. Distribution data sample size is 1200 samples taken from three wafer lots.  $T_A = 25^\circ\text{C}$ ,  $V_{dd} = V_{dd\text{Bias}} = 5.0\text{V}$ ,  $V_{C1} = 2.0\text{V}$ ,  $V_{C2} = 2.2\text{V}$ ,  $V_{C3} = 2.0\text{V}$ , RF input at 2412 MHz and 2462 MHz, unless otherwise stated. Future wafers allocated to this product may have nominal values anywhere between the upper and lower limits.

MGA-43024 typical small-signal over-temperature performance at  $V_{c1} = 2.0\text{ V}$ ,  $V_{c2} = 2.2\text{ V}$ ,  $V_{c3} = 2.0\text{ V}$  ( $V_{dd} = V_{ddBias} = 5.0\text{ V}$ ) as per demonstration board in Figure 28, unless otherwise stated.

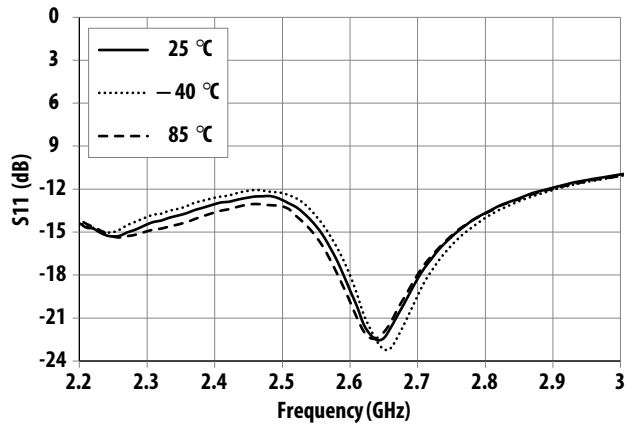

Figure 6. Over-temperature S11 vs. Frequency

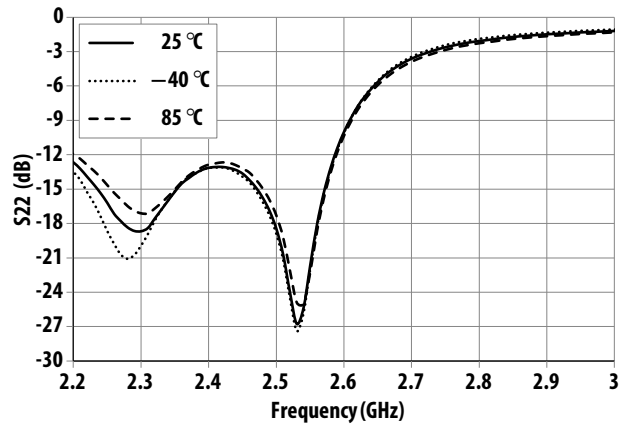

Figure 7. Over-temperature S22 vs. Frequency

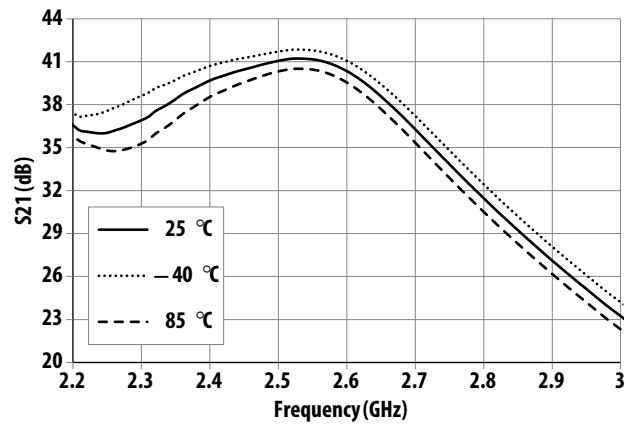

Figure 8. Over-temperature S21 vs. Frequency

MGA-43024 typical over-temperature performance at  $V_{c1} = 2.0\text{ V}$ ,  $V_{c2} = 2.2\text{ V}$ ,  $V_{c3} = 2.0\text{ V}$  ( $V_{dd} = V_{ddBias} = 5.0\text{ V}$ ) with IEEE 802.11n 64-QAM, 20 MHz Bandwidth, MCS 7, 800 ns Guard Interval as per demonstration board in Figure 28, unless otherwise stated.

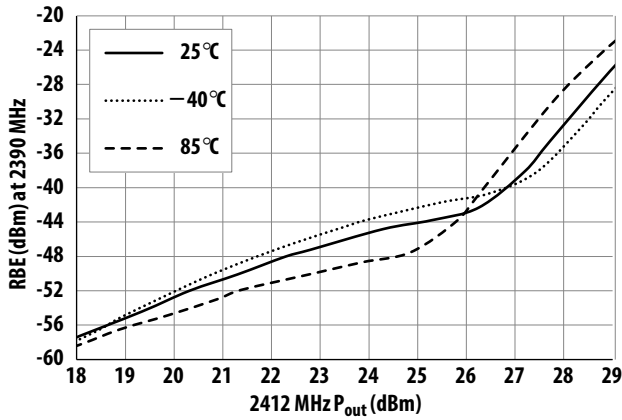

Figure 9. Over-temperature RBE at 2390 MHz vs. 2412 MHz  $P_{out}$

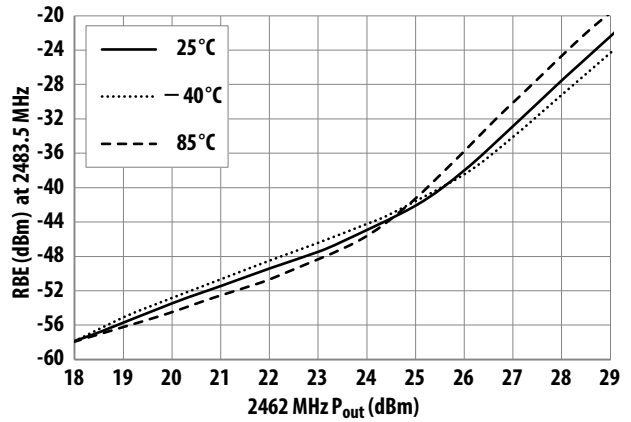

Figure 10. Over-temperature RBE at 2483.5 MHz vs. 2462 MHz  $P_{out}$

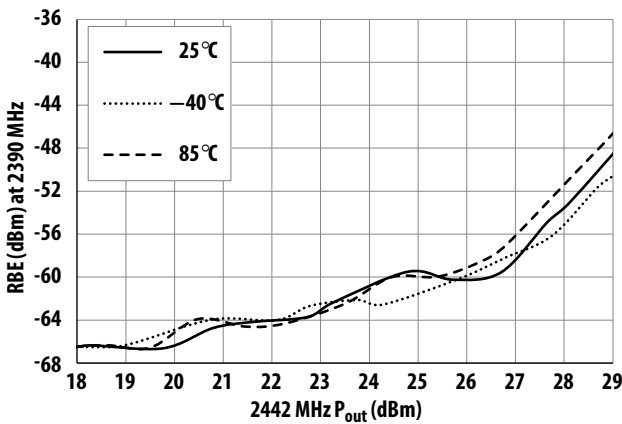

Figure 11. Over-temperature RBE at 2390 MHz vs. 2442 MHz  $P_{out}$

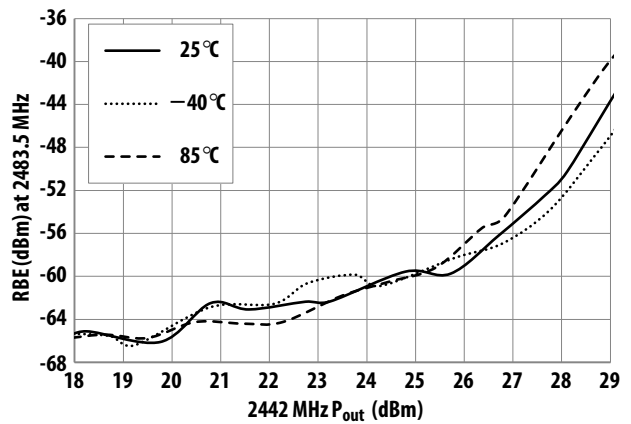

Figure 12. Over-temperature RBE at 2483.5 MHz vs. 2442 MHz  $P_{out}$

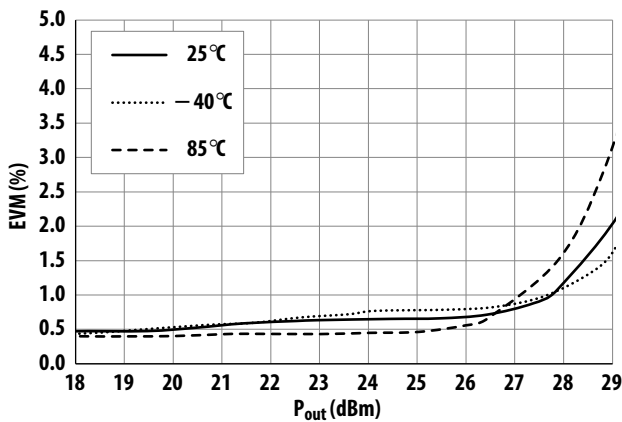

Figure 13. Over-temperature EVM vs.  $P_{out}$  at 2412 MHz

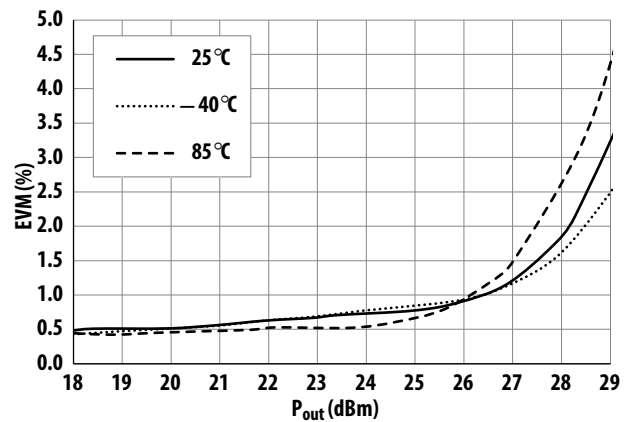

Figure 14. Over-temperature EVM vs.  $P_{out}$  at 2442 MHz

MGA-43024 typical over-temperature performance at  $V_{C1} = 2.0\text{ V}$ ,  $V_{C2} = 2.2\text{ V}$ ,  $V_{C3} = 2.0\text{ V}$  ( $V_{dd} = V_{ddBias} = 5.0\text{ V}$ ) with IEEE 802.11n 64-QAM, 20 MHz Bandwidth, MCS 7, 800 ns Guard Interval as per demonstration board in Figure 28, unless otherwise stated. (con't)

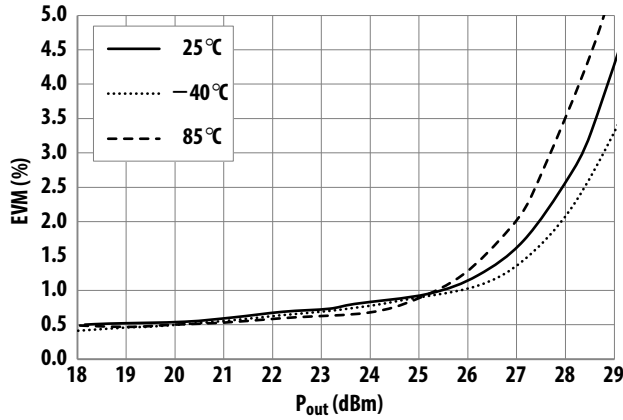

Figure 15. Over-temperature EVM vs.  $P_{out}$  at 2462 MHz

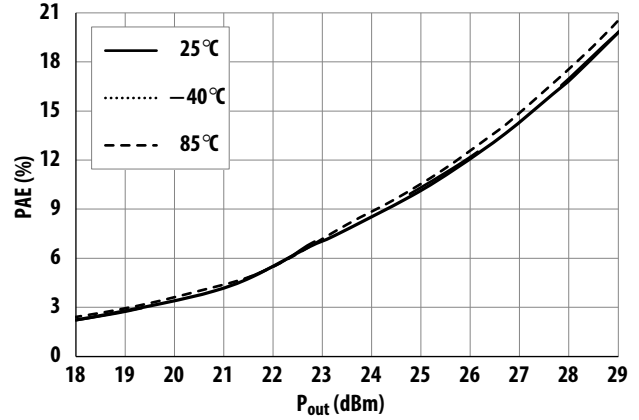

Figure 16. Over-temperature PAE vs.  $P_{out}$  at 2442 MHz

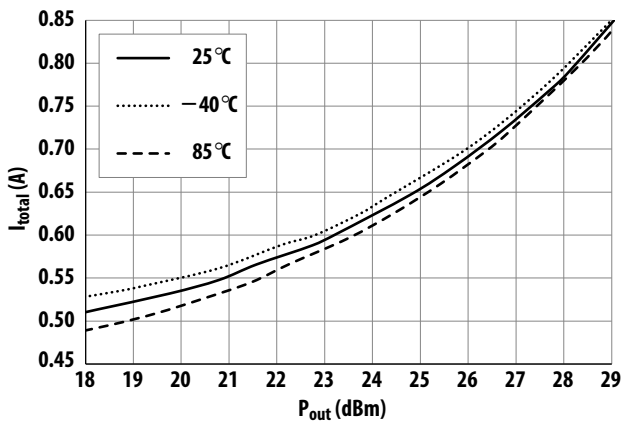

Figure 17. Over-temperature  $I_{total}$  vs.  $P_{out}$  at 2442 MHz

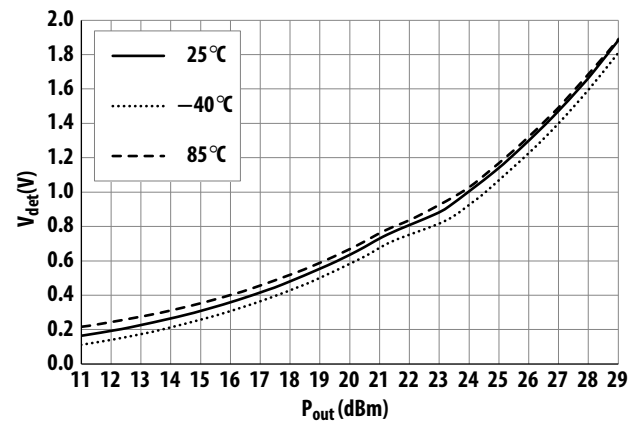

Figure 18. Over-temperature  $V_{det}$  vs.  $P_{out}$  at 2442 MHz

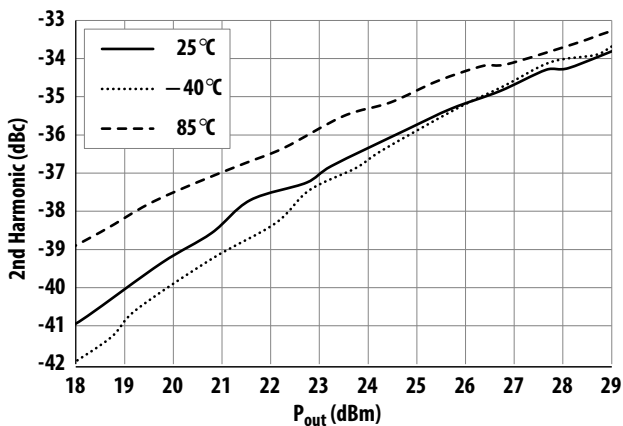

Figure 19. Over-temperature 2nd Harmonic vs.  $P_{out}$  at 2442 MHz

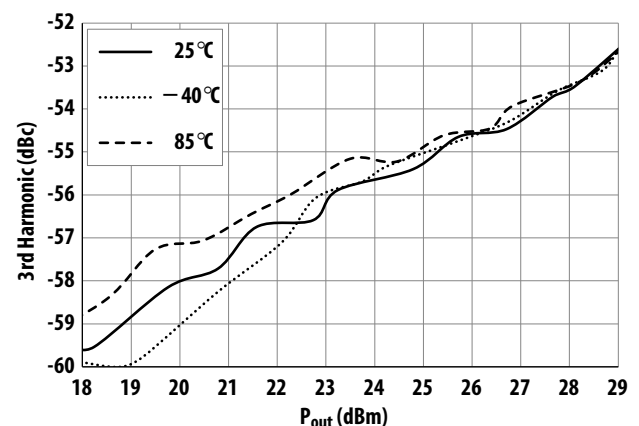

Figure 20. Over-temperature 3rd Harmonic vs.  $P_{out}$  at 2442 MHz

MGA-43024 typical over-temperature performance at  $V_{C1} = 2.0\text{ V}$ ,  $V_{C2} = 2.2\text{ V}$ ,  $V_{C3} = 2.0\text{ V}$  ( $V_{dd} = V_{ddBias} = 5.0\text{ V}$ ) with IEEE 802.11n 64-QAM, 20 MHz Bandwidth, MCS 7, 800 ns Guard Interval as per demonstration board in Figure 28, unless otherwise stated. (con't)

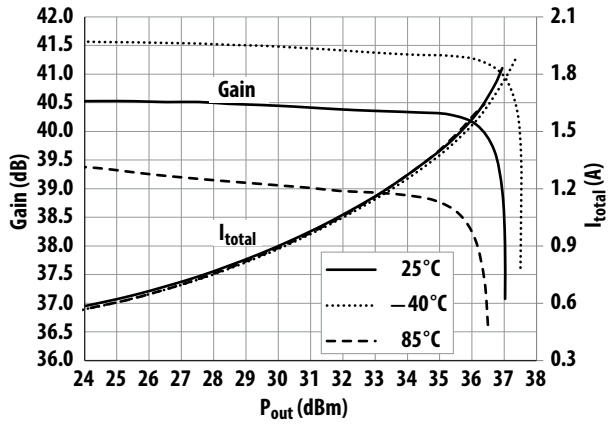

Figure 21. Over-temperature CW Gain,  $I_{total}$  vs.  $P_{out}$  at 2412 MHz

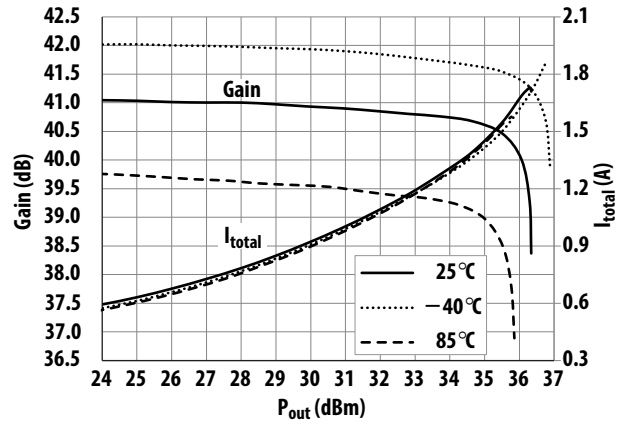

Figure 22. Over-temperature CW Gain,  $I_{total}$  vs.  $P_{out}$  at 2442 MHz

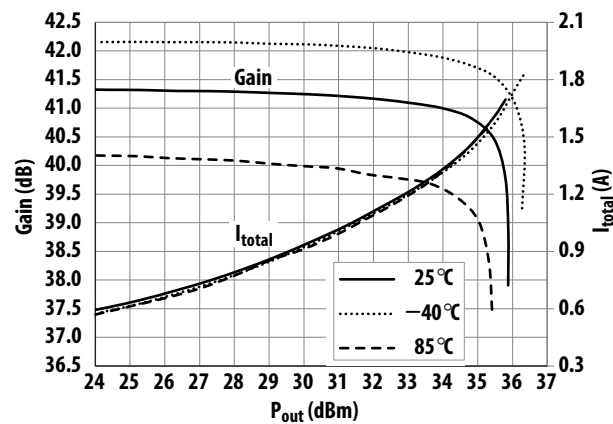

Figure 23. Over-temperature CW Gain,  $I_{total}$  vs.  $P_{out}$  at 2462 MHz

MGA-43024 typical over-temperature performance at  $V_{c1} = 2.0\text{ V}$ ,  $V_{c2} = 2.2\text{ V}$ ,  $V_{c3} = 2.0\text{ V}$  ( $V_{dd} = V_{ddBias} = 5.0\text{ V}$ ) with IEEE 802.11n 64-QAM, 20 MHz Bandwidth, MCS 7, 800 ns Guard Interval as per demonstration board in Figure 28, unless otherwise stated. (con't)

Spectrum Emission Mask (SEM) with 802.11n IEEE 20.3.21.1 signal

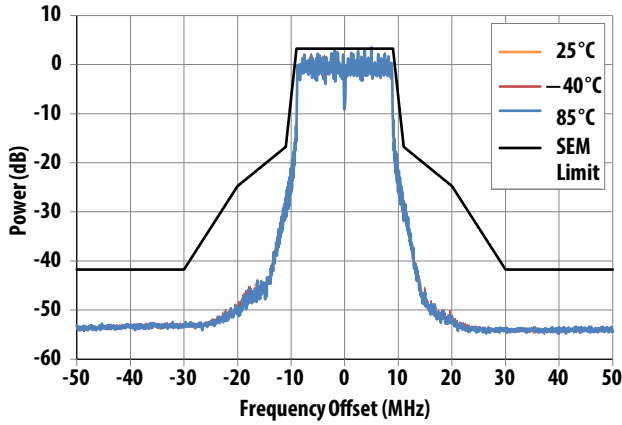

Figure 24. Over-temperature SEM 22 dBm at 2442 MHz

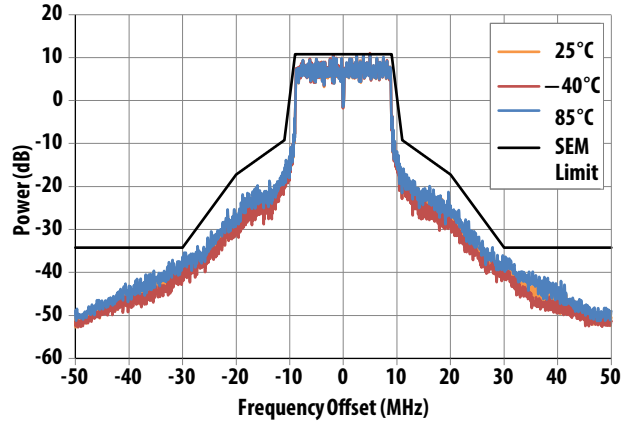

Figure 25. Over-temperature SEM 29.5 dBm at 2442 MHz

Spectrum Emission Mask (SEM) with 802.11b IEEE 18.4.7.3 signal

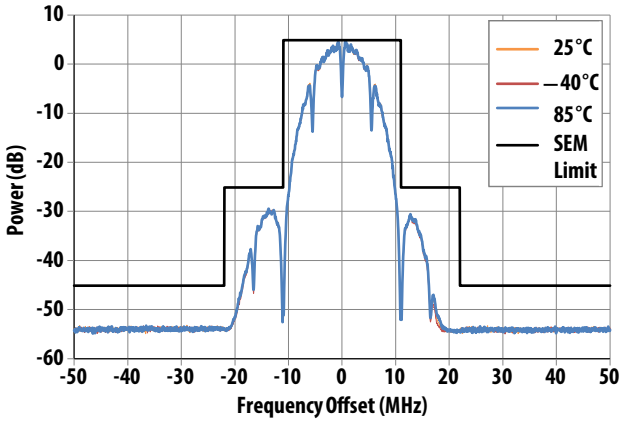

Figure 26. Over-temperature SEM 22 dBm at 2442 MHz

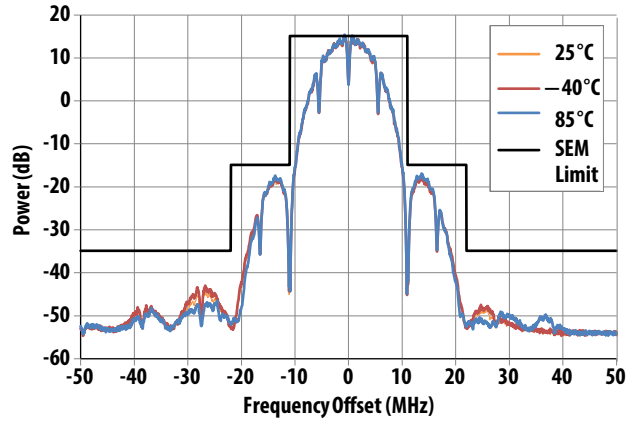

Figure 27. Over-temperature SEM 32.5 dBm at 2442 MHz

**S-Parameter<sup>[1]</sup> ( $V_{dd} = V_{ddBias} = 5.0\text{ V}$ ,  $V_{c1} = 2.0\text{ V}$ ,  $V_{c2} = 2.2\text{ V}$ ,  $V_{c3} = 2.0\text{ V}$ ),  $T = 25\text{ }^\circ\text{C}$ ,  $50\text{ }\Omega$  matched)**

Freq (GHz)	S11 (dB)	S11 (ang)	S21 (dB)	S21 (ang)	S22 (dB)	S22 (ang)	S12 (dB)	S12 (ang)
0.1	-5.43	176.76	-53.24	-88.81	-0.35	175.70	-55.49	-40.22
0.2	-5.36	173.07	-54.47	-115.45	-0.90	175.67	-68.49	173.95
0.3	-5.30	169.21	-53.63	-95.98	-0.87	176.21	-68.75	74.73
0.4	-5.29	165.81	-47.86	-74.48	-0.82	175.63	-72.13	87.45
0.5	-5.20	162.13	-34.01	-56.47	-0.79	174.68	-64.83	166.52
0.6	-5.08	158.00	-20.91	-68.36	-0.79	173.62	-68.99	126.29
0.7	-4.87	152.79	-7.81	-90.34	-0.79	172.43	-73.39	-177.74
0.8	-5.16	142.97	5.89	-147.07	-0.83	171.13	-64.77	105.00
0.9	-6.34	145.60	10.27	126.75	-0.93	170.07	-72.97	83.31
1.0	-5.89	144.39	11.56	86.97	-1.03	169.11	-67.77	105.38
1.1	-5.65	139.58	14.46	57.00	-1.17	168.08	-73.61	-150.63
1.2	-5.46	134.64	17.86	28.58	-1.29	167.77	-66.13	72.40
1.3	-5.39	128.40	21.93	-10.53	-1.33	168.28	-64.35	50.60
1.4	-5.76	121.38	24.07	-63.05	-1.08	168.89	-61.70	49.67
1.5	-6.23	117.87	20.76	-118.28	-0.61	166.91	-66.18	86.15
1.6	-6.11	111.71	10.72	-109.65	-0.31	161.86	-67.45	97.68
1.7	-7.19	102.91	23.12	-64.44	-0.56	156.24	-65.86	49.22
1.8	-7.10	95.38	25.31	-93.41	-0.63	149.63	-68.46	123.55
1.9	-7.97	80.76	32.19	-122.72	-1.57	140.08	-58.51	132.79
2.0	-10.91	58.32	36.61	-168.72	-3.66	131.53	-55.78	120.35
2.1	-19.36	44.90	38.41	136.31	-6.80	137.06	-52.15	89.68
2.2	-19.46	138.15	35.98	94.50	-8.67	141.81	-52.13	70.07
2.3	-15.29	106.72	35.86	78.48	-11.34	169.74	-52.58	63.29
2.4	-16.07	79.03	39.34	46.47	-8.73	175.99	-51.07	41.07
2.5	-19.02	-25.52	41.45	-7.88	-16.09	-170.53	-50.49	27.04
2.6	-11.83	-140.97	39.25	-73.99	-4.92	-118.16	-52.22	-12.46
2.7	-10.24	175.54	33.98	-117.30	-1.66	-141.22	-55.28	-20.79
2.8	-10.21	155.09	29.17	-144.19	-0.83	-153.69	-59.07	-30.68
2.9	-10.50	142.75	25.03	-164.15	-0.51	-161.35	-61.28	-12.99
3.0	-10.85	134.44	21.39	179.45	-0.34	-166.63	-66.56	-20.94
3.1	-11.16	128.08	18.08	165.18	-0.24	-170.63	-68.65	-7.15
3.2	-11.41	122.97	15.01	152.30	-0.17	-173.96	-65.97	-30.47
3.3	-11.61	118.30	12.08	140.39	-0.12	-176.87	-68.77	-34.57
3.4	-11.79	114.24	9.23	129.41	-0.09	-179.41	-69.24	10.34
3.5	-11.92	110.58	6.41	119.09	-0.06	178.23	-73.82	-47.03
3.6	-12.02	107.96	3.54	109.20	-0.05	175.97	-71.58	43.92
3.7	-11.95	105.87	0.51	99.81	-0.03	173.81	-69.40	74.30
3.8	-11.79	104.01	-2.86	91.20	-0.02	171.81	-66.46	62.70
3.9	-11.59	102.15	-6.85	83.86	-0.02	169.83	-69.21	67.60
4.0	-11.37	100.63	-12.19	80.44	-0.02	167.90	-62.92	47.56
4.1	-11.11	99.47	-20.71	98.79	-0.02	166.01	-67.18	65.14
4.2	-10.84	98.82	-20.34	-179.04	-0.02	164.11	-61.86	82.30
4.3	-10.52	99.14	-14.53	-169.00	-0.03	162.24	-64.22	80.70
4.4	-10.14	100.31	-12.21	-175.37	-0.05	160.41	-61.42	79.01
4.5	-9.52	102.50	-12.70	-177.29	-0.07	158.59	-60.52	56.17
4.6	-8.44	104.22	-10.56	-139.72	-0.11	156.86	-58.52	56.27
4.7	-7.06	101.06	-1.32	-155.54	-0.16	155.25	-59.69	45.05
4.8	-6.43	94.30	1.80	157.65	-0.20	153.90	-56.95	47.96
4.9	-6.34	89.68	1.32	119.72	-0.21	152.60	-58.92	37.03

**S-Parameter<sup>[1]</sup> ( $V_{dd} = V_{ddBias} = 5.0\text{ V}$ ,  $V_{c1} = 2.0\text{ V}$ ,  $V_{c2} = 2.2\text{ V}$ ,  $V_{c3} = 2.0\text{ V}$ ),  $T = 25\text{ }^{\circ}\text{C}$ ,  $50\text{ }\Omega$  matched) Cont.**

Freq (GHz)	S11 (dB)	S11 (ang)	S21 (dB)	S21 (ang)	S12 (dB)	S12 (ang)	S22 (dB)	S22 (ang)
5.0	-6.46	84.78	0.01	91.18	-0.24	150.52	-57.02	31.45
5.1	-6.73	78.15	-0.92	64.62	-0.40	147.89	-59.25	12.01
5.2	-6.87	75.34	-3.06	26.21	-0.67	149.19	-59.19	-1.47
5.3	-6.97	73.43	-8.98	10.15	-0.27	149.16	-61.61	-8.22
5.4	-7.01	71.86	-12.49	8.76	-0.13	147.46	-63.56	33.91
5.5	-7.02	70.64	-15.48	9.71	-0.09	145.99	-62.32	16.46
5.6	-6.92	69.17	-15.79	16.32	-0.06	144.68	-64.11	23.62
5.7	-6.95	67.36	-16.37	1.87	-0.06	143.65	-60.01	26.24
5.8	-7.00	66.22	-18.23	-9.42	-0.05	142.77	-64.55	26.16
5.9	-7.02	65.33	-20.18	-18.10	-0.05	142.10	-62.06	39.12
6.0	-7.04	64.70	-22.19	-25.92	-0.05	141.39	-64.07	20.28
7.0	-7.02	67.98	-25.42	-139.56	-0.71	133.74	-60.95	18.91
8.0	-7.10	74.86	-29.95	64.65	-0.08	136.09	-59.44	31.23
9.0	-7.35	64.12	-30.03	14.20	-0.18	123.59	-57.11	12.30
10.0	-6.24	33.51	-32.37	-65.33	-0.29	100.34	-56.33	-22.67
11.0	-4.45	6.37	-49.16	-55.29	-0.20	85.95	-55.76	-29.37
12.0	-3.45	-1.48	-49.07	-34.30	-0.23	81.24	-57.11	-42.33
13.0	-3.45	9.38	-41.39	-24.76	-0.46	69.86	-53.63	-41.20
14.0	-4.03	18.70	-37.15	-67.28	-0.73	42.96	-52.80	-55.23
15.0	-4.82	-2.73	-35.90	-113.87	-0.92	12.09	-49.03	-74.36
16.0	-3.40	-50.29	-38.66	-156.16	-1.00	-4.11	-50.08	-90.29
17.0	-1.90	-72.72	-42.82	-178.79	-0.80	-16.68	-49.14	-91.89
18.0	-0.81	-71.96	-41.39	174.87	-0.91	-30.32	-46.04	-120.41
19.0	-0.93	-71.17	-40.04	149.88	-1.23	-51.45	-44.49	-140.30
20.0	-3.72	-130.45	-34.88	83.86	-1.11	-81.36	-42.00	165.62

Note:

1. S-parameter is measured with de-embedded reference plane at DUT RF<sub>in</sub> and RF<sub>out</sub> pins.

## Test system setup

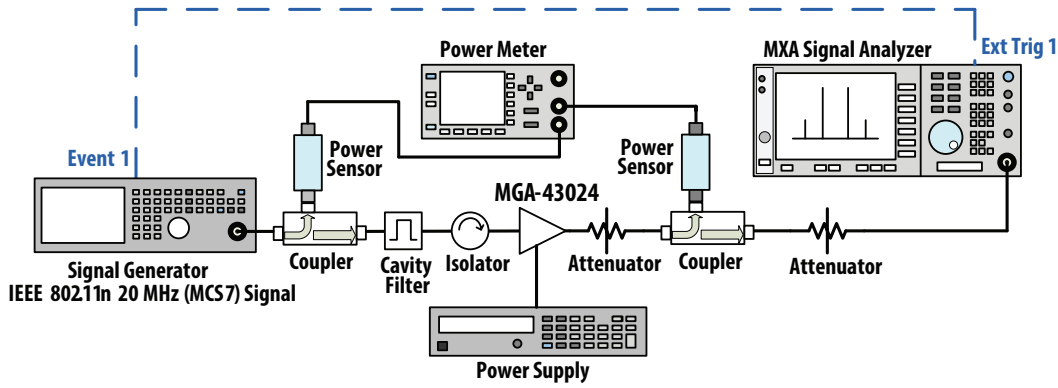

## Small-signal performance for Cavity Filter

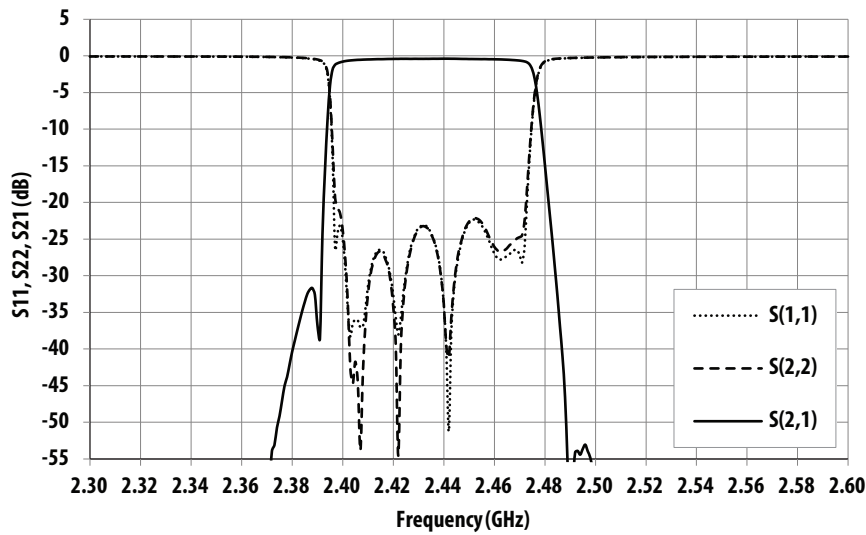

freq	S(1,1)		S(2,1)		S(2,2)		S(1,2)	
GHz	dB	ang	dB	ang	dB	ang	dB	ang
2.390	-0.58	-175.75	-36.69	-65.14	-0.51	-160.17	-36.71	-65.23
2.412	-27.89	-33.65	-0.47	64.22	-28.34	-29.88	-0.47	64.23
2.442	-51.25	159.37	-0.38	-160.42	-41.16	46.82	-0.38	-160.46
2.462	-27.81	-116.14	-0.48	41.94	-26.75	15.58	-0.48	41.97
2.483	-0.49	170.59	-25.27	86.43	-0.45	170.12	-25.33	86.26

A cavity filter is used at the input of the DUT to ensure that a clean signal from the signal generator is presented to the DUT.

# Demonstration Board Top View

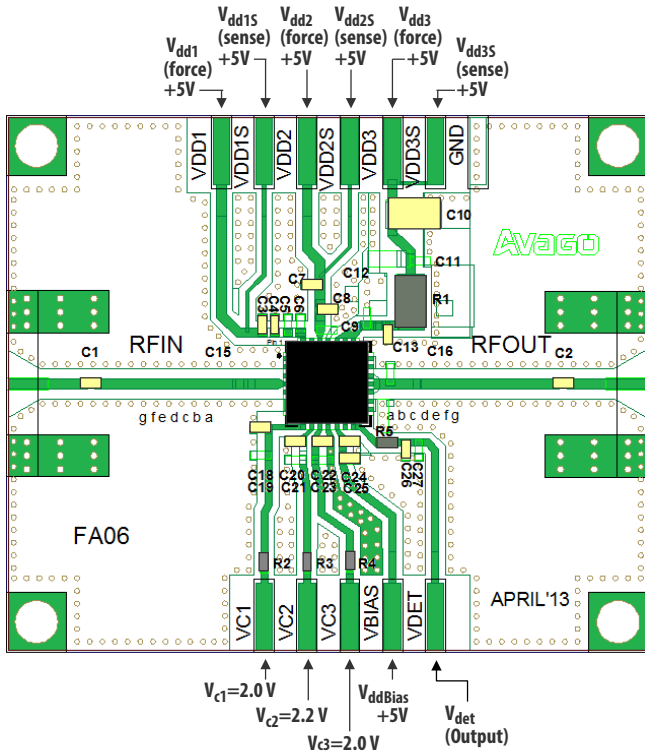

Component	Value	Part Number	Manufacturer	Size
C1, C2, C18, C20, C22	7.5 pF	GJM1555C1H7R5BB01D	Murata	0402
C3, C7, C13, C25	0.1 μF	GRM155R71C104KA88D	Murata	0402
C4, C8	8.2 pF	GRM1555C1H8R2DZ01E	Murata	0402
C10	2.2 μF	GRM21BR71E225KA73L	Murata	0805
C24	6.0 pF	GJM1555C1H6R0CB01D	Murata	0402
C26	22 nF	CM05X7R223K16AHF	AVX	0402
R1	0 Ω	RMC1/10 JPTP	Kamaya	0805
R2, R3, R4, R5	0 Ω	RMC1/16S JPTH	Kamaya	0402

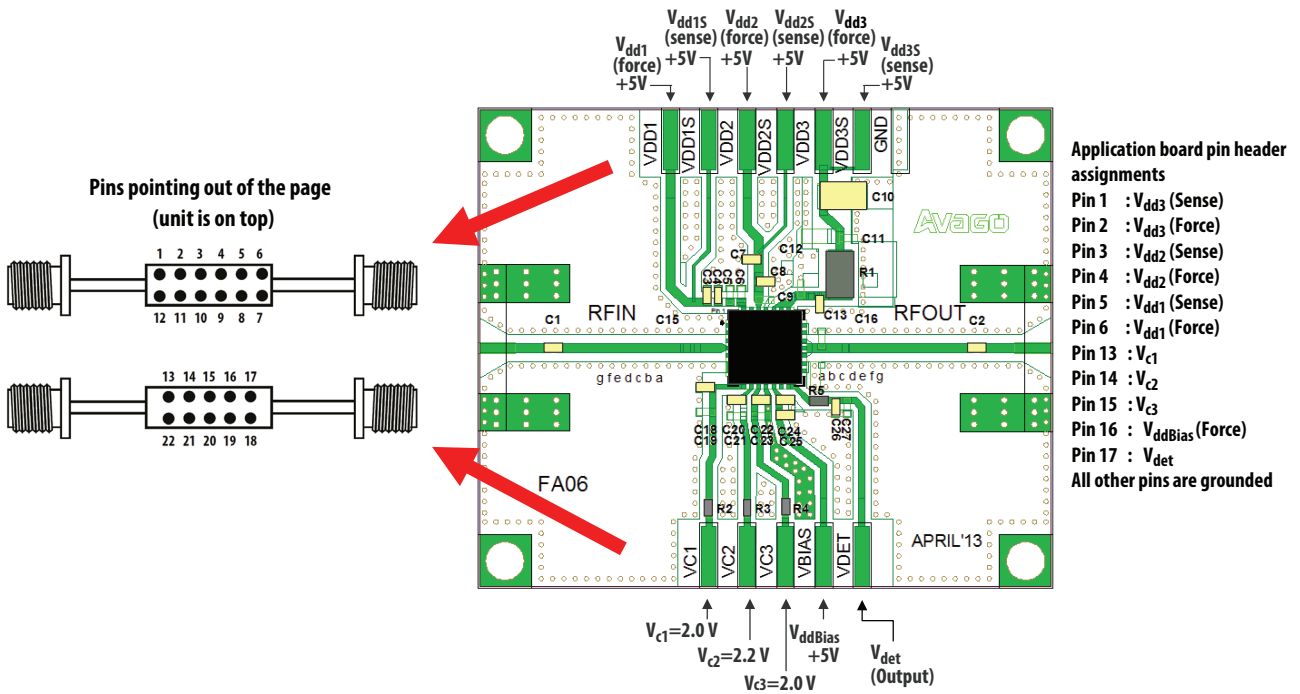

Figure 28. Demonstration board application circuit for MGA-43024 module

## Application Schematic

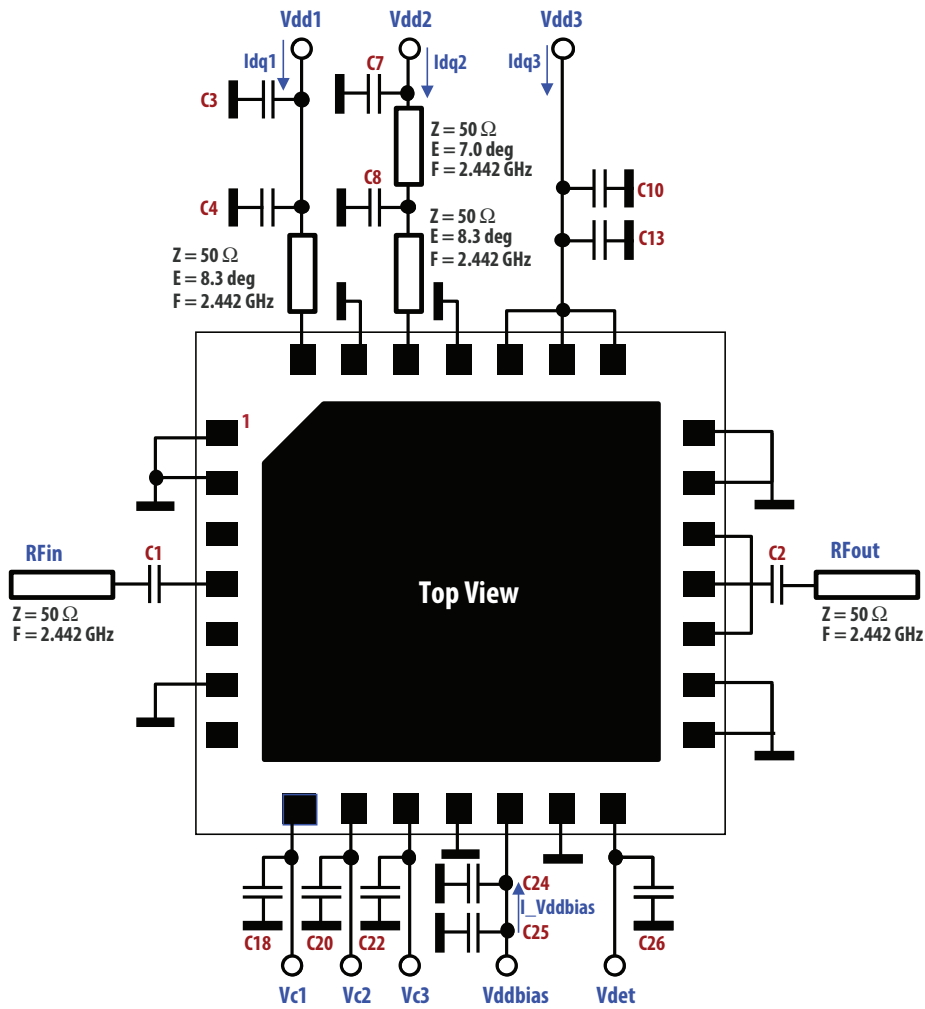
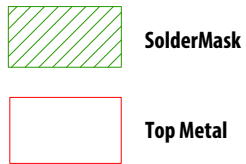
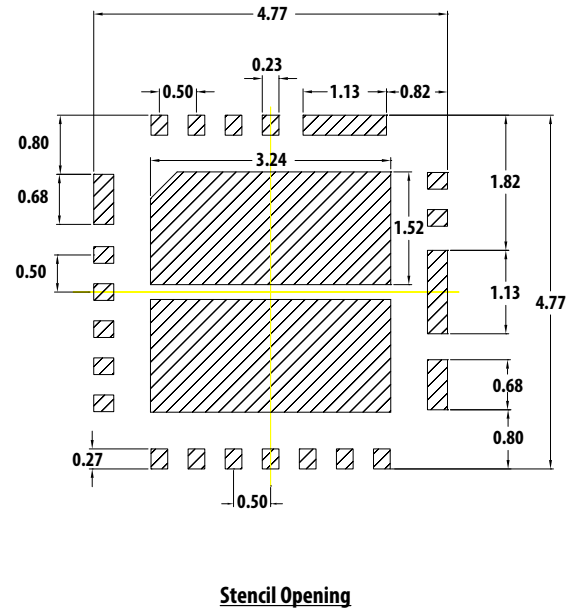
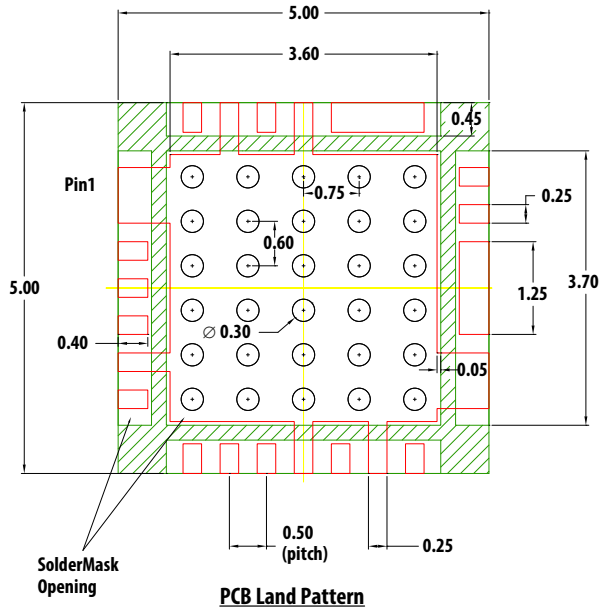

Figure 29. Application circuit in demonstration board

Notes:

1. All capacitors on supply lines are bypass capacitors.
2. C1/C2 are RF coupling capacitors.
3. For  $V_{dd} = V_{ddBias} = 5.0$  V,  $I_{dq1} = 50$  mA,  $I_{dq2} = 150$  mA,  $I_{dq3} = 248$  mA,  $I_{VddBias} = 12$  mA. These currents enable optimum bias conditions to be achieved for best linearity for 802.11n signal.

## PCB Land Pattern and Stencil Outline



### Notes:

1. Recommended Land Pattern and Stencil.
2. 4 mils stencil thickness recommended.
3. All dimensions are in mm.

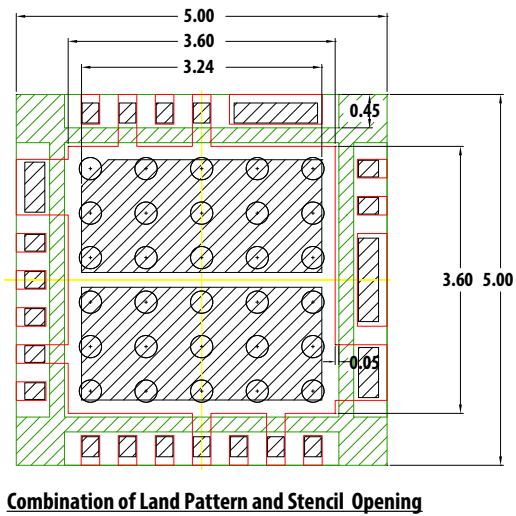

## MCOB (5.0 x 5.0 x 0.82) mm 28-Lead Package Dimensions

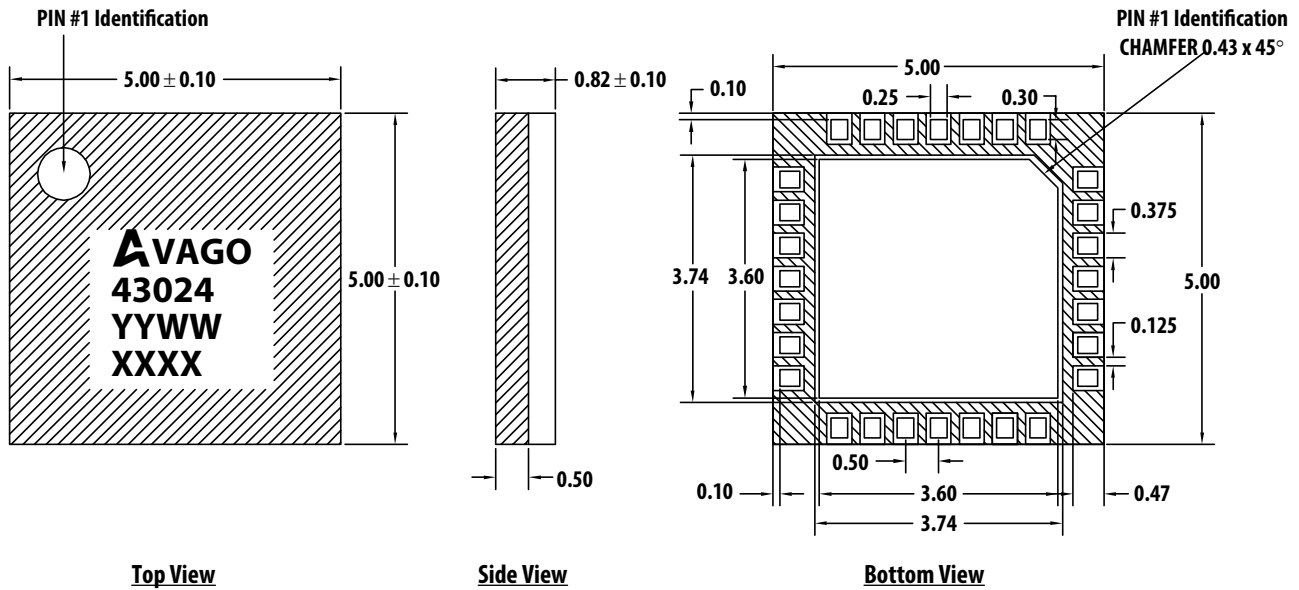

Notes:

1. All dimensions are in millimeters.
2. Dimensions are inclusive of plating.
3. Dimensions are exclusive of mold flash and metal burr.

### Part Number Ordering Information

Part Number	Qty	Container
MGA-43024-BLKG	100	Antistatic Bag
MGA-43024-TR1G	1000	7" Reel

### Device Orientation

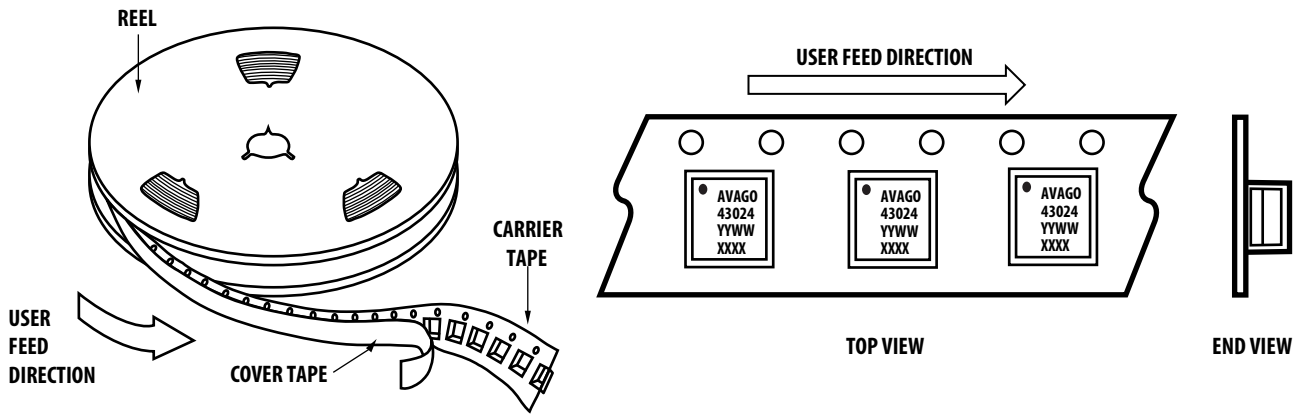

### Tape Dimensions

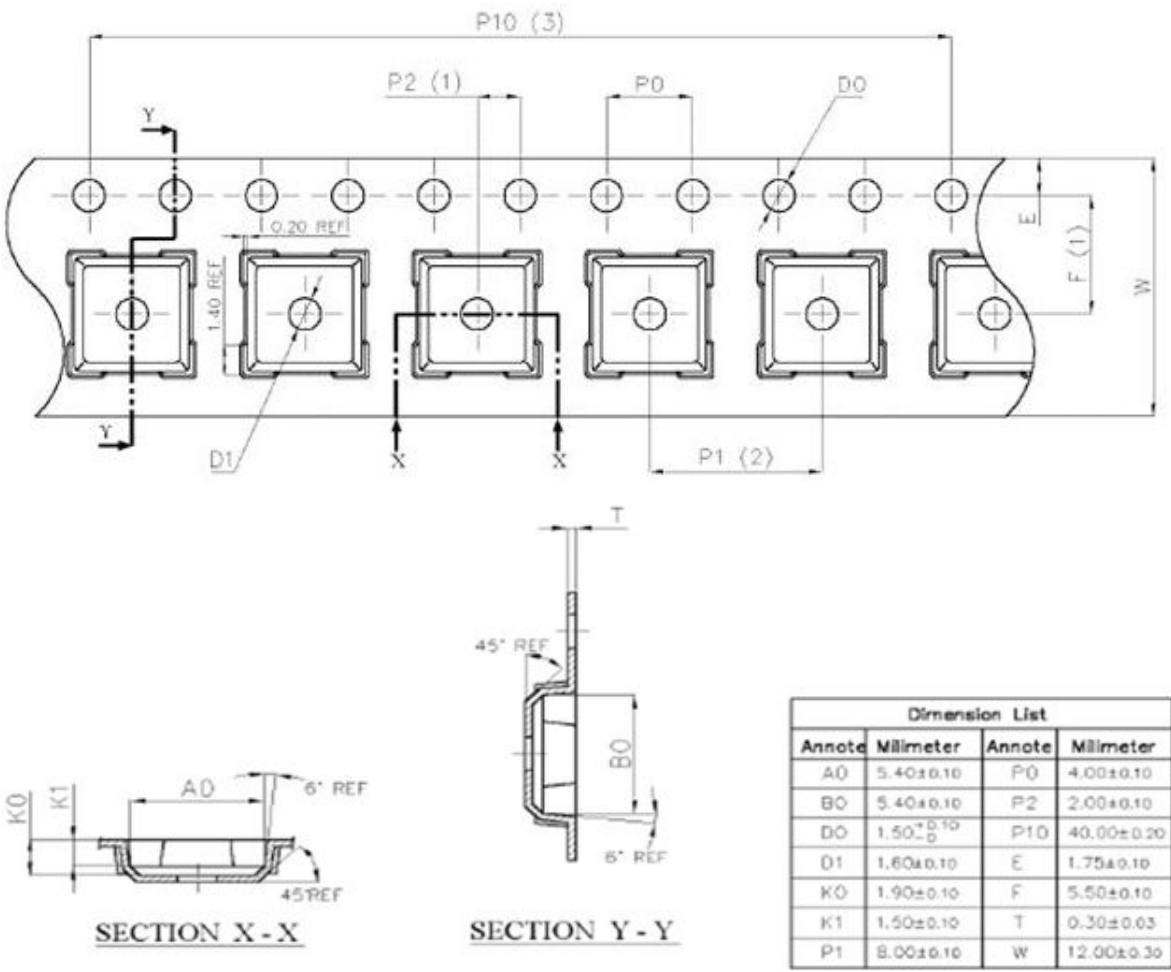

# Reel Dimensions (7" reel)

Flange Thickness : Min. 1.20 mm

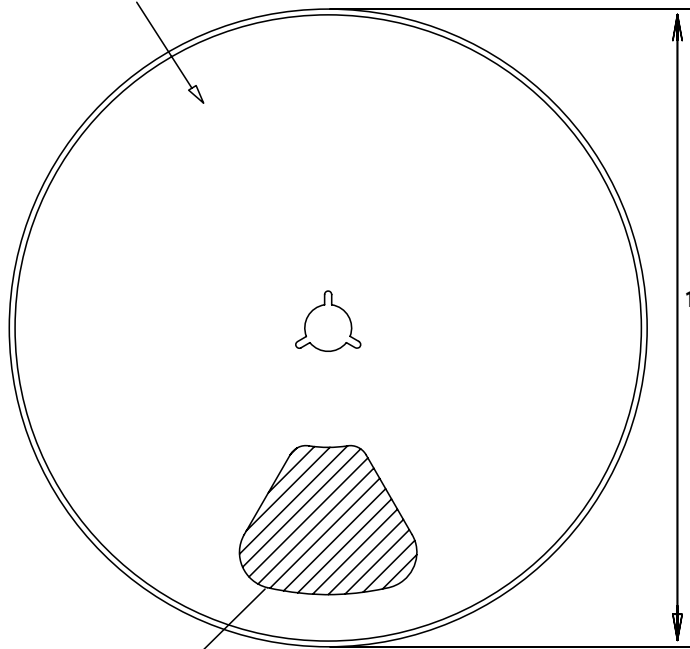

Hatched Area Indicates Thru Hole

**FRONT VIEW**

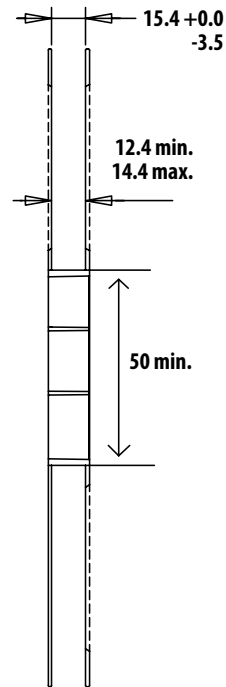

Note: Dimensions are in mm.

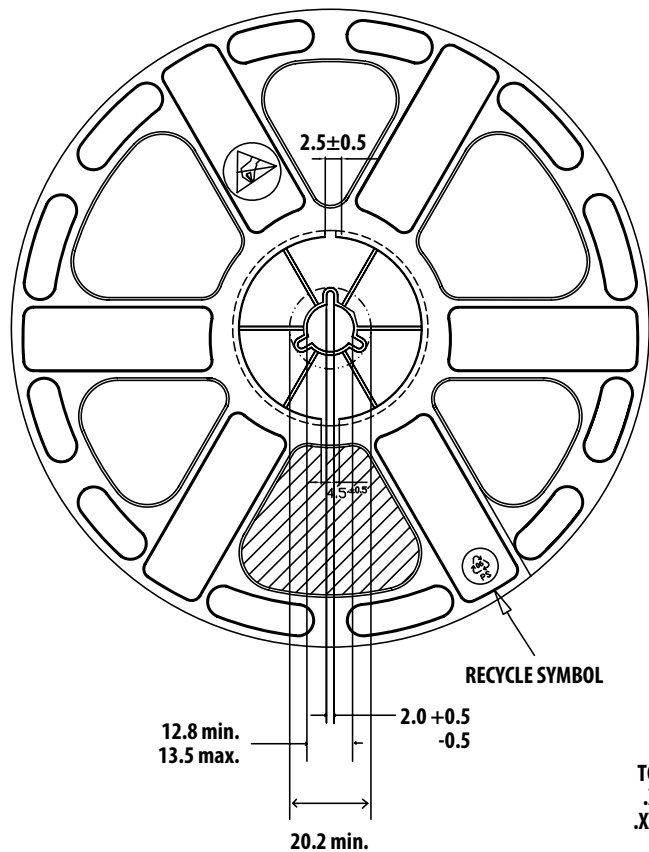

RECYCLE SYMBOL

TOLERANCE  
.X =  $\pm 0.25$   
.XX =  $\pm 0.13$

**BACK VIEW**



For product information and a complete list of distributors, please go to our web site: [www.avagotech.com](http://www.avagotech.com)

Avago, Avago Technologies, and the A logo are trademarks of Avago Technologies in the United States and other countries.  
Data subject to change. Copyright © 2005-2014 Avago Technologies. All rights reserved.  
AV02-4664EN - October 8, 2014



## Looking for pricing, stock, or lifecycle information?

Click below to explore more details on WIN SOURCE:

-  [View MGA-43024-BLKG on WIN SOURCE](#)
-  [Broadcom Limited Information](#)

## Optimize Your Supply Chain with WIN SOURCE Solutions

-  Global Sourcing Solution
-  Obsolete Management
-  Cost Control Management
-  Shortage Management
-  Alternative Solution
-  Excess Inventory Management