

Product Overview

The QPL1812 is a high performance pHEMT MMIC amplifier designed to run from a single 8V supply, without the need for an external dropping resistor. The high gain, high linearity, and low distortion from 50MHz to 1800MHz make this part ideal for broad-band cable applications. An integrated active bias circuit provides stable gain over temperature and process variations. It is offered in a small SOT-89 package and is RoHS compliant.



Package: SOT-89

Functional Block Diagram

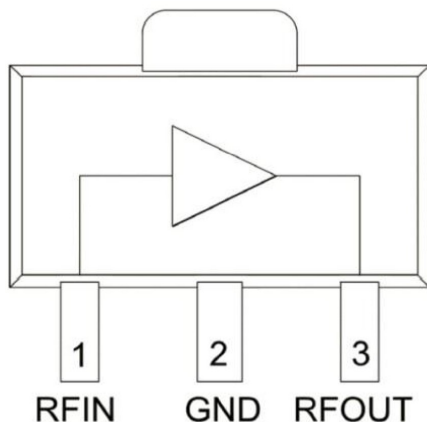

Key Features

- 8V Single Supply
- Excellent Linearity
- High Gain > 19dB
- Available in Lead-free, RoHS Compliant, and Green Packaging
- 50MHz to 1800MHz operation supporting DOCSIS 4.0
- Low Noise: \approx 4dB

Ordering Information

Part Number	Description
QPL1812SB	Sample bag with 5 pieces
QPL1812SR	7" Reel with 100 pieces
QPL1812TR13	13" Reel with 2500 pieces
QPL1812EVB-01	Evaluation Board

Applications

- Pre-Amplifier for CATV Line Amplifier
- DOCSIS 4.0
- 75 Ohm Distribution Amplifiers
- Broadband CATV Hybrid modules



Absolute Maximum Ratings

Parameter	Rating	Unit
Device Voltage (V_{DD})	10	Volts
Device Current (I_{DD})	250	mA
Maximum RF Input Power	10	dBm
Maximum Junction Temperature	+160	°C
Storage Temperature	-40 to +85	°C

Exceeding any one or a combination of the Absolute Maximum Rating conditions may cause permanent damage to the device. Extended application of Absolute Maximum Rating conditions to the device may reduce device reliability.

Electrical Specifications

Parameter	Condition ⁽¹⁾	Min	Typ	Max	Unit
Supply Voltage (V_{DD})		7.5	8	8.5	Volts
Supply Current (I_{DD})			180		mA
Frequency Range		50		1800	MHz
Gain	At 50MHz		19		dB
	At 1200MHz		19		dB
	At 1800MHz		20		dB
Gain Slope			1		dB
Reverse Isolation			24		dB
Input Return Loss			16		dB
Output Return Loss			16		dB
Noise Figure	At 1200MHz		3.5		dB
MER ⁽²⁾ At +58 dBmV Total Composite Output power	At 111MHz		42		dB
	At 1302MHz		42		dB
	At 1698MHz		41		dB
OIP2	At 50MHz		62		dBm
	At 1200MHz		63		dBm
	At 1800MHz		62		dBm
OIP3	At 50MHz		41		dBm
	At 1200MHz		39		dBm
	At 1800MHz		38		dBm
Output P1dB			21		dBm
Thermal Resistance			40		°C/W

1. Typical performance at these conditions: Temp = +25°C, VDD = +8V, 75Ω system, Full band unless otherwise noted

2. 111MHz to 1791MHz, 0dB tilt, 149 Ch.+ 4 OFDM Ch. CCN Noise BW (ANSI/SCTE 17): 5.36MHz for J.83/B. Tx Data: ITU-T, Annex B, QAM256, 5.36 MSymbols/s

Evaluation Board Schematic 50 -1800MHz

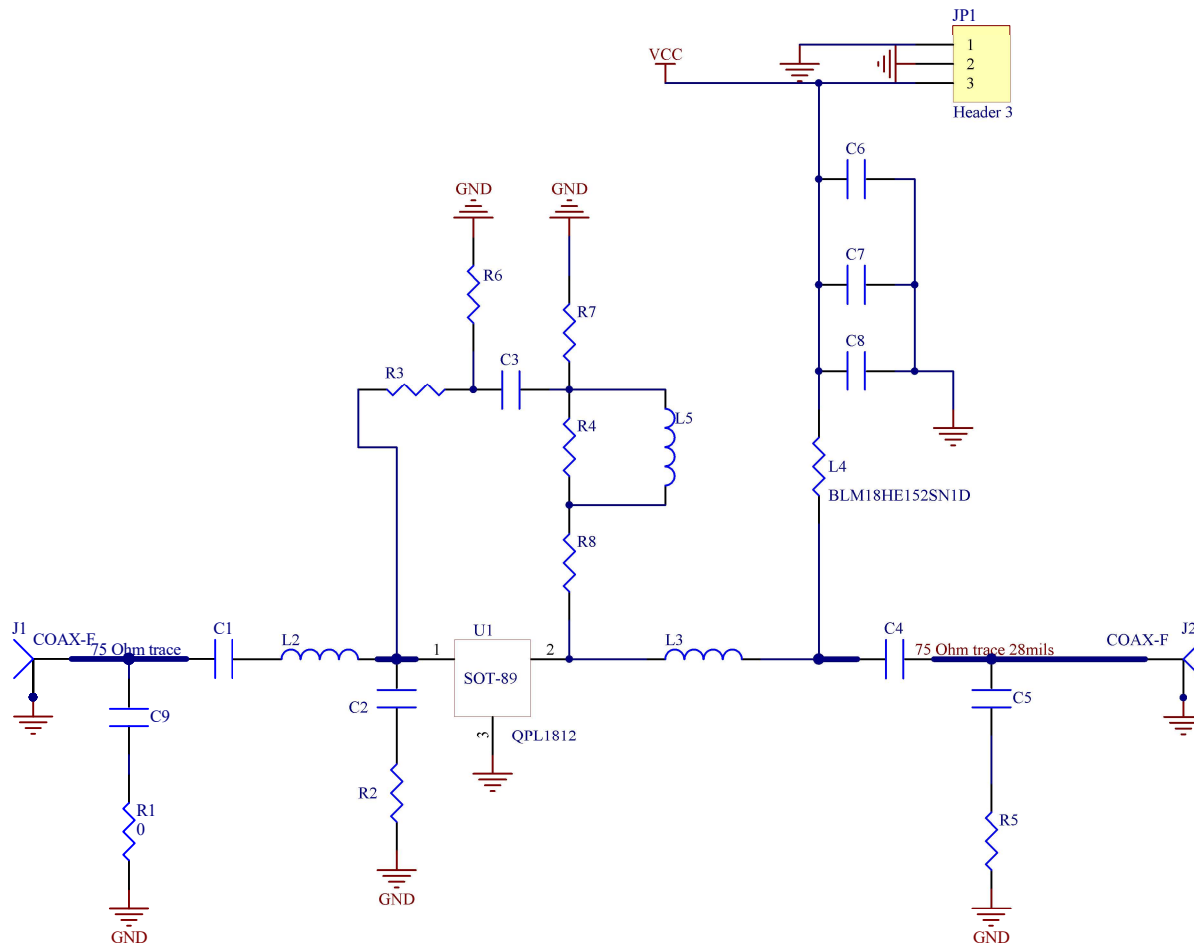

Evaluation Board Bill of Material

Ref Des	Qty	Description	Manufacturer	Manufacturer Part #
U1	1	47 to 1800MHz, 19 dB Gain, Single Ended CATV Amplifier	Qorvo	QPL1812
PCB	1	PCB, QPL1812	TTM TECHNOLOGIES INC	QPL1812-4000
C7	1	CAP, 1000pF, 10%, 50V, X8R, 0402	TDK SINGAPORE (PTE) LTD	C1005X8R1H102K050BA
C8	1	CAP, 100pF, 5%, 50V, COG, 0603	AVX Asia Limited	06035A101JAT2A
C1, C4	2	CAP, 220pF, 5%, 50V, COG, 0402	AVX Corporation	04025A221JAT2A
C5	1	CAP, 0.7pF, ±0.05pF, 200V, HI-Q, 0402	American Technical Ceramics	600L0R7AT200T
C6	1	CAP, 1uF, 10%, 50V, X5R, 0603	AVX Asia Limited	06035D105KAT2A
C3	1	CAP, 10pF, 5%, 50V, COG, 0402	Kemet	C0402T100J5GALTU
C9	1	CAP, 0.3pF, ±0.01pF, 100V, HI-Q, 0402	AVX Corporation	04021J0R3ZBSTR
R8	1	RES 0402, 1.2KOHM, 1%, 1/10W, SMD	PANASONIC CORP OF NORTH AMERICA	ERJ-2RKF1201X
R3	1	RES, 150 OHM, 5%, 1/16W, 0402	Kamaya, Inc	RMC1/16S-151JTH
R7	1	RES, 510 OHM, 5%, 1/16W, 0402	Panasonic Industrial Devices Sales	ERJ-2GEJ511
R1, R5	2	Res, 0R, 0402, 0.04W, Chip	Vishay Americas Inc	M32159B11M
R6	1	Res, 8.2K, +/-1%, 0402, 1/10W	Panasonic Industrial Devices Sales	ERJ-2RKF8201X
L2,L3	2	IND, 2.2nH, +/-0.2nH, W/W, 0402	MURATA ELECTRONICS SINGAPORE PTE LT	LQW15AN2N2C10D
L5	1	Ind, 18nH, 5% 0402	MURATA ELECTRONICS SINGAPORE PTE LT	LQW15AN18NJ00D
L4	1	FER, BEAD, 1500 OHM, 500mA, 0603	MURATA ELECTRONICS SINGAPORE PTE LT	BLM18HE152SN1D
JP1	1	CONN, HDR, ST, 3-PIN, 0.100"	SAMTEC INC.	TSW-103-07-G-S
J1, J2	2	CONN, F, EDGE MOUNT, 60 MIL	Trompeter Electronics, Inc.	CBJE130-1
C2, R2, R4	3	NOT POPULATED ITEMS	Not applicable	Not applicable

Evaluation Board Layout 50 -1800MHz

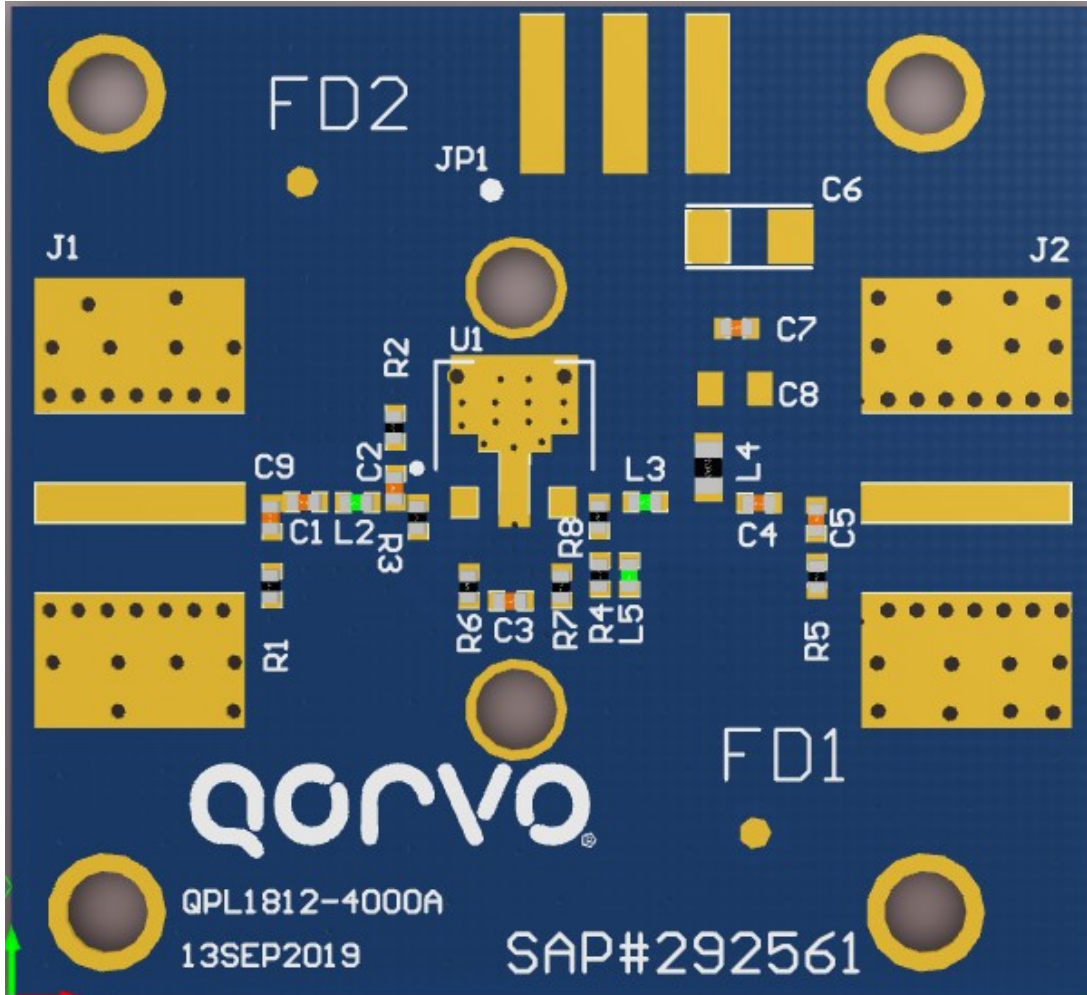

Evaluation Board PCB Material and Stack-up

2 Layer FR4 Board, 1.3inches X 1.2inches

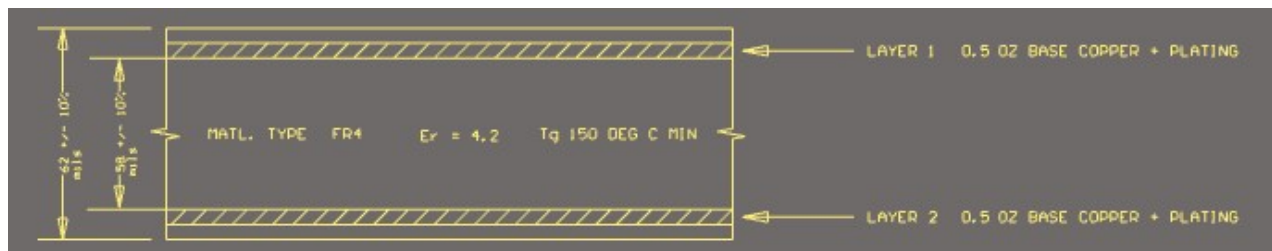

Performance Data

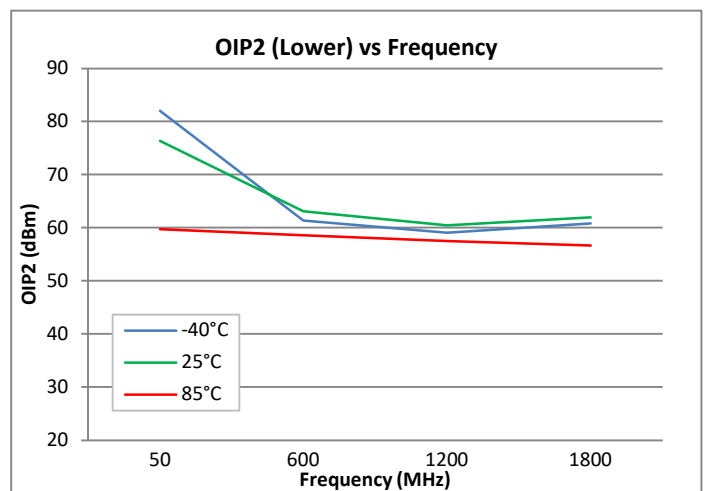
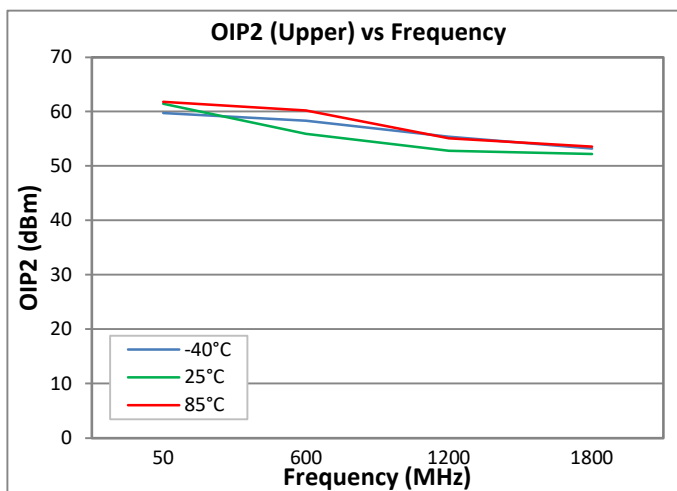
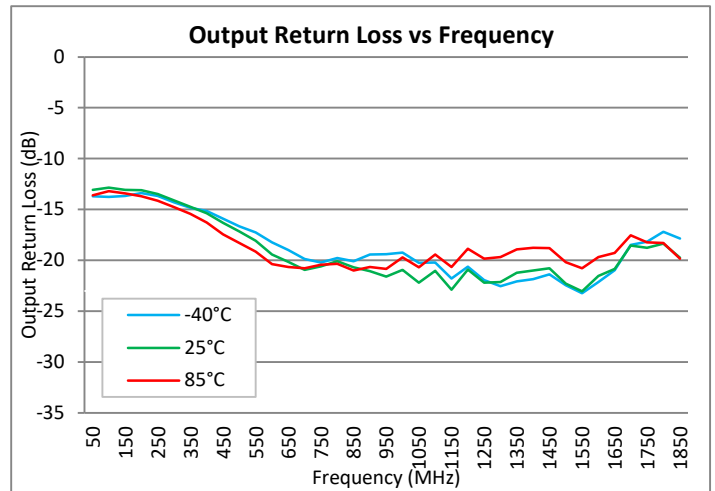
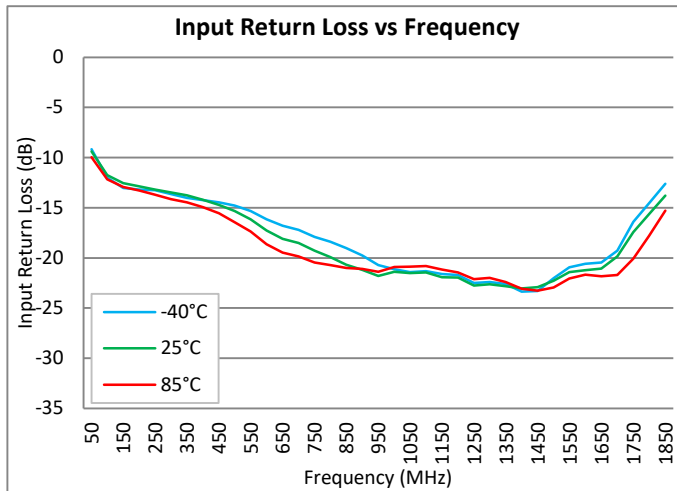
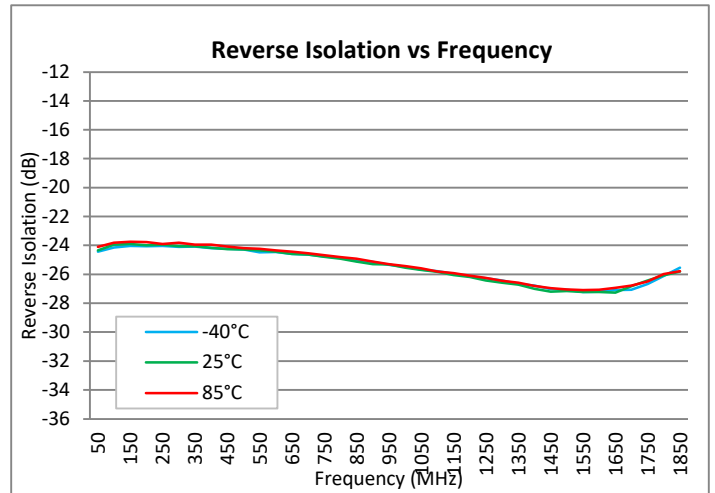
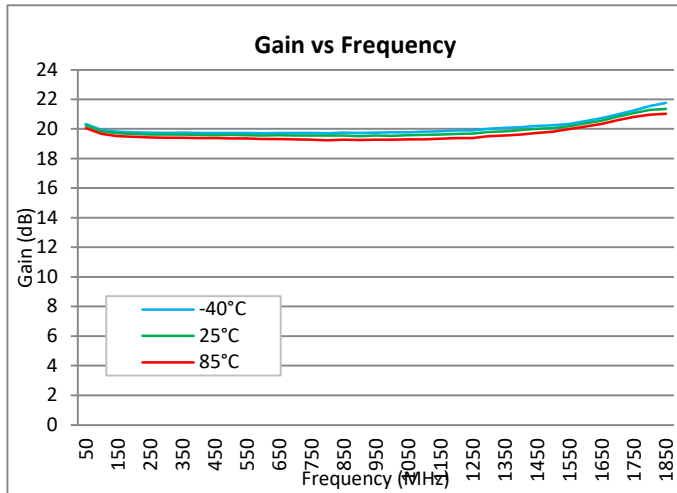

Performance Data

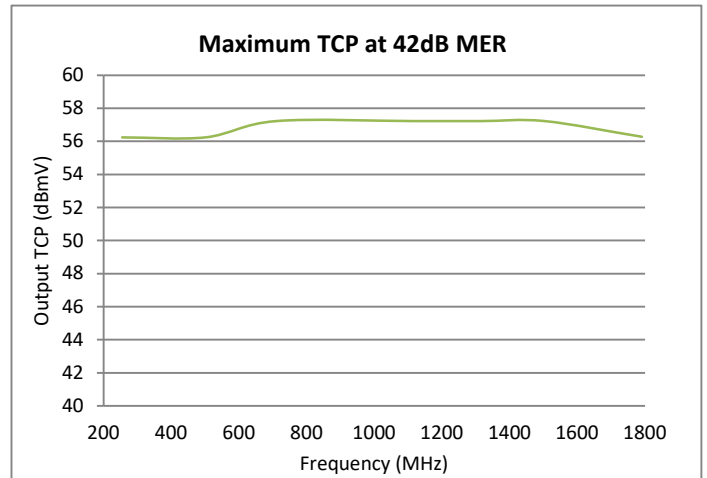
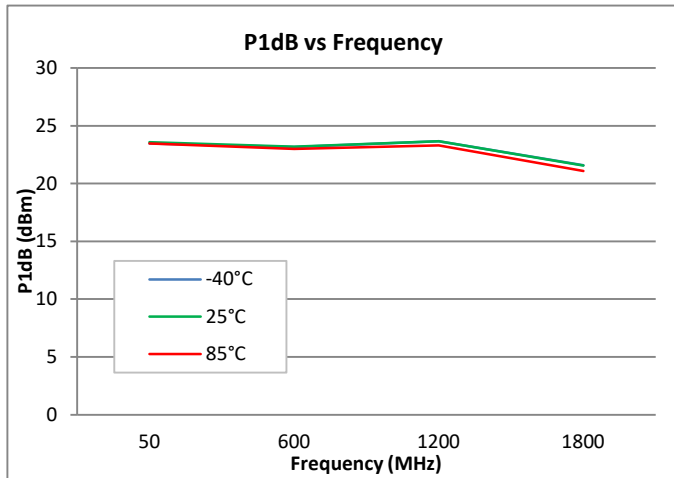
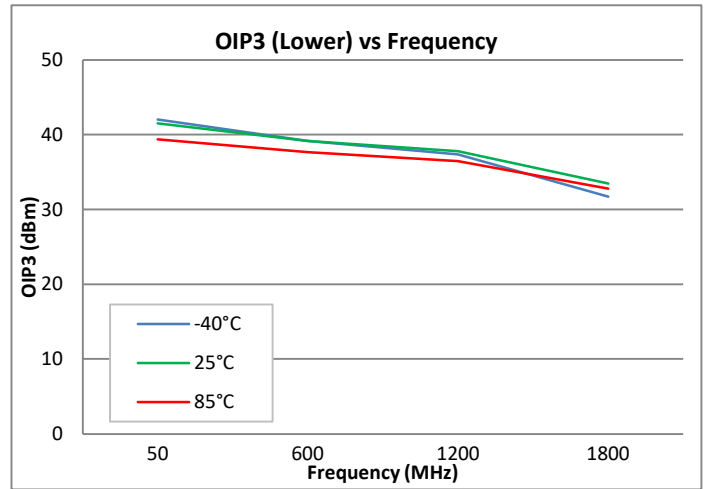
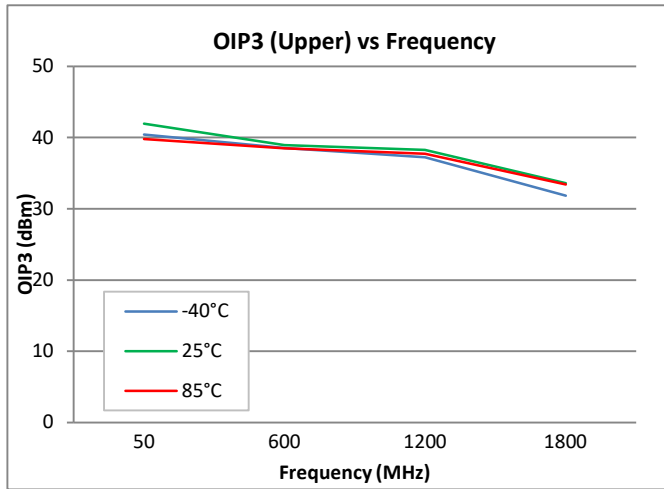

Notes:

1. OIP2: +5dBm / tone output, $\Delta f = 50$ MHz, Full Band
2. OIP3: +5dBm / tone output, $\Delta f = 6$ MHz, Full Band
3. MER: 111-1791MHz, 0dB Tilt, 1 OFDM + 244 QAM Channels

Pin Configuration and Description

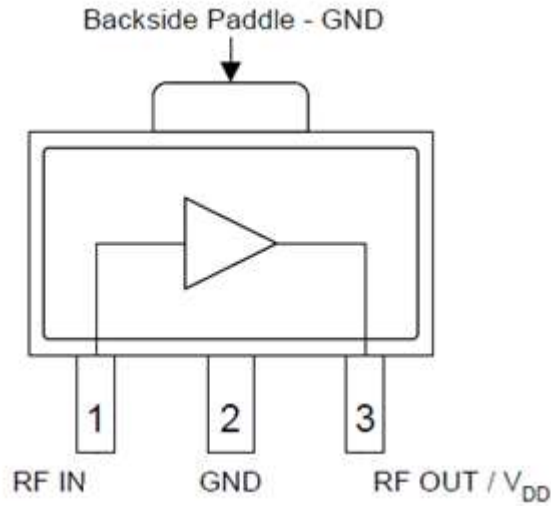

Top View

Pin Number	Label	Description
1	RF IN	RF Input, DC blocking capacitor required
2	GND	Internally Not Connected
3	RF OUT / VDD	RF Output – VDD bias choke required
Backside Paddle	GND	Ground. Use recommended via pattern to minimize inductance and thermal resistance. See PCB Mounting Pattern for suggested footprint.

Package Outline

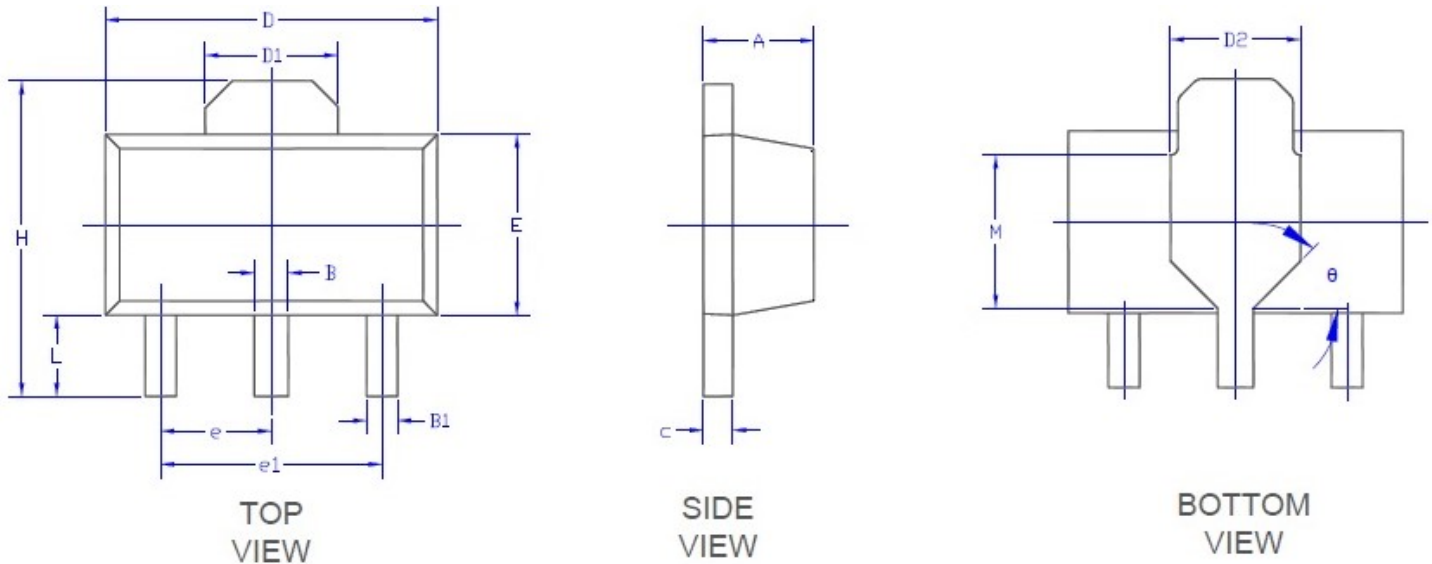

Symbol	Dimensions In Millimeters	
	Min.	Max.
A	1.400	1.600
B	0.400	0.580
B1	0.320	0.520
C	0.350	0.440
D	4.400	4.600
D1	1.550 REF.	
D2	1.600 REF.	

Symbol	Dimensions In Millimeters	
	Min.	Max.
E	2.300	2.600
e	1.500 TYP.	
e1	3.000 TYP.	
H	3.940	4.250
L	0.900	1.200
M	1.900 REF.	
θ	45°	

Package Marking

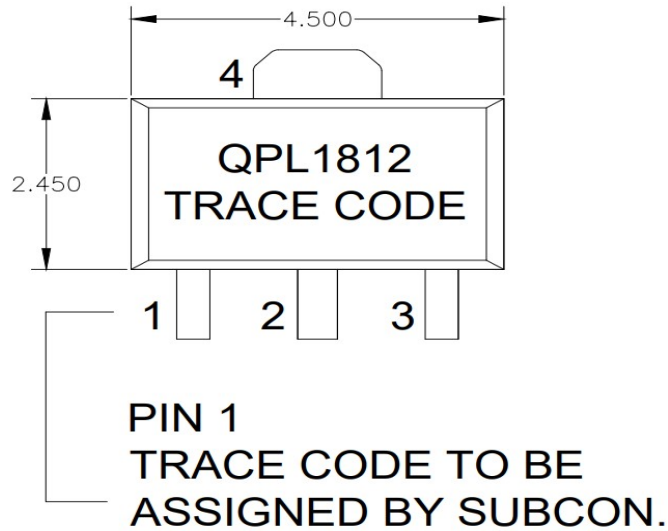

Recommended Mounting Pattern

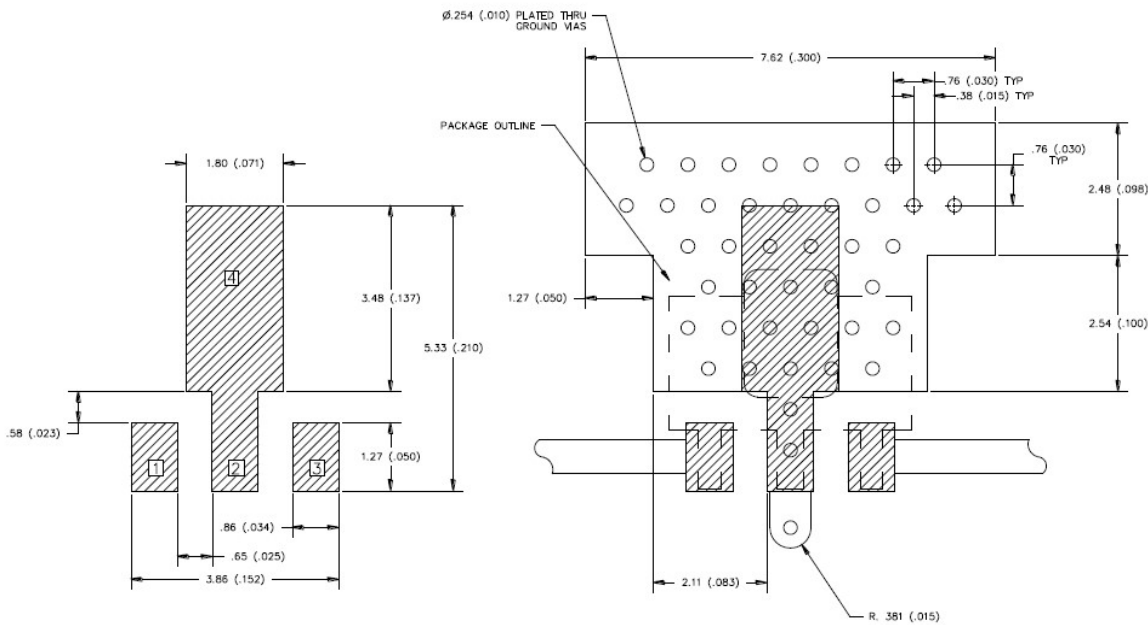

- Notes:
1. Ground/thermal vias are critical for the proper performance of this device. Vias should use a .35 mm (#80/.0135") diameter drill and have a final, plated thru diameter of 0.25 mm (0.010").
 2. Add as much copper as possible to inner and outer layers near the part to ensure optimal thermal performance.
 3. RF trace width depends upon the PC board material and construction.
 4. Ensure that the backside via region makes good physical contact with the heat sink.
 5. All dimensions are in millimeters (inches). Angles are in degrees.

Handling Precautions

Parameter	Rating	Standard
ESD – Human Body Model (HBM)	1A (250V to < 500V)	ANSI / ESDA / JEDEC JS-001
ESD – Charged Device Model (CDM)	C3 (≥1000V)	ANSI / ESDA / JEDEC JS-002
MSL – Moisture Sensitivity Level	Level 3	IPC / JEDEC J-STD-020



Caution!
ESD-Sensitive
Device

Solderability

Compatible with lead-free (260°C max. reflow temp.) soldering processes.
Solder profiles available upon request.

Contact plating: Matte Sn

RoHS Compliance

This part is compliant with 2011/65/EU RoHS directive (Restrictions on the Use of Certain Hazardous Substances in Electrical and Electronic Equipment) as amended by Directive 2015/863/EU.

This product also has the following attributes:

- Lead Free
- Halogen Free (Chlorine, Bromine)
- Antimony Free
- TBBP-A (C₁₅H₁₂Br₄O₂) Free
- PFOS Free
- SVHC Free



Contact Information

For the latest specifications, additional product information, worldwide sales and distribution locations:

Tel: 1-844-890-8163

Web: www.qorvo.com

Email: customer.support@qorvo.com

Important Notice

The information contained in this Data Sheet and any associated documents (“Data Sheet Information”) is believed to be reliable; however, Qorvo makes no warranties regarding the Data Sheet Information and assumes no responsibility or liability whatsoever for the use of said information. All Data Sheet Information is subject to change without notice. Customers should obtain and verify the latest relevant Data Sheet Information before placing orders for Qorvo® products. Data Sheet Information or the use thereof does not grant, explicitly, implicitly or otherwise any rights or licenses to any third party with respect to patents or any other intellectual property whether with regard to such Data Sheet Information itself or anything described by such information.

DATA SHEET INFORMATION DOES NOT CONSTITUTE A WARRANTY WITH RESPECT TO THE PRODUCTS DESCRIBED HEREIN, AND QORVO HEREBY DISCLAIMS ANY AND ALL WARRANTIES WITH RESPECT TO SUCH PRODUCTS WHETHER EXPRESS OR IMPLIED BY LAW, COURSE OF DEALING, COURSE OF PERFORMANCE, USAGE OF TRADE OR OTHERWISE, INCLUDING THE IMPLIED WARRANTIES OF MERCHANTABILITY AND FITNESS FOR A PARTICULAR PURPOSE. Without limiting the generality of the foregoing, Qorvo® products are not warranted or authorized for use as critical components in medical, life-saving, or life-sustaining applications, or other applications where a failure would reasonably be expected to cause severe personal injury or death. Applications described in the Data Sheet Information are for illustrative purposes only. Customers are responsible for validating that a particular product described in the Data Sheet Information is suitable for use in a particular application.

© 2024 Qorvo US, Inc. All rights reserved. This document is subject to copyright laws in various jurisdictions worldwide and may not be reproduced or distributed, in whole or in part, without the express written consent of Qorvo US, Inc. | QORVO® is a registered trademark of Qorvo US, Inc.

Looking for pricing, stock, or lifecycle information?

Click below to explore more details on WIN SOURCE:

 [View QPL1812SR on WIN SOURCE](#)

 [Qorvo US Inc. Information](#)

Optimize Your Supply Chain with WIN SOURCE Solutions

-  Global Sourcing Solution
-  Obsolete Management
-  Cost Control Management
-  Shortage Management
-  Alternative Solution
-  Excess Inventory Management