

MAX32655

Low-Power, Arm Cortex-M4 Processor with FPU-Based Microcontroller and Bluetooth 5.2

General Description

The MAX32655 microcontroller (MCU) is an advanced system-on-chip (SoC) featuring an Arm® Cortex®-M4F CPU for efficient computation of complex functions and algorithms that is qualified to operate at a temperature range of -40°C to +105°C. The SoC integrates power regulation and management with a single inductor multiple-output (SIMO) buck regulator system. The latest generation Bluetooth® 5.2 Low Energy (LE) radio is on board, supporting long-range (coded) and high-throughput modes and medical body area network (MBAN).

The device offers large onboard memory with 512KB flash and 128KB SRAM, with optional error correction coding (ECC) on one 32KB SRAM bank. This 32KB bank can be optionally retained in BACKUP mode. An 8KB user OTP area is available.

The MAX32655 supports multiple high-speed peripherals, such as I²C, 50MHz SPI, and UART, plus one I²S port for connecting to an audio codec. An eight-input, 10-bit ADC is available to monitor analog input from external analog sources. In addition, a low-power UART (LPUART) is available for operation in the lowest power sleep modes to facilitate wake-up activity without any data loss. A total of six timers with I/O capability are provided, including two low-power timers to enable pulse counting, capture/compare, and pulse-width modulation (PWM) generation, even in the lowest power sleep modes.

The MAX32655 is available in two different packages:

- 81 CTBGA (8mm x 8mm, 0.8mm pitch)
- 51 WLP (3.09mm x 3.09mm, 0.35mm pitch)

Applications

- Asset Tracking
- Fitness/Health and Medical Wearables
- Hearables
- Industrial Sensors
- Wireless Computer Peripherals and I/O Devices

Benefits and Features

- Ultra-Low-Power Wireless Microcontroller
 - Internal 100MHz Oscillator
 - Flexible Low-Power Modes with 7.3728MHz System Clock Option
 - 512KB Flash and 128KB SRAM
 - Optional ECC on One 32KB SRAM Bank
 - 16KB Instruction Cache
- Bluetooth 5.2 LE Radio
 - Dedicated, Ultra-Low-Power, 32-Bit RISC-V Coprocessor to Offload Timing-Critical Bluetooth Processing
 - Fully Open-Source Bluetooth 5.2 Stack Available
 - Supports Medical Body Area Network (MBAN)
 - High-Throughput (2Mbps) Mode
 - Long-Range (125kbps and 500kbps) Modes
 - Rx Sensitivity: -97dBm; Tx Power: +5.5dBm
 - Single-Ended Antenna Connection (50Ω)
- Power Management Maximizes Battery Life
 - 2.0V to 3.6V Supply Voltage Range
 - Integrated SIMO Power Regulator
 - 12.9µA/MHz Active Current at 3.0V
 - 1.53µA at 3.0V Retention Current for 32KB
 - Selectable SRAM Retention + RTC in Low-Power Modes
- Multiple Peripherals for System Control
 - Up to Two High-Speed SPI Controller/Target
 - Up to Three I²C Controller/Target
 - Up to Four UARTs
 - Up to One I²S Controller/Target
 - Up to 8-Input, 10-Bit Sigma-Delta ADC 7.8ksps
 - Up to Four Micro-Power Comparators
 - Timers: Four 32-Bit, Two Low Power, One Watchdog, One Low-Power Watchdog
 - 1-Wire® Controller
 - Up to Four Pulse Train (PWM) Engines
 - RTC with Wake-Up Timer
 - Up to 52 GPIOs
- Security and Integrity
 - Optional Secure Boot
 - TRNG Seed Generator
 - AES 128/192/256 Hardware Acceleration Engine

1-Wire is a registered trademark of Maxim Integrated Products, Inc.

Arm, Cordio, and Cortex are registered trademarks of Arm Limited (or its subsidiaries) in the US and/or elsewhere.

Bluetooth is a trademark of Bluetooth SIG, Inc.

[Ordering Information](#) appears at end of data sheet.

19-100883; Rev 4; 1/24

© 2024 Analog Devices, Inc. All rights reserved. Trademarks and registered trademarks are the property of their respective owners.

One Analog Way, Wilmington, MA 01887 U.S.A. | Tel: 781.329.4700 | © 2024 Analog Devices, Inc. All rights reserved.

Simplified Block Diagram

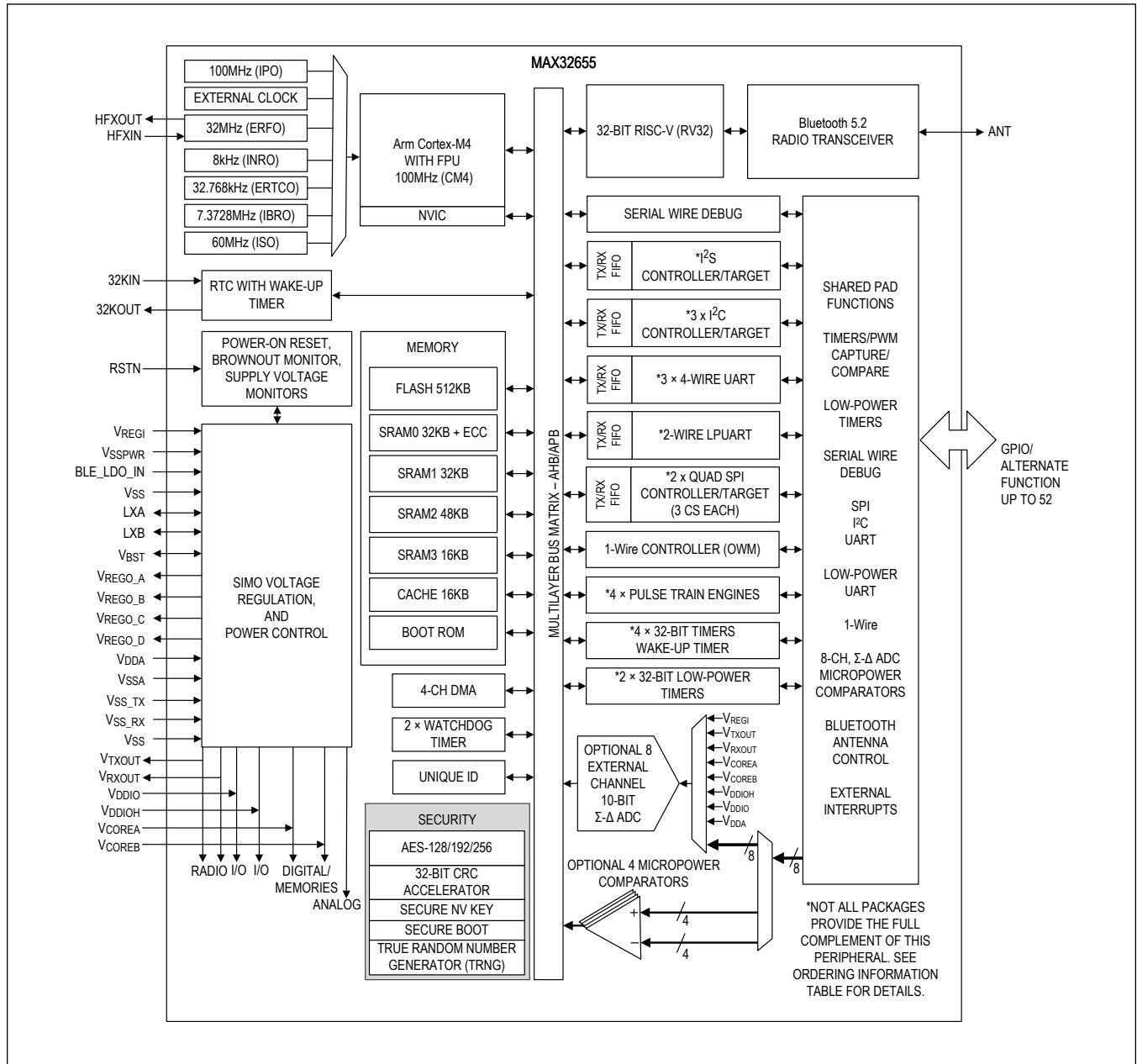

TABLE OF CONTENTS

General Description	1
Applications	1
Benefits and Features	1
Simplified Block Diagram	2
Absolute Maximum Ratings	7
Package Information	8
81 CTBGA	8
51 WLP	8
Electrical Characteristics	9
Electrical Characteristics—SPI	21
Electrical Characteristics—I ² C	22
Electrical Characteristics—I ² S	24
Electrical Characteristics—1-Wire Controller	24
Pin Configuration	29
81 CTBGA	29
Pin Descriptions – 81 CTBGA	30
Pin Configuration	35
51 WLP	35
Pin Descriptions – 51 WLP	35
Detailed Description	40
Arm Cortex-M4 (CM4) with FPU Processor and RISC-V (RV32) Processor	40
Memory	40
Internal Flash Memory	40
Internal SRAM	40
Bluetooth 5.2	40
Bluetooth 5.2 Low Energy Radio	40
Bluetooth 5.2 Software Stack	41
Comparators	41
Clocking Scheme	42
General-Purpose I/O (GPIO) and Special Function Pins	44
Analog-to-Digital Converter (ADC)	45
Single-Inductor Multiple-Output (SIMO) Switch-Mode Power Supply (SMPS)	45
Power Management	46
Power Management Unit (PMU)	46
ACTIVE Mode	46
SLEEP Mode	46
LOW POWER Mode (LPM)	46
MICRO POWER Mode (UPM)	46
STANDBY Mode	47

TABLE OF CONTENTS (CONTINUED)

BACKUP Mode	47
POWER DOWN Mode (PDM)	48
Wake-up Sources	48
Real-Time Clock (RTC)	48
Programmable Timers	49
32-Bit Timer/Counter/PWM (TMR, LPTMR)	49
Watchdog Timer (WDT)	49
Pulse Train Engine (PT)	50
Serial Peripherals	50
I ² C Interface (I2C)	50
I ² S Interface (I2S)	51
Serial Peripheral Interface (SPI)	51
UART (UART, LPUART)	52
1-Wire Controller (OWM)	53
Standard DMA Controller	53
Security	53
AES	53
True Random Number Generator (TRNG)	53
CRC Module	54
Secure Communications Protocol Bootloader (SCPBL)	54
Secure Boot	54
Debug and Development Interface (SWD, JTAG)	54
Applications Information	55
Bypass Capacitors	55
RTC Crystal Guidelines	55
Device PCB Power Connectivity	55
V _{REGI} Design Considerations	55
Transmitted Spurious Emissions	56
Typical Fixed Current Consumption Temperature Variance	56
ACTIVE Mode	56
SLEEP Mode	56
STANDBY Mode	56
BACKUP Mode	56
Ordering Information	57
Revision History	58

LIST OF FIGURES

Figure 1. Example 81 CTBGA Top Marking	8
Figure 2. Example 51 WLP Top Marking	9
Figure 3. SPI Controller Mode Timing Diagram	26
Figure 4. SPI Target Mode Timing Diagram	26
Figure 5. I ² C Timing Diagram	27
Figure 6. I ² S Target Timing Diagram	27
Figure 7. 1-Wire Controller Data Timing Diagram	28
Figure 8. 81 CTBGA Clocking Scheme Diagram	43
Figure 9. 51 WLP Clocking Scheme Diagram	44

LIST OF TABLES

Table 1. MAX32655 Comparator Instances	42
Table 2. MAX32655 ADC External Inputs	45
Table 3. BACKUP Mode SRAM Retention	48
Table 4. MAX32655 Wake-up Sources	48
Table 5. MAX32655 Timer Instances	49
Table 6. MAX32655 Watchdog Timer Instances	50
Table 7. MAX32655 Pulse Train Instances	50
Table 8. MAX32655 I ² C Instances	51
Table 9. MAX32655 SPI Instances	52
Table 10. MAX32655 UART Instances	52
Table 11. Common CRC Polynomials	54
Table 12. Device PCB Power Connectivity	55
Table 13. MAX32655 V _{REG1} Capacitor Placement Priority	56
Table 14. Fixed V _{REG1} Current Consumption ACTIVE Mode	56
Table 15. Fixed V _{REG1} Current Consumption SLEEP Mode	56
Table 16. Fixed V _{REG1} Current Consumption STANDBY Mode	56
Table 17. Fixed V _{REG1} Current Consumption BACKUP Mode	56

Absolute Maximum Ratings

V _{COREA} , V _{COREB}	-0.3V to +1.21V	V _{SSA}	100mA
V _{DDIO}	-0.3V to +1.89V	V _{SS} , V _{SS_TX} , V _{SS_RX}	100mA
V _{DDIOH}	-0.3V to +3.6V	V _{SSPWR}	100mA
V _{REGI}	-0.3V to +3.6V	Continuous Package Power Dissipation CTBGA (multilayer board) T _A = +70°C (derate 24.10mW/°C above +70°C)	1928.18mW
V _{DDA}	-0.3V to +1.89V	Continuous Package Power Dissipation 51 WLP (multilayer board) T _A = +70°C (derate 20.75mW/°C above +70°C)	1660.1mW
BLE_LDO_IN	-0.3V to +1.5V	Operating Temperature Range	-40°C to +105°C
RSTN, GPIO (V _{DDIOH}) (Note 1)	-0.3V to V _{DDIOH} + 0.5V	Storage Temperature Range	-65°C to +125°C
GPIO (V _{DDIO}) (Note 2)	-0.3V to V _{DDIO} + 0.5V	Soldering Temperature	+260°C
32KIN, 32KOUT (Note 2)	-0.3V to V _{DDA} + 0.2V		
Output Current (sink) by Any GPIO Pin	25mA		
Output Current (source) by Any GPIO Pin	-25mA		
V _{DDIO} Combined Pins (sink) (Note 3)	50mA		
V _{DDIOH} Combined Pins (sink)	100mA		

Note 1: These device pins cannot exceed 3.63V. All voltages with respect to V_{SS}, unless otherwise noted.

Note 2: These device pins cannot exceed 1.89V. All voltages with respect to V_{SS}, unless otherwise noted.

Note 3: This maximum current is limited by the V_{REGO_A} regulator output. See [Device PCB Power Connectivity](#).

Stresses beyond those listed under "Absolute Maximum Ratings" may cause permanent damage to the device. These are stress ratings only, and functional operation of the device at these or any other conditions beyond those indicated in the operational sections of the specifications is not implied. Exposure to absolute maximum rating conditions for extended periods may affect device reliability.

Package Information

81 CTBGA

Package Code	X8188+4C
Outline Number	21-0735
Land Pattern Number	90-0460
Thermal Resistance, Four-Layer Board:	
Junction to Ambient (θ_{JA})	41.49°C/W
Junction to Case (θ_{JC})	10.81°C/W

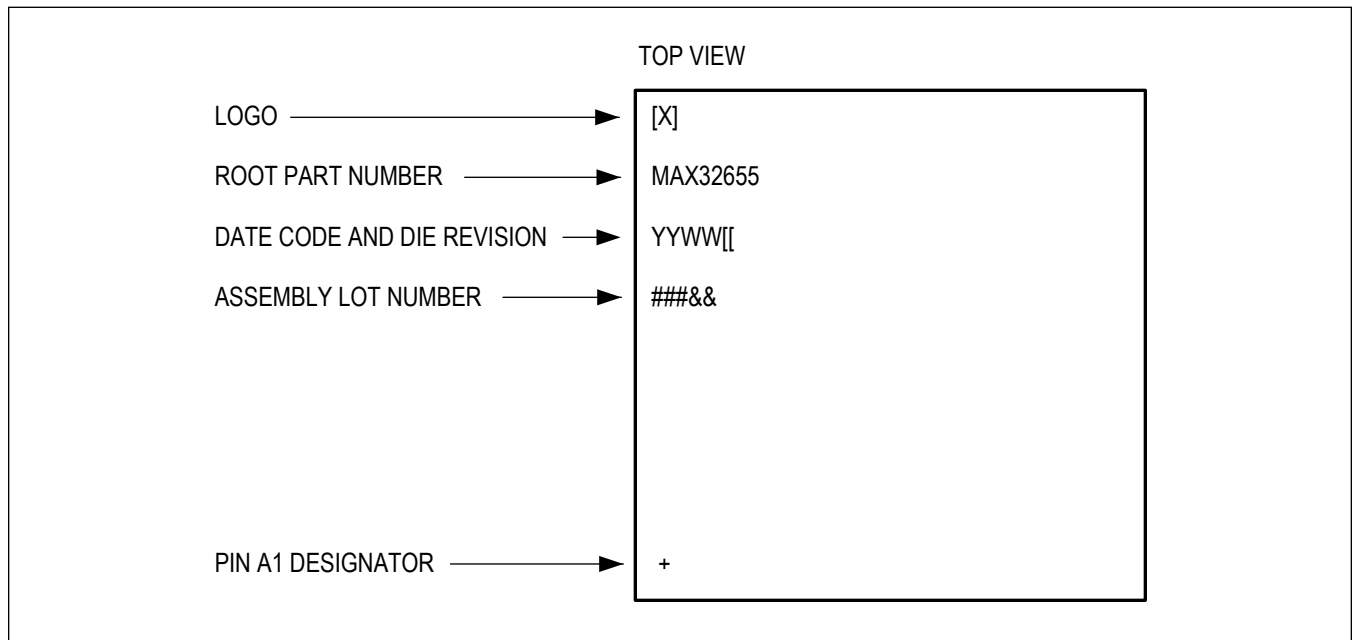

Figure 1. Example 81 CTBGA Top Marking

For the latest package outline information and land patterns (footprints), go to the [Package Index](#) on the Analog Devices website. Note that a “+”, “#”, or “-” in the package code indicates RoHS status only. Package drawings may show a different suffix character, but the drawing pertains to the package regardless of RoHS status.

Package thermal resistances were obtained using the method described in JEDEC specification JESD51-7, using a four-layer board. For detailed information on package thermal considerations, refer to [Thermal Characterization of IC Packages](#).

51 WLP

Package Code	W513A3+1
Outline Number	21-100711
Land Pattern Number	Refer to Application Note 1891
Thermal Resistance, Four-Layer Board:	
Junction to Ambient (θ_{JA})	20.75°C/W
Junction to Case (θ_{JC})	N/A

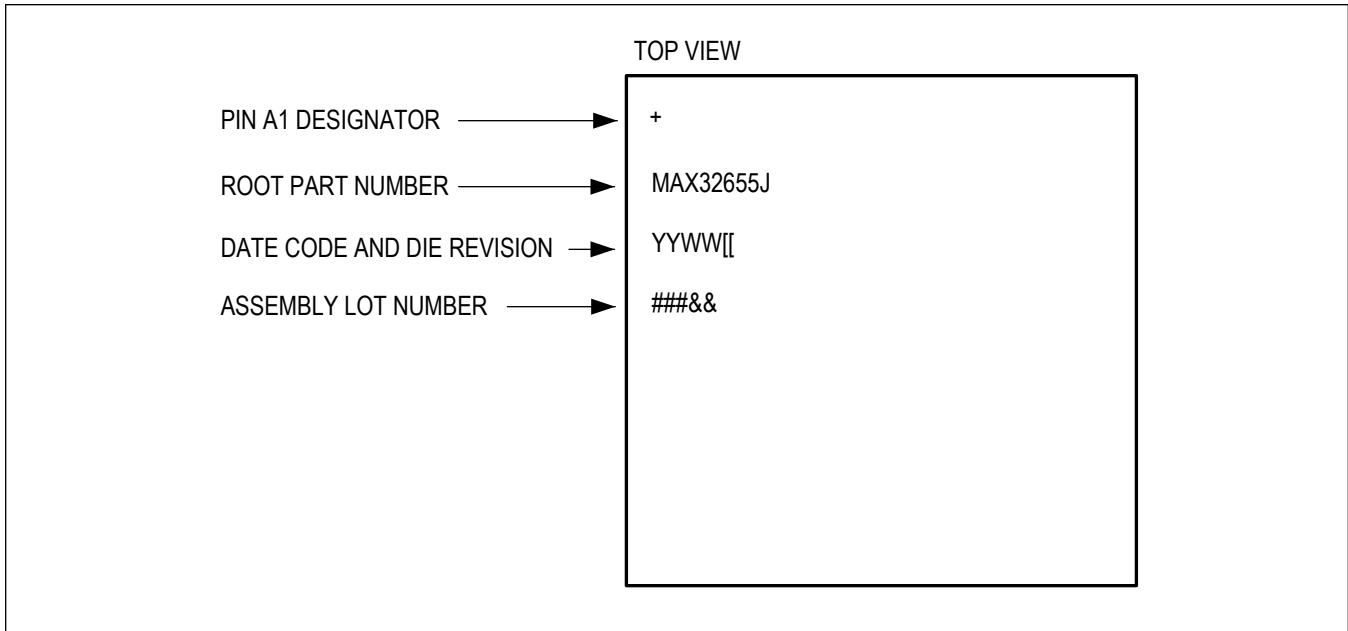

Figure 2. Example 51 WLP Top Marking

For the latest package outline information and land patterns (footprints), go to the [Package Index](#) on the Analog Devices website. Note that a “+”, “#”, or “-” in the package code indicates RoHS status only. Package drawings may show a different suffix character, but the drawing pertains to the package regardless of RoHS status.

Package thermal resistances were obtained using the method described in JEDEC specification JESD51-7, using a four-layer board. For detailed information on package thermal considerations, refer to [Thermal Characterization of IC Packages](#).

Electrical Characteristics

(All specifications and characteristics apply across the entire operating conditions range unless otherwise noted.)

PARAMETER	SYMBOL	CONDITIONS	MIN	TYP	MAX	UNITS
POWER SUPPLIES						
Core Input Supply Voltage A	V _{COREA}		0.99	1.1	1.21	V
Core Input Supply Voltage B	V _{COREB}		0.81	1.1	1.21	V
Input Supply Voltage, Battery	V _{REGI}	If power to the device is cycled, V _{REGI} must exceed V _{REGI_POR(MIN)} within 20ms after V _{DDA} > 1.24V. After that, V _{REGI} can settle to its final value.	2.0	3.0	3.6	V
	V _{REGI_POR}		2.45			
Input Supply Voltage, Analog	V _{DDA}		1.71	1.8	1.89	V
Input Supply Voltage, GPIO	V _{DDIO}		1.71	1.8	1.89	V
Input Supply Voltage, GPIO (High)	V _{DDIOH}		2.0	3.0	3.6	V

Electrical Characteristics (continued)

(All specifications and characteristics apply across the entire operating conditions range unless otherwise noted.)

PARAMETER	SYMBOL	CONDITIONS	MIN	TYP	MAX	UNITS
Power-Fail Reset Voltage	V_{RST}	Monitors V_{COREA}		0.84		V
		Monitors V_{COREB}	0.69	0.73		
		Monitors V_{DDA}	1.58	1.64	1.69	
		Monitors V_{DDIO}	1.58	1.64	1.69	
		Monitors V_{DDIOH}	1.58	1.64	1.69	
		Monitors V_{REGI}	1.91	1.98	2.08	
		Monitors V_{RXOUT}		0.773		
		Monitors V_{TXOUT}		0.773		
Power-on Reset Voltage	V_{POR}	Monitors V_{COREA}		0.57		V
		Monitors V_{DDA}		1.25		

Electrical Characteristics (continued)

(All specifications and characteristics apply across the entire operating conditions range unless otherwise noted.)

PARAMETER	SYMBOL	CONDITIONS	MIN	TYP	MAX	UNITS
V _{REGI} Current, ACTIVE Mode	I _{REGI_DACT}	Dynamic, IPO enabled, ISO disabled, f _{SYS_CLK(MAX)} = 100MHz, total current into V _{REGI} pin, V _{REGI} = 3.0V, V _{COREA} = 1.0V, V _{COREB} = 0.81V, CM4 in ACTIVE mode executing Coremark®, RV32 in SLEEP mode, ECC disabled; inputs tied to V _{SS} , V _{DDIO} , or V _{DDIOH} ; outputs source/sink 0mA		18.9		μA/MHz
		Dynamic, IPO enabled, ISO disabled, f _{SYS_CLK(MAX)} = 100MHz, total current into V _{REGI} pin, V _{REGI} = 3.0V, V _{COREA} = 1.0V, V _{COREB} = 0.81V, CM4 and RV32 in ACTIVE mode executing While(1), ECC disabled; inputs tied to V _{SS} , V _{DDIO} , or V _{DDIOH} ; outputs source/sink 0mA. This specification is a function of the IPO frequency.		19.0		
		Dynamic, IPO enabled, ISO disabled, f _{SYS_CLK(MAX)} = 100MHz, total current into V _{REGI} pin, V _{REGI} = 3.0V, V _{COREA} = 1.0V, V _{COREB} = 0.81V, CM4 in ACTIVE mode executing While(1), RV32 in SLEEP mode, ECC disabled; inputs tied to V _{SS} , V _{DDIO} , or V _{DDIOH} ; outputs source/sink 0mA		12.9		
		Dynamic, total current into V _{REGI} pin, V _{REGI} = 3.0V, V _{COREA} = 1.0V, V _{COREB} = 0.81V, CM4 in SLEEP mode, RV32 in ACTIVE mode running from ISO, ECC disabled; inputs tied to V _{SS} , V _{DDIO} , or V _{DDIOH} ; outputs source/sink 0mA		18.3		
	I _{REGI_FACT}	Fixed, IPO enabled, ISO disabled, total current into V _{REGI} ; V _{REGI} = 3.0V, V _{COREA} = 1.0V, V _{COREB} = 0.81V, CM4 in ACTIVE mode 0MHz, RV32 in ACTIVE mode 0MHz; inputs tied to V _{SS} , V _{DDIO} , or V _{DDIOH} ; outputs source/sink 0mA. See Temperature Variance .		582.1		μA
		Fixed, IPO disabled, ISO enabled, total current into V _{REGI} ; V _{REGI} = 3.0V, V _{COREA} = 1.0V, V _{COREB} = 0.81V, CM4 in ACTIVE mode 0MHz, RV32 in ACTIVE mode 0MHz; inputs tied to V _{SS} , V _{DDIO} , or V _{DDIOH} ; outputs source/sink 0mA. See Temperature Variance .		446		

Electrical Characteristics (continued)

(All specifications and characteristics apply across the entire operating conditions range unless otherwise noted.)

PARAMETER	SYMBOL	CONDITIONS	MIN	TYP	MAX	UNITS
V _{REGI} Current, SLEEP Mode	I _{REGI_DSLP}	Dynamic, IPO enabled, ISO disabled, f _{SYS_CLK(MAX)} = 100MHz, ISO enabled, total current into V _{REGI} pins, V _{REGI} = 3.0V, V _{COREA} = 1.0V, V _{COREB} = 0.81V, CM4 in SLEEP mode, RV32 in SLEEP mode, ECC disabled, standard DMA with two channels active; inputs tied to V _{SS} , V _{DDIO} , or V _{DDIOH} ; outputs source/sink 0mA		8.76		μA/MHz
	I _{REGI_FSLP}	Fixed, IPO enabled, ISO disabled, total current into V _{REGI} pins, V _{REGI} = 3.0V, V _{COREA} = 1.0V, V _{COREB} = 0.81V, CM4 in SLEEP mode, RV32 in SLEEP mode, ECC disabled; inputs tied to V _{SS} , V _{DDIO} , or V _{DDIOH} ; outputs source/sink 0mA. See Temperature Variance .		582.1		μA
V _{REGI} Current, LOW POWER Mode	I _{REGI_DLP}	Dynamic, IPO disabled, ISO enabled, total current into V _{REGI} pins, V _{REGI} = 3.0V, V _{COREA} = 1.0V, V _{COREB} = 0.81V, CM4 powered off, RV32 in ACTIVE mode running While(1), f _{SYS_CLK(MAX)} = 60MHz; inputs tied to V _{SS} , V _{DDIO} , or V _{DDIOH} ; outputs source/sink 0mA		18.30		μA/MHz
	I _{REGI_FLP}	Fixed, IPO disabled, ISO enabled, total current into V _{REGI} pins, V _{REGI} = 3.0V, V _{COREA} = 1.0V, V _{COREB} = 0.81V, CM4 powered off, RV32 in ACTIVE mode 0MHz; inputs tied to V _{SS} , V _{DDIO} , or V _{DDIOH} ; outputs source/sink 0mA		446		μA
V _{REGI} Current, MICRO POWER Mode	I _{REGI_DMP}	Dynamic, ERTCO enabled, IBRO enabled, total current into V _{REGI} pins, V _{REGI} = 3.0V, V _{COREA} = 1.0V, V _{COREB} = 0.81V, LPUART active, f _{LPUART} = 32.768kHz; inputs tied to V _{SS} , V _{DDIO} , or V _{DDIOH} ; outputs source/sink 0mA		230		μA
V _{REGI} Current, STANDBY Mode	I _{REGI_STBY}	Fixed, total current into V _{REGI} pins, V _{REGI} = 3.0V, V _{COREA} = 1.0V, V _{COREB} = 0.81V; inputs tied to V _{SS} , V _{DDIO} , or V _{DDIOH} ; outputs source/sink 0mA. See Temperature Variance .		2.1		μA

Electrical Characteristics (continued)

(All specifications and characteristics apply across the entire operating conditions range unless otherwise noted.)

PARAMETER	SYMBOL	CONDITIONS	MIN	TYP	MAX	UNITS
V _{REGI} Current, BACKUP Mode	I _{REGI_BK}	Total current into V _{REGI} pins, V _{REGI} = 3.0V, V _{COREA} = 1.0V, V _{COREB} = 0.81V, RTC disabled; inputs tied to V _{SS} , V _{DDIO} , or V _{DDIOH} ; outputs source/sink 0mA. See Temperature Variance .	All SRAM retained, 25°C		1.6	μA
		Total current into V _{REGI} pins, V _{REGI} = 3.0V, V _{COREA} = 1.0V, V _{COREB} = 0.81V, RTC disabled; inputs tied to V _{SS} , V _{DDIO} , or V _{DDIOH} , outputs source/sink 0mA. See Temperature Variance .	No SRAM retention, 25°C		0.98	
		Total current into V _{REGI} pins, V _{REGI} = 3.0V, V _{COREA} = 1.0V, V _{COREB} = 0.81V, RTC disabled; inputs tied to V _{SS} , V _{DDIO} , or V _{DDIOH} ; outputs source/sink 0mA. See Temperature Variance .	SRAM0 retained, 25°C		1.14	
			SRAM0 and SRAM1 retained, 25°C		1.29	
V _{REGI} Current, POWER DOWN Mode	I _{REGI_PDM}	Total current into V _{REGI} pins, V _{REGI} = 3.0V, V _{COREA} = 1.0V, V _{COREB} = 0.81V; inputs tied to V _{SS} , V _{DDIO} , or V _{DDIOH} ; outputs source/sink 0mA	SRAM0, SRAM1, and SRAM2 retained		1.53	μA
					0.09	
V _{REGO_X} Output Current	V _{REGO_X_IOUT}	Output current for each of the V _{REGO_X} outputs		5	50	mA
V _{REGO_X} Output Current Combined	V _{REGO_X_IOUT_TOT}	All four V _{REGO_X} outputs combined		15	100	mA
V _{REGO_X} Output Voltage Range	V _{REGO_X_RANGE}	V _{REGI} ≥ V _{REGO_X} + 200mV; output voltage range must be configured to meet the input voltage range of the load device pin (V _{RST} to V _{MAX})	V _{RST}	1.0	V _{MAX}	V
V _{REGO_X} Efficiency	V _{REGO_X_EFF}	V _{REGI} = 2.7V, V _{REGO_X} = 1.1V, load = 30mA		90		%
SLEEP Mode Resume Time	t _{SLEEP_ON}	Time from power mode exit to execution of first user instruction		0.847		μs
LOW POWER Mode Resume Time	t _{LP_ON}	Time from power mode exit to execution of first user instruction		6.08		μs

Electrical Characteristics (continued)

(All specifications and characteristics apply across the entire operating conditions range unless otherwise noted.)

PARAMETER	SYMBOL	CONDITIONS	MIN	TYP	MAX	UNITS
MICRO POWER Mode Resume Time	t_{MP_ON}	Time from power mode exit to execution of first user instruction		12.4		μs
STANDBY Mode Resume Time	t_{STBY_ON}	Time from power mode exit to execution of first user instruction		14.7		μs
BACKUP Mode Resume Time	t_{BKU_ON}	Time from power mode exit to execution of first user instruction		1.15		ms
POWER DOWN Mode Resume Time	t_{PDM_ON}	Time from power mode exit to execution of first user instruction		5		ms
CLOCKS						
System Clock Frequency	f_{SYS_CLK}				100,000	kHz
Internal Primary Oscillator (IPO)	f_{IPO}			100		MHz
Internal Secondary Oscillator (ISO)	f_{ISO}			60		MHz
Internal Baud Rate Oscillator (IBRO)	f_{IBRO}			7.3728		MHz
Internal Nano-Ring Oscillator (INRO)	f_{INRO}	8kHz selected		8		kHz
		16kHz selected		16		
		30kHz selected		30		
External RTC Oscillator (ERTCO)	f_{ERTCO}	32kHz watch crystal. Required crystal characteristics: $C_L_XTAL = 6\text{pF}$, $ESR < 90\text{k}\Omega$, $C_0 \leq 2\text{pF}$, crystal power dissipation rating minimum $0.5\mu\text{W}$, no external load capacitors, see RTC Crystal Guidelines . The accuracy is determined by the crystal and PCB layout.		32.768		kHz
External RF Oscillator Frequency (ERFO)	f_{ERFO}	The oscillator accepts a crystal between 16MHz and 32MHz. Required crystal characteristics: $C_L_XTAL = 12\text{pF}$, $ESR \leq 50\Omega$, $C_0 \leq 7\text{pF}$, crystal power dissipation rating of $100\mu\text{W}$ (min). Refer to the device user guide for calculating the load capacitors. The accuracy is determined by the crystal and PCB layout. If the ERFO is used for Bluetooth LE operation, the frequency must be 32MHz, the temperature stability must be $\pm 20\text{ppm}$ and the initial tolerance must be $\pm 20\text{ppm}$.		16–32		MHz
RTC Operating Current	I_{RTC}	All power modes, RTC enabled		0.3		μA
RTC Power-Up Time	t_{RTC_ON}			250		ms
Input Low Voltage 32KIN	V_{IL_32K}			$0.3 \times V_{DDA}$		V
Input High Voltage 32KIN	V_{IH_32K}			$0.7 \times V_{DDA}$		V

Electrical Characteristics (continued)

(All specifications and characteristics apply across the entire operating conditions range unless otherwise noted.)

PARAMETER	SYMBOL	CONDITIONS		MIN	TYP	MAX	UNITS
External System Clock Input Frequency	f_{EXT_CLK}	EXT_CLK selected. Drive this input with a square wave from 0V to V_{DDIOH} with V_{DDIOH} selected as the I/O supply.				80	MHz
		EXT_CLK selected. Drive this input with a square wave from 0V to V_{DDIO} with V_{DDIO} selected as the I/O supply.				80	
External Low-Power Timer 1 Clock Input Frequency	$f_{EXT_LPTMR1_CLK}$	LPTMR1_CLK selected				8	MHz
External Low-Power Timer 2 Clock Input Frequency	$f_{EXT_LPTMR2_CLK}$	LPTMR2_CLK selected				8	MHz
GENERAL-PURPOSE I/O							
Input Low Voltage for All GPIO Except P3.0 and P3.1	V_{IL_VDDIO}	P3.0 and P3.1 can only use V_{DDIOH} as I/O supply and cannot use V_{DDIO} as I/O supply	V_{DDIO} selected as I/O supply			$0.3 \times V_{DDIO}$	V
Input Low Voltage for All GPIO	V_{IL_VDDIOH}	V_{DDIOH} selected as I/O supply				$0.3 \times V_{DDIOH}$	V
Input Low Voltage for RSTN	V_{IL_RSTN}				$0.5 \times V_{DDIOH}$		V
Input High Voltage for All GPIO Except P3.0 and P3.1	V_{IH_VDDIO}	P3.0 and P3.1 can only use V_{DDIOH} as I/O supply and cannot use V_{DDIO} as I/O supply	V_{DDIO} selected as I/O supply	$0.7 \times V_{DDIO}$			V
Input High Voltage for All GPIO	V_{IH_VDDIOH}	V_{DDIOH} selected as I/O supply		$0.7 \times V_{DDIOH}$			V
Input High Voltage for RSTN	V_{IH_RSTN}				$0.5 \times V_{DDIOH}$		V

Electrical Characteristics (continued)

(All specifications and characteristics apply across the entire operating conditions range unless otherwise noted.)

PARAMETER	SYMBOL	CONDITIONS	MIN	TYP	MAX	UNITS	
Output Low Voltage for All GPIO Except P3.0 and P3.1	V _{OL_VDDIO}	P3.0 and P3.1 can only use V _{DDIOH} as I/O supply and cannot use V _{DDIO} as I/O supply	V _{DDIO} selected as I/O supply, V _{DDIO} = 1.71V, GPIO _n _DS_SEL[1:0] = 00, I _{OL} = 1mA		0.2	0.4	V
			V _{DDIO} selected as I/O supply, V _{DDIO} = 1.71V, GPIO _n _DS_SEL[1:0] = 01, I _{OL} = 2mA		0.2	0.4	
			V _{DDIO} selected as I/O supply, V _{DDIO} = 1.71V, GPIO _n _DS_SEL[1:0] = 10, I _{OL} = 4mA		0.2	0.4	
			V _{DDIO} selected as I/O supply, V _{DDIO} = 1.71V, GPIO _n _DS_SEL[1:0] = 11, I _{OL} = 8mA		0.2	0.4	
Output Low Voltage for All GPIO	V _{OL_VDDIOH}	V _{DDIOH} selected as I/O supply, V _{DDIOH} = 1.71V, GPIO _n _DS_SEL[1:0] = 00, I _{OL} = 1mA		0.2	0.4	V	
		V _{DDIOH} selected as I/O supply, V _{DDIOH} = 1.71V, GPIO _n _DS_SEL[1:0] = 01, I _{OL} = 2mA		0.2	0.4		
		V _{DDIOH} selected as I/O supply, V _{DDIOH} = 1.71V, GPIO _n _DS_SEL[1:0] = 10, I _{OL} = 4mA		0.2	0.4		
		V _{DDIOH} selected as I/O supply, V _{DDIOH} = 1.71V, GPIO _n _DS_SEL[1:0] = 11, I _{OL} = 8mA		0.2	0.4		
Combined I _{OL} , All GPIO	I _{OL_TOTAL}				48	mA	

Electrical Characteristics (continued)

(All specifications and characteristics apply across the entire operating conditions range unless otherwise noted.)

PARAMETER	SYMBOL	CONDITIONS	MIN	TYP	MAX	UNITS
Output High Voltage for All GPIO Except P3.0 and P3.1	V_{OH_VDDIO}	V_{DDIO} selected as I/O supply, $V_{DDIO} = 1.71V$, $GPIO_n_DS_SEL[1:0] = 00$, $I_{OL} = -1mA$	$V_{DDIO} - 0.4$			V
		V_{DDIO} selected as I/O supply, $V_{DDIO} = 1.71V$, $GPIO_n_DS_SEL[1:0] = 01$, $I_{OL} = -2mA$	$V_{DDIO} - 0.4$			
		V_{DDIO} selected as I/O supply, $V_{DDIO} = 1.71V$, $GPIO_n_DS_SEL[1:0] = 10$, $I_{OL} = -4mA$	$V_{DDIO} - 0.4$			
		V_{DDIO} selected as I/O supply, $V_{DDIO} = 1.71V$, $GPIO_n_DS_SEL[1:0] = 11$, $I_{OL} = -8mA$	$V_{DDIO} - 0.4$			
Output High Voltage for All GPIO Except P3.0 and P3.1	V_{OH_VDDIOH}	V_{DDIOH} selected as I/O supply, $V_{DDIOH} = 1.71V$, $GPIO_n_DS_SEL[1:0] = 00$, $I_{OL} = -1mA$	$V_{DDIOH} - 0.4$			V
		V_{DDIOH} selected as I/O supply, $V_{DDIOH} = 1.71V$, $GPIO_n_DS_SEL[1:0] = 01$, $I_{OL} = -2mA$	$V_{DDIOH} - 0.4$			
		V_{DDIOH} selected as I/O supply, $V_{DDIOH} = 1.71V$, $GPIO_n_DS_SEL[1:0] = 10$, $I_{OL} = -8mA$	$V_{DDIOH} - 0.4$			
		V_{DDIOH} selected as I/O supply, $V_{DDIOH} = 1.71V$, $GPIO_n_DS_SEL[1:0] = 11$, $I_{OL} = -8mA$	$V_{DDIOH} - 0.4$			
Output High Voltage for P3.0 and P3.1	V_{OH_VDDIOH}	$V_{DDIOH} = 1.71V$, $GPIO_n_DS_SEL[1:0]$ fixed at 00, $I_{OL} = -1mA$	$V_{DDIOH} - 0.4$			V
Combined I_{OH} , All GPIO	I_{OH_TOTAL}				-48	mA
Input Hysteresis (Schmitt)	V_{IHYS}			300		mV
Input Leakage Current Low	I_{IL}	$V_{DDIO} = 1.89V$, $V_{DDIOH} = 3.6V$, V_{DDIOH} selected as I/O supply, $V_{IN} = 0V$, internal pull-up disabled	-100		+100	nA
Input Leakage Current High	I_{IH}	$V_{DDIO} = 1.89V$, $V_{DDIOH} = 3.6V$, V_{DDIOH} selected as I/O supply, $V_{IN} = 3.6V$, internal pull-down disabled	-800		+800	nA
	I_{OFF}	$V_{DDIO} = 0V$, $V_{DDIOH} = 0V$, V_{DDIO} selected as I/O supply, $V_{IN} < 1.89V$	-1		+1	μA
	I_{IH3V}	$V_{DDIO} = V_{DDIOH} = 1.71V$, V_{DDIO} selected as I/O supply, $V_{IN} = 3.6V$	-2		+2	
Input Pull-up Resistor RSTN	R_{PU_R}	Pull-up to V_{DDIOH}		25		k Ω

Electrical Characteristics (continued)

(All specifications and characteristics apply across the entire operating conditions range unless otherwise noted.)

PARAMETER	SYMBOL	CONDITIONS	MIN	TYP	MAX	UNITS
Input Pull-up/Pull-down Resistor for All GPIO	R _{PU1}	Strong Pull-up		25		kΩ
	R _{PU2}	Weak Pull-up		1		MΩ
RSTN Assertion Time	t _{RSTN}	Device in ACTIVE mode, RSTN device pin assertion duration to entry into device reset state		6		μs
BLUETOOTH RADIO / POWER						
Bluetooth LDO Input Voltage	V _{BLE_LDO_IN}		0.9	1.1	1.5	V
BLUETOOTH RADIO / FREQUENCY						
Operating Frequency		1MHz channel spacing	2360		2500	MHz
PLL Programming Resolution	PLL _{RES}			1		MHz
Frequency Deviation at 1Mbps	Δf _{1MHz}			±170		kHz
Frequency Deviation at Bluetooth LE 1Mbps	Δf _{BLE1MHz}			±250		kHz
Frequency Deviation at 2Mbps	Δf _{2MHz}			±320		kHz
Frequency Deviation at Bluetooth LE 2Mbps	Δf _{BLE2MHz}			±500		kHz
BLUETOOTH RADIO / CURRENT CONSUMPTION (SIMO enabled, V_{REGI} = 3.3V. ISO enabled, f_{SYS_CLK} = 60MHz, Bluetooth LE stack running on RV32. Measured at the V_{REGI} device pin, V_{REGO_B} = 0.9V, V_{REGO_C} = 1.0V, CM4 in SLEEP mode.)						
Tx Run Current	I _{TX_+5.5DBM}	P _{RF} = +5.5dBm		7.42		mA
	I _{TX_0DBM}	P _{RF} = 0dBm		4.78		
	I _{TX_-10DBM}	P _{RF} = -10dBm		3.80		
Tx Startup Current	I _{START_TX}			2.25		mA
BLUETOOTH RADIO / CURRENT CONSUMPTION (SIMO enabled, V_{REGI} = 3.3V. ISO Enabled, f_{SYS_CLK} = 60MHz, BLE stack running on RV32. Measured at the V_{REGI} device pin, V_{REGO_B} = 0.9V, V_{REGO_C} = 1.0V, CM4 in SLEEP mode)						
Rx Run Current	I _{RX_1M}	f _{RX} = 1Mbps		4.41		mA
	I _{RX_2M}	f _{RX} = 2Mbps		4.45		
Rx Startup Current	I _{START_RX}			2.05		mA
BLUETOOTH RADIO / TRANSMITTER						
Maximum Output Power	P _{RF}			+5.5		dBm
RF Power Accuracy	P _{RF_ACC}			±1		dB
First Adjacent Channel Transmit Power ±2MHz	P _{RF1_1}	1Mbps Bluetooth LE		-30.5		dBc
First Adjacent Channel Transmit Power ±4MHz	P _{RF2_1}	1Mbps Bluetooth LE		-40		dBc
BLUETOOTH RADIO / RECEIVER						
Maximum Received Signal Strength at < 0.1% PER	P _{RX_MAX}			0		dBm

Electrical Characteristics (continued)

(All specifications and characteristics apply across the entire operating conditions range unless otherwise noted.)

PARAMETER	SYMBOL	CONDITIONS		MIN	TYP	MAX	UNITS
Receiver Sensitivity, Ideal Transmitter	P _{SENS_IT}	Measured with 37-byte payload	1Mbps Bluetooth LE		-97		dBm
			2Mbps Bluetooth LE		-94		
Receiver Sensitivity, Dirty Transmitter	P _{SENS_DT}	Measured with 37-byte payload	1Mbps Bluetooth LE		-95.5		dBm
			2Mbps Bluetooth LE		-93		
Receiver Sensitivity, Long-Range Coded	P _{SENS_LR}	Measured with 37-byte payload	125kbps Bluetooth LE		-105		dBm
			500kbps Bluetooth LE		-101		
C/I Cochannel	C/I _{1MHz}	1Mbps Bluetooth LE			6.7		dB
	C/I _{2MHz}	2Mbps Bluetooth LE			7		
Adjacent Interference	C/I _{+1_1}	+1MHz offset, 1Mbps Bluetooth LE			-2.5		dB
	C/I _{-1_1}	-1MHz offset, 1Mbps Bluetooth LE			-2.6		
	C/I _{+2_1}	+2MHz offset, 1Mbps Bluetooth LE			-22		
	C/I _{-2_1}	-2MHz offset, 1Mbps Bluetooth LE			-24		
	C/I _{+2_2}	+2MHz offset, 2Mbps Bluetooth LE			-2		
	C/I _{-2_2}	-2MHz offset, 2Mbps Bluetooth LE			-3		
	C/I _{+4_2}	+4MHz offset, 2Mbps Bluetooth LE			-32		
	C/I _{-4_2}	-4MHz offset, 2Mbps Bluetooth LE			-34		
Adjacent Interference, (3+n) MHz Offset [n = 0, 1, 2, . . .]	C/I _{3+MHZ}	1Mbps Bluetooth LE			-34.5		dB
Adjacent Interference, (6+2n) MHz Offset [n = 0, 1, 2, . . .]	C/I _{6+MHZ}	2Mbps Bluetooth LE			-34		dB
Intermodulation Performance, 1Mbps Bluetooth LE with 3MHz, 4MHz, 5MHz Offset	P _{IMD_1MBPS}	1Mbps Bluetooth LE			-38		dBm
Intermodulation Performance, 2Mbps Bluetooth LE with 6MHz, 8MHz, 10MHz Offset	P _{IMD_2MBPS}	2Mbps Bluetooth LE			-38		dBm
Received Signal Strength Indicator Accuracy	RSSI _{ACC}				±1.5		dB
Received Signal Strength Indicator Range	RSSI _{RANGE}				-100 to -15		dBm
ADC (SIGMA-DELTA)							
Resolution					10		Bits
ADC Clock Rate	f _{ACLK}			0.1		8	MHz

Electrical Characteristics (continued)

(All specifications and characteristics apply across the entire operating conditions range unless otherwise noted.)

PARAMETER	SYMBOL	CONDITIONS		MIN	TYP	MAX	UNITS
ADC Clock Period	t_{ACLK}			$1/f_{ACLK}$			μs
Input Voltage Range	V_{AIN}	AIN[7:0], ADC_DIVSEL = [00], ADC_CH_SEL = [7:0]	REF_SEL = 0, REF_SCALE = 0, SCALE = 0	$V_{SSA} +$ 0.05		V_{BG}	V
		AIN[7:0], ADC_DIVSEL = [01], ADC_CH_SEL = [7:0]	REF_SEL = 0, REF_SCALE = 0, SCALE = 1	$V_{SSA} +$ 0.05		$2 \times V_{BG}$	
		AIN[7:0], ADC_DIVSEL = [10], ADC_CH_SEL = [7:0]	REF_SEL = 1, REF_SCALE = 0, SCALE = 1, V_{DDIOH} selected as the I/O supply	$V_{SSA} +$ 0.05		V_{DDIOH}	
		AIN[7:0], ADC_DIVSEL = [11], ADC_CH_SEL = [7:0]	REF_SEL = 1, REF_SCALE = 0, SCALE = 1, V_{DDIO} selected as the I/O supply	$V_{SSA} +$ 0.05		V_{DDIO}	
Input Impedance	R_{AIN}			30			k Ω
Analog Input Capacitance	C_{AIN}	Fixed capacitance to V_{SSA}		1			pF
		Dynamically switched capacitance		250			fF
Integral Nonlinearity	INL	Measured at +25°C		± 2.5			LSb
Differential Nonlinearity	DNL	Measured at +25°C		± 1			LSb
Offset Error	V_{OS}			± 1			LSb
ADC Active Current	I_{ADC}	Measured at $V_{REG1} = 3.0V$, ADC active, reference buffer enabled, input buffer disabled		156			μA
ADC Setup Time	t_{ADC_SU}	Any power-up of ADC clock or ADC bias to CpuAdcStart		10			μs
ADC Output Latency	t_{ADC}			1067			t_{ACLK}
ADC Sample Rate	f_{ADC}			7.8			ksps
ADC Input Leakage	I_{ADC_LEAK}	ADC inactive or channel not selected		10			nA
Full-Scale Voltage	V_{FS}	ADC code = 0x3FF		1.2			V
Bandgap Temperature Coefficient	V_{TEMPCO}	Box method		30			ppm
COMPARATORS							
Input Offset Voltage	V_{OFFSET}			± 1			mV
Input Hysteresis	V_{HYST}	AINCOMPHYST[1:0] = 00		± 23			mV
		AINCOMPHYST[1:0] = 01		± 50			
		AINCOMPHYST[1:0] = 10		± 0			
		AINCOMPHYST[1:0] = 11		± 10			

Electrical Characteristics (continued)

(All specifications and characteristics apply across the entire operating conditions range unless otherwise noted.)

PARAMETER	SYMBOL	CONDITIONS	MIN	TYP	MAX	UNITS
Input Voltage Range	V_{IN_CMP}	Common-mode range. V_{DDIOH} selected as the I/O supply.	0.2		$V_{DDIOH} - 0.2V$	V
		Common-mode range. V_{DDIO} selected as the I/O supply.	0.2		$V_{DDIO} - 0.2V$	
FLASH MEMORY						
Flash Erase Time	t_{M_ERASE}	Mass erase		20		ms
	t_{P_ERASE}	Page erase		20		
Flash Programming Time per Word	t_{PROG}			42		μs
Flash Endurance			10			kcycles
Data Retention	t_{RET}	$T_A = +105^\circ C$	10			years
Current Consumption During Flash Programming	I_{PROG}	$V_{REGI} = 3.0V$. Current required for flash write/erase		4.6		mA

Electrical Characteristics—SPI

(Timing specifications are guaranteed by design and not production tested. All specifications and characteristics apply across the entire operating conditions range unless otherwise noted.)

PARAMETER	SYMBOL	CONDITIONS	MIN	TYP	MAX	UNITS
CONTROLLER MODE						
SPI Controller Operating Frequency for SPI0	f_{MCK0}	$f_{SYS_CLK} = 100MHz$, $f_{MCK0(MAX)} = f_{SYS_CLK}/2$, Mode 0 and Mode 2 operation, $SPI0_CTRL.sclk_fb_inv = 1$			50	MHz
		$f_{SYS_CLK} = 100MHz$, $f_{MCK0(MAX)} = f_{SYS_CLK}/4$, Mode 1 and Mode 3 operation			25	
SPI Controller Operating Frequency for SPI1	f_{MCK1}	$f_{SYS_CLK} = 100MHz$, $f_{MCK1(MAX)} = f_{SYS_CLK}/4$, all SPI modes of operation			25	MHz
SPI Controller SCK Period	t_{MCKX}			$1/f_{MCKX}$		ns
SCK Output Pulse-Width High/Low	t_{MCH} , t_{MCL}		$t_{MCKX}/2$			ns
MOSI Output Hold Time After SCK Sample Edge	t_{MOH}		$t_{MCX}/2$			ns
MOSI Output Valid to Sample Edge	t_{MOV}		$t_{MCKX}/2$			ns
MOSI Output Hold Time After SCK Low Idle	t_{MLH}			$t_{MCKX}/2$		ns
MISO Input Valid to SCK Sample Edge Setup	t_{MIS}			5		ns
MISO Input to SCK Sample Edge Hold	t_{MIH}			$t_{MCKX}/2$		ns

Electrical Characteristics—SPI (continued)

(Timing specifications are guaranteed by design and not production tested. All specifications and characteristics apply across the entire operating conditions range unless otherwise noted.)

PARAMETER	SYMBOL	CONDITIONS	MIN	TYP	MAX	UNITS
TARGET MODE						
SPI Target Operating Frequency	f_{SCK}				50	MHz
SPI Target SCK Period	t_{SCK}			$1/f_{SCK}$		ns
SCK Input Pulse-Width High/Low	t_{SCH}, t_{SCL}			$t_{SCK}/2$		
SSx Active to First Shift Edge	t_{SSE}			10		ns
MOSI Input to SCK Sample Edge Rise/Fall Setup	t_{SIS}			5		ns
MOSI Input from SCK Sample Edge Transition Hold	t_{SIH}			1		ns
MISO Output Valid After SCLK Shift Edge Transition	t_{SOV}			15		ns
SCK Inactive to SSx Inactive	t_{SSD}			10		ns
SSx Inactive Time	t_{SSH}			$1/f_{SCK}$		μ s
MISO Hold Time After SSx Deassertion	t_{SLH}			10		ns

Electrical Characteristics—I²C

(Timing specifications are guaranteed by design and not production tested. All specifications and characteristics apply across the entire operating conditions range unless otherwise noted.)

PARAMETER	SYMBOL	CONDITIONS	MIN	TYP	MAX	UNITS
STANDARD-MODE						
Output Fall Time	t_{OF}	Standard-mode, from $V_{IH(MIN)}$ to $V_{IL(MAX)}$		150		ns
SCL Clock Frequency	f_{SCL}		0		100	kHz
Low Period SCL Clock	t_{LOW}		4.7			μ s
High Time SCL Clock	t_{HIGH}		4.0			μ s
Setup Time for Repeated Start Condition	$t_{SU;STA}$		4.7			μ s
Hold Time for Repeated Start Condition	$t_{HD;STA}$		4.0			μ s
Data Setup Time	$t_{SU;DAT}$			300		ns
Data Hold Time	$t_{HD;DAT}$			10		ns
Rise Time for SDA and SCL	t_R			800		ns

Electrical Characteristics—I²C (continued)

(Timing specifications are guaranteed by design and not production tested. All specifications and characteristics apply across the entire operating conditions range unless otherwise noted.)

PARAMETER	SYMBOL	CONDITIONS	MIN	TYP	MAX	UNITS
Fall Time for SDA and SCL	t_F			200		ns
Setup Time for a Stop Condition	$t_{SU;STO}$		4.0			μ s
Bus Free Time Between a Stop and Start Condition	t_{BUS}		4.7			μ s
Data Valid Time	$t_{VD;DAT}$		3.45			μ s
Data Valid Acknowledge Time	$t_{VD;ACK}$		3.45			μ s
FAST-MODE						
Output Fall Time	t_{OF}	From $V_{IH(MIN)}$ to $V_{IL(MAX)}$		150		ns
Pulse Width Suppressed by Input Filter	t_{SP}			75		ns
SCL Clock Frequency	f_{SCL}		0		400	kHz
Low Period SCL Clock	t_{LOW}		1.3			μ s
High Time SCL Clock	t_{HIGH}		0.6			μ s
Setup Time for Repeated Start Condition	$t_{SU;STA}$		0.6			μ s
Hold Time for Repeated Start Condition	$t_{HD;STA}$		0.6			μ s
Data Setup Time	$t_{SU;DAT}$			125		ns
Data Hold Time	$t_{HD;DAT}$			10		ns
Rise Time for SDA and SCL	t_R			30		ns
Fall Time for SDA and SCL	t_F			30		ns
Setup Time for a Stop Condition	$t_{SU;STO}$		0.6			μ s
Bus Free Time Between a Stop and Start Condition	t_{BUS}		1.3			μ s
Data Valid Time	$t_{VD;DAT}$		0.9			μ s
Data Valid Acknowledge Time	$t_{VD;ACK}$		0.9			μ s
FAST-MODE PLUS						
Output Fall Time	t_{OF}	From $V_{IH(MIN)}$ to $V_{IL(MAX)}$		80		ns
Pulse Width Suppressed by Input Filter	t_{SP}			75		ns
SCL Clock Frequency	f_{SCL}		0		1000	kHz
Low Period SCL Clock	t_{LOW}		0.5			μ s
High Time SCL Clock	t_{HIGH}		0.26			μ s

Electrical Characteristics—I²C (continued)

(Timing specifications are guaranteed by design and not production tested. All specifications and characteristics apply across the entire operating conditions range unless otherwise noted.)

PARAMETER	SYMBOL	CONDITIONS	MIN	TYP	MAX	UNITS
Setup Time for Repeated Start Condition	$t_{SU;STA}$		0.26			μ s
Hold Time for Repeated Start Condition	$t_{HD;STA}$		0.26			μ s
Data Setup Time	$t_{SU;DAT}$			50		ns
Data Hold Time	$t_{HD;DAT}$			10		ns
Rise Time for SDA and SCL	t_R			50		ns
Fall Time for SDA and SCL	t_F			30		ns
Setup Time for a Stop Condition	$t_{SU;STO}$		0.26			μ s
Bus Free Time Between a Stop and Start Condition	t_{BUS}		0.5			μ s
Data Valid Time	$t_{VD;DAT}$		0.45			μ s
Data Valid Acknowledge Time	$t_{VD;ACK}$		0.45			μ s

Electrical Characteristics—I²S

(Timing specifications are guaranteed by design and not production tested. All specifications and characteristics apply across the entire operating conditions range unless otherwise noted.)

PARAMETER	SYMBOL	CONDITIONS	MIN	TYP	MAX	UNITS
Bit Clock Frequency	f_{BCLK}				25	MHz
BCLK High Time	t_{WBCLKH}			$0.5 \times 1/f_{BCLK}$		ns
BCLK Low Time	t_{WBCLKL}			$0.5 \times 1/f_{BCLK}$		ns
LRCLK Setup Time	t_{LRCLK_BLCKS}			25		ns
Delay Time, BCLK to SD (Output) Valid	t_{BCLK_SDO}			12		ns
Setup Time for SD (Input)	t_{SU_SDI}			6		ns
Hold Time SD (Input)	t_{HD_SDI}			3		ns

Electrical Characteristics—1-Wire Controller

(Timing specifications are guaranteed by design and not production tested. All specifications and characteristics apply across the entire operating conditions range unless otherwise noted.)

PARAMETER	SYMBOL	CONDITIONS	MIN	TYP	MAX	UNITS
Write 0 Low Time	t_{W0L}	Standard		60		μ s
		Overdrive		8		

Electrical Characteristics—1-Wire Controller (continued)

(Timing specifications are guaranteed by design and not production tested. All specifications and characteristics apply across the entire operating conditions range unless otherwise noted.)

PARAMETER	SYMBOL	CONDITIONS	MIN	TYP	MAX	UNITS
Write 1 Low Time	t_{W1L}	Standard		6		μs
		Standard, Long Line mode		8		
		Overdrive		1		
Presence Detect Sample	t_{MSP}	Standard		70		μs
		Standard, Long Line mode		85		
		Overdrive		9		
Read Data Value	t_{MSR}	Standard		15		μs
		Standard, Long Line mode		24		
		Overdrive		3		
Recovery Time	t_{REC0}	Standard		10		μs
		Standard, Long Line mode		20		
		Overdrive		4		
Reset Time High	t_{RSTH}	Standard		480		μs
		Overdrive		58		
Reset Time Low	t_{RSTL}	Standard		600		μs
		Overdrive		70		
Time Slot	t_{SLOT}	Standard		70		μs
		Overdrive		12		

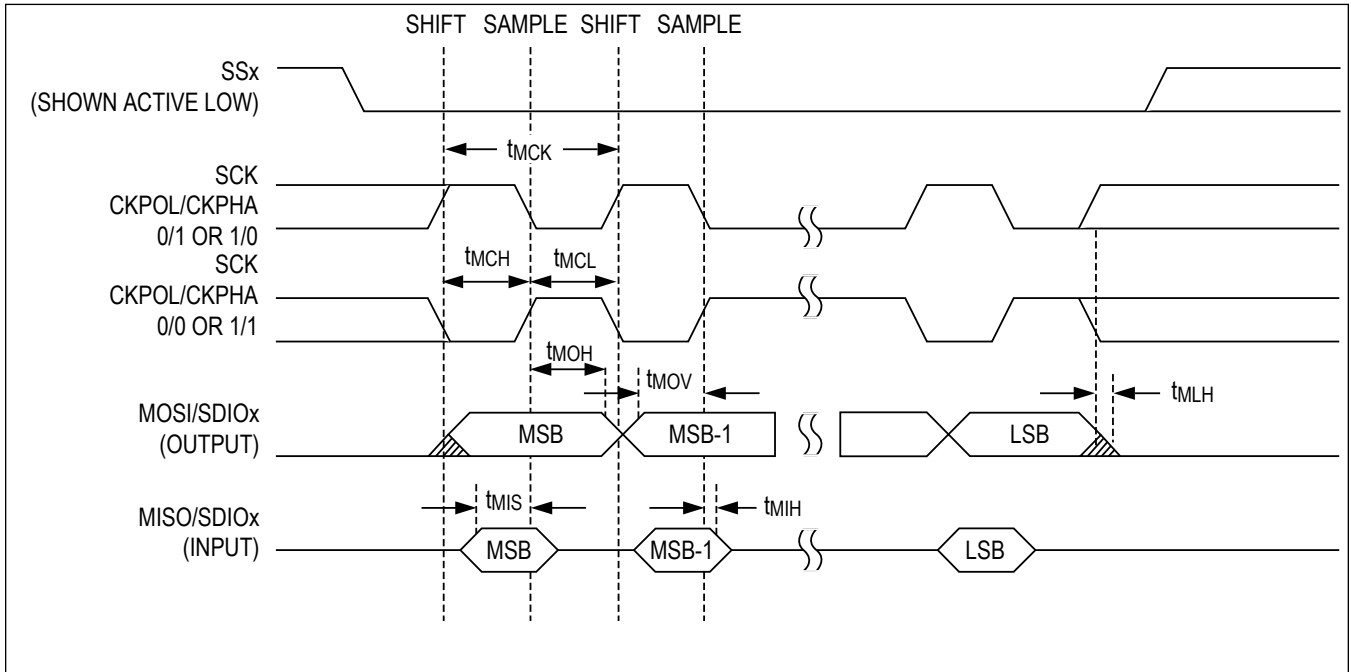

Figure 3. SPI Controller Mode Timing Diagram

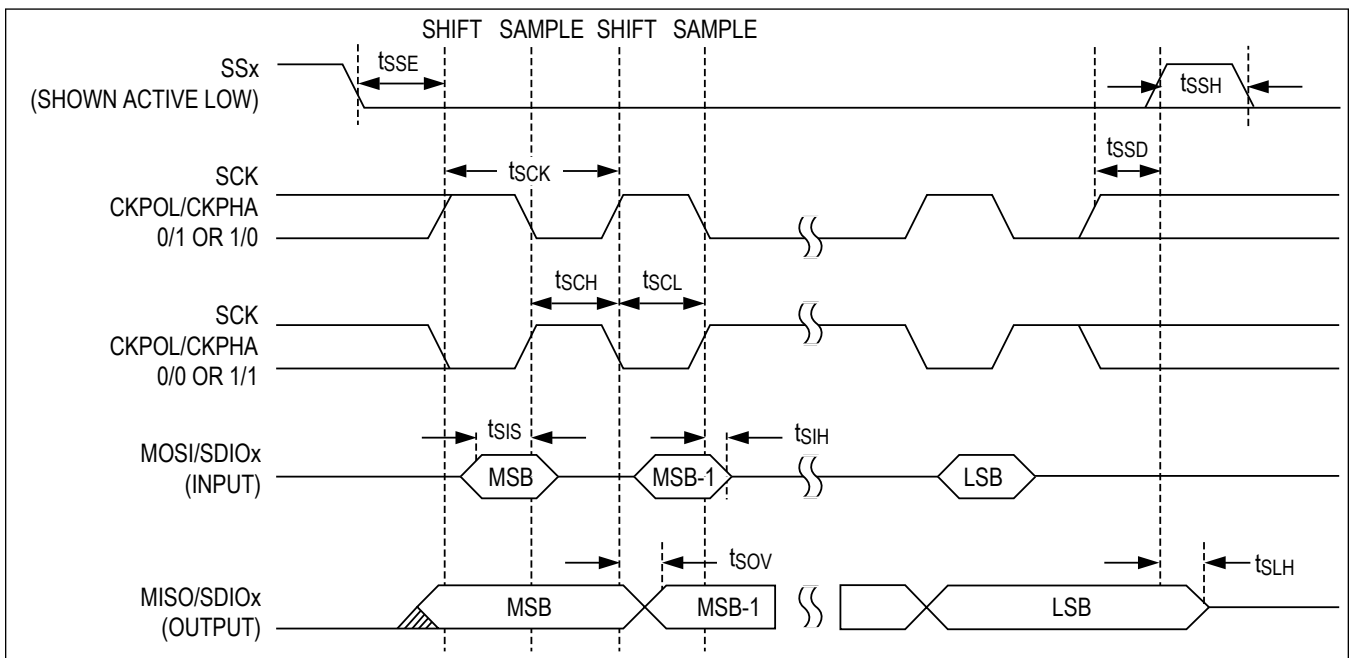

Figure 4. SPI Target Mode Timing Diagram

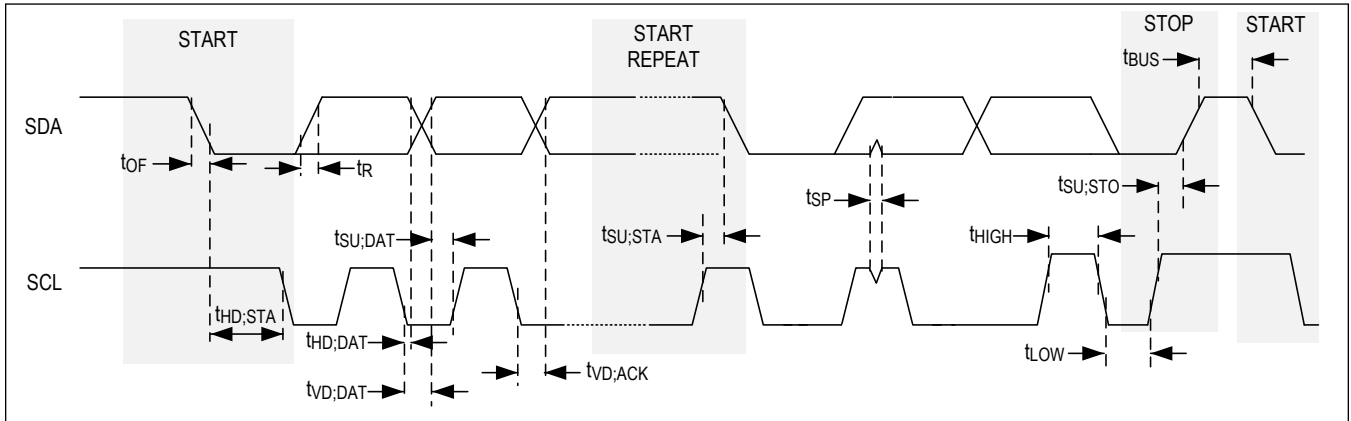

Figure 5. I²C Timing Diagram

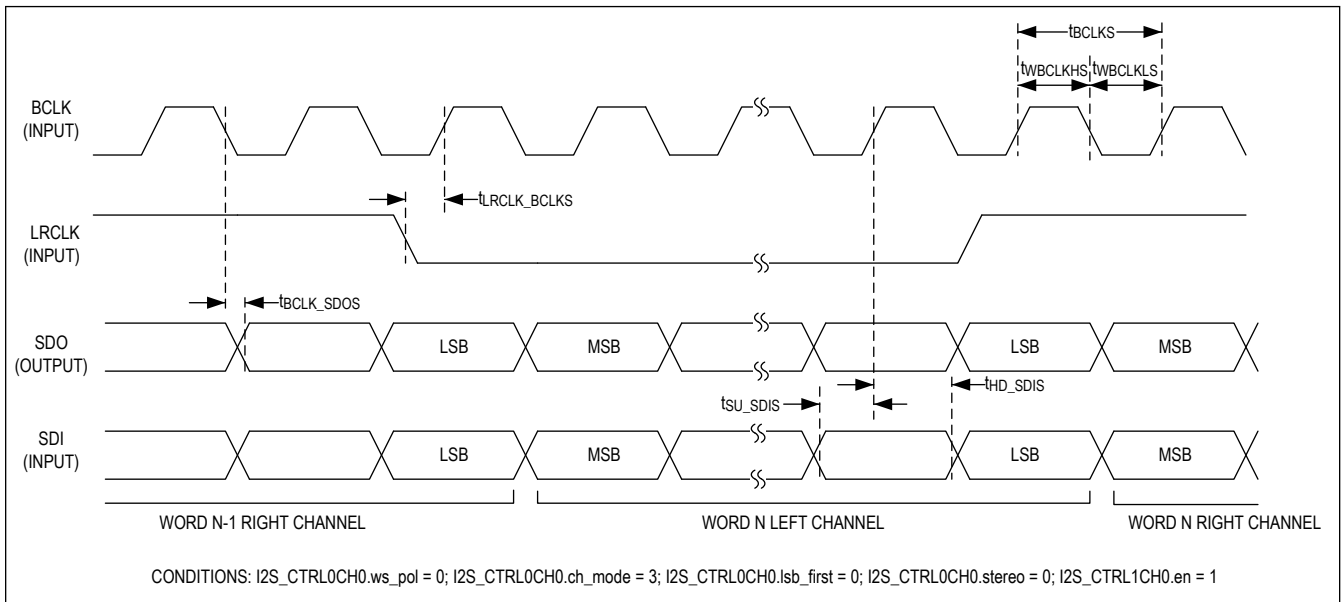

Figure 6. I²S Target Timing Diagram

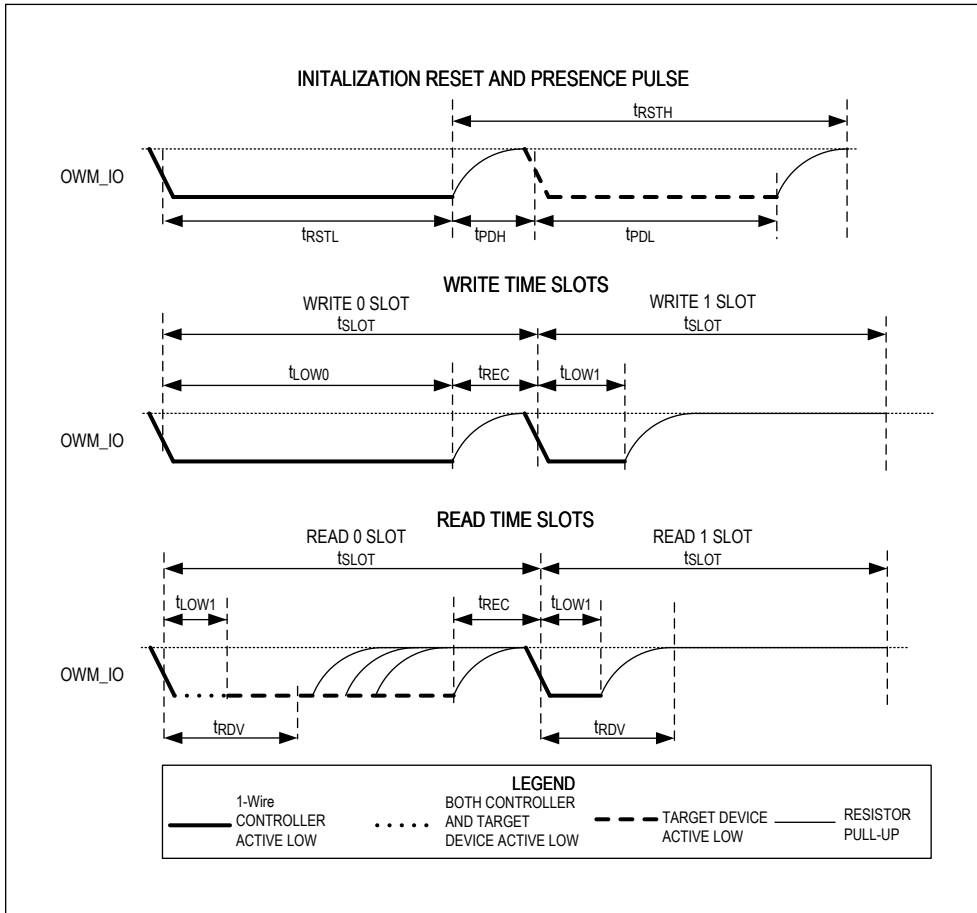
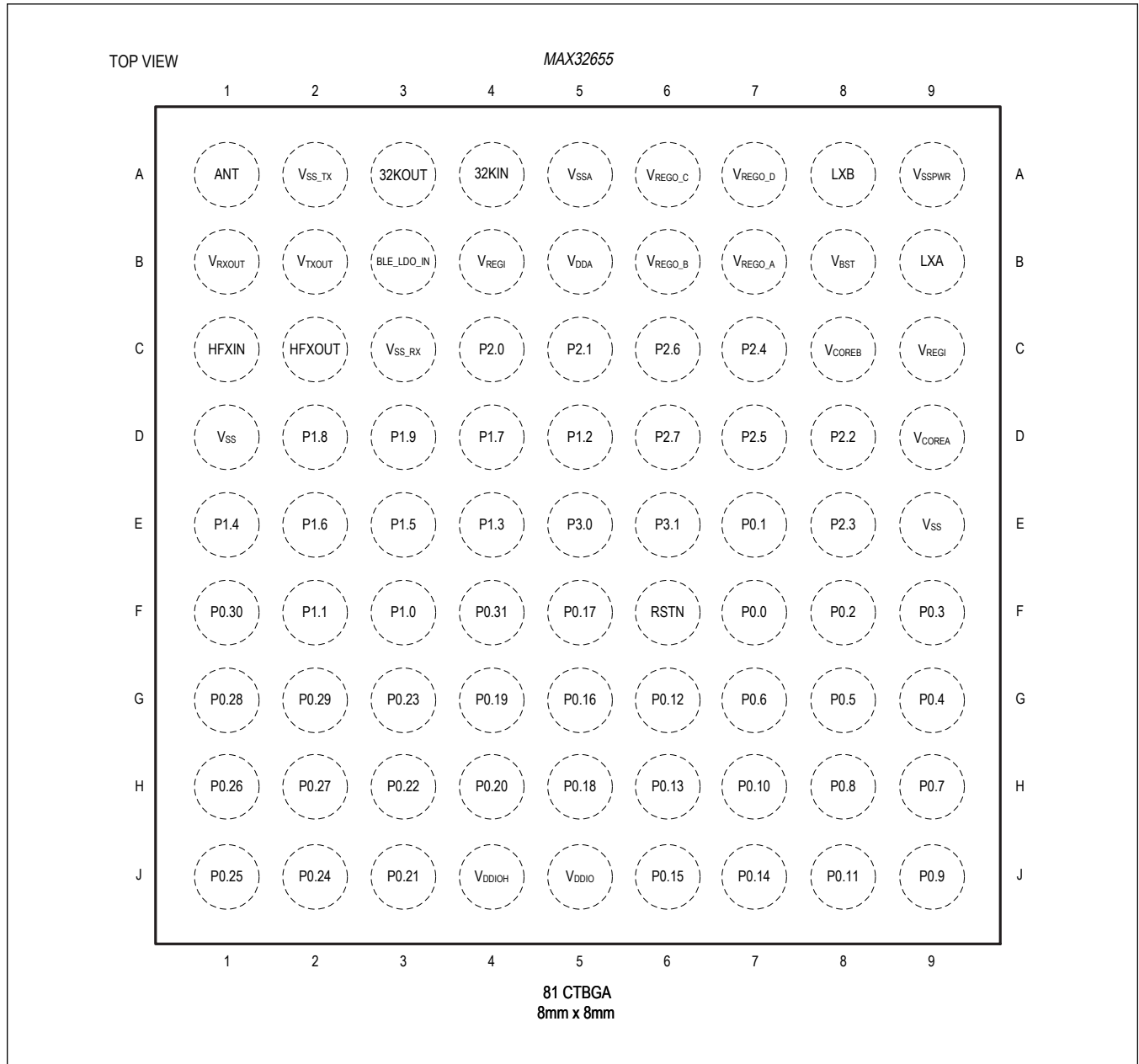

Figure 7. 1-Wire Controller Data Timing Diagram

Pin Configuration

81 CTBGA



Pin Descriptions – 81 CTBGA

PIN	NAME	FUNCTION MODE			FUNCTION
		Primary Signal (Default)	Alternate Function 1	Alternate Function 2	
POWER (See the Applications Information section for bypass capacitor recommendations.)					
C9, B4	V _{REGI}	—	—	—	Battery Power Supply for the SIMO Switch-Mode Power Supply (SMPS). See V_{REGI} Design Considerations and Device PCB Power Connectivity .
B3	BLE_LDO_IN	—	—	—	Bluetooth LDO Input. Bypass BLE_LDO_IN with a 1µF capacitor to V _{SS} placed as close as possible to the BLE_LDO_IN device pin. This device pin must be connected as shown in Device PCB Power Connectivity , even if Bluetooth functionality is not desired for the application.
B5	V _{DDA}	—	—	—	1.8V Analog Power Supply. Bypass with 1µF to V _{SS} . This device pin must be connected as shown in Device PCB Power Connectivity .
D9	V _{COREA}	—	—	—	Digital Core Supply Voltage A. V _{COREA} must be greater than or equal to V _{COREB} . Bypass with 1µF to V _{SS} . This device pin must be connected as shown in Device PCB Power Connectivity .
C8	V _{COREB}	—	—	—	Digital Core Supply Voltage B. V _{COREA} must be greater than or equal to V _{COREB} . Bypass with 1µF to V _{SS} . This device pin must be connected as shown in Device PCB Power Connectivity .
B1	V _{RXOUT}	—	—	—	Bluetooth Radio Baseband Supply Voltage Output. Bypass this pin to V _{SS_RX} with a 1µF capacitor close to the package. Do not connect any other signal to this device pin.
B2	V _{TXOUT}	—	—	—	Bluetooth Radio RF Supply Voltage Output. Bypass this pin to V _{SS_TX} with a 1µF capacitor close to the package. Do not connect any other signal to this device pin.
B8	V _{BST}	—	—	—	The boosted supply voltage for the gate drive of high-side switches. This device pin must be connected as shown in Device PCB Power Connectivity .
B7	V _{REGO_A}	—	—	—	Buck Converter A Voltage Output. Bypass V _{REGO_A} with a 22µF capacitor to V _{SS} placed as close as possible to the V _{REGO_A} device pin. This device pin must be connected as shown in Device PCB Power Connectivity . Do not connect any other signal to this device pin.
B6	V _{REGO_B}	—	—	—	Buck Converter B Voltage Output. Bypass V _{REGO_B} with a 22µF capacitor to V _{SS} placed as close as possible to the V _{REGO_B} device pin. This device pin must be connected as shown in Device PCB Power Connectivity . Do not connect any other signal to this device pin.

81 CTBGA

PIN	NAME	FUNCTION MODE			FUNCTION
		Primary Signal (Default)	Alternate Function 1	Alternate Function 2	
A6	VREGO_C	—	—	—	Buck Converter C Voltage Output. Bypass VREGO_C with a 22µF capacitor to VSS placed as close as possible to the VREGO_C device pin. This device pin must be connected as shown in Device PCB Power Connectivity . Do not connect any other signals to this device pin.
A7	VREGO_D	—	—	—	Buck Converter D Voltage Output. Bypass VREGO_D with a 22µF capacitor to VSS placed as close as possible to the VREGO_D device pin. This device pin must be connected as shown in Device PCB Power Connectivity . Do not connect any other signal to this device pin.
J5	VDDIO	—	—	—	GPIO Supply Voltage. VDDIOH must be greater than VDDIO. Bypass this device pin to VSS with a 1µF capacitor placed as close to the package as possible. This device pin must be connected as shown in Device PCB Power Connectivity .
J4	VDDIOH	—	—	—	GPIO Supply Voltage, High. VDDIOH must be greater than VDDIO. Bypass this device pin to VSS with a 1µF capacitor placed as close to the package as possible. This device pin must be connected as shown in Device PCB Power Connectivity . Do not connect any other signal to this device pin.
D1, E9	VSS	—	—	—	Digital Ground
A5	VSSA	—	—	—	Analog Ground
A9	VSSPWR	—	—	—	Ground for the SIMO SMPS. See VREGI Design Considerations .
C3	VSS_RX	—	—	—	Bluetooth Radio Baseband Ground
A2	VSS_TX	—	—	—	Bluetooth Radio RF Ground
B9	LXA	—	—	—	Switching Inductor Input A. Connect a 2.2µH inductor between LXA and LXB. See Device PCB Power Connectivity .
A8	LXB	—	—	—	Switching Inductor Input B. Connect a 2.2µH inductor between LXA and LXB. See Device PCB Power Connectivity .
RESET AND CONTROL					
F6	RSTN	—	—	—	External System Reset Input (Active-Low). The device remains in reset while this pin is in its active state. When the pin transitions to its inactive state, the device performs a system reset and executes the first instruction. This pin has an internal pull-up to the VDDIOH supply.

81 CTBGA

PIN	NAME	FUNCTION MODE			FUNCTION
		Primary Signal (Default)	Alternate Function 1	Alternate Function 2	
CLOCK					
A3	32KOUT	—	—	—	32kHz Crystal Oscillator Output. Connect a 32kHz crystal between 32KIN and 32KOUT for RTC operation. If the RTC is unused, and a crystal is not connected, do not connect this device pin.
A4	32KIN	—	—	—	32kHz Crystal Oscillator Input. Connect a 32kHz crystal between 32KIN and 32KOUT for RTC operation. Optionally, this pin can be configured as the input for an external CMOS-level clock source. Load capacitors are not required. If the RTC is unused, and a crystal is not connected, connect this device pin to V _{SS} through a 1kΩ resistor. See External RTC Oscillator (ERTCO) in the Electrical Characteristics table and RTC Crystal Guidelines for more information.
C2	HFXOUT	—	—	—	32MHz Crystal Oscillator Output. When this device pin is not used, do not connect.
C1	HFXIN	—	—	—	32MHz Crystal Oscillator Input. Connect a 32MHz crystal between HFXIN and HFXOUT for Bluetooth operation or I ² S controller operation. During the optional kick-start operation, a series of pulses is output on this device pin to stimulate the crystal. If the 32MHz crystal is not in use and is not connected, connect the device pin to V _{SS} through a 10kΩ resistor.
GPIO AND ALTERNATE FUNCTION					
F7	P0.0	P0.0	UART0A_RX	—	UART0 Receive Port Map A
E7	P0.1	P0.1	UART0A_TX	—	UART0 Transmit Port Map A
F8	P0.2	P0.2	TMR0A_IOA	UART0B_CTS	Timer 0 I/O 32 Bits or Lower 16 Bits Port Map A; UART0 Clear to Send Port Map B
F9	P0.3	P0.3	EXT_CLK/ TMR0A_IOB	UART0B_RTS	External Clock for Use as SYS_OSC/Timer 0 I/O Upper 16 Bits Port Map A; UART0 Request to Send Port Map B
G9	P0.4	P0.4	SPI0_SS0	TMR0B_IOAN	SPI0 Target Select 0; Timer 0 Inverted Output Port Map B
G8	P0.5	P0.5	SPI0_MOSI	TMR0B_IOBN	SP0 Controller Out Target In Serial Data 0; 32-Bit Timer 0 Inverted Output Upper 16 Bits Port Map B
G7	P0.6	P0.6	SPI0_MISO	OWM_IO	SPI0 Controller In Target Out Serial Data 1; 1-Wire Controller Data I/O
H9	P0.7	P0.7	SPI0_SCK	OWM_PE	SPI0 Clock; 1-Wire Controller Pull-up Enable Output
H8	P0.8	P0.8	SPI0_SDIO2	TMR0B_IOA	SPI0 Data 2 I/O; Timer 0 I/O 32 Bits or Lower 16 Bits Port Map B
J9	P0.9	P0.9	SPI0_SDIO3	TMR0B_IOB	SPI0 Data 3 I/O; Timer 0 I/O Upper 16 Bits Port Map B
H7	P0.10	P0.10	I2C0_SCL	SPI0_SS2	I2C0 Clock; SPI0 Target Select 2

81 CTBGA

PIN	NAME	FUNCTION MODE			FUNCTION
		Primary Signal (Default)	Alternate Function 1	Alternate Function 2	
J8	P0.11	P0.11	I2C0_SDA	SPI0_SS1	I2C0 Serial Data; SPI0 Target Select 1
G6	P0.12	P0.12	UART1A_RX	TMR1B_IOAN	UART1 Receive Port Map A; Timer 1 Inverted Output Port Map B
H6	P0.13	P0.13	UART1A_TX	TMR1B_IOBN	UART1 Transmit Port Map A; Timer 1 Inverted Output Upper 16 Bits Port Map B
J7	P0.14	P0.14	TMR1A_IOA	UART1B_CTS	Timer 1 I/O 32 Bits or Lower 16 Bits Port Map A; UART1 Clear to Send Port Map B
J6	P0.15	P0.15	TMR1A_IOB	UART1B_RTS	Timer 1 I/O Upper 16 Bits Port Map A; UART1 Request to Send Port Map B
G5	P0.16	P0.16	I2C1_SCL	PT2	I2C1 Clock; Pulse Train 2
F5	P0.17	P0.17	I2C1_SDA	PT3	I2C1 Serial Data; Pulse Train 3
H5	P0.18	P0.18	PT0	OWM_IO	Pulse Train 0; 1-Wire Controller Data I/O
G4	P0.19	P0.19	PT1	OWM_PE	Pulse Train 1; 1-Wire Controller Pull-up Enable Output
H4	P0.20	P0.20	SPI1_SS0	TMR1B_IOA	SPI1 Target Select 0; Timer 1 I/O 32 Bits or Lower 16 Bits Port Map B
J3	P0.21	P0.21	SPI1_MOSI	TMR1B_IOB	SPI1 Controller Out Target In Serial Data 0; Timer 1 I/O Upper 16 Bits Port Map B
H3	P0.22	P0.22	SPI1_MISO	TMR1B_IOAN	SPI1 Controller In Target Out Serial Data 1; Timer 1 Inverted Output Port Map B
G3	P0.23	P0.23	SPI1_SCK	TMR1B_IOBN	SPI1 Clock; Timer 1 Inverted Output Upper 16 Bits Port Map B
J2	P0.24	P0.24	SPI1_SDIO2	TMR2B_IOA	SPI1 Data 2; Timer 2 I/O 32 Bits or Lower 16 Bits Port Map B
J1	P0.25	P0.25	SPI1_SDIO3	TMR2B_IOB	SPI1 Data 3; Timer 2 I/O Upper 16 Bits Port Map B
H1	P0.26	P0.26	TMR2A_IOA	SPI1_SS1	Timer 2 I/O 32 Bits or Lower 16 Bits Port Map A; SPI1 Target Select 1
H2	P0.27	P0.27	TMR2A_IOB	SPI1_SS2	Timer 2 I/O Upper 16 Bits Port Map A; SPI1 Target Select 2
G1	P0.28	SWDIO	SWDIO	—	Serial Wire Debug Data I/O
G2	P0.29	SWCLK	SWCLK	—	Serial Wire Debug Clock
F1	P0.30	P0.30	I2C2_SCL	UART2B_CTS	I2C2 Clock; UART2 Clear to Send Port Map B
F4	P0.31	P0.31	I2C2_SDA	UART2B_RTS	I2C2 Serial Data; UART2 Request to Send Port Map B
F3	P1.0	P1.0	UART2A_RX	RV_TCK	UART2 Receive Port Map A; 32-Bit RISC-V Test Port Clock
F2	P1.1	P1.1	UART2A_TX	RV_TMS	UART2 Transmit Port Map A; 32-Bit RISC-V Test Port Select
D5	P1.2	P1.2	I2S_SCK	RV_TDI	I2S Bit Clock; 32-Bit RISC-V Test Port Data Input
E4	P1.3	P1.3	I2S_WS	RV_TDO	I2S Left/Right Clock; 32-Bit RISC-V Test Port Data Output

81 CTBGA

PIN	NAME	FUNCTION MODE			FUNCTION
		Primary Signal (Default)	Alternate Function 1	Alternate Function 2	
E1	P1.4	P1.4	I2S_SDI	TMR3B_IOA	I ² S Serial Data Input; Timer 3 I/O 32 Bits or Lower 16 Bits Port Map B
E3	P1.5	P1.5	I2S_SDO	TMR3B_IOB	I ² S Serial Data Output; Timer 3 I/O Upper 16 Bits Port Map B
E2	P1.6	P1.6	TMR3A_IOA	BLE_ANT_CTR_L2	Timer 3 I/O 32 Bits or Lower 16 Bits Port Map A; Bluetooth Antenna Control Line 2
D4	P1.7	P1.7	TMR3A_IOB	BLE_ANT_CTR_L3	Timer 3 I/O Upper 16 Bits Port Map A; Bluetooth Antenna Control Line 3
D2	P1.8	P1.8	BLE_ANT_CTR_L0	RXEVO	Bluetooth Antenna Control Line 0; CM4 Rx Event Input
D3	P1.9	P1.9	BLE_ANT_CTR_L1	TXEVO	Bluetooth Antenna Control Line 1; CM4 Tx Event Output
C4	P2.0	P2.0	AIN0/AIN0N	—	Analog-to-Digital Converter Input 0/Comparator 0 Negative Input
C5	P2.1	P2.1	AIN1/AIN0P	—	Analog-to-Digital Converter Input 1/Comparator 0 Positive Input
D8	P2.2	P2.2	AIN2/AIN1N	—	Analog-to-Digital Converter Input 2/Comparator 1 Negative Input
E8	P2.3	P2.3	AIN3/AIN1P	—	Analog-to-Digital Converter Input 3/Comparator 1 Positive Input
C7	P2.4	P2.4	AIN4/AIN2N	LPTMR0B_IOA	Analog-to-Digital Converter Input 4/Comparator 2 Negative Input; Low-Power Timer 0 I/O Port Map B
D7	P2.5	P2.5	AIN5/AIN2P	LPTMR1B_IOA	Analog-to-Digital Converter Input 5/Comparator 2 Positive Input; Low-Power Timer 1 I/O Port Map B
C6	P2.6	P2.6	LPTMR0_CLK/AIN6/AIN3N	LPUARTB_RX	Low-Power Timer 0 External Clock Input/ Analog-to-Digital Converter Input 6/Comparator 3 Negative Input; Low-Power UART 0 Receive Port Map B
D6	P2.7	P2.7	LPTMR1_CLK/AIN7/AIN3P	LPUARTB_TX	Low-Power Timer 1 External Clock Input/ Analog-to-Digital Converter Input 7/Comparator 3 Positive Input; Low-Power UART Transmit Port Map B
E5	P3.0	P3.0	PDOWN	—	Power-Down Output. Internally pulled down to V _{SS} . This device pin can only be powered by V _{DDIOH} . Can be used as a WAKE-UP source.
E6	P3.1	P3.1	SQWOUT	—	Square-Wave Output. Internally pulled down to V _{SS} . This device pin can only be powered by V _{DDIOH} .
ANTENNA OUTPUT					
A1	ANT	—	—	—	Antenna for Bluetooth Radio. Attach the single-ended, unbalanced Bluetooth radio antenna. If Bluetooth functionality is not used, and there is no antenna connected, do not connect this device pin.

Pin Configuration

51 WLP

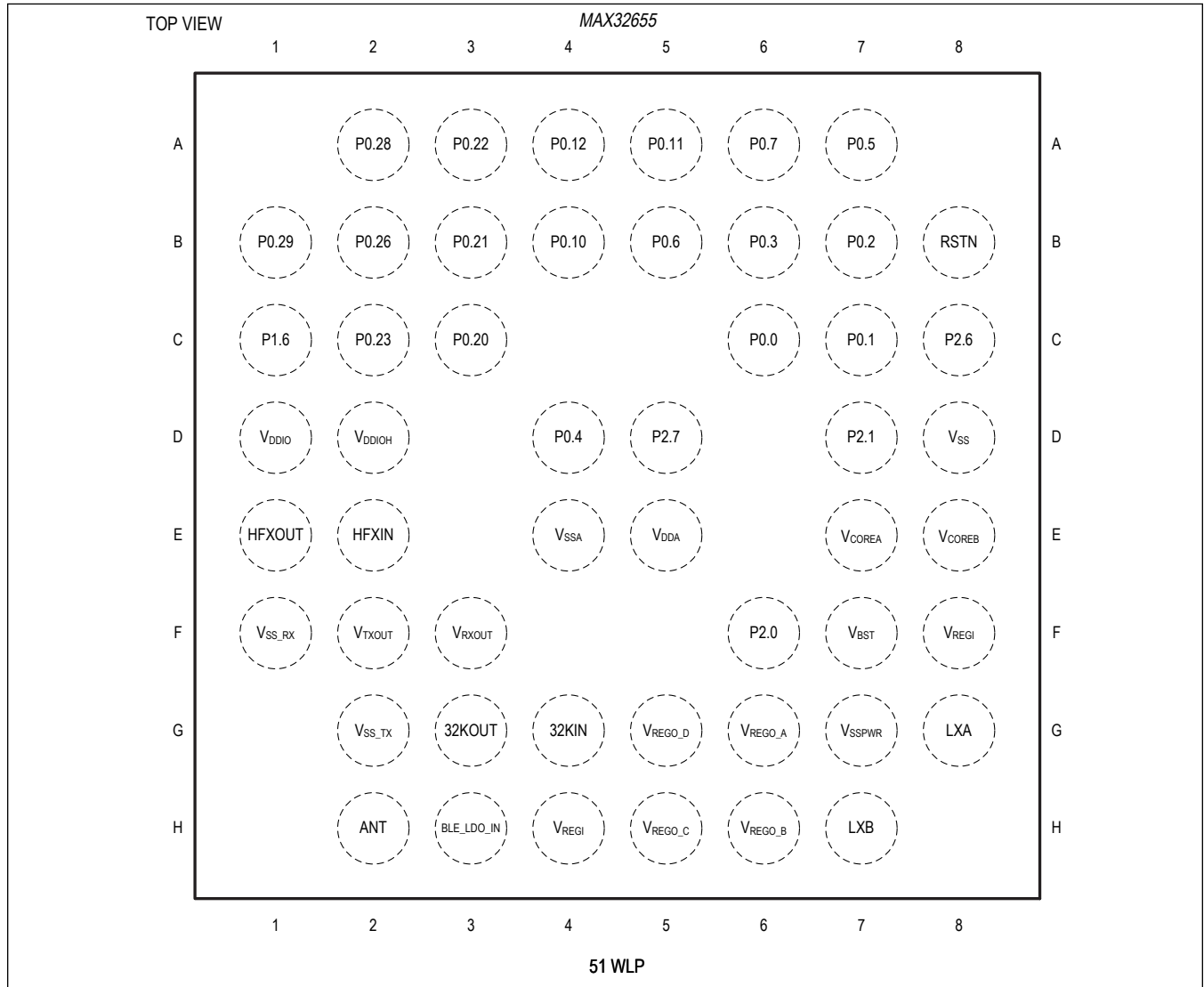

Pin Descriptions – 51 WLP

PIN	NAME	FUNCTION MODE			FUNCTION
		Primary Signal (Default)	Alternate Function 1	Alternate Function 2	
POWER (See the Applications Information section for bypass capacitor recommendations.)					
F8, H4	VREGI	—	—	—	Battery Power Supply for the SIMO Switch-Mode Power Supply (SMPS). See VREGI Design Considerations and Device PCB Power Connectivity .

51 WLP

PIN	NAME	FUNCTION MODE			FUNCTION
		Primary Signal (Default)	Alternate Function 1	Alternate Function 2	
H3	BLE_LDO_IN	—	—	—	Bluetooth LDO Input. Bypass BLE_LDO_IN with a 1 μ F capacitor to V _{SS} placed as close as possible to the BLE_LDO_IN device pin. This device pin must be connected as shown in Device PCB Power Connectivity , even if Bluetooth functionality is not desired for the application.
E5	V _{DDA}	—	—	—	1.8V Analog Power Supply. Bypass with 1 μ F to V _{SS} . This device pin must be connected as shown in Device PCB Power Connectivity .
E7	V _{COREA}	—	—	—	Digital Core Supply Voltage A. V _{COREA} must be greater than or equal to V _{COREB} . Bypass with 1 μ F to V _{SS} . This device pin must be connected as shown in Device PCB Power Connectivity .
E8	V _{COREB}	—	—	—	Digital Core Supply Voltage B. V _{COREA} must be greater than or equal to V _{COREB} . Bypass with 1 μ F to V _{SS} . This device pin must be connected as shown in Device PCB Power Connectivity .
F3	V _{RXOUT}	—	—	—	Bluetooth Radio Baseband Supply Voltage Output. Bypass this pin to V _{SS_RX} with a 1 μ F capacitor close to the package. Do not connect any other signal to this device pin.
F2	V _{TXOUT}	—	—	—	Bluetooth Radio RF Supply Voltage Output. Bypass this pin to V _{SS_TX} with a 1 μ F capacitor close to the package. Do not connect any other signal to this device pin.
F7	V _{BST}	—	—	—	The boosted supply voltage for the gate drive of high-side switches. This device pin must be connected as shown in Device PCB Power Connectivity .
G6	V _{REGO_A}	—	—	—	Buck Converter A Voltage Output. Bypass V _{REGO_A} with a 22 μ F capacitor to V _{SS} placed as close as possible to the V _{REGO_A} device pin. This device pin must be connected as shown in Device PCB Power Connectivity . Do not connect any other signal to this device pin.
H6	V _{REGO_B}	—	—	—	Buck Converter B Voltage Output. Bypass V _{REGO_B} with a 22 μ F capacitor to V _{SS} placed as close as possible to the V _{REGO_B} device pin. This device pin must be connected as shown in Device PCB Power Connectivity . Do not connect any other signal to this device pin.
H5	V _{REGO_C}	—	—	—	Buck Converter C Voltage Output. Bypass V _{REGO_C} with a 22 μ F capacitor to V _{SS} placed as close as possible to the V _{REGO_C} device pin. This device pin must be connected as shown in Device PCB Power Connectivity . Do not connect any other signal to this device pin.

51 WLP

PIN	NAME	FUNCTION MODE			FUNCTION
		Primary Signal (Default)	Alternate Function 1	Alternate Function 2	
G5	VREGO_D	—	—	—	Buck Converter D Voltage Output. Bypass VREGO_D with a 22µF capacitor to VSS placed as close as possible to the VREGO_D device pin. This device pin must be connected as shown in Device PCB Power Connectivity . Do not connect any other signal to this device pin.
D1	VDDIO	—	—	—	GPIO Supply Voltage. VDDIOH must be greater than VDDIO. Bypass this device pin to VSS with a 1µF capacitor placed as close to the package as possible. This device pin must be connected as shown in Device PCB Power Connectivity .
D2	VDDIOH	—	—	—	GPIO Supply Voltage, High. VDDIOH must be greater than VDDIO. Bypass this device pin to VSS with a 1µF capacitor placed as close to the package as possible. This device pin must be connected as shown in Device PCB Power Connectivity .
D8	VSS	—	—	—	Digital Ground
E4	VSSA	—	—	—	Analog Ground
G7	VSSPWR	—	—	—	Ground for the SIMO SMPS. See VREGI Design Considerations .
F1	VSS_RX	—	—	—	Bluetooth Radio Baseband Ground
G2	VSS_TX	—	—	—	Bluetooth Radio RF Ground
G8	LXA	—	—	—	Switching Inductor Input A. Connect a 2.2µH inductor between LXA and LXB. See Device PCB Power Connectivity .
H7	LXB	—	—	—	Switching Inductor Input B. Connect a 2.2µH inductor between LXA and LXB. See Device PCB Power Connectivity .
RESET AND CONTROL					
B8	RSTN	—	—	—	External System Reset Input (Active-Low). The device remains in reset while this pin is in its active state. When the pin transitions to its inactive state, the device performs a system reset and executes the first instruction. This pin has an internal pull-up to the VDDIOH supply.
CLOCK					
G3	32KOUT	—	—	—	32kHz Crystal Oscillator Output. Connect a 32kHz crystal between 32KIN and 32KOUT for RTC operation. If the RTC is unused, and a crystal is not connected, do not connect this device pin.

51 WLP

PIN	NAME	FUNCTION MODE			FUNCTION
		Primary Signal (Default)	Alternate Function 1	Alternate Function 2	
G4	32KIN	—	—	—	32kHz Crystal Oscillator Input. Connect a 32kHz crystal between 32KIN and 32KOUT for RTC operation. Optionally, this pin can be configured as the input for an external CMOS-level clock source. Load capacitors are not required. If the RTC is unused, and a crystal is not connected, connect this device pin to V _{SS} through a 1kΩ resistor. See External RTC Oscillator (ERTCO) in the Electrical Characteristics table and RTC Crystal Guidelines for more information.
E1	HFXOUT	—	—	—	32MHz Crystal Oscillator Output. When this device pin is not used, do not connect.
E2	HFXIN	—	—	—	32MHz Crystal Oscillator Input. Connect a 32MHz crystal between HFXIN and HFXOUT for Bluetooth operation. During the optional kick-start operation, a series of pulses is output on this device pin to stimulate the crystal. If the 32MHz crystal is not in use and is not connected, connect the device pin to V _{SS} through a 10kΩ resistor.
GPIO AND ALTERNATE FUNCTION (See the Applications Information section for GPIO and Alternate Function Matrices.)					
C6	P0.0	P0.0	UART0A_RX	—	UART0 Receive Port Map A
C7	P0.1	P0.1	UART0A_TX	—	UART0 Transmit Port Map A
B7	P0.2	P0.2	TMR0A_IOA	UART0B_CTS	Timer 0 I/O 32 Bits or Lower 16 Bits Port Map A; UART0 Clear to Send Port Map B
B6	P0.3	P0.3	EXT_CLK/ TMR0A_IOB	UART0B_RTS	External Clock for Use as SYS_OSC/Timer 0 I/O Upper 16 Bits Port Map A; UART0 Request to Send Port Map B
D4	P0.4	P0.4	SPI0_SS0	TMR0B_IOAN	SPI0 Target Select 0; Timer 0 Inverted Output Port Map B
A7	P0.5	P0.5	SPI0_MOSI	TMR0B_IOBN	SPI0 Controller Out Target In Serial Data 0; 32-Bit Timer 0 Inverted Output Upper 16 Bits Port Map B
B5	P0.6	P0.6	SPI0_MISO	OWM_IO	SPI0 Controller In Target Out Serial Data 1; 1-Wire Controller Data I/O
A6	P0.7	P0.7	SPI0_SCK	OWM_PE	SPI0 Clock; 1-Wire Controller Pull-up Enable Output
B4	P0.10	P0.10	I2C0_SCL	SPI0_SS2	I2C0 Clock; SPI0 Target Select 2
A5	P0.11	P0.11	I2C0_SDA	SPI0_SS1	I2C0 Serial Data; SPI0 Target Select 1
A4	P0.12	P0.12	UART1A_RX	TMR1B_IOAN	UART1 Receive Port Map A; Timer 1 Inverted Output Port Map B
C3	P0.20	P0.20	SPI1_SS0	TMR1B_IOA	SPI1 Target Select 0; Timer 1 I/O 32 Bits or Lower 16 Bits Port Map B
B3	P0.21	P0.21	SPI1_MOSI	TMR1B_IOB	SPI1 Controller Out Target In Serial Data 0; Timer 1 I/O Upper 16 Bits Port Map B
A3	P0.22	P0.22	SPI1_MISO	TMR1B_IOAN	SPI1 Controller In Target Out Serial Data 1; Timer 1 Inverted Output Port Map B

51 WLP

PIN	NAME	FUNCTION MODE			FUNCTION
		Primary Signal (Default)	Alternate Function 1	Alternate Function 2	
C2	P0.23	P0.23	SPI1_SCK	TMR1B_IOBN	SPI1 Clock; Timer 1 Inverted Output Upper 16 Bits Port Map B
B2	P0.26	P0.26	TMR2A_IOA	SPI1_SS1	Timer 2 I/O 32 Bits or Lower 16 Bits Port Map A; SPI1 Target Select 1
A2	P0.28	SWDIO	SWDIO	—	Serial Wire Debug Data I/O
B1	P0.29	SWCLK	SWCLK	—	Serial Wire Debug Clock
C1	P1.6	P1.6	TMR3A_IOA	BLE_ANT_CTR L2	Timer 3 I/O 32 Bits or Lower 16 Bits Port Map A; Bluetooth Antenna Control Line 2
F6	P2.0	P2.0	AIN0/AIN0N	—	Analog-to-Digital Converter Input 0/Comparator 0 Negative Input
D7	P2.1	P2.1	AIN1/AIN0P	—	Analog-to-Digital Converter Input 1/Comparator 0 Positive Input
C8	P2.6	P2.6	LPTMR0_CLK/ AIN6/AIN3N	LPUARTB_RX	Low-Power Timer 0 External Clock Input/ Analog-to-Digital Converter Input 6/Comparator 3 Negative Input; Low-Power UART 0 Receive Port Map B
D5	P2.7	P2.7	LPTMR1_CLK/ AIN7/AIN3P	LPUARTB_TX	Low-Power Timer 1 External Clock Input/ Analog-to-Digital Converter Input 7/Comparator 3 Positive Input; Low-Power UART Transmit Port Map B
ANTENNA OUTPUT					
H2	ANT	—	—	—	Antenna for Bluetooth Radio. Attach the single-ended, unbalanced Bluetooth radio antenna. If Bluetooth functionality is not used, and there is no antenna connected, do not connect this device pin.

Detailed Description

The MAX32655 microcontroller (MCU) is an advanced system-on-chip (SoC) featuring an Arm® Cortex®-M4F CPU for efficient computation of complex functions and algorithms that is qualified to operate at a temperature range of -40°C to +105°C. The SoC integrates power regulation and management with a single inductor multiple-output (SIMO) buck regulator system. The latest generation Bluetooth® 5.2 Low Energy (LE) radio is on board, supporting long-range (coded) and high-throughput modes and medical body area network (MBAN).

The device offers large onboard memory with 512KB flash and 128KB SRAM, with optional error correction coding (ECC) on one 32KB SRAM bank. This 32KB bank can be optionally retained in BACKUP mode. An 8KB user OTP area is available.

The MAX32655 supports multiple high-speed peripherals, such as I²C, 50MHz SPI, and UART, plus one I²S port for connecting to an audio codec. An eight-input, 10-bit ADC is available to monitor analog input from external analog sources. In addition, a low-power UART (LPUART) is available for operation in the lowest power sleep modes to facilitate wake-up activity without any data loss. A total of six timers with I/O capability are provided, including two low-power timers to enable pulse counting, capture/compare, and pulse-width modulation (PWM) generation, even in the lowest power sleep modes.

The MAX32655 is available in two different packages:

- 81 CTBGA (8mm x 8mm, 0.8mm pitch)
- 51 WLP (3.09mm x 3.09mm, 0.35mm pitch)

Arm Cortex-M4 (CM4) with FPU Processor and RISC-V (RV32) Processor

The Arm Cortex-M4 with FPU processor is ideal for low-power system control. The architecture combines high-efficiency signal processing functionality with low power, low cost, and ease of use.

The Arm Cortex-M4 with FPU DSP supports single instruction multiple data (SIMD) path DSP extensions, providing:

- Four parallel 8-bit add/sub
- Floating-point single precision
- Two parallel 16-bit add/sub
- Two parallel MACs
- 32- or 64-bit accumulate
- Signed and unsigned data with or without saturation

The addition of 32-bit RISC-V processor (RV32) provides the system with ultra-low-power consumption signal processing.

Memory

Internal Flash Memory

512KB of internal flash memory provides nonvolatile storage of program and data memory.

Internal SRAM

The internal 128KB SRAM provides low-power retention of application information in all power modes except POWER DOWN. The SRAM is divided into four banks. SRAM0 and SRAM1 are both 32KB, SRAM2 is 48KB, and SRAM3 is 16KB. SRAM2 and SRAM3 are accessible by the RV32 in LOW POWER mode. For enhanced system reliability, SRAM0 (32KB) can be configured with error correction coded (ECC) or single error correction-double error detection (SED-DED). This data retention feature is optional and configurable. This granularity allows the application to minimize its power consumption by only retaining the most essential data.

Bluetooth 5.2

Bluetooth 5.2 Low Energy Radio

Bluetooth 5.2 LE is the latest version of the Bluetooth wireless communication standard. Bluetooth LE communications

operate in the unlicensed 2.4GHz industrial-scientific-medical (ISM) band. A frequency-hopping transceiver is used to combat interference and fading. It uses 40 RF channels. These RF channels have $2402 + k \times 2\text{MHz}$ center frequencies, where $k = 0, \dots, 39$. The Bluetooth stack runs on RV32, so the CM4 can be freed to run the software. The features of the radio include the following:

- Higher transmit power up to +5.5dbm
- 1Mbps, 2Mbps, and long-range coded (125kbps and 500kbps)
- Increased broadcast capability
 - Advertising packet up to 255 bytes
- On-chip matching network to the antenna
- Antenna control outputs
- Provides hardware on-the-fly encryption and decryption for lower power consumption
- Low transmit current of 4.17mA at 0dbm at 3.3V
- Low receive current of 4.0mA at 3.3V
- Supports MBAN

Bluetooth 5.2 Software Stack

A Bluetooth 5.2 software stack is available for application developers to quickly add support to devices. The Arm Cordio®-B50 software stack is provided in library form and provides application developers access to Bluetooth technology without validation and development of a software stack. The Cordio-B50 software stack interfaces to the Bluetooth link layer running on dedicated hardware. The dedicated hardware for the stack enables the ultimate in power management for IoT applications. Cordio-B50 features the following:

- C library for linking directly into an application development tool
- Change PHY support
 - Host selects the PHY it needs to use at any given time enabling long range or higher bandwidth only when required
 - Bluetooth LE 1M
 - Bluetooth LE Coded S = 2
 - Bluetooth LE Coded S = 8
 - Bluetooth LE 2M
- Bluetooth 5.2 advertising extension support for enabling next-generation Bluetooth beacons
 - Larger packets and advertising channel offloading
 - Packets up to 255 octets long
 - Advertising packet chaining
 - Advertising sets
 - Periodic advertising
 - High-duty cycle non-connectable advertising
 - Sample applications using standard profiles built on the Cordio-B50 software framework

Comparators

The ADC inputs can be configured as pairs and deployed as independent comparators with the following features:

- Comparison events can trigger interrupts
- Events can wake the CM4 from SLEEP, LPM, UPM, STANDBY, or BACKUP operating modes
- Can be active in all power modes

The instances and characteristics of the peripheral are shown in [Table 1](#). Some instances may not be available in every package configuration; see the [Ordering Information](#) table for the specific instances available by part number.

Table 1. MAX32655 Comparator Instances

PACKAGES	
81 CTBGA	51 WLP
CMP0 (AIN0N/AIN0P) CMP1 (AIN1N/AIN1P) CMP2 (AIN2N/AIN2P) CMP3 (AIN3N/AIN3P)	CMP0 (AIN0N/AIN0P) CMP3 (AIN3N/AIN3P)

Clocking Scheme

Multiple clock sources can be selected as the system clock:

- Internal primary oscillator (IPO) at a nominal frequency of 100MHz
- Internal secondary oscillator (ISO) at a nominal frequency of 60MHz
- Configurable internal nano-ring oscillator (INRO) at 8kHz, 16kHz, or 30kHz
- External RTC oscillator at 32.768kHz (ERTCO)—external crystal required
- Internal baud rate oscillator at 7.3728MHz (IBRO)
- External square-wave clock up to 80MHz
- External RF oscillator at 32MHz (ERFO)—external crystal required
 - An internal kick-start circuit improves the ERFO startup time.

There are multiple external clock inputs:

- LPTMR0 and LPTMR1 can be clocked from unique external sources.
- SYS_CLK can be derived from an external source.

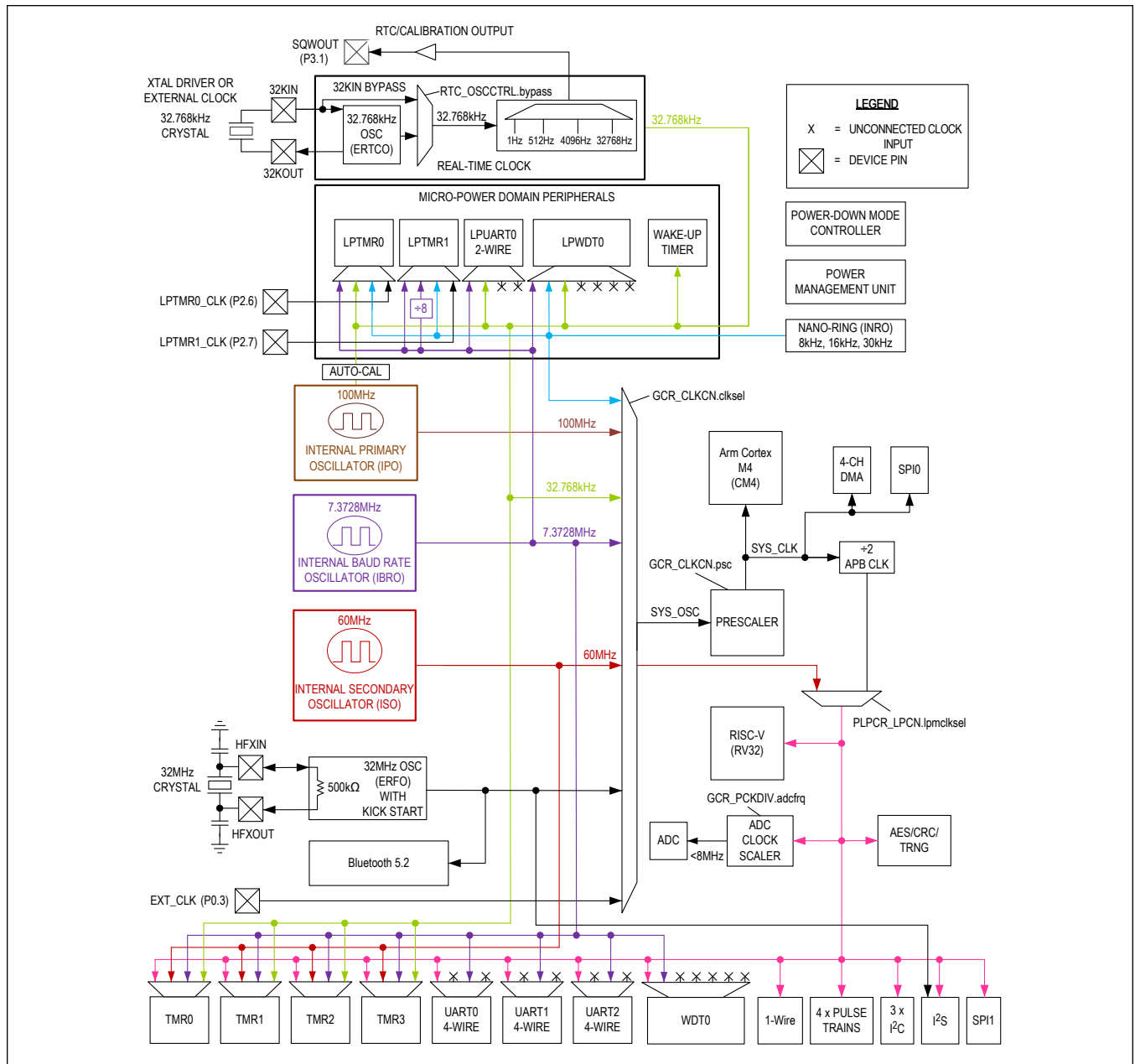

Figure 8. 81 CTBGA Clocking Scheme Diagram

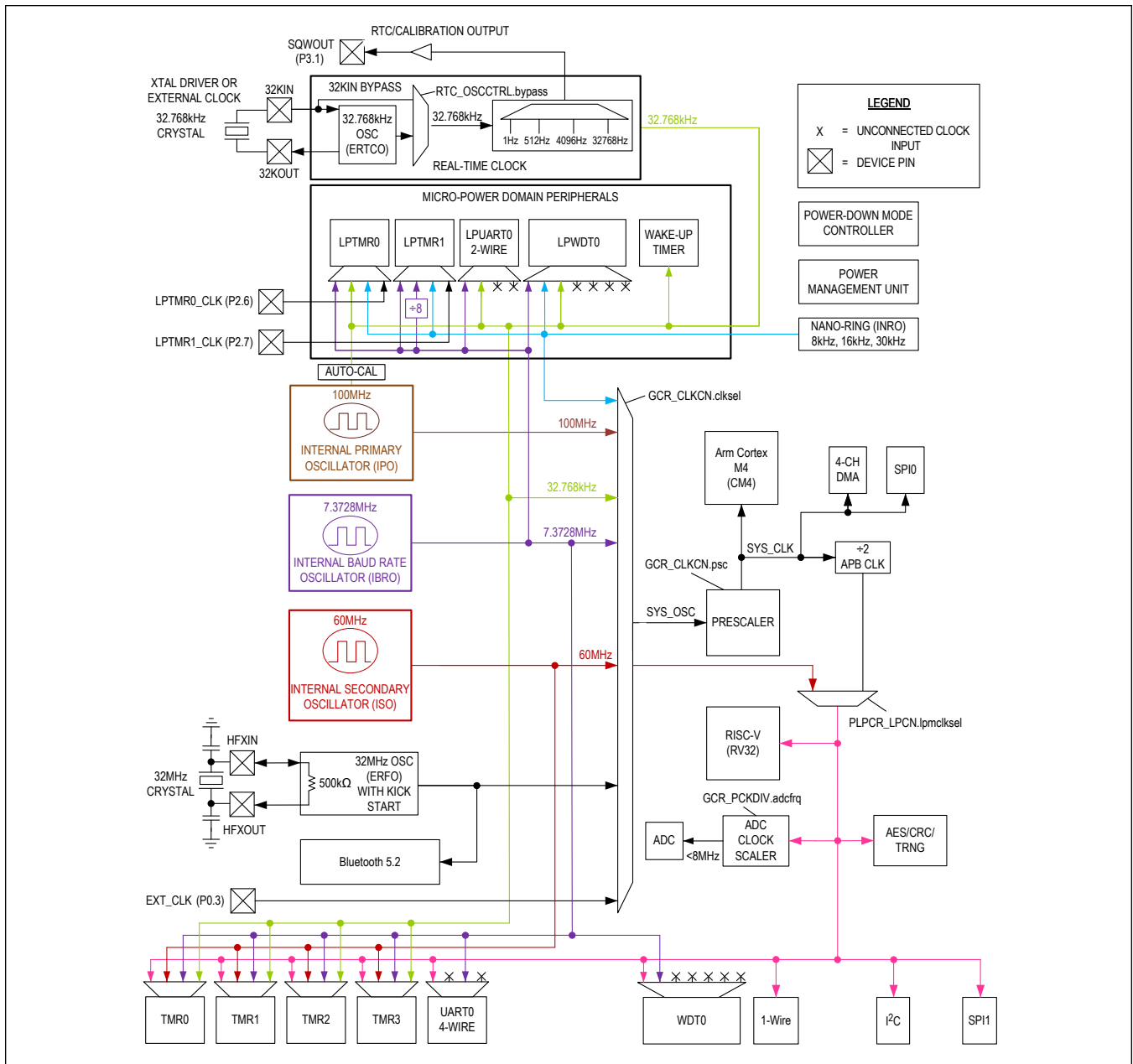

Figure 9.51 WLP Clocking Scheme Diagram

General-Purpose I/O (GPIO) and Special Function Pins

Most GPIO pins share both a firmware-controlled I/O function and one or more alternate functions associated with peripheral modules. Pins can be individually enabled for GPIO or peripheral special function use. Configuring a pin as a special function usually supersedes its use as a firmware-controlled I/O. Although this multiplexing between peripheral and GPIO functions is usually static, it can also be done dynamically. The electrical characteristics of a GPIO pin are identical whether the pin is configured as an I/O or special function, except where explicitly noted in the [Electrical Characteristics](#) tables.

Caution is needed since Port 3 (P3.0 and P3.1 device pins) is configured in a different manner from the above description.

In GPIO mode, pins are logically divided into ports of 32 pins. Each pin of a port has an interrupt function that can be independently enabled, and configured as a level- or edge-sensitive interrupt. All GPIOs of a given port share the same interrupt vector.

When configured as GPIO, all features can be independently enabled or disabled on a per-pin basis. The following features are provided:

- Configurable as input, output, bidirectional, or high impedance
- Optional internal pull-up resistor or internal pull-down resistor when configured as input
- Exit from low-power modes on rising or falling edge
- Selectable standard- or high-drive modes

Up to 52 GPIO pins are provided. The number of GPIOs varies by part package configuration; see the [Ordering Information](#) table for the number of GPIOs available by part number.

Analog-to-Digital Converter (ADC)

The 10-bit sigma-delta (Σ - Δ) ADC provides an integrated reference generator and a single-ended input multiplexer. The multiplexer selects an input channel from one of the eight external analog input signals (AIN0–AIN7) or the internal power supply inputs.

The reference for the ADC can be:

- Internal 1.22V bandgap
- V_{SSA} analog supply

An optional feature allows samples captured by the ADC to be automatically compared against user-programmable high and low limits. Up to four channel limit pairs can be configured in this way. The comparison allows the ADC to trigger an interrupt (and potentially wake the CPU from a power mode) when a captured sample goes outside the preprogrammed limit range. The eight ADC inputs can be configured as pairs and deployed as independent comparators.

The ADC measures the following voltages:

- AIN[7:0] up to 3.3V
- V_{REGI}
- V_{COREA}
- V_{COREB}
- V_{DDIOH}
- V_{DDIO}
- V_{TXOUT}
- V_{RXOUT}
- V_{DDA}

See [Table 2](#) for details of instances of the ADC.

Table 2. MAX32655 ADC External Inputs

PACKAGES		OPERATING MODES
81 CTBGA	51 WLP	
AIN0 AIN1 AIN2 AIN3 AIN4 AIN5 AIN6 AIN7	AIN0 AIN1 AIN6 AIN7	ACTIVE SLEEP LPM

Single-Inductor Multiple-Output (SIMO) Switch-Mode Power Supply (SMPS)

The SIMO SMPS built into the device provides a monolithic power supply architecture for operation from a single lithium cell. The SIMO provides four buck regulator outputs that are voltage programmable. This architecture optimizes power consumption efficiency of the device and minimizes the bill of materials for the circuit design since only a single inductor/

capacitor pair is required.

Power Management

Power Management Unit (PMU)

The PMU provides high-performance operation while minimizing power consumption. It exercises intelligent, precise control of power distribution to the CPUs and peripheral circuitry.

The PMU provides the following features:

- User-configurable system clock
- Automatic enabling and disabling of crystal oscillators based on power mode
- Multiple power domains
- Fast wake-up of powered-down peripherals when activity detected

ACTIVE Mode

In this mode, the CM4 and the RV32 can execute application code and all digital and analog peripherals are available on demand. Dynamic clocking disables peripherals not in use, providing the optimal mix of high performance and low power consumption. The CM4 has access to all system SRAM. The RV32 has access to SRAM2 and SRAM3. Both the CM4 and the RV32 can execute from internal flash simultaneously. SRAM3 can be configured as an instruction cache for the RV32.

SLEEP Mode

This mode allows for lower power consumption operations than ACTIVE mode. The GPIO or any active peripheral can be configured to interrupt and cause a transition to ACTIVE mode. This mode consumes less power, but wakes faster because the clocks can optionally be enabled.

The device status is as follows:

- CM4 is in the Arm Cortex-M4 processor SLEEP mode.
- RV32 is asleep.
- Peripherals are on.
- Standard DMA is available for optional use.

LOW POWER Mode (LPM)

This mode is suitable for running the RV32 processor to collect and move data from enabled peripherals.

The device status is as follows:

- The CM4, SRAM0, and SRAM1 are in state retention.
- The RV32 can access the SPI, all UARTS, all timers, I²C, 1-Wire, pulse train engines, I²S, CRC, AES, TRNG, PCIF, and comparators, as well as SRAM2 and SRAM3. SRAM3 can be configured to operate as RV32 instruction cache.
- The transition from LOW POWER mode to ACTIVE mode is faster than the transition from BACKUP mode because system initialization is not required.
- The DMA can access flash.
- IPO can be optionally powered down.
- The following oscillators are enabled:
 - IBRO
 - ERTCO
 - INRO
 - ISO
 - ERFO

MICRO POWER Mode (UPM)

This mode is used for extremely low power consumption while using a minimal set of peripherals to provide wake-up capability.

The device status is as follows:

- Both CM4 and RV32 are state retained. (System state and all SRAM is retained.)
- The GPIO pins retain their state.
- All non-UPM peripherals are state retained.
- IBRO can be optionally powered down.
- The following oscillators are powered down:
 - IPO
 - ISO
 - ERFO
- The following oscillators are enabled:
 - IBRO
 - ERTCO
 - INRO
- The following UPM peripherals are available for use to wake up the device:
 - LPUART0
 - WWDT1
 - All four low-power analog comparators

STANDBY Mode

This mode is used to maintain the system operation while keeping time with the RTC.

The device status is as follows:

- Both CM4 and RV32 are state retained. (System state and all SRAM is retained.)
- The GPIO pins retain their state.
- RTC is on.
- All peripherals are state retained.
- The following oscillators are powered down:
 - IPO
 - ISO
 - IBRO
 - ERFO
- The following oscillators are enabled:
 - ERTCO
 - INRO

BACKUP Mode

This mode is used to maintain the system RAM while keeping time with the RTC. The device status is as follows:

- CM4 and RV32 are powered off.
- SRAM0, SRAM1, SRAM2, and SRAM3 can be configured to be state retained as per [Table 3](#).
- All peripherals are powered off.
- The GPIO pins retain their state.
- RTC is on.
- The following oscillators are powered down:
 - IPO
 - ISO
 - IBRO
 - ERFO
- The following oscillators are enabled:
 - ERTCO
 - INRO

Table 3. BACKUP Mode SRAM Retention

RAM BLOCK	RAM SIZE
SRAM0	32KB + ECC
SRAM1	32KB
SRAM2	48KB
SRAM3	16KB

POWER DOWN Mode (PDM)

This mode is used during product level distribution and storage.

The device status is as follows:

- The CM4 and RV32 are powered off.
- All peripherals and SRAM are powered down.
- All oscillators are powered down.
- 8 bytes of data are retained.
- Values in the flash are preserved.
- Voltage monitors are operational.

Wake-up Sources

The wake-up sources from the power modes are summarized in [Table 4](#).

Table 4. MAX32655 Wake-up Sources

OPERATING MODE	WAKE-UP SOURCE
SLEEP	Any enabled peripheral with interrupt capability; RSTN
LOW POWER (LPM)	SPI0, I ² S, I ² C, UARTs, timers, watchdog timers, wake-up timer, all comparators, RTC, GPIOs, RSTN, and RV32
MICRO POWER (UPM)	All comparators, LPUART (where available), LPTMR0, LPTMR1, LPWDT0, RTC, wake-up timer, GPIOs, and RSTN
STANDBY	RTC, wake-up timer, GPIOs, CMP0 (where available), and RSTN
BACKUP	RTC, wake-up timer, GPIOs, CMP0 (where available), and RSTN
POWER DOWN (PDM)	P3.0 and RSTN

Real-Time Clock (RTC)

An RTC keeps the time of day in absolute seconds. The 32-bit seconds register can count up to approximately 136 years and be translated to calendar format by application software.

The RTC provides a time-of-day alarm that is programmable to any future value between 1 second and 12 days. When configured for long intervals, the time-of-day alarm is usable as a power-saving timer, allowing the device to remain in an extremely low-power mode, but still awaken periodically to perform assigned tasks. A second independent 32-bit 1/4096 subsecond alarm is programmable with a tick resolution of 244 μ s. Both can be configured as recurring alarms. When enabled, either alarm can cause an interrupt or wake the device from most low-power modes.

The time base is generated by a 32.768kHz crystal or an external clock source that must meet the electrical/timing requirements in the [Electrical Characteristics](#) table. The RTC oscillator does not require external load capacitors.

The RTC calibration feature provides the ability for user software to compensate for minor variations in the RTC oscillator, crystal, temperature, and board layout. Enabling the SQWOUT alternate function outputs a timing signal derived from the RTC. External hardware can measure the frequency and adjust the RTC frequency in increments of ± 127 ppm with 1ppm resolution. Under most circumstances, the oscillator does not require any calibration.

Programmable Timers

32-Bit Timer/Counter/PWM (TMR, LPTMR)

General-purpose, 32-bit timers provide timing, capture/compare, or generation of pulse-width modulated (PWM) signals with minimal software interaction.

The timer provides the following features:

- 32-bit up/down autoreload
- Programmable prescaler
- PWM output generation
- Capture, compare, and capture/compare capability
- External pin multiplexed with GPIO for timer input, clock gating, or capture
- Timer output pin
- TMR0–TMR3 can be configured as two 16-bit general-purpose timers
- Timer interrupt

The instances and characteristics of the peripheral are shown in [Table 5](#). Some instances and I/O functionality may not be available in every package configuration; see the [Ordering Information](#) table for the specific instances available by part number.

Table 5. MAX32655 Timer Instances

INSTANCE	REGISTER ACCESS NAME	SINGLE 32 BIT	DUAL 16 BIT	SINGLE 16 BIT	POWER MODE	CLOCK SOURCE						
						PCLK	ISO	IBRO	INRO	ERTCO	LPTMR0_CLK	LPTMR1_CLK
TMR0	TMR0	Yes	Yes	No	ACTIVE, SLEEP, LPM	Yes	Yes	Yes	No	Yes	No	No
TMR1	TMR1	Yes	Yes	No	ACTIVE, SLEEP, LPM	Yes	Yes	Yes	No	Yes	No	No
TMR2	TMR2	Yes	Yes	No	ACTIVE, SLEEP, LPM	Yes	Yes	Yes	No	Yes	No	No
TMR3	TMR3	Yes	Yes	No	ACTIVE, SLEEP, LPM	Yes	Yes	Yes	No	Yes	No	No
LPTMR0	TMR4	No	No	Yes	ACTIVE, SLEEP, LPM, UPM	No	No	Yes	Yes	Yes	Yes	No
LPTMR1*	TMR5	No	No	Yes	ACTIVE, SLEEP, LPM, UPM	No	No	Yes	Yes	Yes	No	Yes

* Available as an internal timer only on the 51-bump WLP. There is no external connection to this timer on the 51-bump WLP.

Watchdog Timer (WDT)

Microcontrollers are often used in harsh environments where electrical noise and electromagnetic interference (EMI) are abundant. Without proper safeguards, these hazards can disturb device operation and corrupt program execution. One of the most effective countermeasures is the WDT, which detects runaway code or system unresponsiveness.

The WDT is a 32-bit, free-running counter with a configurable prescaler. When enabled, the WDT must be periodically reset by the application software. Failure to reset the WDT within the user-configurable timeout period indicates that the

application software is not operating correctly and results in a WDT timeout. A WDT timeout can trigger an interrupt, system reset, or both. Either response forces the instruction pointer to a known good location before resuming instruction execution.

The windowed timeout period feature provides more detailed monitoring of system operation, requiring the WDT to be reset within a specific window of time.

The instances and characteristics of the peripheral are shown in [Table 6](#). Some instances may not be available in every package configuration; see the [Ordering Information](#) table for the specific instances available by part number.

Table 6. MAX32655 Watchdog Timer Instances

INSTANCE NAME	REGISTER ACCESS NAME	POWER MODE	CLOCK SOURCE			
			PCLK	IBRO	INRO	ERTCO
WDT0	WDT0	ACTIVE, SLEEP, LPM	Yes	Yes	No	No
LPWDT0	WDT1	ACTIVE, SLEEP, LPM, UPM	No	Yes	Yes	Yes

Pulse Train Engine (PT)

Multiple, independently-configurable pulse train generators can provide pulse-width modulation, a square wave, or a repeating pattern from 2 to 32 bits. Any single pulse train generator or desired group of pulse train generators can be synchronized at the bit level, allowing for multi-bit patterns.

The pulse train generators provide the following features:

- Independently enabled
- Safe enable and disable for pulse trains without bit banding
- Multiple pin configurations allow for a flexible layout
- Pulse trains can be started/synchronized independently or as a group
- Frequency of each enabled pulse train generator is also set separately, based on a divide down (divide by 2, divide by 4, divide by 8, and so on) of the input pulse train module clock
- Input pulse train module clock can be optionally configured to be independent of the system AHB clock
- Multiple repetition options
 - Single shot (nonrepeating pattern of 2 to 32 bits)
 - Pattern repeats a user-configurable number of times or indefinitely
 - Termination of one pulse train loop count can restart one or more other pulse trains

The instances and characteristics of the peripheral are shown in [Table 7](#). Some instances may not be available in every package configuration; see the [Ordering Information](#) table for the specific instances available by part number.

Table 7. MAX32655 Pulse Train Instances

PACKAGES		INSTANCE
81 CTBGA	51 WLP	
Yes	No	PT0
Yes	No	PT1
Yes	No	PT2
Yes	No	PT3

Serial Peripherals

I²C Interface (I2C)

The I²C interface is a bidirectional, two-wire serial bus that provides a medium-speed communications network. It can

operate as a one-to-one, one-to-many, or many-to-many communication medium. This interface supports Standard-mode, Fast-mode, and Fast-mode Plus I²C speeds. It provides the following features:

- Controller or target mode operation
 - Supports up to four different target addresses in target mode
- Supports standard 7-bit addressing or 10-bit addressing
- RESTART condition
- Interactive receive mode (IRXM)
- Transmitter FIFO preloading
- Support for clock stretching to allow slower target devices to operate on higher speed busses
- Multiple transfer rates
 - Standard-mode: 100kbps
 - Fast-mode: 400kbps
 - Fast-mode Plus: 1000kbps
- Internal filter to reject noise spikes
- Receiver FIFO depth of 8 bytes
- Transmitter FIFO depth of 8 bytes

The instances and characteristics of the peripheral are shown in [Table 8](#). Some instances may not be available in every package configuration; see the [Ordering Information](#) table for the specific instances available by part number.

Table 8. MAX32655 I²C Instances

PACKAGES	
81 CTBGA	51 WLP
I2C0 I2C1 I2C2	I2C0

I²S Interface (I2S)

The I²S interface is a bidirectional, four-wire serial bus that provides serial communications for codecs and audio amplifiers compliant with the I²S Bus Specification, June 5, 1996. It provides the following features:

- Controller and target mode operation
- Selectable bits per word from 1 to 32
- Receive and transmit DMA support
- Word-select polarity control
- First bit position selection
- Interrupts generated for FIFO status
- Receiver FIFO depth of 32 bytes
- Transmitter FIFO depth of 32 bytes

This peripheral may not be available in every package configuration; see the [Ordering Information](#) table for the specific instances available by part number.

Serial Peripheral Interface (SPI)

The SPI is a highly configurable, flexible, and efficient synchronous interface where multiple SPI devices can coexist on a single bus. The bus uses a single clock signal, multiple data signals, and one or more target select lines to address only the intended target device. The SPI operates independently and requires minimal processor overhead.

The provided SPI peripherals can operate in either target or controller mode and provide the following features:

- SPI modes 0, 1, 2, or 3 for single-bit communication
- 3- or 4-wire mode for single-bit target device communication
- Full-duplex operation in single-bit, 4-wire mode
- Dual and quad data modes supported
- Multiple target selects on some instances
- Multicontroller mode fault detection

- Programmable interface timing
- Programmable SCK frequency and duty cycle
- 32-byte transmit and receive FIFOs
- Target select assertion and deassertion timing concerning leading/trailing SCK edge

The instances and characteristics of the peripheral are shown in [Table 9](#). Some instances may not be available in every package configuration; see the [Ordering Information](#) table for the specific instances available by part number.

Table 9. MAX32655 SPI Instances

PACKAGE		INSTANCE	FORMATS	TARGET SELECT LINES	MAXIMUM FREQUENCY CONTROLLER MODE (MHz)	MAXIMUM FREQUENCY TARGET MODE (MHz)
81 CTBGA	51 WLP					
Yes	—	SPI0	3-wire 4-wire dual quad	3	50 (Mode 0 and Mode 2) 25 (Mode 1 and Mode 3)	50 (Mode 0 and Mode 2) 25 (Mode 1 and Mode 3)
Yes	—	SPI1		1	25 (All SPI modes)	25 (All SPI modes)
—	Yes	SPI0	3-wire 4-wire dual	3	50 (Mode 0 and Mode 2) 25 (Mode 1 and Mode 3)	50 (Mode 0 and Mode 2) 25 (Mode 1 and Mode 3)
—	Yes	SPI1		2	25 (All SPI modes)	25 (All SPI modes)

UART (UART, LPUART)

The universal asynchronous receiver-transmitter (UART, LPUART) interface supports full-duplex asynchronous communication with optional hardware flow control (HFC) modes to prevent data overruns. If HFC mode is enabled on a given port, the system uses two extra pins to implement the industry-standard request to send (RTS) and clear to send (CTS) flow control signaling. Each instance is individually programmable.

- 2-wire interface or 4-wire interface with flow control
- 8-byte send/receive FIFO
- Full-duplex operation for asynchronous data transfers
- Interrupts available for frame error, parity error, CTS, Rx FIFO overrun, and FIFO full/partially full conditions
- Automatic parity and frame error detection
- Independent baud-rate generator
- Programmable 9th-bit parity support
- Multidrop support
- Start/stop bit support
- Hardware flow control using RTS/CTS
- Two DMA channels can be connected (read and write FIFOs)
- Programmable word size (5 bits to 8 bits)

The instances and characteristics of the peripheral are shown in [Table 10](#). Some instances may not be available in every package configuration; see the [Ordering Information](#) table for the specific instances available by part number.

Table 10. MAX32655 UART Instances

PACKAGE		INSTANCE NAME	REGISTER ACCESS NAME	HARDWARE FLOW CONTROL	POWER MODE	CLOCK SOURCE		
81 CTBGA	51 WLP					PCLK	IBRO	ERTCO
Yes	Yes	UART0	UART0	Yes	ACTIVE, SLEEP, LPM	Yes	Yes	No
Yes	No	UART1	UART1	Yes	ACTIVE, SLEEP, LPM	Yes	Yes	No

Table 10. MAX32655 UART Instances (continued)

PACKAGE		INSTANCE NAME	REGISTER ACCESS NAME	HARDWARE FLOW CONTROL	POWER MODE	CLOCK SOURCE		
81 CTBGA	51 WLP					PCLK	IBRO	ERTCO
Yes	No	UART2	UART2	81 CTBGA only	ACTIVE, SLEEP, LPM	Yes	Yes	No
Yes	Yes	LPUART0	UART3	No	ACTIVE, SLEEP, LPM	No	Yes	Yes
					UPM	No	No	Yes

1-Wire Controller (OWM)

Analog Devices' 1-Wire bus consists of one signal that carries data and also supplies power to the target devices and a ground return. The bus controller communicates serially with one or more target devices through the bidirectional, multidrop 1-Wire bus. The single-contact serial interface is ideal for communication networks requiring minimal interconnection.

The provided 1-Wire controller supports the following features:

- Single contact for control and operation
- Unique factory identifier for any 1-Wire device
- Multiple device capability on a single line

The OWM supports both standard (15.6kbps) and overdrive (110kbps) speeds.

Standard DMA Controller

The standard DMA controller allows automatic one-way data transfer between two entities. These entities can be either memories or peripherals. The transfers are done without using CPU resources. The following transfer modes are supported:

- 4-channel
- Peripheral to data memory
- Data memory to peripheral
- Data memory to data memory
- Event support

All DMA transactions consist of an AHB burst read into the DMA FIFO, followed immediately by an AHB burst write from the FIFO.

The MAX32655 provides one instance of the standard DMA controller.

Security**AES**

The dedicated hardware-based AES engine supports the following algorithms:

- AES-128
- AES-192
- AES-256

The AES keys are automatically generated by the engine and stored in dedicated flash to protect against tampering. Key generation and storage is transparent to the user.

True Random Number Generator (TRNG)

The device provides a non-deterministic entropy source that can be used to generate cryptographic seeds or strong encryption keys as part of an overall framework for a secure customer application.

Software can use random numbers to trigger asynchronous events that add complexity to program execution to thwart

replay attacks or key search methodologies.

CRC Module

A cyclic redundancy check (CRC) hardware module provides fast calculations and data integrity checks by application software. It supports a user-defined programmable polynomial up to 32-bits. Direct memory access copies data into the CRC module so that CRC calculations on large blocks of memory are performed with minimal CPU intervention. Examples of common polynomials are depicted in [Table 11](#).

Table 11. Common CRC Polynomials

ALGORITHM	POLYNOMIAL EXPRESSION
CRC-32-ETHERNET	$x^{32} + x^{26} + x^{23} + x^{22} + x^{16} + x^{12} + x^{11} + x^{10} + x^8 + x^7 + x^5 + x^4 + x^2 + x^1 + x^0$
CRC-CCITT	$x^{16} + x^{12} + x^5 + x^0$
CRC-16	$x^{16} + x^{15} + x^2 + x^0$
USB DATA	$x^{16} + x^{15} + x^2 + x^0$
PARITY	$x^1 + x^0$

Secure Communications Protocol Bootloader (SCPBL)

The MAX32655 does not support an SCPBL. The user must use SWD to load software for execution.

Secure Boot

On devices that support Secure Boot, the device performs a secure boot to confirm that the root of trust has not been compromised. Following every reset and exit from certain low-power modes, the secure boot verifies the digital signature of the program memory to confirm it has not been modified or corrupted, ensuring the trustworthiness of the application software. Failure to verify the digital signature transitions the device to safe mode, which prevents execution of the customer code. During the development phase, the bootloader can be reactivated and a new, trusted program memory loaded. Refer to the [MAX32655 User Guide](#) for more details.

Debug and Development Interface (SWD, JTAG)

The serial wire debug (SWD) interface is used for debugging the CM4 and loading software for both the CM4 and the RV32. The JTAG interface is provided for debugging the RV32. All devices in mass production have the debugging/development interface enabled.

Applications Information

Bypass Capacitors

The proper use of bypass capacitors reduces noise generated by the IC into the ground plane. The [Pin Descriptions](#) table indicates which pins should be connected to bypass capacitors, and the appropriate ground plane.

It is recommended that one instance of a bypass capacitor should be connected to each pin/ball of the IC package. For example, if the [Pin Descriptions](#) table shows four device pins associated with voltage supply A, a separate capacitor should be connected to each pin for a total of four capacitors.

Capacitors should be placed as close as possible to their corresponding device pins. Pins which recommend more than one value of capacitor per pin should place them in parallel with the lowest value capacitor first, closest to the pin.

RTC Crystal Guidelines

The internal low-power RTC oscillator minimizes power consumption and maximizes battery life. The RTC crystal must be designed to reach its nominal frequency with 6pF (called C_L or C_{L_XTAL} in the [Electrical Characteristics](#) table) of load capacitance. Crystals designed for values of C_{L_XTAL} greater than 6pF are not supported. Note that crystal load capacitors are electrically in series across the crystal, so the correct value of total pad and trace capacitance for a "6pF crystal" is 12pF per terminal. The RTC in this part includes integrated load capacitors. External load capacitors are not required for RTC operation.

A digital trim feature can compensate for RTC inaccuracies of up to ± 127 ppm when compared against an external reference clock. Refer to the [MAX32655 User Guide](#) for details.

Although they are not required, customers can also tune the clock using external load capacitors. Final C values must be determined after the PCB layout is complete. However, the low-power design of the RTC oscillator imposes a maximum of 12pF ($C_{PAD} + C_{STRAY} + C_{L_XTAL}$) total per pin.

Device PCB Power Connectivity

The [Table 12](#) depicts the power supply device pin connections for any design to be made at the PCB level. No external components can be connected to the V_{REGO_X} regulator outputs. Doing so will cause excessive loading during low-power operating modes, leading to possible device resets. An external 1.8V supply must bias external components operating at the V_{DDIO} voltage.

Table 12. Device PCB Power Connectivity

DEVICE PIN	CONNECTION
V_{REGI}	Battery
V_{DDA}	V_{REGO_A}
V_{DDIO}	V_{REGO_A}
V_{DDIOH}	V_{REGI}
BLE_LDO_IN	V_{REGO_D}
V_{COREA}	V_{REGO_C}
V_{COREB}	V_{REGO_B}
V_{BST}	LXB through a 3.3nF capacitor
LXA	LXB through a 2.2 μ H inductor

V_{REGI} Design Considerations

The internal SIMO regulator requires one minimum 22 μ F capacitor between V_{REGI} and V_{SSPWR} . Larger capacitance values improve decoupling for the SIMO regulator and reduce current peaks drawn from the battery.

Place the capacitor as close as possible to the pin shown in [Table 13](#). The ESR/ESL of the input capacitor should be very low (i.e., $\leq 5m\Omega + \leq 500pH$) for frequencies up to 2MHz. Ceramic capacitors with X5R or X7R dielectric are highly recommended due to their small size, low ESR, and small temperature coefficients.

Table 13. MAX32655 V_{REGI} Capacitor Placement Priority

PACKAGE	PLACEMENT
81 CTBGA	C9
51 WLP	H4

Proper operation requires low inductance routing and minimization of the loop area between V_{REGI}, the capacitor, and the V_{SSPWR} ground plane.

Transmitted Spurious Emissions

Various local regulatory agencies can impose limits on transmitted spurious emissions. At maximum output power of +5.5dbm, compliance with local regulations can require either an antenna with at least 6dB rejection at the 7.2GHz third harmonic or the use of a lowpass filter network between the device RF port and antenna. The MAX32655 is designed with an on-chip matching network providing a 50Ω impedance at the ANT device pin. Filter design must match this impedance for best efficiency.

Typical Fixed Current Consumption Temperature Variance

ACTIVE Mode

Table 14. Fixed V_{REGI} Current Consumption ACTIVE Mode

PARAMETER	SYMBOL	CONDITIONS	TYPICAL					UNITS
			-40°C	25°C	55°C	85°C	105°C	
V _{REGI} Current, ACTIVE Mode	I _{REGI_FACT}	Fixed, IPO enabled, ISO disabled, total current into V _{REGI} pin, V _{REGI} = 3.0V, V _{COREA} = 1.0V, V _{COREB} = 0.81V; CM4 in ACTIVE mode 0MHz, RV32 in ACTIVE mode 0MHz; ECC disabled; inputs tied to V _{SS} or V _{DDIO} , or V _{DDIOH} ; outputs source/sink 0mA	506	570	659	840	1103	μA

SLEEP Mode

Table 15. Fixed V_{REGI} Current Consumption SLEEP Mode

PARAMETER	SYMBOL	CONDITIONS	TYPICAL					UNITS
			-40°C	25°C	55°C	85°C	105°C	
V _{REGI} Current, SLEEP Mode	I _{REGI_FSLP}	Fixed, IPO enabled, ISO disabled, total current into V _{REGI} pin, V _{REGI} = 3.0V; V _{COREA} = 1.0V, V _{COREB} = 0.81V, CM4 and RV32 in SLEEP mode 0MHz operation; ECC disabled; inputs tied to V _{SS} , V _{DDIO} or V _{DDIOH} ; outputs source/sink 0mA	506	570	659	840	1103	μA

STANDBY Mode

Table 16. Fixed V_{REGI} Current Consumption STANDBY Mode

PARAMETER	SYMBOL	CONDITIONS	TYPICAL					UNITS
			-40°C	25°C	55°C	85°C	105°C	
V _{REGI} Current, STANDBY Mode	I _{REGI_STBY}	Fixed, total current into V _{REGI} pin, V _{REGI} = 3.0V, V _{COREA} = 1.0V, V _{COREB} = 0.81V; inputs tied to V _{SS} or V _{DDIO} , or V _{DDIOH} ; outputs source/sink 0mA	1.2	2.1	4.6	12	25	μA

BACKUP Mode

Table 17. Fixed V_{REGI} Current Consumption BACKUP Mode

PARAMETER	SYMBOL	CONDITIONS	TYPICAL	UNITS

Table 17. Fixed V_{REGI} Current Consumption BACKUP Mode (continued)

			-40°C	25°C	55°C	85°C	105°C	
V _{REGI} Current, BACKUP Mode	I _{REGI_BK}	Fixed, total current into V _{REGI} pin, V _{REGI} = 3.0V, V _{COREA} = 1.0V, V _{COREB} = 0.81V; RTC disabled; inputs tied to V _{SS} or V _{DDIO} , or V _{DDIOH} ; outputs source/sink 0mA. All SRAM retained.	0.96	1.6	3.4	9.1	19.3	μA
		Fixed, total current into V _{REGI} pin, V _{REGI} = 3.0V, V _{COREA} = 1.0V, V _{COREB} = 0.81V; RTC disabled; inputs tied to V _{SS} or V _{DDIO} , or V _{DDIOH} ; outputs source/sink 0mA; No SRAM retained.	0.88	0.98	1.6	5	10.7	

Ordering Information

PART	UART	SPI	I ² C	PULSE TRAINS	EXT. ADC INPUTS/ COMPARATORS	LPUART	I ² S	GPIO	OPTIONALLY ENABLED SECURE BOOT	PIN-PACKAGE
MAX32655GXG+	4	2 x quad	3	4	8/4	1	1	52	Yes	81 CTBGA 8mm x 8mm, 0.8mm pitch
MAX32655GXG+T	4	2 x quad	3	4	8/4	1	1	52	Yes	81 CTBGA 8mm x 8mm, 0.8mm pitch
MAX32655GWJ+	1	2 x dual	1	0	4/2	1	0	23	Yes	51 WLP 3.09mm x 3.09mm, 0.35mm pitch
MAX32655GWJ+T	1	2 x dual	1	0	4/2	1	0	23	Yes	51 WLP 3.09mm x 3.09mm, 0.35mm pitch

All packages contain one RTC, CRC, OWM, TRNG, I²S, two WDT, and Bluetooth 5.2;

UART = Universal Asynchronous Receiver-Transmitter; SPI = Serial Peripheral Interface;

TMR = Timer; I²C = Inter-IC; ADC = Analog-to-Digital Converter; LPUART = Low-Power UART;

I²S = Inter-IC Sound; GPIO = General-Purpose Input/Output; RTC = Real-Time Clock;

CRC = Cyclic Redundancy Check; OWM = 1-Wire Controller; TRNG = True Random Number Generator

+ Denotes a lead(Pb)-free/RoHS-compliant package.

T = Tape and reel. Full reel.

Revision History

REVISION NUMBER	REVISION DATE	DESCRIPTION	PAGES CHANGED
0	8/20	Release for intro	—
1	9/21	Added 63 WLP Pin Configuration, Pin Descriptions, and Package Information. Updated the Electrical Characteristics and Ordering Information.	1, 7, 11, 32–36, 41, 52
2	11/21	Removed 63 WLP package and replaced with 60 WLP in Pin Configuration, Pin Descriptions, Package Information, General Description, and Detailed Description. Updated Ordering information to reflect package change to MAX32655GWY+ and MAX32655GWY+T.	1, 7, 32–36, 38, 41, 42, 46–49, 52
3	11/23	Added guidelines for RTC crystal, clarified RSTN causes a system reset, removed the requirement for 32KIN/32KOUT capacitors. Removed 60 WLP package information. Replaced all references to Master/Slave with Controller/Target. Updated the Simplified Block Diagram. Updated Electrical Characteristics for revision B silicon. Updated Pin Description for 81 CTBGA package. Updated the Clocking Scheme Diagram for 81 CTBGA package. Removed description of the Dynamic Voltage Scaling. Removed support for High-Speed I ² C. Updated Detailed Description. Updated Ordering Information.	1, 2, 7–13, 16–18, 20–24, 29–51
4	1/24	Added 51 WLP package information.	1, 7–9, 35–40, 41, 42, 44, 45, 49–57

Looking for pricing, stock, or lifecycle information?

Click below to explore more details on WIN SOURCE:

- ⊖ [View MAX32655GXG+ on WIN SOURCE](#)
- ⊖ [Maxim Integrated Information](#)

Optimize Your Supply Chain with WIN SOURCE Solutions

- ✓ Global Sourcing Solution
- ✓ Obsolete Management
- ✓ Cost Control Management
- ✓ Shortage Management
- ✓ Alternative Solution
- ✓ Excess Inventory Management