

Commercial Space Product GaAs, pHEMT, MMIC, Low Noise Amplifier, 23 GHz to 31 GHz

FEATURES

- ▶ Low noise figure: 1.8 dB typical at 27 GHz to 31 GHz
- ▶ Single positive supply (self biased)
- ▶ High gain: 26.5 dB typical at 27 GHz to 31 GHz
- ▶ High OIP3: 20 dBm typical at 27 GHz to 31 GHz
- ▶ Die size: 0.945 mm × 1.015 mm × 0.100 mm

COMMERCIAL SPACE FEATURES

- ▶ Wafer diffusion lot traceability
- ▶ Radiation benchmark
- ▶ Total ionizing dose (TID): 30 krad
- ▶ Single event latchup (SEL): ≥ 62.4 MeV-cm²/mg

APPLICATIONS

- ▶ Geosynchronous high throughput satellite (GEO HTS)
- ▶ Low Earth orbit (LEO) space payloads
- ▶ Satellite communication

GENERAL DESCRIPTION

The ADL8142-2C-CSL is a gallium arsenide (GaAs), monolithic microwave integrated circuit (MMIC), pseudomorphic high electron mobility transistor (pHEMT), low noise wideband amplifier that operates from 23 GHz to 31 GHz. The ADL8142-2C-CSL provides a typical gain of 26.5 dB, a 1.8 dB typical noise figure, and a typical output third-order intercept (OIP3) of 20 dBm at 27 GHz to 31 GHz, requiring only 25 mA from a 2 V supply voltage. Note that the OIP3 can be improved with larger drain currents. The ADL8142-2C-CSL also features inputs and outputs that are AC-coupled and internally matched to 50 Ω, making it ideal for high capacity microwave radio applications.

FUNCTIONAL BLOCK DIAGRAM

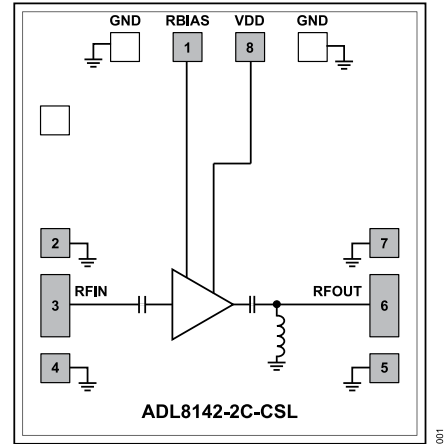

Figure 1.

TABLE OF CONTENTS

Features.....	1	Absolute Maximum Ratings.....	5
Commercial Space Features.....	1	Thermal Resistance.....	5
Applications.....	1	Outgas Testing.....	5
Functional Block Diagram.....	1	Electrostatic Discharge (ESD) Ratings.....	5
Specifications.....	3	ESD Caution.....	5
Frequency Range: 23 GHz to 27 GHz.....	3	Pin Configuration and Function Descriptions.....	6
Frequency Range: 27 GHz to 31 GHz.....	3	Typical Performance Characteristics.....	7
DC Specifications.....	3	Outline Dimensions.....	8
Radiation Test and Limit Specifications.....	4	Ordering Guide.....	8

REVISION HISTORY**11/2022—Revision 0: Initial Version**

SPECIFICATIONS

FREQUENCY RANGE: 23 GHZ TO 27 GHZ

$T_C = 25^\circ\text{C}$, supply voltage (V_{DD}) = 2 V, and quiescent current (I_{DQ}) = 25 mA for nominal operation, unless otherwise noted.

Table 1.

Parameter	Min	Typ	Max	Unit	Test Conditions/Comments
FREQUENCY RANGE	23		27	GHz	
GAIN		28		dB	
Gain Variation over Temperature		0.023		dB/ $^\circ\text{C}$	
NOISE FIGURE		1.9		dB	
RETURN LOSS					
Input		11		dB	
Output		12		dB	
OUTPUT					
Power for 1 dB Compression (OP1dB)		7		dBm	
Saturated Output Power (P_{SAT})		9		dBm	
OIP3		16		dBm	Measurement taken at output power (P_{OUT}) per tone = -2 dBm
POWER ADDED EFFICIENCY (PAE)		14		%	Measured at P_{SAT}

FREQUENCY RANGE: 27 GHZ TO 31 GHZ

$T_C = 25^\circ\text{C}$, $V_{DD} = 2$ V, and $I_{DQ} = 25$ mA for nominal operation, unless otherwise noted.

Table 2.

Parameter	Min	Typ	Max	Unit	Test Conditions/Comments
FREQUENCY RANGE	27		31	GHz	
GAIN	23.5	26.5		dB	
Gain Variation over Temperature		0.022		dB/ $^\circ\text{C}$	
NOISE FIGURE		1.8		dB	
RETURN LOSS					
Input		21		dB	
Output		8		dB	
OUTPUT					
OP1dB	6	8.5		dBm	
P_{SAT}		10		dBm	
OIP3		20		dBm	Measurement taken at P_{OUT} per tone = -2 dBm
POWER ADDED EFFICIENCY (PAE)		17		%	Measured at P_{SAT}

DC SPECIFICATIONS

Table 3.

Parameter	Min	Typ	Max	Unit
SUPPLY CURRENT				
I_{DQ}		25		mA
Amplifier Current (I_{DQ_AMP})		22.6		mA
RBIAS Current (I_{RBIAS})		2.4		mA
SUPPLY VOLTAGE (V_{DD})	1.5	2	3.5	V

SPECIFICATIONS

RADIATION TEST AND LIMIT SPECIFICATIONS

Electrical characteristics at $V_{DD} = 2\text{ V}$, $I_{DQ} = 25\text{ mA}$, $R_{BIAS} = 499\ \Omega$, and $T_C = 25^\circ\text{C}$, unless otherwise noted. Total ionizing dose (TID) testing characterized to 30 krad, $SEL \geq 62.4\text{ MeV-cm}^2/\text{mg}$.

Table 4.

Parameter	Min	Typ	Max	Unit
FREQUENCY RANGE	27		31	GHz
GAIN	23.5	26.5		dB
OP1dB	6	8.5		dBm
SUPPLY CURRENT				
I_{DQ}		25		mA
SUPPLY VOLTAGE (V_{DD})	1.5	2	3.5	V

ABSOLUTE MAXIMUM RATINGS

Table 5.

Parameter	Rating
V_{DD}	4.0 V
RFIN	20 dBm
Continuous Power Dissipation (P_{DISS}), $T_C = 85^\circ\text{C}$ (Derate 6 mW/ $^\circ\text{C}$ Above 85°C)	0.54 W
Temperature	
Storage Range	-65°C to $+150^\circ\text{C}$
Operating Range	-55°C to $+85^\circ\text{C}$
Nominal Channel ($T_C = 85^\circ\text{C}$, $V_{DD} = 2\text{ V}$, $I_{DQ} = 25\text{ mA}$, Input Power (P_{IN}) = Off)	93.3°C
Maximum Channel	175°C

Stresses at or above those listed under Absolute Maximum Ratings may cause permanent damage to the product. This is a stress rating only; functional operation of the product at these or any other conditions above those indicated in the operational section of this specification is not implied. Operation beyond the maximum operating conditions for extended periods may affect product reliability.

THERMAL RESISTANCE

Overall thermal performance is directly linked to the carrier or substrate on which the die is mounted. Careful attention is needed with each material used in the thermal path below the IC. With an epoxy layer of nominal thickness assumed under the die, θ_{JC} is the thermal resistance from the die channel to the bottom of the epoxy layer.

Table 6. Thermal Resistance

Package Type	θ_{JC}	Unit
C-8-28	166.5	$^\circ\text{C}/\text{W}$

OUTGAS TESTING

The criteria used for the acceptance and rejection of materials must be determined by the user and based upon specific component and system requirements. Historically, a total mass loss (TML) of 1.00% and collected volatile condensable material (CVCM) of 0.10% have been used as screening levels for rejection of spacecraft materials.

Table 7. Outgas Testing

Specification (Tested per ASTM E595 -15) ¹	Value	Unit
Total Mass Lost	0.10	%
Collected Volatile Condensable Material	0.01	%
Water Vapor Recovered	0.02	%

¹ Outgas testing was performed after encapsulating the ADL8142-2C-CSL chip in the 8-lead lead frame chip scale package (LFCSP) of the ADL8142.

ELECTROSTATIC DISCHARGE (ESD) RATINGS

The following ESD information is provided for handling of ESD-sensitive devices in an ESD protected area only.

Human body model (HBM) per ANSI/ESDA/JEDDEC JS-001.

ESD Ratings for the ADL8142-2C-CSL

Table 8. ADL8142-2C-CSL, 8-Pad CHIP

ESD Model	Withstand Threshold (V)	Class
HBM	± 250	1A

ESD CAUTION



ESD (electrostatic discharge) sensitive device. Charged devices and circuit boards can discharge without detection. Although this product features patented or proprietary protection circuitry, damage may occur on devices subjected to high energy ESD. Therefore, proper ESD precautions should be taken to avoid performance degradation or loss of functionality.

PIN CONFIGURATION AND FUNCTION DESCRIPTIONS

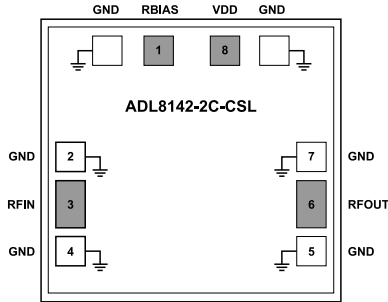

NOTES
1. DIE BOTTOM MUST BE CONNECTED TO RF AND DC GROUND. 002

Figure 2. Pad Configuration

Table 9. Pad Function Descriptions

Pad No.	Mnemonic	Description
1	RBIAS	Bias Setting Resistor. Connect a resistor between RBIAS and VDD to set the I_{DQ} . See the ADL8142-2CHIP data sheet for more details.
2, 4, 5, 7	GND	Ground. Connect the GND pins to a ground plane that has low electrical and thermal impedance.
3	RFIN	RF Input. The RFIN pin is AC-coupled and matched to 50 Ω .
6	RFOUT	RF Output. The RFOUT pin is AC-coupled and matched to 50 Ω . The RF output path is AC-coupled, but there is also a DC path to ground on the RFOUT side of the AC coupling capacitor.
8	VDD	Drain Bias. Connect the VDD pin to the supply voltage.
Die Bottom	GND	Die bottom must be connected to RF and DC ground.

TYPICAL PERFORMANCE CHARACTERISTICS

See the [ADL8142-2CHIP](#) data sheet for the typical performance characteristics plots.

OUTLINE DIMENSIONS

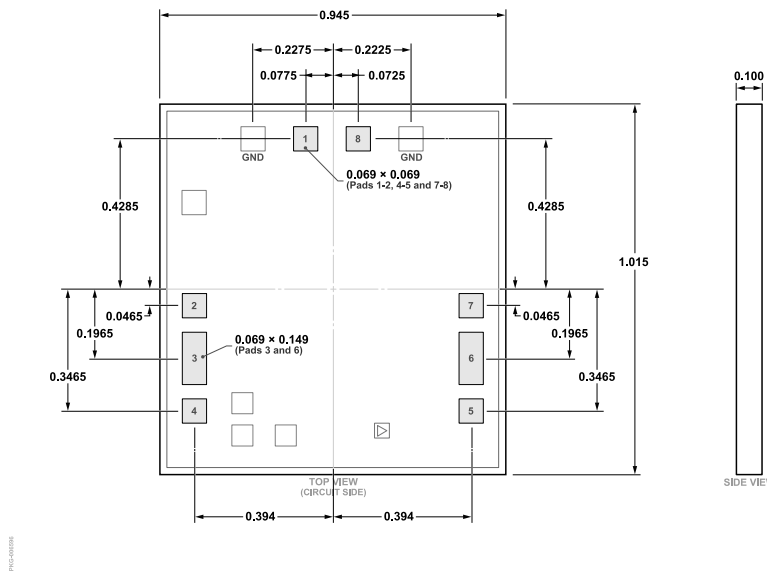

**Figure 3. 8-Pad Bare Die [CHIP]
(C-8-28)**
Dimensions shown in millimeters

Updated: October 29, 2022

ORDERING GUIDE

Model ¹	Temperature Range	Package Description	Package Option
ADL8142-2C-CSL	-55°C to +85°C	8-Pad Bare Die [CHIP]	C-8-28

¹ Z = RoHS Compliant Part.

Looking for pricing, stock, or lifecycle information?

Click below to explore more details on WIN SOURCE:

 [View ADL8142-2C-CSL on WIN SOURCE](#)

 [Analog Devices Inc. Information](#)

Optimize Your Supply Chain with WIN SOURCE Solutions

-  Global Sourcing Solution
-  Obsolete Management
-  Cost Control Management
-  Shortage Management
-  Alternative Solution
-  Excess Inventory Management