

Current Transducer HAIS 50 ... 400-P HAIS 50 ... 150-TP

$$I_{PN} = 50 \dots 400 \text{ A}$$

$$I_{PN} = 50 \dots 150 \text{ A}$$

For the electronic measurement of current: DC, AC, pulsed..., with galvanic separation between the primary circuit and the secondary circuit.



All data are given with $R_L = 10 \text{ k}\Omega$



Electrical data

	Primary nominal RMS current I_{PN} (A)	Primary current measuring range I_{PM} (A)	Type	
	50	± 150	HAIS 50-P/50-TP ¹⁾	
	100	± 300	HAIS 100-P/100-TP ¹⁾	
	150	± 450	HAIS 150-P/150-TP ¹⁾	
	200	± 600	HAIS 200-P	
	400	± 600	HAIS 400-P	
S_N	Nominal sensitivity @ I_{PN}		0.625	V / I_{PN}
U_{out}	Output voltage (Analog) @ I_P		$U_{OE} + (0.625 \cdot I_P / I_{PN}) \text{ V}$	
U_{ref}	Reference voltage ²⁾		2.5 \pm 0.025	V
	Output voltage		typ. 200	Ω
	Output impedance		≥ 200	k Ω
R_L	Load resistance		≥ 2	k Ω
R_{out}	Output internal resistance		< 5	Ω
C_L	Load capacitance ($\pm 20 \%$)		4.7	nF
U_C	Supply voltage ($\pm 5 \%$) ³⁾		5	V
I_C	Current consumption @ $U_C = 5 \text{ V}$		< 19	mA

Accuracy - Dynamic performance data

ϵ	Error ⁴⁾ @ I_{PN} , $T_A = 25 \text{ }^\circ\text{C}$	$\leq \pm 1$	% of I_{PN}
ϵ_L	Linearity error 0 ... I_{PM}	$\leq \pm 0.5$	% of I_{PN}
TCU_{OE}	Temperature coefficient of U_{OE}	$\leq \pm 0.3$	mV/K
TCU_{ref}	Temperature coefficient of U_{ref} +25 ... +85 $^\circ\text{C}$	$\leq \pm 0.01$	%/K
	-40 ... +25 $^\circ\text{C}$	$\leq \pm 0.015$	%/K
TCU_{OE}/U_{ref}	Temperature coefficient of U_{OE}/U_{ref}	$\leq \pm 0.2$	mV/K
TCS	Temperature coefficient of S	$\leq \pm 0.05 \%$	of reading/K
U_{OE}	Electrical offset voltage @ $I_P = 0$, $T_A = 25 \text{ }^\circ\text{C}$	$U_{ref} \pm 0.025$	V
U_{OM}	Magnetic offset voltage @ $I_P = 0$		
	after an overload of I_{PM}	HAIS 50-P/TP HAIS 100-P/TP ... 400-P	< ± 0.5 % of I_{PN} < ± 0.4 % of I_{PN}
t_{D10}	Delay time to 10 % of the final output value for I_{PN} step	< 3	μs
t_{D90}	Delay time to 90 % of the final output value for I_{PN} step ⁵⁾	< 5	μs
U_{no}	RMS noise voltage (DC ... 10 kHz)	< 15	mVpp
	(DC ... 1 MHz)	< 40	mVpp
BW	Frequency bandwidth (-3 dB) ⁶⁾	DC ... 50	kHz

Notes:

- 1) -TP version is equipped with a primary bus bar; Temperature of primary bus bar should not exceed 100 $^\circ\text{C}$
- 2) It is possible to overdrive U_{ref} with an external reference voltage between 1.5 V - 2.8 V providing its ability to sink or source approximately 5 mA
- 3) Maximum supply voltage (not operating) < 6.5 V
- 4) Excluding offset and magnetic offset voltage
- 5) Tested with 0 ... 125 A step with slope 100 A/ μs
- 6) Small signal only to avoid excessive heatings of the magnetic core.

Features

- Hall effect measuring principle
- Galvanic separation between primary and secondary circuit
- Insulation test voltage 2500 V
- Low power consumption
- Single power supply +5 V
- Fixed offset & sensitivity
- Insulating plastic case recognized according to UL 94-V0.

Advantages

- Small size and space saving
- Only one design for wide current ratings range
- High immunity to external interference
- U_{ref} IN/OUT.

Applications

- AC variable speed drives and servo motor drives
- Static converters for DC motor drives
- Battery supplied applications
- Uninterruptible Power Supplies (UPS)
- Switched Mode Power Supplies (SMPS)
- Power supplies for welding applications.

Application domain

- Industrial.

Current Transducer HAIS 50 ... 400-P and HAIS 50 ... 150-TP

General data

T_A	Ambient operating temperature	-40 ... +85	°C
$T_{A\text{st}}$	Ambient storage temperature	-40 ... +85	°C
m	Mass (in brackets: TP version)	20 (30)	g
	Standards	EN 50178: 1997	

Insulation coordination

U_d	RMS voltage for AC insulation test, 50 Hz, 1 min	2.5	kV
U_t	Partial discharge RMS test voltage ($q_m < 10$ pC)		
	HAIS 50 ... 400-P	> 1	kV
	HAIS 50 ... 150-TP	> 1.4	kV
U_{Ni}	Impulse withstand voltage 1.2/50 μ s	8	kV
		Min	
d_{Cp}	Creepage distance	> 8	mm
d_{Cl}	Clearance distance	> 8	mm
CTI	Comparative Tracking Index (group I)	> 600	

Applications examples

According to EN 50178 and IEC 61010-1 standards and following conditions:

- Over voltage category OV 3
- Pollution degree PD2
- Non-uniform field

	EN 50178	IEC 61010-1
d_{Cp}, d_{Cl}, U_{Ni}	Rated insulation voltage	Nominal voltage
Basic insulation	1000 V	1000 V
Reinforced insulation	600 V	300 V

Safety

This transducer must be used in limited-energy secondary circuits according to IEC 61010-1.



This transducer must be used in electric/electronic equipment with respect to applicable standards and safety requirements in accordance with the manufacturer's operating instructions.



Caution, risk of electrical shock

When operating the transducer, certain parts of the module can carry hazardous voltage (e.g. primary busbar, power supply). Ignoring this warning can lead to injury and/or cause serious damage.

This transducer is a build-in device, whose conducting parts must be inaccessible after installation. A protective housing or additional shield could be used.

Main supply must be able to be disconnected.

Dimensions HAIS 50 ... 400-P and HAIS 50 ... 150-TP (in mm)

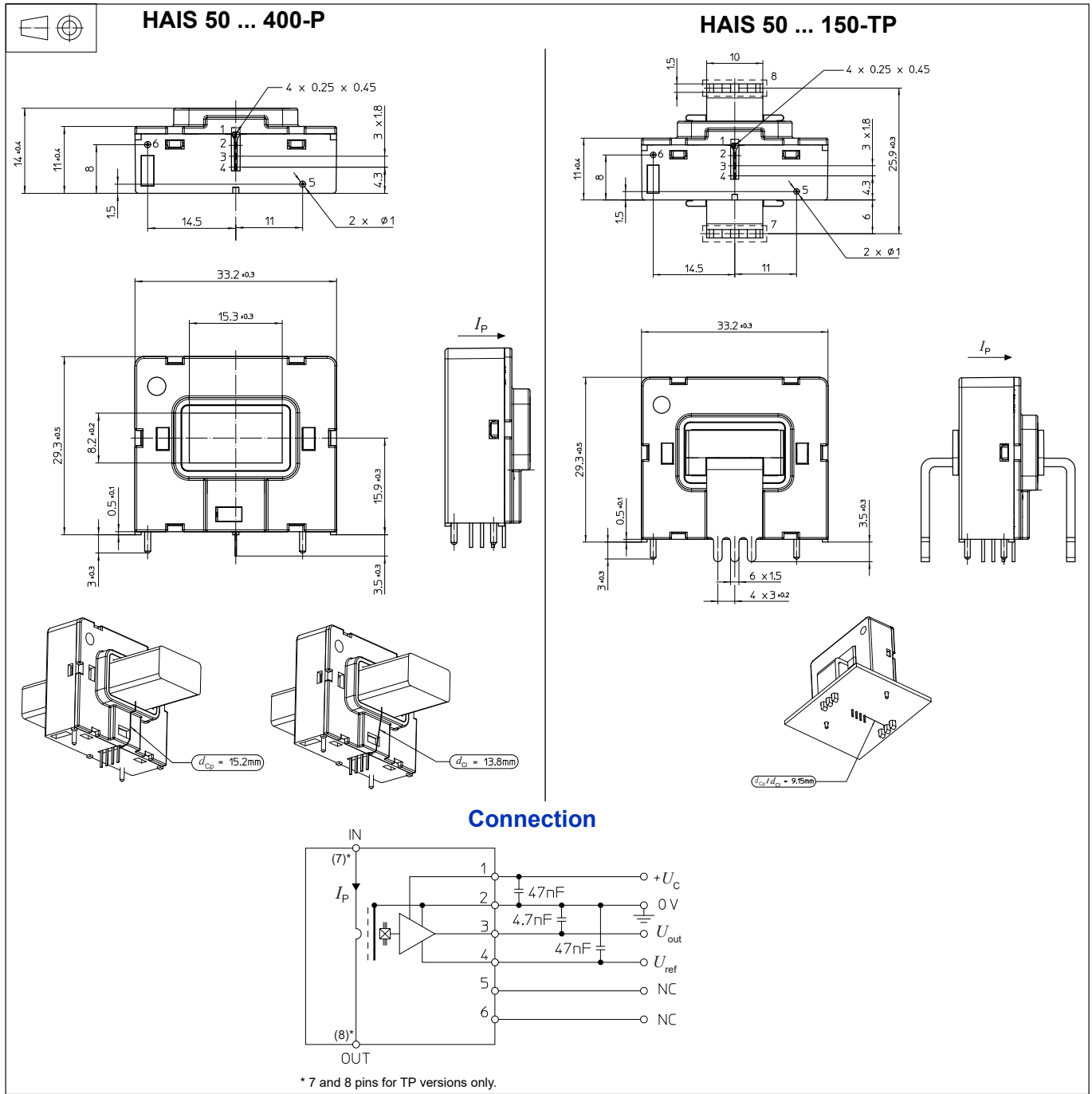

Mechanical characteristics

- General tolerance ± 0.2 mm
- Primary through-hole 15.3 mm x 8.2 mm.

Recommended PCB hole sizes

- Primary bus bar pins 7 and 8 PCB hole 2.3 ± 0.1 mm (for TP versions only)
- Secondary pins 1-4 PCB hole 0.7 ± 0.1 mm
- Support pins 5 and 6 PCB hole 1.5 ± 0.1 mm.

Remarks

- Magnetic core connected internally to 0 V for better dv/dt immunity
- U_{out} is positive when I_p flows in the direction of the arrow
- Temperature of the primary conductor should not exceed 100 °C.

IMPORTANT NOTICE

The information in this document is considered accurate and reliable. However, LEM International SA and any company directly or indirectly controlled by LEM Holding SA ("LEM") do not provide any guarantee or warranty, expressed or implied, regarding the accuracy or completeness of this information and are not liable for any consequences resulting from its use. LEM shall not be responsible for any indirect, incidental, punitive, special, or consequential damages (including, but not limited to, lost profits, lost savings, business interruption, costs related to the removal or replacement of products, or rework charges) regardless of whether such damages arise from tort (including negligence), warranty, breach of contract, or any other legal theory.

LEM reserves the right to update the information in this document, including specifications and product descriptions, at any time without prior notice. Information in this document replaces any previous versions of this document. No license to any intellectual property is granted by LEM through this document, either explicitly or implicitly. Any Information and product described herein is subject to export control regulations.

LEM products may possess either unidentified or documented vulnerabilities. It is the sole responsibility of the purchaser to design and operate their applications and products in a manner that mitigates the impact of these vulnerabilities. LEM disclaims any liability for such vulnerabilities. Customers must select products with security features that best comply with applicable rules, regulations, and standards for their intended use. The purchaser is responsible for making final design decisions regarding its products and for ensuring compliance with all legal, regulatory, and security-related requirements, irrespective of any information or support provided by LEM.

LEM products are not intended, authorized, or warranted for use in life support, life-critical, or safety-critical systems or equipment, nor in applications where failure or malfunction of an LEM product could result in personal injury, death, or significant property or environmental damage. LEM and its suppliers do not assume liability for the inclusion and/or use of LEM products in such equipment or applications; thus, this inclusion and/or use is at the purchaser's own and sole risk. Unless explicitly stated that a specific LEM product is automotive qualified, it should not be used in automotive applications. LEM does not accept liability for the inclusion and/or use of non-automotive qualified products in automotive equipment or applications.

Applications that are described herein are for illustrative purposes only. LEM makes no representation or warranty that LEM products will be suitable for a particular purpose, a specified use or application. The purchaser is solely responsible for the design and operation of its applications and devices using LEM products, and LEM accepts no liability for any assistance with any application or purchaser product design. It is purchaser's sole responsibility to determine whether the LEM product is suitable and fit for the purchaser's applications and products planned, as well as for the planned application and use of purchaser's third-party customer(s).



Stressing and using LEM products at or above limiting values will cause permanent damage to the LEM product and potentially to any device embedding or operating with LEM product. Limiting values are stress ratings only and operation of the LEM product at or above conditions and limits given in this document is not warranted. Continuous or repeated exposure to limiting values will permanently and irreversibly affect the quality and reliability of the LEM product.

LEM products are sold subject to the general terms and conditions of commercial sale, as published at www.lem.com unless otherwise agreed in a specific written agreement. LEM hereby expressly rejects the purchaser's general terms and conditions for purchasing LEM products by purchaser. Any terms and conditions contained in any document issued by the purchaser either before or after issuance of any document by LEM containing or referring to the general terms and conditions of sale are explicitly rejected and disregarded by LEM, and the document issued by the purchaser is wholly inapplicable to any sale or licensing made by LEM and is not binding in any way on LEM.

© 2025 LEM INTERNATIONAL SA – All rights reserved

Looking for pricing, stock, or lifecycle information?

Click below to explore more details on WIN SOURCE:

-  [View HAIS 200-P on WIN SOURCE](#)
-  [LEM USA Inc. Information](#)

Optimize Your Supply Chain with WIN SOURCE Solutions

-  Global Sourcing Solution
-  Obsolete Management
-  Cost Control Management
-  Shortage Management
-  Alternative Solution
-  Excess Inventory Management