

# 59145 Flange Mount Sensor

## Flange Mounting Sensor



### Description

The 59145 is a flange mounting reed sensor 28.57mm x 19.05mm x 6.35mm (1.125" x 0.750" x 0.250") with a choice of normally open, normally open high voltage, normally closed or changeover contacts. The case design enables mounting with M3 screw with washer at 1 Nm torque maximum or adhesive mounting. The wires exit from the top right-hand side, see Drawing 2. It is also available with left-hand exit - see 59150 series. The 59145 series is capable of switching up to 265Vac/300Vdc at 10VA. It is well suited for use in a wide range of industrial, appliances, or IoT proximity sensing applications.

The 59145 functions best with the matching actuator 57145-000.

### Additional Information



Resources



Accessories



Samples

### Dimensions

Dimensions in mm (inch)

Tolerances are +/- 0.25 (0.010) unless otherwise noted.

#### Drawing 1

**Actuator**  
(sold separately)

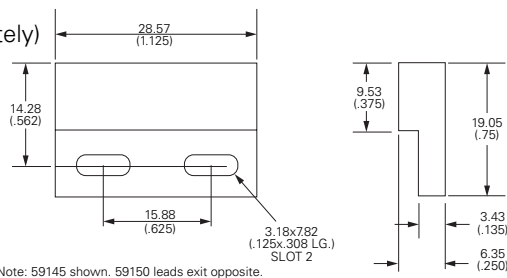

Note: 59145 shown. 59150 leads exit opposite.

#### Drawing 2

**Sensor**

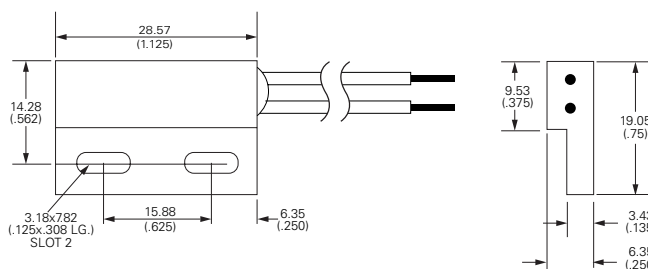

Table 1

Schematics	Switch Type
Black Black	1 and 2
Black Blue White	3
Black Black	4

### Features and Benefits

- Non-contact switching solution for wet & harsh environments
- Housing design for optimum adjustability
- Available in select sensitivities (operating distances)
- Standard cable configurations; customization options available
- Hermetically sealed, IP67 rated; UL and REACH compliant
- No leakage current in 'open' state—ideal for battery-powered IoT applications
- Can operate through non-ferrous materials (for example, wood, plastic or aluminium)
- Helps implement efficient proximity/access and energy management systems
- Compact size and easy installation and effective concealment in many applications
- UL Recognized per UL 508 and CSA C22.2 No. 14.

### Applications

- Security and access control
- Factory automation
- Process equipment
- Major appliances
- Small appliances
- Proximity and limit sensing

Table 2  
Agency Approvals

Agency	Agency File Number
	E61760

Note: Contact Littelfuse for specific agency approval ratings.

# 59145 Flange Mount Sensor

## Flange Mounting Sensor

**Table 3**  
**Electrical Ratings**

Contact Type			Normally Open	Normally Open High Voltage	Change Over	Normally Closed
Switch Type			1	2	3	4
Contact Rating <sup>1</sup>		VA/Watt - max.	10	10	5	5
Voltage <sup>4</sup>	Switching <sup>2</sup>	Vdc - max.	200	300	175	175
		Vac - max.	140	265	120	120
	Breakdown <sup>3</sup>	Vdc - min.	250	400	200	200
Current <sup>4</sup>	Switching <sup>2</sup>	Adc - max.	0.5	0.4	0.25	0.25
		Aac - max.	0.35	0.30	0.18	0.18
	Carry	Adc - max.	1.2	1.4	1.5	1.5
Resistance <sup>5</sup>	Contact, Initial Insulation	Ω - max.	0.2	0.2	0.2	0.2
		Ω - min.	10 <sup>10</sup>	10 <sup>10</sup>	10 <sup>9</sup>	10 <sup>9</sup>
Capacitance	Contact	pF - typ.	0.3	0.2	0.3	0.3
Temperature	Operating	°C	-40 to +105	-20 to +105	-40 to +105	-40 to +105

**Table 4**

Product Characteristics						
Operate Time <sup>6</sup>		ms - max.	1.0	1.0	3.0	3.0
Release Time <sup>6</sup>		ms - max.	1.0	1.0	3.0	3.0
Shock <sup>7</sup>	11ms ½ sine	G - max.	100	100	50	50
Vibration <sup>7</sup>	50-2000 Hz	G - max.	30	30	30	30

**Notes:**

- Contact rating - Product of the switching voltage and current should never exceed the wattage rating. Contact Littelfuse for additional load/life information.
- When switching inductive and/or capacitive loads, the effects of transient voltages and/or currents should be considered. Refer to Application Notes AN108A and AN107 for details.
- Breakdown Voltage - per MIL-STD-202, Method 301.
- Electrical Load Life Expectancy - Contact Littelfuse with voltage, current values along with type of load.
- This resistance value is for 300 mm wire length. Resistance changes when wire lengthens.
- Operate (including bounce)/Release Time - per EIA/NARM RS-421-A, diode suppressed coil (Coil III).
- Shock and Vibration - per EIA/NARM RS-421-A and MIL-STD-202.
- For custom modifications to the wire length or size, or adding a special connector, please contact Littelfuse.

**Table 5**  
**Sensitivity Options (Using 57145 Actuator)**

Select Option	S			T			U			V		
	Pull-In AT Range	Activation Distance (mm)	Deactivation Distance (mm)	Pull-In AT Range	Activation Distance (mm)	Deactivation Distance (mm)	Pull-In AT Range	Activation Distance (mm)	Deactivation Distance (mm)	Pull-In AT Range	Activation Distance (mm)	Deactivation Distance (mm)
1 Normally Open	12-18	9-16	11-18	17-23	7-15	8-17	22-28	6-13	8-17	27-33	5-11	7-16
2 High Voltage	-	-	-	17-23	8-15	10-18	22-28	7-13	10-17	27-33	6-12	9-16
3 Change Over	15-20	7-16	9-19	20-25	6-14	8-18	25-30	5-12	6-16	-	-	-
4 Normally Closed	15-20	7-16	9-19	20-25	6-14	8-18	25-30	5-12	6-16	-	-	-

**Notes:**

- Pull-In AT Range: These AT values are the bare reed switch AT before modification.
- The activation distance is average value on the final sensor assembly.

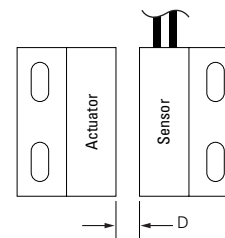

# 59145 Flange Mount Sensor

## Flange Mounting Sensor

**Table 6**  
**Cable Length Specification**

Cable Type: 24 AWG 7/32 PVC 105°C UL1430/UL1569	
Select Option	Cable Length mm (inch)
02	300 +/-10.00 (11.81 +/- 0.394)
05	1000+/-10.00 (39.37+/- 0.394)

**Table 7**  
**Termination Specification**

Termination Options	
Select Option	Description (Two-wire versions illustrated)
A	Tinned leads (6.4±0.76)mm 

**Table 8**  
**Material Specification**

	Housing Material	Color	Sealing Component
57145 Actuator	20% GF P.B.T	Black	Epoxy
59145 Sensor	20% GF P.B.T	Black	Epoxy

**Table 9**  
**Packaging**

Cable Length	Packaging Option	Quantity
02	Bulk	500
05	Bulk	500

**Part Numbering System**

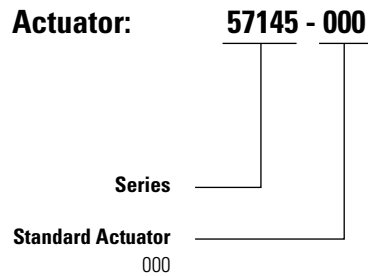
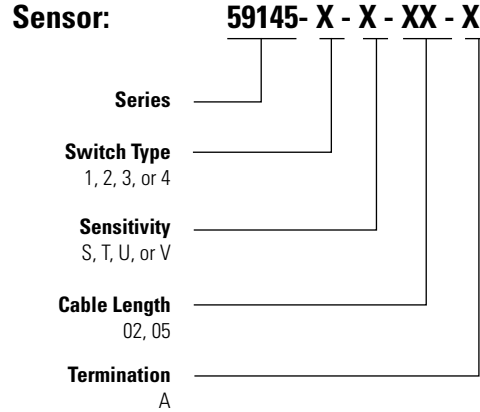

**Note:** The 57145 Actuator is sold separately.

## Looking for pricing, stock, or lifecycle information?

Click below to explore more details on WIN SOURCE:

 [View 59145-1-S-02-A on WIN SOURCE](#)

 [Littelfuse Inc. Information](#)

## Optimize Your Supply Chain with WIN SOURCE Solutions

-  Global Sourcing Solution
-  Obsolete Management
-  Cost Control Management
-  Shortage Management
-  Alternative Solution
-  Excess Inventory Management