



✓RoHS

KMXP

Linear Position Sensor

SPECIFICATIONS

- AMR linear position sensor
- DFN 2x6 package, very compact
- Small wall thickness for large air gaps
- High operating temperature of 150°C
- On the edge soldering possible

Moving a KMXP sensor along a magnetic scale will produce a sine and a cosine output signal as a function of its position. In order to deliver satisfying results, this will be achieved as long as the air gap between sensor edge and magnetic scale surface does not exceed approximately half of the pole pitch. As the sensor principle is based on the anisotropic magneto resistance effect, the signal amplitudes are nearly independent on the magnetic field strength and therefore air gap variations do not have a strong effect on the accuracy. The sensor detects a magnetic gradient field and is thus almost insensitive to homogenous stray fields.

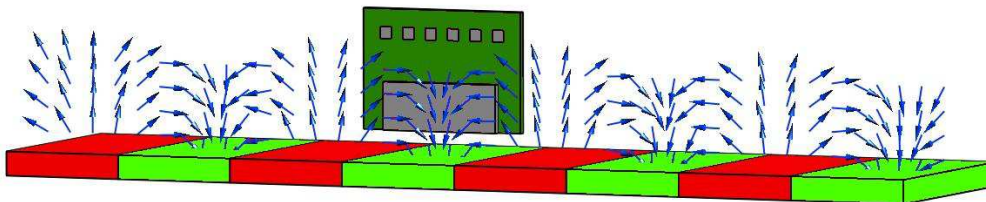

Precise displacement values will be obtained by using an amplifier in combination with a microcontroller or commercial sine/cosine interpolator device. The maximal obtainable precision depends strongly on the accuracy of the magnetic scale and on the distance sensor – magnetic scale. Precision values of <1% of the pole pitch are common.

FEATURES

- Contactless angular position measurement
- High accuracy
- Low cost, low power
- Failure detection possible
- User has total control over signal evaluation
- Extended temperature range
- REACH, 3TG & ROHS compliant

APPLICATIONS

- Measurement of linear displacements, movements, velocities in dirty environments
- Very precise angular measurement on the circumference using pole wheels
- Torque measurement in harsh environment

PERFORMANCE SPECS

PARAMETER	SYMBOL	COND.	TYPE	MIN	TYP	MAX	UNIT
1. Operating Limits							
max. supply voltage	$V_{cc,max}$		all			10	V
max. current (both bridges)	$I_{cc,max}$		KMXP 1000 KMXP 2000/5000			5 10	mA
operating temperature	T_{op}		all	-40		+150	°C
storage temperature	T_{st}		all	-40		+125	°C
2. Sensor Specifications (T=25 °C)							
Supply voltage	V_{cc}		all		5		V
pole pitch 1)	p		KMXP 1000 KMXP 2000 KMXP 5000		1000 2000 5000		μm
Air gap package front – magnetic scale 2)	D		KMXP 1000 KMXP 2000 KMXP 5000	0.1 0.2 0.5	0.4 0.8 2	0.8 1.8 4	mm
Resistance (both bridges)	R_b		KMXP 1000 KMXP 2000/5000	2000 1000	3000 1500	4000 2000	Ω
Output signal range	$\Delta V_n/V_{cc}$	A, B	all	18	22	26	mV/V
Offset voltage	$V_{n\ off}$	A, B	all	-1	0	+1	mV/V
3. Sensor Specifications							
TC of amplitude	TCSV	A, C	All		-0.35		%/K
TC of resistance	TCBR	A, C	All		+0.35		%/K
TC of offset	TCVoff	A, C	all	-4	0	+4	μV/V/K

$n = 1;2$ (bridge number); Stress above one or more of the limiting values may cause permanent damage to the device. Exposure to limiting values for extended periods may affect device reliability.

1) Other pole pitches on request

2) Typical values for conventional magnetic scales. Air gap for maximum accuracy depends on the used scale.

MEASUREMENT SET UP CONDITIONS

PARAMETER	SYMBOL	UNIT	CONDITION
A. Set Up Conditions			
ambient temperature	T	°C	$T = 25\text{ °C}$ (unless otherwise noted)
supply voltage	V_{cc}	V	$V_{cc} = 5\text{ V}$
applied magnetic field	H	kA/m	$H > 10\text{ kA/m}$
B. Sensor Specifications (T=25 °C, 360° turn , H=25 kA/m , $V_{o\max}>0$, $V_{o\min}<0$)			
output signal range	$\Delta V_n / V_{cc}$	mV/V	$\Delta V_n / V_{cc} = (V_{n\ max} - V_{n\ min}) / V_{cc}$
signal offset	$V_{off\ n}$	mV/V	$V_{off\ n} = (V_{n\ max} + V_{n\ min}) / V_{cc}$

C. Sensor Specifications (T=-25°C, +125°C)			
ambient temperatures	T	°C	T ₁ = -25 °C, T ₀ = +25 °C, T ₂ = +125 °C
TC of amplitude	TCSV	%/K	$TCV = \frac{1}{(T_2 - T_1)} \cdot \frac{\frac{\Delta V_n(T_2)}{V_{cc}} - \frac{\Delta V_n(T_1)}{V_{cc}}}{\frac{\Delta V_n(T_1)}{V_{cc}}} \cdot 100\%$
TC of resistance	TCBR	%/K	$TCR = \frac{1}{(T_2 - T_1)} \cdot \frac{R_n(T_2) - R_n(T_1)}{R_n(T_1)} \cdot 100\%$
TC of offset	TCVoff	µV/(VK)	$TCVoff_n = \frac{Voff_n(T_2) - Voff_n(T_1)}{(T_2 - T_1)}$

n = 1;2 (bridge number)

BLOCK DIAGRAM

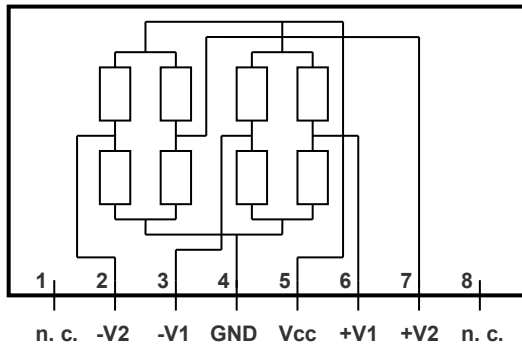

Figure 1a: KMXP 1000/2000

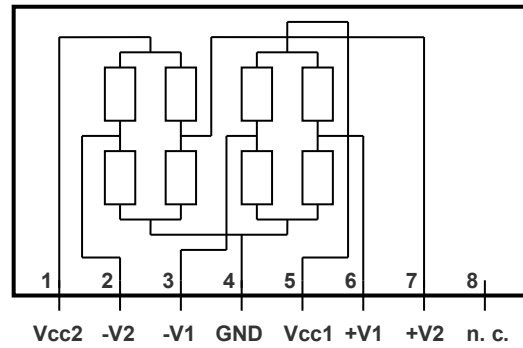

Figure 1b: KMXP 5000

TYPICAL PERFORMANCE CURVES

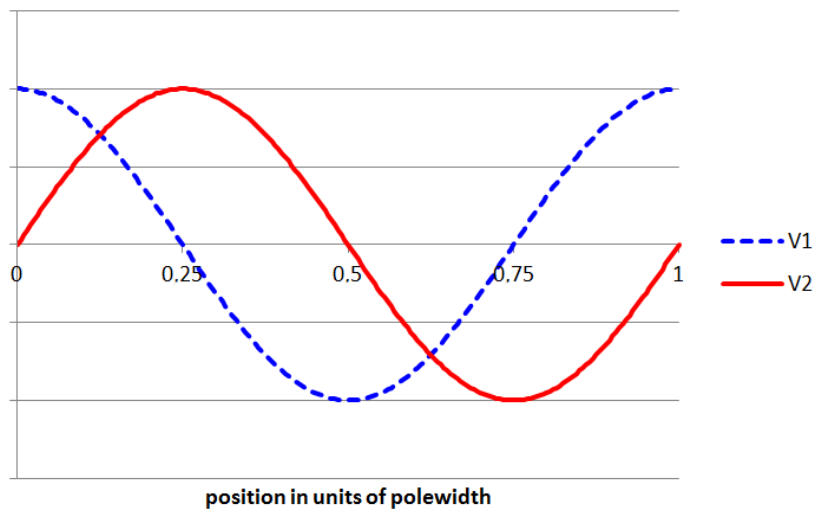

Figure 2: typical output signal voltage depending on sensor position

FUNCTION

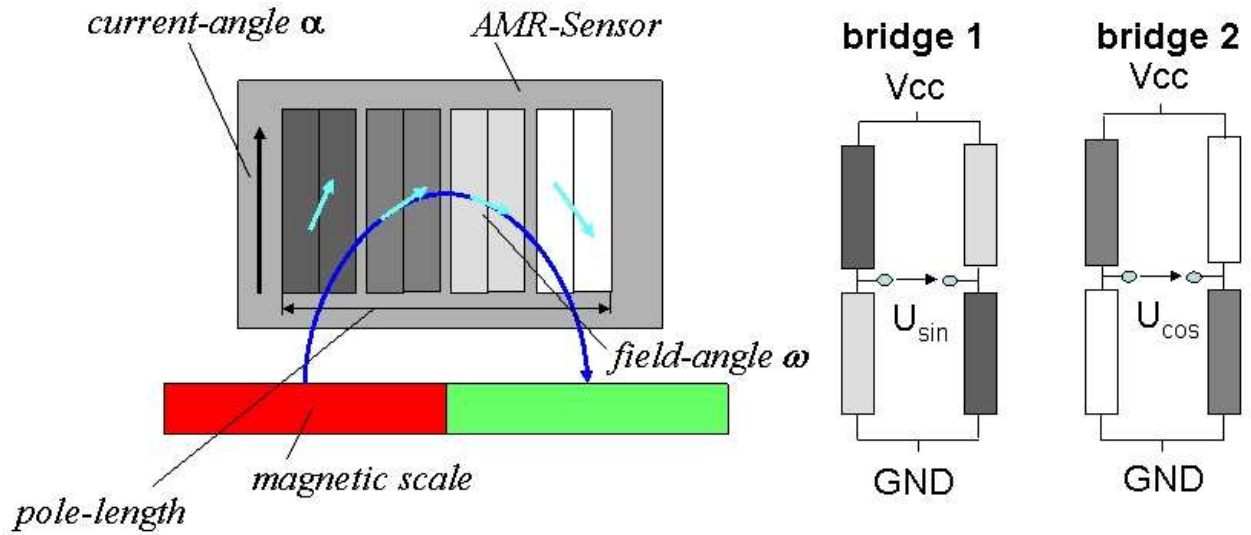
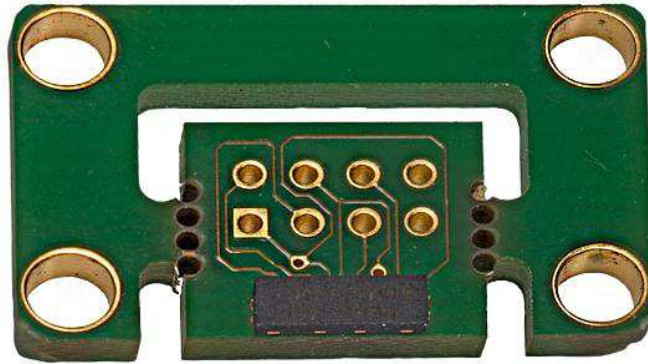

Figure 3: principle function of the sensor

The KMXP sensors consists of two magneto resistive Wheatstone bridges, whose resistors are placed in a way that the characteristic magnetic field distribution of a magnetic scale with matching pole pitch produces a sine and a cosine signal output, when the sensor is moved along the scale. In addition, some sensor types integrate over more than one pole in order to improve sensor performance.

EXAMPLE FOR A PRINTED CIRCUIT BOARD ASSEMBLY



PIN ASSIGNMENT

The pin assignment is pin compatible for all KMXP types and allows a common PCB layout for all types:

Pin	1	2	3	4	5	6	7	8	9	10	11	12
KMXP5000	Vcc2	-V2	-V1	GND	Vcc1	+V1	+V2	N/C	N/C	N/C	N/C	N/C
KMXP2000	N/C	-V2	-V1	GND	Vcc	+V1	+V2	N/C	N/C	N/C	N/C	N/C
KMXP1000	N/C	-V2	-V1	GND	Vcc	+V1	+V2	N/C	N/C	N/C	N/C	N/C

PHYSICAL DIMENSIONS

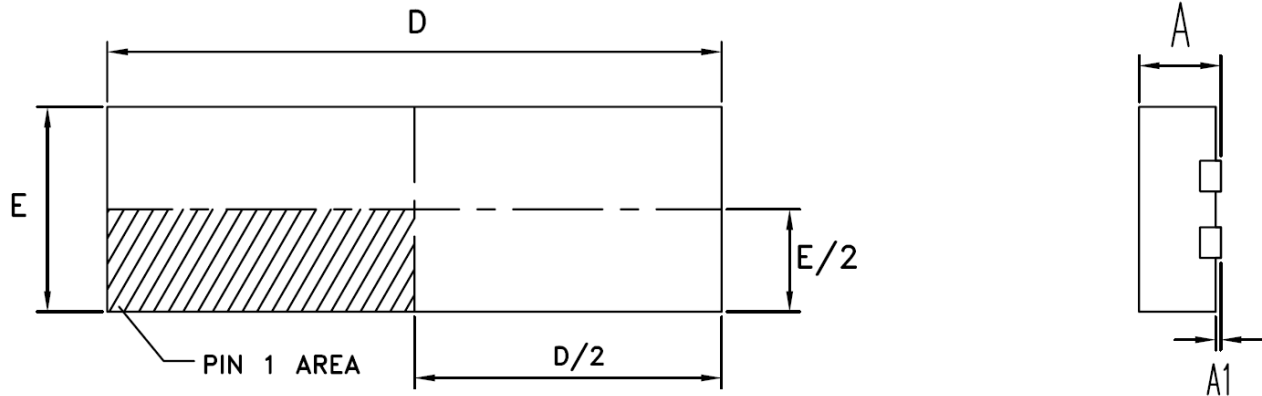

JEDEC#	NOT APPLICABLE			
TYPE	12 TDLM			
Dimension	mm		mils	
SYMBOL	Min	Max	Min	Max
A	0.70	0.80	27.56	31.50
A1	0	0.05	0	1.97
A3	0.15	0.25	5.91	9.84
D	5.9	6.1	232.28	240.16
E	1.9	2.1	74.8	82.68
D2	4.85	4.95	190.94	194.88
E2	1.25	1.35	49.21	53.15
e	0.65 BSC		25.59 BSC	
NX b	0.25	0.35	9.84	13.78
NX L	0.25	0.35	9.84	13.78
θ°	0°	4°	0°	4°
ND	8 (One side only)			
NE	2			

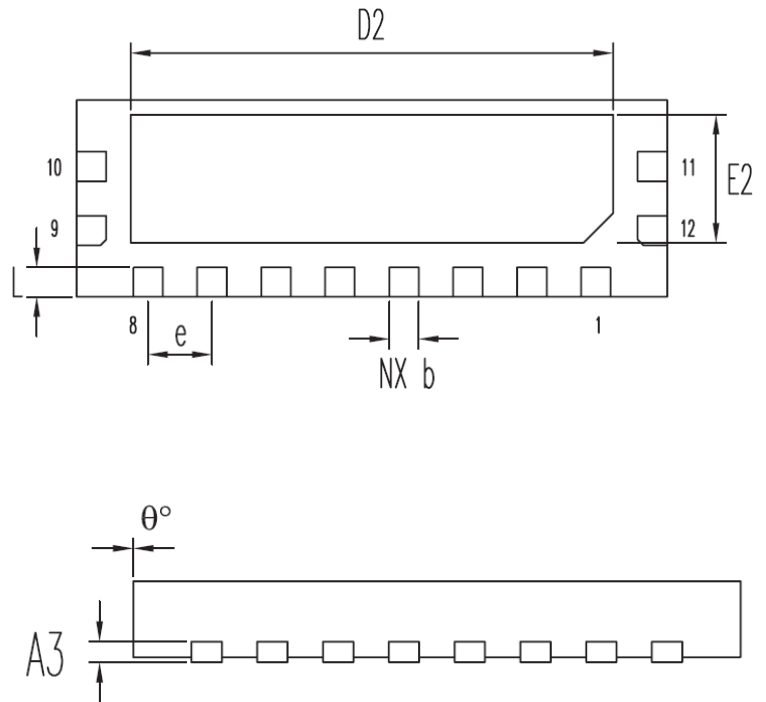

Fig. 4: Physical dimensions of sensor package

Reflow profile for this package according to IPC/JEDEC J-STD-020 Revision D.1 (March 2008).

APPLICATION EXAMPLE

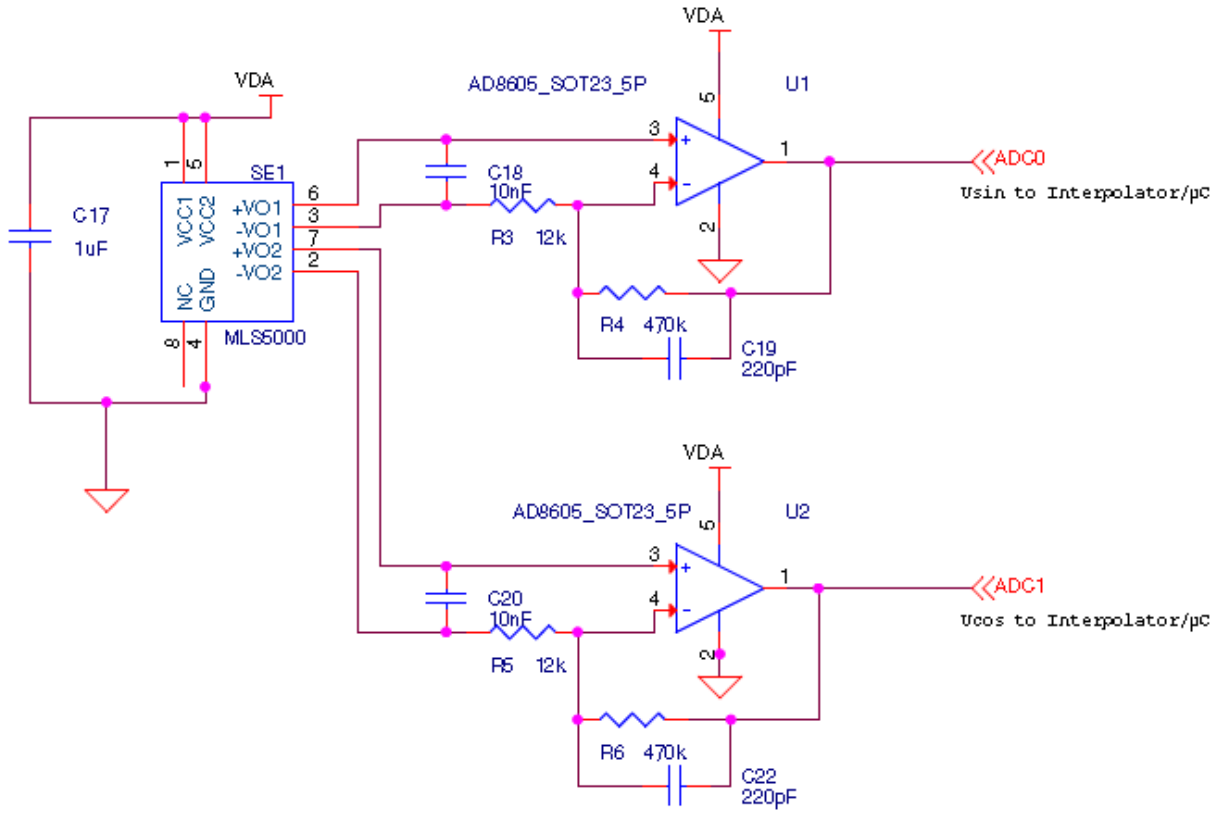

Fig. 5: Exemplary hardware configuration for the usage with a conventional microcontroller using an Analog Devices AD8605 amplifier for the preprocessing of the sensor signals.

ORDERING CODE

Name	KMXP1000	KMXP2000	KMXP5000
Pole pitch	1 mm	2 mm	5 mm
Article number	<i>on request</i>	G-MRCO-050	G-MRCO-052

NORTH AMERICA

Measurement Specialties, Inc.,
a TE Connectivity Company
Phone: +1-800-522-6752
Email: customercare.hmpt@te.com

EUROPE

MEAS Deutschland GmbH (Europe)
a TE Connectivity Company
Phone: +49-800-440-5100
Email: customercare.dtmnd@te.com

ASIA

Measurement Specialties (China), Ltd.,
a TE Connectivity Company
Phone: +86-400-820-6015
Email: customercare.shzn@te.com

TE.com/sensorsolutions

Measurement Specialties, Inc., a TE Connectivity company.

Measurement Specialties, TE Connectivity, TE Connectivity (logo) and EVERY CONNECTION COUNTS are trademarks. All other logos, products and/or company names referred to herein might be trademarks of their respective owners.

The information given herein, including drawings, illustrations and schematics which are intended for illustration purposes only, is believed to be reliable. However, TE Connectivity makes no warranties as to its accuracy or completeness and disclaims any liability in connection with its use. TE Connectivity's obligations shall only be as set forth in TE Connectivity's Standard Terms and Conditions of Sale for this product and in no case will TE Connectivity be liable for any incidental, indirect or consequential damages arising out of the sale, resale, use or misuse of the product. Users of TE Connectivity products should make their own evaluation to determine the suitability of each such product for the specific application.

© 2015 TE Connectivity Ltd. family of companies All Rights Reserved.

Looking for pricing, stock, or lifecycle information?

Click below to explore more details on WIN SOURCE:

 [View G-MRCO-050](#) on WIN SOURCE

 [TE Connectivity](#) Information

Optimize Your Supply Chain with WIN SOURCE Solutions

-  Global Sourcing Solution
-  Obsolete Management
-  Cost Control Management
-  Shortage Management
-  Alternative Solution
-  Excess Inventory Management