

# TLE4959C Transmission Speed Sensor

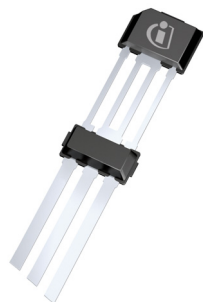

## Features

- Hall based differential speed sensor
- High magnetic sensitivity
- Large operating airgap
- Dynamic self-calibration principle
- Adaptive hysteresis
- Direction of rotation detection
- High vibration suppression capabilities
- Three wire PWM voltage interface
- Magnetic encoder and ferromagnetic wheel application
- High immunity against ESD, EMC and mechanical stress, improved voltage dropout capability
- Automotive operating temperature range
- 3-pin package PG-SSO-3-52
- Green Product (RoHS compliant)
- AEC Qualified

## Applications

The TLE4959C is an integrated differential Hall speed sensor ideally suited for transmission applications. Its basic function is to provide information about rotational speed and direction of rotation to the transmission control unit. TLE4959C includes a sophisticated algorithm which actively suppresses vibration while keeping excellent airgap performance.

**Table 1 Description**

Type	Marking	Ordering Code	Package
TLE4959C	59AIC0	SP001671650	PG-SSO-3-52

## Description

The TLE4959C comes in a RoHs compliant three-pin package, qualified for automotive usage. It has two integrated capacitors on the lead frame (220 nF/1.8 nF). These capacitors increase the EMC robustness of the device. In 12 V applications it is further recommended to use a serial resistor  $R_{Supply}$  of 100  $\Omega$  (tbd) for protection on the supply line. A pull-up resistor  $R_{Load}$  is mandatory on the output pin and determines the maximum current flowing through the output transistor. A value of 1.2 k $\Omega$  is recommended for the 5V application. (see [Figure 1](#))

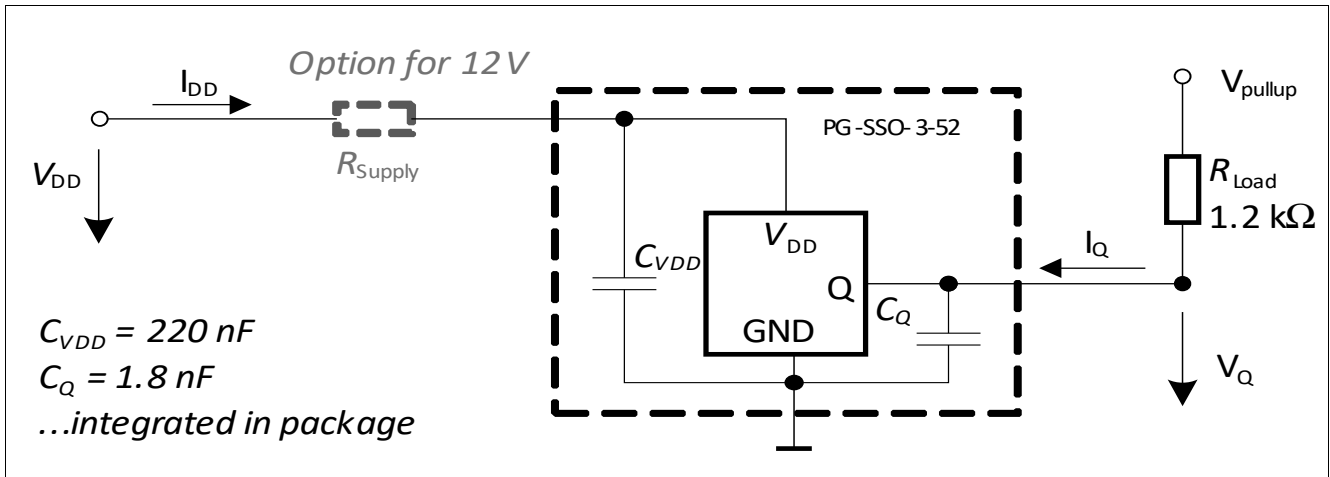

Figure 1 Typical Application Circuit

Functional Description

# 1 Functional Description

The differential Hall sensor IC detects the motion of tooth and magnet encoder applications. To detect the motion of ferromagnetic objects, the magnetic field must be provided by a back biasing permanent magnet. Either south or north pole of the magnet can be attached to the rear unmarked side of the IC package (See [Figure 2](#)). The magnetic measurement is based on three equally spaced Hall elements, integrated on the IC. Both magnetic and mechanical offsets are cancelled by a self calibration algorithm. The sensor includes a voltage output PWM protocol.

## 1.1 Definition of the Magnetic Field Direction

The magnetic field of a permanent magnet exits from the north pole and enters the south pole. If a north pole is attached to the backside of the High End Transmission Sensor, the field at the sensor position is positive, as shown in [Figure 2](#).

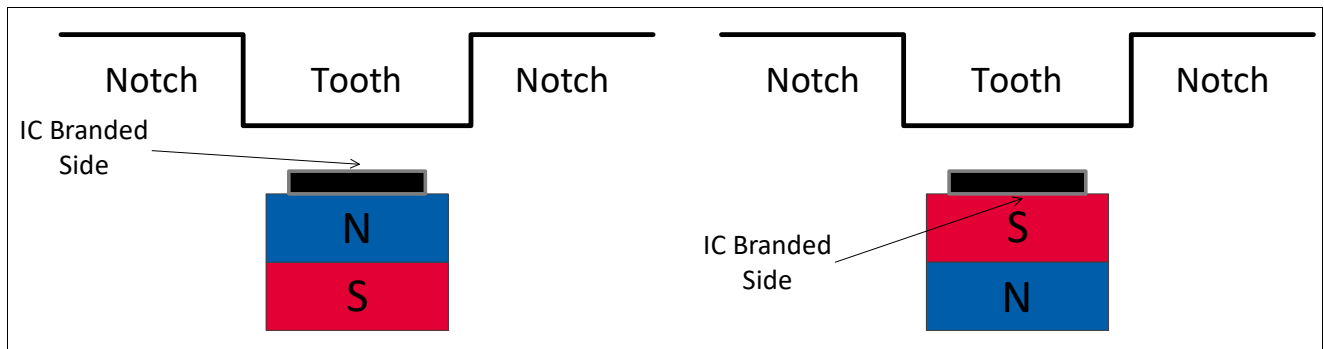

Figure 2 Definition of the Positive Magnetic Field Direction

## 1.2 Block Diagram

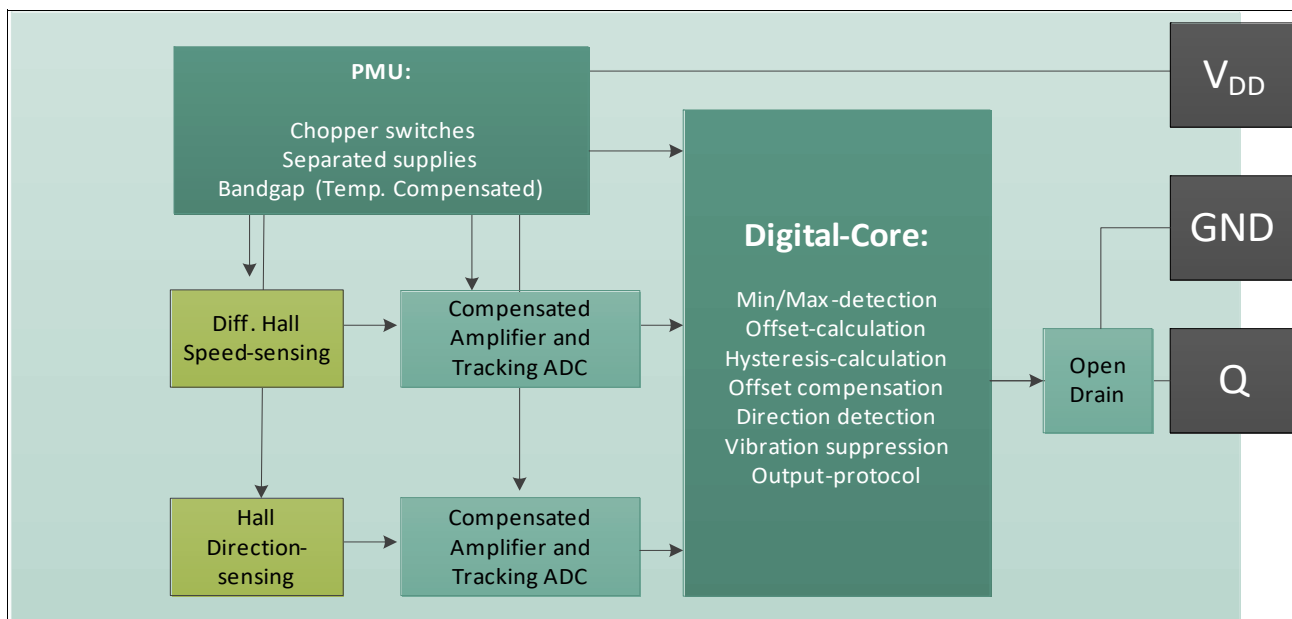

Figure 3 Block Diagram

Functional Description

1.3 Basic Operation

The speed signal calculated out of the differential hall elements, is amplified, filtered and digitized. An algorithm in the digital core for peak detection and offset calculation will be executed. The offset is fed back into the speed signal path with a digital to analog converter for offset correction. During uncalibrated mode, the output of the speed pulse is triggered in the digital core by exceeding a certain threshold of the tracking ADC. In calibrated mode the output is triggered by the visible hysteresis.

The direction signal is calculated out of center Hall signals. The direction signal is amplified, filtered, and digitized. In the digital core the direction and the vibration detection information is determined and the output protocol is issued.

1.4 Uncalibrated and Calibrated Mode

After power on the differential magnetic speed signal is tracked by an analog to digital converter (Tracking ADC) and monitored within the digital core. If the signal slope is identified as a rising edge or falling edge, the first output pulse is triggered. A second trigger pulse is issued with direction information.

In uncalibrated mode, the output protocols are triggered by the DNC (detection noise constant) in the speed path. After start up the sensor switches with the DNC min value and after that the DNC is adapted to the magnetic input signal amplitude.

The offset update starts if two valid extrema values are found and the direction of the update has the same orientation as the magnetic signal. For example, a positive offset update is being issued on a rising magnetic edge only. After a successful offset correction, the sensor is in calibrated mode. Switching occurs at the adaptive hysteresis threshold level.

In calibrated mode, the DNC is adapted to magnetic input signal amplitude with a minimum of  $\Delta B_{limit}$ . The output pulses are then triggered with adaptive hysteresis.

1.5 Hysteresis Concept

The adaptive hysteresis is linked to the input signal. Therefore, the system is able to suppress switching if vibration or noise signals are smaller than the adaptive hysteresis levels. The typical value for the hysteresis level is 1/4 of the magnetic input signal amplitude, the minimum hysteresis level is  $\Delta B_{limit}$ .

The visible hysteresis keeps the excellent performance in large pitch transmission application wheels.

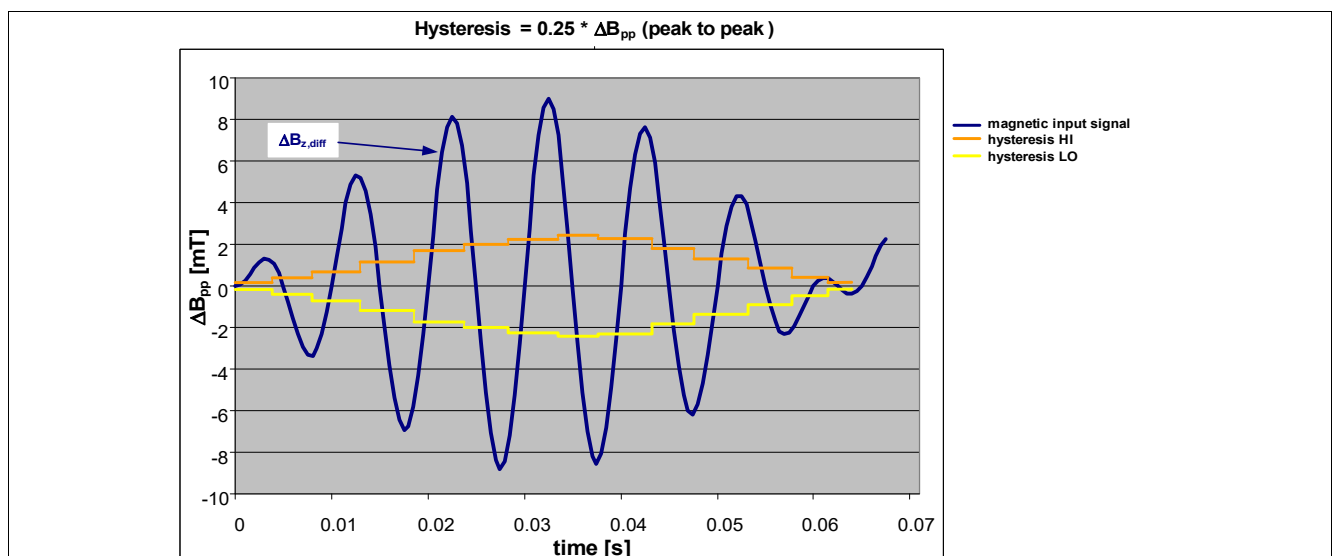

Figure 4 Adaptive Hysteresis

Functional Description

1.6 Rotational Direction

The direction signal is digitized by an analog to digital converter (direction ADC) and fed into the digital core. Depending upon the rotation direction of the target wheel, the signal of the center probe anticipates or lags behind for 90°. This phase relationship is evaluated and converted into rotation direction information by sampling the signal of the center probe in the proximity of the zero crossing of the “speed” bridge signal.

The first pulse after power (power on pulse) has a different length to signalize that there is no direction information available.

Forward pulse ( $t_{fwd}$ ) is issue if the wheel rotates from pin 1 to pin 3

Backward pulse ( $t_{bwd}$ ) is issue if the wheel rotates from pin 3 to pin 1

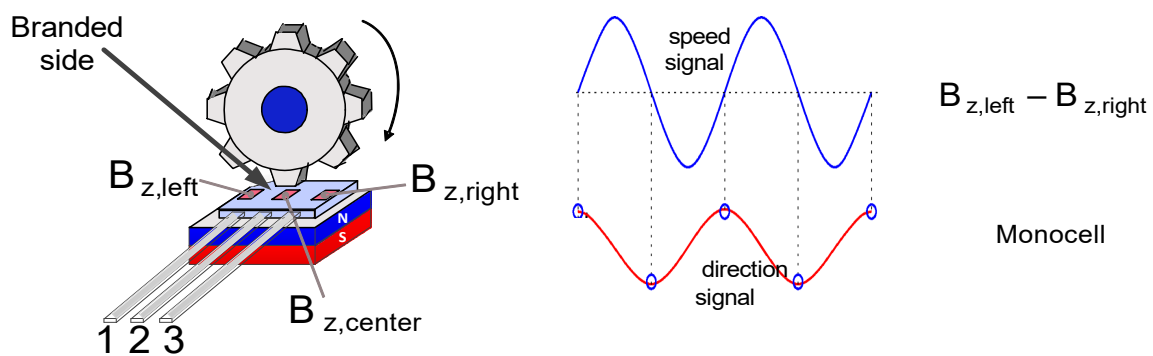

Figure 5 Direction definition

1.7 Vibration Suppression

The magnetic signal amplitude and the direction information are used for detection of parasitic magnetic signals. Unwanted magnetic signal can be caused by angular or air gap vibrations. If an input signal is identified as a vibration the output pulse will be suppressed.

## General Characteristics

## 2 General Characteristics

### 2.1 Absolute Maximum Ratings

**Table 2 Absolute Maximum Ratings**

Parameter	Symbol	Values			Unit	Note or Test Condition
		Min.	Typ.	Max.		
Supply voltage without supply resistor	$V_{DD}$	-16	-	18	V	continuous, $T_J \leq 175^\circ\text{C}$
				27	V	max. 60 s, $T_J \leq 175^\circ\text{C}$
		-18			V	max. 60 s, $T_J \leq 175^\circ\text{C}$
Output OFF voltage	$V_{Q\_OFF}$	-1.0	-		V	max. 1 h, $T_{Amb} \leq 40^\circ\text{C}$
		-0.3	-	26.5	V	continuous, $T_J \leq 175^\circ\text{C}$
Output ON voltage	$V_{Q\_ON}$	-	-	16	V	continuous, $T_{Amb} \leq 40^\circ\text{C}$
		-	-	18	V	max. 1 h, $T_{Amb} \leq 40^\circ\text{C}$
		-	-	26.5	V	max. 60 s, $T_{Amb} \leq 40^\circ\text{C}$
Junction temperature range	$T_J$	-40	-	185	$^\circ\text{C}$	exposure time: max. $10 \times 1$ h, $V_{DD} = 16\text{V}$
Magnetic field induction	$B_Z$	-5	-	5	T	magnetic pulse during magnet magnetization. valid 10 s with $T_{ambient} \leq 80^\circ\text{C}$
ESD compliance	$ESD_{HBM}$	-6	-	6	kV	HBM <sup>1)</sup>

1) ESD susceptibility, HBM according to EIA/JESD 22-A114B

**Note:** Stresses above the max values listed here may cause permanent damage to the device. Exposure to absolute maximum rating conditions for extended periods may affect device reliability. Maximum ratings are absolute ratings; exceeding only one of these values may cause irreversible damage to the integrated circuit.

### 2.2 Operating Range

All parameters specified in the following sections refer to these operating conditions unless otherwise specified.

**Table 3 General Operating Conditions**

Parameter	Symbol	Values			Unit	Note or Test Condition
		Min.	Typ.	Max.		
Supply voltage without supply resistance $R_s$	$V_{DD}$	4.0	-	16	V	
Continuous Output Off voltage	$V_{Q\_OFF}$	-	-	16	V	
Supply voltage power- up/down voltage ramp	$dV_{DD}/dt$	3.0	-	1e4	V/ms	
Supply current	$I_{DD}$	8.0	-	13.4	mA	
Continuous output On current	$I_{Q\_ON}$		-	15	mA	$V_{Q\_LOW} < 0.5\text{V}$

General Characteristics

**Table 3** General Operating Conditions (cont'd)

Parameter	Symbol	Values			Unit	Note or Test Condition
		Min.	Typ.	Max.		
Capacitance between IC supply & ground pins	$C_{VDD}$	198	220	242	nF	capacitor type X8R, rated voltage =50 V <sup>1)</sup>
Output capacitance between IC output and ground pins	$C_Q$	1.62	1.8	1.98	nF	capacitor type X8R, rated voltage =50 V <sup>1)</sup>
Frequency range for direction detection (hysteresis)	$f_{Dir}$	0	-	1800	Hz	for increasing rotational frequency
		0	-	1500	Hz	for decreasing rotational frequency
Magnetic signal frequency range	$f$	0	-	10	kHz	
Dynamic range of the magnetic field of the differential speed channel	$DR_{mag\_field\_s}$	-120	-	120	mT	ADC-range
Dynamic range of the magnetic field of the direction channel	$DR_{mag\_field\_dir}$	-60	-	60	mT	ADC-range
Static range of the magnetic field of the outer Hall probes in back-bias configuration	$SR_{mag\_field\_s}$	0	-	550	mT	no wheel in front of module /Offset-DAC-Compensation-range
Static range of the magnetic field of the center Hall probe	$DR_{mag\_field\_dir}$	-100	-	450	mT	no wheel in front of module /Center-Offset-DAC-Compensation-range
Allowed static difference between outer probes	$SR_{mag\_field\_diff}$	-30	-	30	mT	no wheel in front of module
Normal operating junction temperature	$T_J$	-40	-	175	°C	exposure time: max. 2500 h at $T_J = 175^\circ\text{C}$ , $V_{DD} = 16\text{ V}$
		-	-	185	°C	exposure time: max. 10 × 1 h at $T_J = 185^\circ\text{C}$ , $V_{DD} = 16\text{ V}$ , additive to other lifetime
Not operational lifetime	$T_{no}$	-40		150	°C	without sensor function. Exposure time max 500 h @ 150°C; increased time for lower temperatures according to Arrhenius-Model, additive to other lifetime
Temperature compensation range of magnetic material	$TC$		-600		ppm	internal compensation of magnetic signal amplitude of speed signal

1) Specified at room temperature, test condition at 25°C with 1V at 1kHz, temperature variation to be added

Note: In the operating range the functions given in the functional description are fulfilled

## Electrical and Magnetic Characteristics

### 3 Electrical and Magnetic Characteristics

All values specified at constant amplitude and offset of input signal, over operating range, unless otherwise specified. Typical values correspond to  $V_S = 5\text{ V}$  and  $T_{\text{Amb.}} = 25^\circ\text{C}$

**Table 4 Electrical and Magnetic Parameters**

Parameter	Symbol	Values			Unit	Note or Test Condition
		Min.	Typ.	Max.		
Output saturation voltage	$V_{Q\text{sat}}$	0	-	500	mV	$I_Q \leq 15\text{ mA}$
Clamping voltage $V_{DD}$ -Pin	$V_{DD\_clamp}$	42		-	V	leakage current through ESD diode $< 0.5\text{mA}$
Clamping voltage $V_Q$ -Pin	$V_{Qclamp}$	42		-	V	leakage current through ESD diode $< 0.5\text{mA}$
Reset voltage	$V_{DD\_reset}$	2.8		3.6	V	
Output leakage current	$I_{Qleak}$	0	0.1	10	$\mu\text{A}$	$V_Q = 18\text{ V}$
Output current limit during short-circuit condition	$I_{Qshort}$	30	-	80	mA	
Junction temperature limit for output protection	$T_{prot}$	190	-	205	$^\circ\text{C}$	
Power on time	$t_{\text{power\_on}}$	0.8	0.9	1	ms	during this time the output is locked to high.
Delay time between magnetic signal switching point and corresponding output signal falling edge switching event	$t_{\text{delay}}$	10	14	19	$\mu\text{s}$	falling edge
Output fall time	$t_{\text{fall}}$	2.0	2.5	3.0	$\mu\text{s}$	$V_{\text{Pullup}} = 5\text{ V}$ , $R_{\text{Pullup}} = 1.2\text{ k}\Omega$ (+/-10%), $C_Q = 1.8\text{ nF}$ (+/-15%), valid between 80% - 20%
		3.2	4.5	5.8	$\mu\text{s}$	$V_{\text{Pullup}} = 5\text{ V}$ , $R_{\text{Pullup}} = 1.2\text{ k}\Omega$ (+/-10%), $C_Q = 1.8\text{ nF}$ (+/-15%), valid between 90% - 10%
Output rise time	$t_{\text{rise}}^{1)2)}$	4	-	11.4	$\mu\text{s}$	$R_{\text{Pullup}} = 1.2\text{ k}\Omega$ (+/-10%), $C_Q = 1.8\text{ nF}$ (+/-15%), valid between 10% - 90%
Digital noise constant of speed channel during start up	$DNC_{\text{min}}$	1.22	1.5	1.78	mT	
Period Jitter, $f \leq 8\text{ kHz}^{3)}$	$Jit_{8\text{kHz}}$	-1	-	1	%	1 sigma, $\Delta B_{\text{pkpk}} = 3\text{mT}$
Period Jitter, $8\text{ kHz} \leq f \leq 10\text{ kHz}^{3)}$	$Jit_{10\text{kHz}}$	-1.1		1.1	%	1 sigma, $\Delta B_{\text{pkpk}} = 3\text{mT}$
Number of wrong pulses at start-up	$n_{\text{Start}}$	-	-	0	n	in forward rotational direction
		0	-	1	n	in backward rotational direction

Electrical and Magnetic Characteristics

**Table 4 Electrical and Magnetic Parameters (cont'd)**

Parameter	Symbol	Values			Unit	Note or Test Condition
		Min.	Typ.	Max.		
Global run out <sup>4)</sup>	$Runout_{global, speed}$	0	–	40	%	of magnetic speed signal amplitude
		0	–	60	%	of magnetic speed signal amplitude with reduced performance on stand-still functionality
	$Runout_{global, dir}$	0	–	40	%	of magnetic direction signal amplitude
		0	–	60	%	of magnetic direction signal amplitude with reduced performance on stand-still functionality
Tooth to tooth run out (peak to peak variation on two consecutive teeth / pole-pair) <sup>4)</sup>	$Runout_{tooth, speed}$	0	–	40	%	of magnetic speed signal amplitude
	$Runout_{tooth, dir}$	0	–	40	%	of magnetic direction signal amplitude
Sudden airgap jump	$S_{AJ}$	1			mm	<sup>5)</sup>
Output protocol in forward direction	$t_{fwd}$	38	45	52	μs	$V_{Pullup} = 5 V, R_{Pullup} = 1.2 k\Omega (+/- 10\%), C_Q = 1.8 nF (+/- 15\%),$ valid between 50% of falling edge to 50% of next rising edge
Output protocol in backward direction	$t_{bwd}$	76	90	104	μs	
Power on pulse	$t_{power-on}$	153	180	207	μs	

- 1) Value of capacitor: 1.8 nF±10%; ceramic: X8R; maximum voltage: 50 V
- 2) Application parameter, IC shall not increase the rise time, Values are calculated and not tested
- 3) Parameter not subject to productive test. Verified by lab characterization based on jitter-measurement > 1000 periods
- 4) Defined as 1-(amplitude\_min/amplitude\_max)
- 5) No additional lost/pulse due to specified sudden airgap jump. No offset change and/or previous vibration considered.

**Note:** *The listed Electrical and magnetic characteristics are ensured over the operating range of the integrated circuit. Typical characteristics specify mean values expected over the production spread. If not other specified, typical characteristics apply at  $T_{Amb} = 25^{\circ}C$  and  $V_S = 5 V$ .*

Package Information

### 4 Package Information

Pure tin covering (green lead plating) is used. The product is RoHS (Restriction of Hazardous Substances) compliant and marked with letter G in front of the data code marking and may contain a data matrix code on the rear side of the package (see also information note 136/03). Please refer to your key account team or regional sales if you need further information.

The specification for soldering and welding is defined in the latest revision of application note "Recommendation for Board Assembly-Hallsensor SSO Packages".

#### 4.1 Package Outline

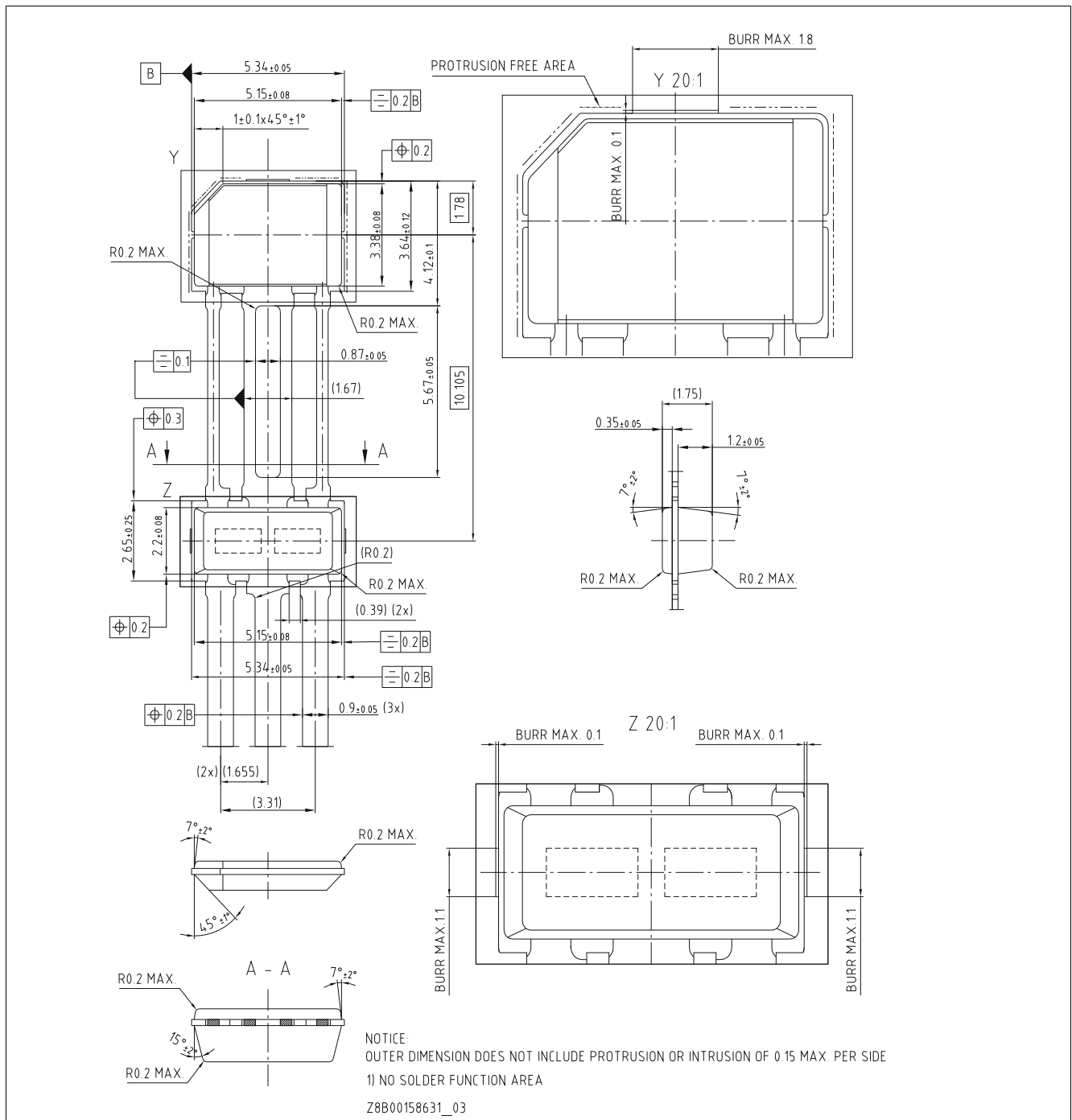

Figure 6 PG-SSO-3-52 (Plastic Green Single Slim Outline), Package Dimensions

Package Information

4.2 Position of the Hall Element

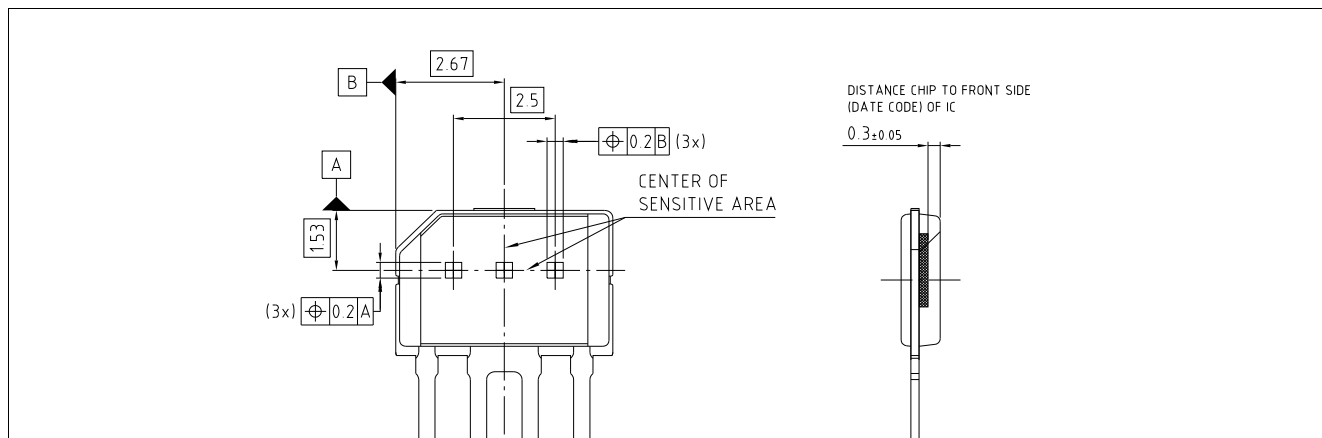

Figure 7 Position of the Hall Elements in PG-SSO-3-52 and Distance to the Branded Side

4.3 Marking and Data Matrix Code

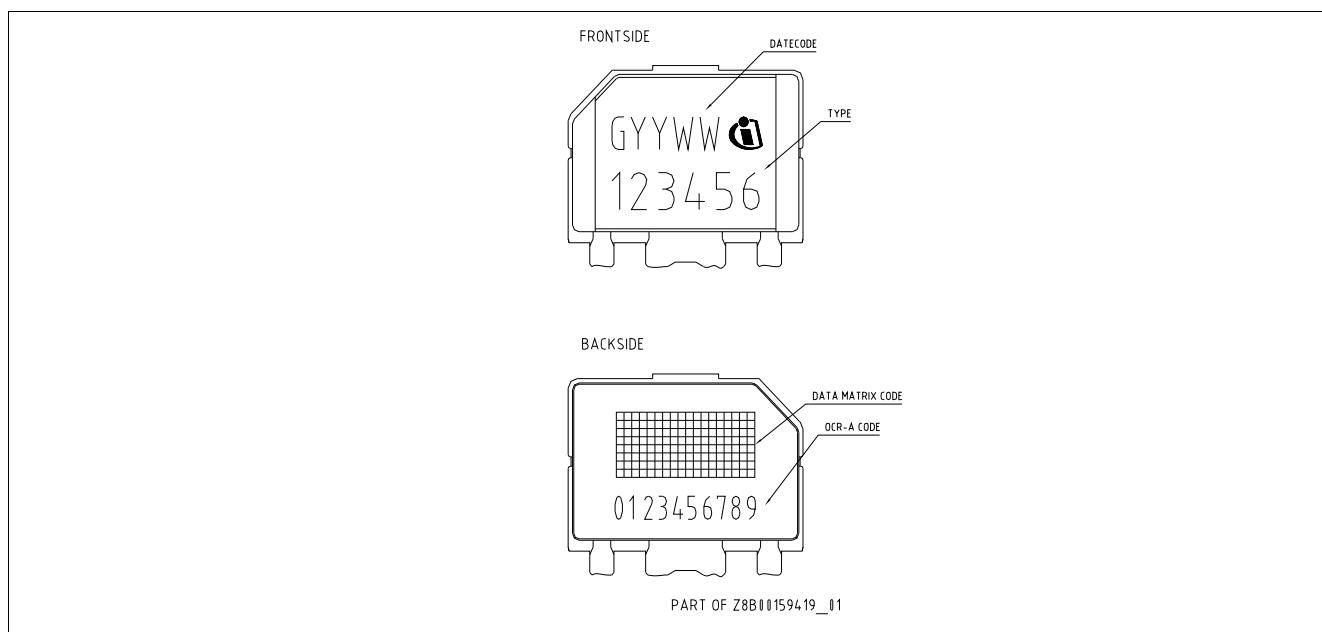

Figure 8 Marking of PG-SSO-3-52 Package

4.4 Pin Configuration and Sensitive Area

Table 5 Pin Description

Pin Number <sup>1)</sup>	Symbol	Function
1	$V_{DD}$	Supply Voltage
2	GND	Ground
3	Q	Open Drain Output

1) Refer to frontside view: leftmost pin corresponding to pin number 1



---

**Revision History**

**5 Revision History**

<b>Version</b>	<b>Date</b>	<b>Changes</b>
1.0	2022-06	First version of released Datasheet
1.1	2022-06	Sudden airgap jump capability added

#### Trademarks of Infineon Technologies AG

$\mu$ HVIC™,  $\mu$ IPM™,  $\mu$ PFC™, AU-ConvertIR™, AURIX™, C166™, CanPAK™, CIPOS™, CIPURSE™, CoolDP™, CoolGaN™, COOLiR™, CoolMOS™, CoolSET™, CoolSiC™, DAVE™, DI-POL™, DirectFET™, DrBlade™, EasyPIM™, EconoBRIDGE™, EconoDUAL™, EconoPACK™, EconoPIM™, EiceDRIVER™, eupec™, FCOS™, GaNpowIR™, HEXFET™, HITFET™, HybridPACK™, iMOTION™, IRAM™, ISOFACE™, IsoPACK™, LEDriviR™, LITIX™, MIPAQ™, ModSTACK™, my-d™, NovalithIC™, OPTIGA™, OptiMOS™, ORIGA™, PowIRaudio™, PowIRstage™, PrimePACK™, PrimeSTACK™, PROFET™, PRO-SIL™, RASIC™, REAL3™, SmartLEWIS™, SOLID FLASH™, SPOC™, StrongIRFET™, SupIRBuck™, TEMPFET™, TRENCHSTOP™, TriCore™, UHVIC™, XHP™, XMC™.

Trademarks updated November 2015

#### Other Trademarks

All referenced product or service names and trademarks are the property of their respective owners.

**Edition 2018-02**

**Published by**

**Infineon Technologies AG**

**81726 Munich, Germany**

**© 2022 Infineon Technologies AG.**

**All Rights Reserved.**

**Do you have a question about any aspect of this document?**

**Email: [erratum@infineon.com](mailto:erratum@infineon.com)**

#### IMPORTANT NOTICE

The information given in this document shall in no event be regarded as a guarantee of conditions or characteristics ("Beschaffheitsgarantie").

With respect to any examples, hints or any typical values stated herein and/or any information regarding the application of the product, Infineon Technologies hereby disclaims any and all warranties and liabilities of any kind, including without limitation warranties of non-infringement of intellectual property rights of any third party.

In addition, any information given in this document is subject to customer's compliance with its obligations stated in this document and any applicable legal requirements, norms and standards concerning customer's products and any use of the product of Infineon Technologies in customer's applications.

The data contained in this document is exclusively intended for technically trained staff. It is the responsibility of customer's technical departments to evaluate the suitability of the product for the intended application and the completeness of the product information given in this document with respect to such application.

For further information on technology, delivery terms and conditions and prices, please contact the nearest Infineon Technologies Office ([www.infineon.com](http://www.infineon.com)).

#### WARNINGS

Due to technical requirements products may contain dangerous substances. For information on the types in question please contact your nearest Infineon Technologies office.

Except as otherwise explicitly approved by Infineon Technologies in a written document signed by authorized representatives of Infineon Technologies, Infineon Technologies' products may not be used in any applications where a failure of the product or any consequences of the use thereof can reasonably be expected to result in personal injury.

## Looking for pricing, stock, or lifecycle information?

Click below to explore more details on WIN SOURCE:

- ⊖ [View TLE4959CHAMA1](#) on WIN SOURCE
- ⊖ [Infineon Technologies](#) Information

## Optimize Your Supply Chain with WIN SOURCE Solutions

- ✓ Global Sourcing Solution
- ✓ Obsolete Management
- ✓ Cost Control Management
- ✓ Shortage Management
- ✓ Alternative Solution
- ✓ Excess Inventory Management