

# TMAG6180-Q1 Automotive High-Precision Analog AMR 360° Angle Sensor

## 1 Features

- AEC-Q100 qualified for automotive applications:
  - Temperature grade 0: –40°C to 150°C
- [Functional Safety-Compliant](#)
  - Developed for functional safety applications
  - Documentation to aid ISO 26262 system design up to ASIL B
- High-accuracy, low angle error AMR sensor:
  - 0.1° (typical)
  - 0.4° (maximum across temperature at 3.3V)
  - 0.56° (maximum across temperature at 5.5V)
- High-speed AMR angle sensor:
  - Ultra low latency < 2μs supports up to 100krpm
- Low angle drift eliminates the need for calibration across temperatures
- Sine and cosine differential ratiometric analog outputs
- Supports differential-ended or single-ended applications
- Wide operating magnetic field range: 20mT to 1T
- Fast start-up time: < 40μs
- Integrated Quadrant Detection using Hall sensors
  - Extends AMR angle range to 360°
  - Can be used for speed and direction
  - Open-drain digital outputs
- Supply voltage range: 2.7V to 5.5V

## 2 Applications

- [Electric Power Steering](#)
- [Steering Angle Sensor](#)
- [BLDC/PMSM Motor Position Sensing](#)
- [E-bikes](#)
- [Wiper modules](#)
- [Actuators](#)
- [Servo drive position sensors](#)
- [Traction Motors](#)

## 3 Description

The TMAG6180-Q1 is a high-precision angle sensor based on Anisotropic Magneto Resistive (AMR) technology. The device features integrated signal conditioning amplifiers and provides differential sine and cosine analog outputs related to the direction of the applied in-plane magnetic field. This device also features two independent Hall sensor outputs at X and Y axes that can be used to extend the angle range of the sensor to 360°.

The TMAG6180-Q1 features a wide operating magnetic field that enables flexible mechanical placements as well as low latency (1.6μs) outputs for high-speed applications like rotor position sensing. The device features ultra-low latency on the sine and cosine outputs to minimize latency related angle errors and is designed for high-speed applications like rotor position sensing up to 100krpm.

The TMAG6180-Q1 offers extensive diagnostics to support stringent functional safety automotive and industrial requirements. The device performs consistently across a wide ambient temperature range of –40°C to +150°C with minimal thermal drift and lifetime errors.

### Package Information

PART NUMBER	PACKAGE <sup>(1)</sup>	PACKAGE SIZE <sup>(2)</sup>
TMAG6180-Q1	DGK (VSSOP, 8)	3mm × 4.9mm

(1) For more information, see [Section 10](#)

(2) The package size (length × width) is a nominal value and includes pins, where applicable.

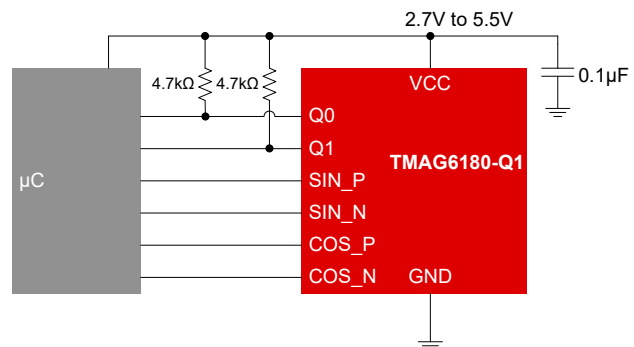

Application Block Diagram



## Table of Contents

<b>1 Features</b> .....	1	6.4 Device Functional Modes.....	21
<b>2 Applications</b> .....	1	<b>7 Application and Implementation</b> .....	22
<b>3 Description</b> .....	1	7.1 Application Information.....	22
<b>4 Pin Configuration and Functions</b> .....	3	7.2 Typical Application.....	24
<b>5 Specifications</b> .....	4	7.3 Power Supply Recommendations.....	29
5.1 Absolute Maximum Ratings.....	4	7.4 Layout.....	29
5.2 ESD Ratings.....	4	<b>8 Device and Documentation Support</b> .....	30
5.3 Recommended Operating Conditions.....	4	8.1 Receiving Notification of Documentation Updates... 30	
5.4 Thermal Information.....	4	8.2 Support Resources.....	30
5.5 Electrical Characteristics.....	5	8.3 Trademarks.....	30
5.6 Magnetic Characteristics.....	6	8.4 Electrostatic Discharge Caution.....	30
5.7 Typical Characteristics.....	7	8.5 Glossary.....	30
<b>6 Detailed Description</b> .....	8	<b>9 Revision History</b> .....	30
6.1 Overview.....	8	<b>10 Mechanical, Packaging, and Orderable Information</b> .....	30
6.2 Functional Block Diagram.....	8		
6.3 Feature Description.....	9		

## 4 Pin Configuration and Functions

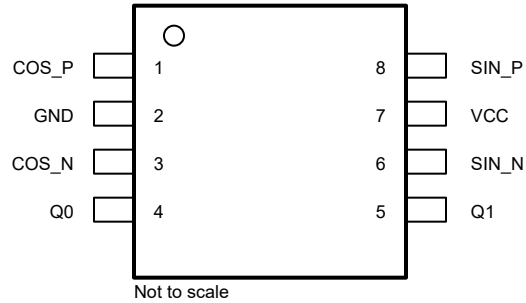

**Figure 4-1. DGK Package 8-Pin VSSOP Top View**

**Table 4-1. Pin Functions**

PIN		TYPE <sup>(1)</sup>	DESCRIPTION
NO.	NAME		
1	COS_P	O	Differential cosine output (positive)
2	GND	G	Ground reference
3	COS_N	O	Differential cosine output (negative)
4	Q0	O	Quadrature 0 digital output (open drain)
5	Q1	O	Quadrature 1 digital output (open drain)
6	SIN_N	O	Differential sine output (negative)
7	VCC	P	Power supply
8	SIN_P	O	Differential sine output (positive)

(1) I = input, O = output, I/O = input and output, G = ground, P = power

## 5 Specifications

### 5.1 Absolute Maximum Ratings

over operating free-air temperature range (unless otherwise noted)<sup>(1)</sup>

		MIN	MAX	UNIT
V <sub>CC</sub>	Main supply voltage	-0.3	7	V
I <sub>OUT</sub>	Output current (SIN_P, SIN_N, COS_P, COS_N, Q1, Q0)	-10	10	mA
V <sub>OUT</sub>	Output voltage (SIN_P, SIN_N, COS_P, COS_N, Q1, Q0)	-0.3	7	V
T <sub>J</sub>	Junction temperature	-40	170	°C
T <sub>stg</sub>	Storage temperature	-65	150	°C

- (1) Operation outside the Absolute Maximum Ratings may cause permanent device damage. Absolute maximum ratings do not imply functional operation of the device at these or any other conditions beyond those listed under Recommended Operating Conditions. If briefly operating outside the Recommended Operating Conditions but within the Absolute Maximum Ratings, the device may not sustain damage, but it may not be fully functional. Operating the device in this manner may affect device reliability, functionality, performance, and shorten the device lifetime.

### 5.2 ESD Ratings

			VALUE	UNIT
V <sub>(ESD)</sub>	Electrostatic discharge	Human body model (HBM), per AEC Q100-002 <sup>(1)</sup> HBM ESD classification level 2	±2000	V
		Charged device model (CDM), per AEC Q100-011	±500	
		CDM ESD classification level C4B	Corner pins (1, 4, 5, and 8)	

- (1) AEC Q100-002 indicates that HBM stressing shall be in accordance with the ANSI/ESDA/JEDEC JS-001 specification.

### 5.3 Recommended Operating Conditions

over operating free-air temperature range (unless otherwise noted)

		MIN	NOM	MAX	UNIT
V <sub>CC</sub>	Main supply voltage	2.7		5.5	V
T <sub>A</sub>	Operating free air temperature	-40		150	C
C <sub>L</sub>	Capacitive load on SIN_P, SIN_N, COS_P, COS_N	0.1		10	nF
I <sub>L</sub>	Current load on SIN_P, SIN_N, COS_P, COS_N	-1		1	mA
B	Magnetic flux density for AMR saturation	20			mT

### 5.4 Thermal Information

THERMAL METRIC <sup>(1)</sup>		TMAG6180-Q1	UNIT
		DGK (VSSOP)	
		8 PINS	
R <sub>θJA</sub>	Junction-to-ambient thermal resistance	166.8	°C/W
R <sub>θJC(top)</sub>	Junction-to-case (top) thermal resistance	57.8	°C/W
R <sub>θJB</sub>	Junction-to-board thermal resistance	88.7	°C/W
Ψ <sub>JT</sub>	Junction-to-top characterization parameter	7.0	°C/W
Ψ <sub>JB</sub>	Junction-to-board characterization parameter	87.1	°C/W

- (1) For more information about traditional and new thermal metrics, see the [Semiconductor and IC Package Thermal Metrics](#) application report.

## 5.5 Electrical Characteristics

over operating free-air temperature range (unless otherwise noted); typical specifications are at  $T_A = 25^\circ\text{C}$

PARAMETER		TEST CONDITIONS	MIN	TYP	MAX	UNIT
<b>AMR Output Parameters</b>						
$V_{out}$	Single-ended output voltage peak to peak	$V_{CC} = 3.3\text{V}$	57	62	67.5	$\%V_{CC}$
$V_{out}$	Single-ended output voltage peak to peak	$V_{CC} = 5.5\text{V}$	55	60	65	$\%V_{CC}$
k	Amplitude asynchronism ratio ( $V_{pk} \cos / V_{pk} \sin$ )	$B = 30\text{mT}, V_{CC} = 3.3\text{V}$	-2.3	0.3	2.3	%
		$B = 30\text{mT}, V_{CC} = 5\text{V}$	-2.4	0.3	2.4	%
$V_{offset\_room}$	Differential offset of SIN/COS outputs at room	$B = 30\text{mT}, T_A = 25^\circ\text{C}, V_{CC} = 3.3\text{V}$	-56		56	mV
		$B = 30\text{mT}, T_A = 25^\circ\text{C}, V_{CC} = 5\text{V}$	-90		90	mV
$V_{offset\_tc}$	Temperature coefficient of differential offset voltage	$B = 30\text{mT}, V_{CC} = 3.3\text{V}$		$\pm 0.1$		$\text{mV}/^\circ\text{C}$
		$B = 30\text{mT}, V_{CC} = 5\text{V}$		$\pm 0.1$		$\text{mV}/^\circ\text{C}$
$V_{CM}$	Common-mode output voltage	$B = 30\text{mT}, V_{CC} = 3.3\text{V}$	48	50	52	$\%V_{CC}$
		$B = 30\text{mT}, V_{CC} = 5\text{V}$	48	50	52	$\%V_{CC}$
$V_{NOISE}$	Output referred noise (differential)	$B = 30\text{mT}, C_{load} = 100\text{pF}$		0.5		$\text{mV}_{rms}$
$R_{out}$	Series output resistance			55		$\Omega$
$t_{agc\_update}$	Update rate of the automatic gain control	After $V_{out}$ reaching 60% of $V_{CC}$		1		s
<b>DC Power</b>						
$V_{CC\_UV}$	VCC undervoltage threshold			2.45	2.65	V
$V_{CC\_OV}$	VCC overvoltage threshold			5.9	6.36	V
$V_{CC\_RAMP}$	Power supply ramp rate for proper device start-up	$V_{CC} = 10\%$ to $90\%$ Specified by design			0.2	ms
$I_{ACT}$	Active mode current from VCC			6.5	10	mA
$t_{on\_startup}$	Power-on time during start-up	To achieve 90% of output voltages after VCC has reached final value ( $C_{LOAD} = 100\text{pF}$ )		38	85	$\mu\text{s}$
<b>Digital I/O</b>						
$V_{OL\_Q}$	Low level output voltage	$I_O = 1\text{mA}$ on Q0, Q1 pins	0		0.4	V
<b>Hall sensor outputs</b>						
tpd	Propagation delay time per channel	Change in $B_{OP}$ or $B_{RP}$ to change in output		10		$\mu\text{s}$

## 5.6 Magnetic Characteristics

over operating free-air temperature range (unless otherwise noted); typical specifications are at  $T_A = 25^\circ\text{C}$

PARAMETER		TEST CONDITIONS	MIN	TYP	MAX	UNIT
<b>Angular Performance</b>						
ANG <sub>ERR_DYN_SE</sub>	Angular error linearity across temperature on continuous calibration (gain / offset) (single ended)	B = 30mT, V <sub>CC</sub> = 3.3V, Magnetic field Rotation Speed = 1000rpm		0.1	0.35	deg
		B = 30mT, V <sub>CC</sub> = 5V, Magnetic field Rotation Speed = 1000rpm		0.1	0.56	deg
ANG <sub>ERR_DYN_DE</sub>	Angular error linearity across temperature on continuous calibration (gain / offset) (differential ended)	B = 30mT, V <sub>CC</sub> = 3.3V, Magnetic field Rotation Speed = 1000rpm		0.1	0.4	deg
		B = 30mT, V <sub>CC</sub> = 5V, Magnetic field Rotation Speed = 1000rpm		0.1	0.56	deg
ANG <sub>ERR_RTCAL_SE</sub>	Angular error linearity across temperature after room temperature calibration (of offset / gain mismatch) (single ended)	B = 30mT, V <sub>CC</sub> = 3.3V, Ideal magnet alignment		0.1	1.1	deg
		B = 30mT, V <sub>CC</sub> = 5V, Ideal magnet alignment		0.1	1.1	deg
ANG <sub>ERR_RTCAL_DE</sub>	Angular error linearity across temperature after room temperature calibration (of offset / gain mismatch) (differential ended)	B = 30mT, V <sub>CC</sub> = 3.3V, Ideal magnet alignment		0.2	1.0	deg
		B = 30mT, V <sub>CC</sub> = 5V, Ideal magnet alignment		0.1	0.95	deg
ANG <sub>ERR_NOCAL_SE</sub>	Angular error linearity across temperature with no calibration of gain / offset (single ended)	B = 30mT, V <sub>CC</sub> = 3.3V, Ideal magnet alignment		0.5	1.52	deg
		B = 30mT, V <sub>CC</sub> = 5V, Ideal magnet alignment		0.5	1.26	deg
ANG <sub>ERR_NOCAL_DE</sub>	Angular error linearity across temperature with no calibration of gain / offset (differential ended)	B = 30mT, V <sub>CC</sub> = 3.3V, Ideal magnet alignment		0.4	1.1	deg
		B = 30mT, V <sub>CC</sub> = 5V, Ideal magnet alignment		0.4	1.0	deg
ANG <sub>LT_DRIFT</sub>	Angle error lifetime drift	B = 30mT		0.05	±0.75	deg
ANG <sub>HYST</sub>	Angle hysteresis error	B = 30mT		0.01	0.06	deg
ANG <sub>OE_ERR</sub>	Orthogonality error	B = 30mT		0.01	0.051	deg
ANG <sub>NOISE</sub>	Angular RMS (1-sigma) noise in degrees	B = 30mT, C <sub>load</sub> = 100pF		0.01	0.06	deg
t <sub>del_amr</sub>	Propagation Delay time	C <sub>load</sub> = 100pF		1.6		µs
BW <sub>3dB_amr</sub>	3dB Bandwidth	C <sub>load</sub> = 100pF		100		KHz
φ <sub>err</sub>	Phase error	Magnetic Field Rotation Speed = 10000rpm, C <sub>load</sub> = 100pF		0.15		deg
<b>Hall sensor characteristics</b>						
B <sub>OP(X)</sub> , B <sub>OP(Y)</sub>	Magnetic field operating point			3		mT
B <sub>RP(X)</sub> , B <sub>RP(Y)</sub>	Magnetic field release point			-3		mT
B <sub>OP</sub> - B <sub>RP</sub>	Magnetic hysteresis			3.5	6	mT
B <sub>SYM_OP</sub>	Operating point symmetry	Bop(x) – Bop(y)		±0.5		mT
B <sub>SYM_RP</sub>	Release point symmetry	Brp(x) – Brp(y)		±0.5		mT
B <sub>SYM_RP</sub>	Release point symmetry	Brp(x) – Brp(y)		0		mT
t <sub>PD_HALL</sub>	Propagation delay time per channel	Change in B <sub>OP</sub> or B <sub>RP</sub> to change in output		10		µs

### 5.7 Typical Characteristics

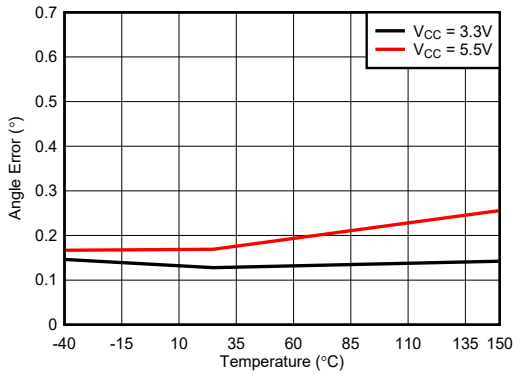

**Figure 5-1. Absolute Angle Error. Differential with Dynamic Calibration**

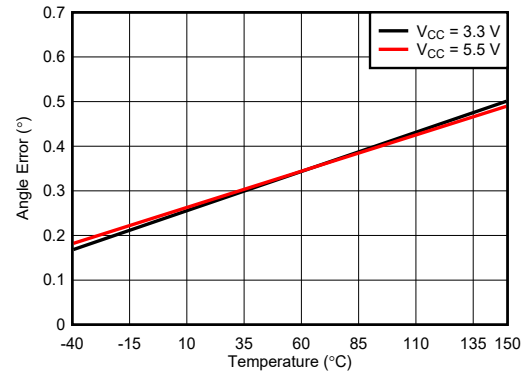

**Figure 5-2. Absolute Angle Error. Differential with Room Temperature Calibration**

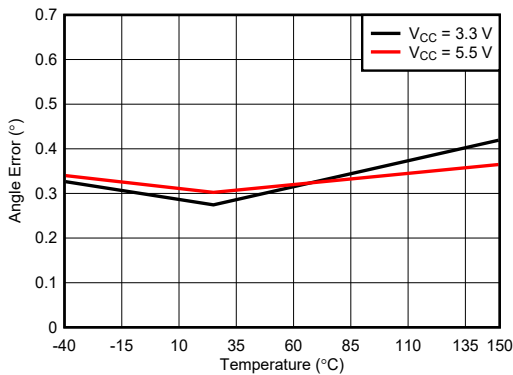

**Figure 5-3. Absolute Angle Error. Differential with No Calibration**

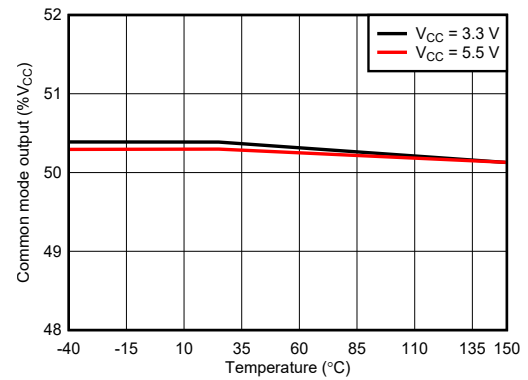

**Figure 5-4. AMR Common-Mode Output Voltage**

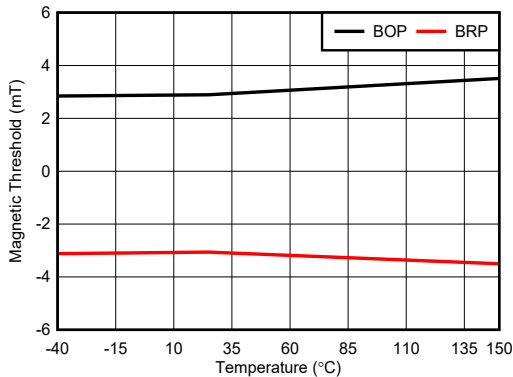

**Figure 5-5. Hall Sensor BOP and BRP Typical Threshold**

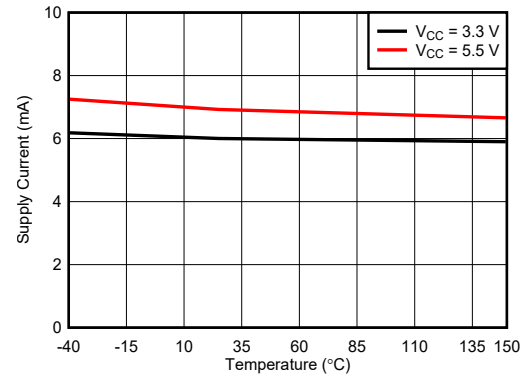

**Figure 5-6. Active Mode Current**

## 6 Detailed Description

### 6.1 Overview

The TMAG6180-Q1 is a high-precision angle sensor based on the AMR sensor technology vertically integrated on top of the integrated amplifiers on silicon. The differential output sine and cosine signals from the AMR sensor are proportional to the angle of the applied magnetic field. The sine and cosine signals are internally signal conditioned, temperature compensated, and driven by differential output amplifiers with the ability to drive large capacitive loads. The output voltages of the AMR sensor are ratiometric to the supply voltage, therefore the external ADC can use the supply voltage as a reference.

TMAG6180-Q1 integrates X and Y Hall sensors to provide quadrature outputs on pins Q0 and Q1, respectively. The Hall effect sensors are chopper stabilized, signal conditioned, and multiplexed to provide two digital latched outputs. These outputs can be used to extend the angle sensing range of the AMR sensor from 180 degrees to 360 degrees.

The TMAG6180-Q1 contains the following functional and building blocks:

- The Power Management and Oscillators block contains internal regulators, biasing circuitry, a low-frequency, wake-up oscillator and a high-frequency, wake-up oscillator, overvoltage detection circuitry, and undervoltage detection circuitry
- The AMR sensor contains two Wheatstone bridges made of magnetic resistive sensors, each sensing one of the components of the applied magnetic field, the sine and the cosine components.
- The AMR sensing path contains the signal conditioning amplifiers, offset compensation, automatic gain control circuitry and the output drivers.
- The Quadrature Detection Path contains the X and Y Hall sensors, related biasing circuitry, signal conditioning, logic comparators and digital logic to drive the Q1 and Q0 outputs
- The Internal memory block supports the factory-programmed values
- The diagnostic blocks support background diagnostic checks of the internal circuitry

### 6.2 Functional Block Diagram

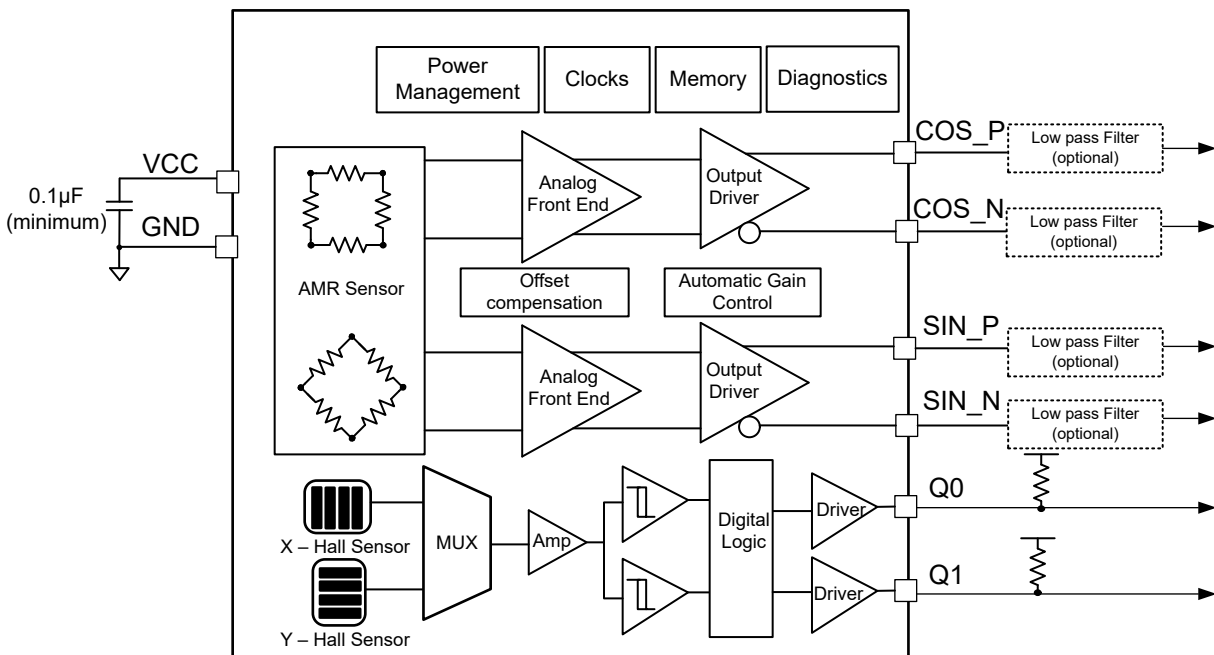

## 6.3 Feature Description

### 6.3.1 Magnetic Flux Direction

The TMAG6180-Q1 is sensitive to the magnetic field component in X and Y directions. The X and Y fields are in-plane with the package. The device generates sine and cosine outputs from the AMR based on the reference position ( $0^\circ$ ). See [Direction of Sensitivity](#).

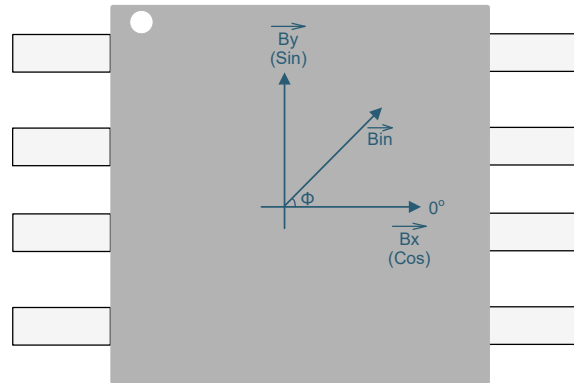

**Figure 6-1. Direction of Sensitivity**

### 6.3.2 Sensors Location and Placement Tolerances

[Location of AMR Sensor and Hall Elements](#) shows the location of the AMR sensor and X, Y Hall elements, along with the placement tolerances inside the TMAG6180-Q1.

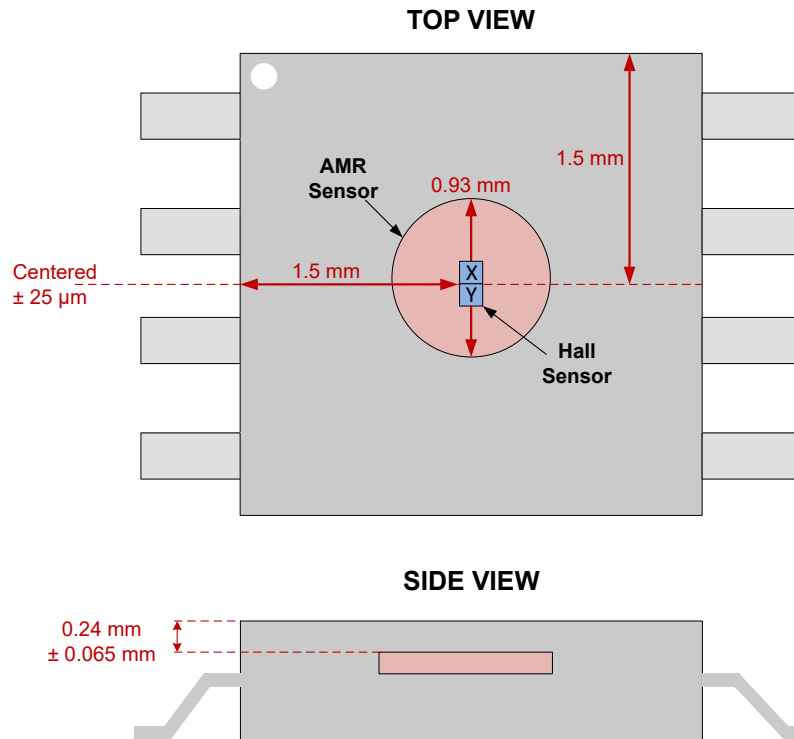

**Figure 6-2. Location of AMR Sensor and Hall Elements**

The center of the AMR and Hall sensors lie in the center of the package. [Die Rotation Tolerances in the Package](#) shows the tolerances of the die rotation within the package. This causes a reference angle error ( $\Phi$ ) of  $\pm 3^\circ$ .

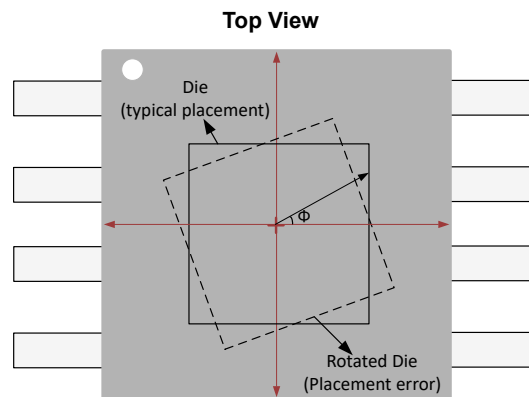

**Figure 6-3. Die Rotation Tolerances in the Package**

### 6.3.3 Magnetic Response

The AMR sensor has two components that are sensitive to the in-plane magnetic field X and Y axes parallel to the chip surface. Section 6.3.3 shows the AMR sensor with the differential sine and cosine outputs SIN\_P, SIN\_N, COS\_P and COS\_N. The outputs have an electrical range of 180 degrees. If the mechanical angle between the sensor reference and the direction of the magnetic field is  $\theta$ , then the AMR outputs correspond to cosine  $2\theta$  and sine  $2\theta$  respectively. For every  $360^\circ$  rotation of the external magnetic field, the AMR outputs provide two periods, at  $180^\circ$  sensing range for each period. Hence, for a dipole magnet rotating at speed of  $f$ , the electrical output from the AMR sensor outputs can be at twice the frequency at  $2f$ . Use Equation 1 to calculate the angle of the magnetic field is calculated using an arctangent2 function.

$$\theta = \frac{\arctan2\left(\frac{V_{\sin}}{V_{\cos}}\right)}{2} \tag{1}$$

where

- $V_{\sin}$  is the differential sine output
- $V_{\cos}$  is the differential cosine output

The AMR sensor is sensitive only to the direction of the magnetic field and has a wide operating magnetic field range. The voltage levels of the AMR outputs are independent of the absolute flux density as long as the magnetic flux density is above the minimum recommended operating fields.

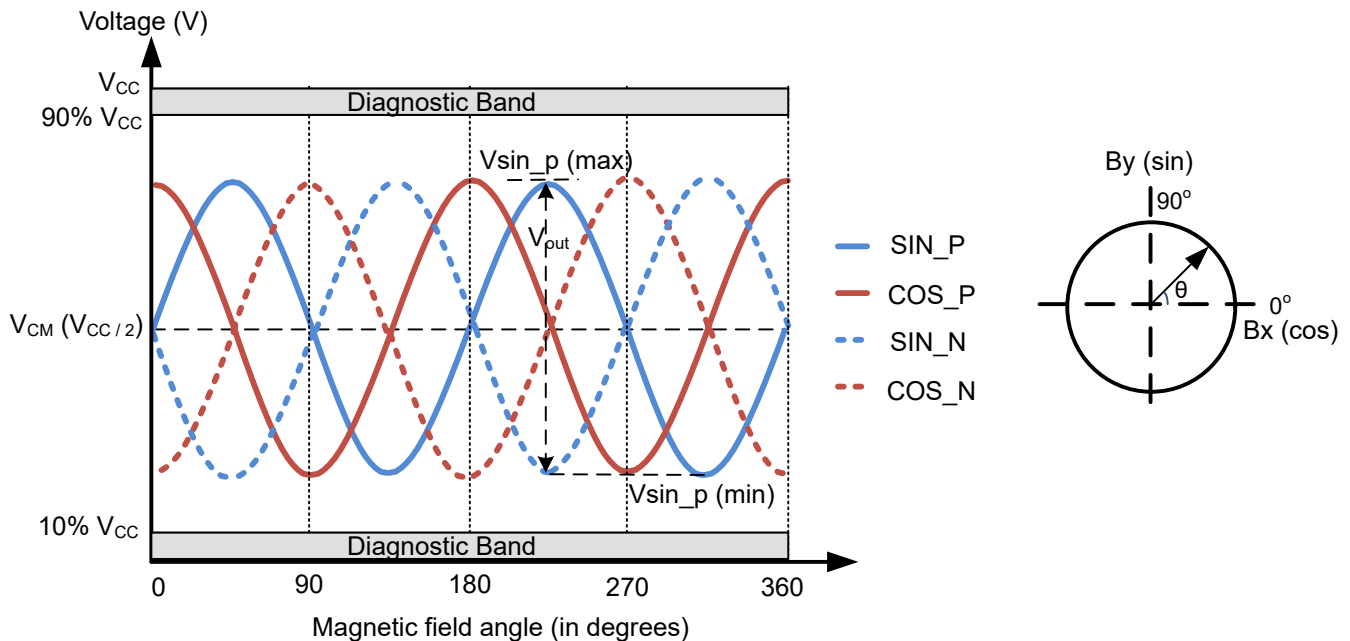

**Figure 6-4. AMR Sensor Outputs Magnetic Response**

The two integrated Hall sensors X and Y that are sensitive to the in-plane X and Y axes similar to the AMR sensor. Figure 6-5 shows both the Hall outputs reacting to the input field by going low when the field is higher than operating point ( $B_{OP}$ ) and going high when the field is lower than returning point ( $B_{RP}$ ).

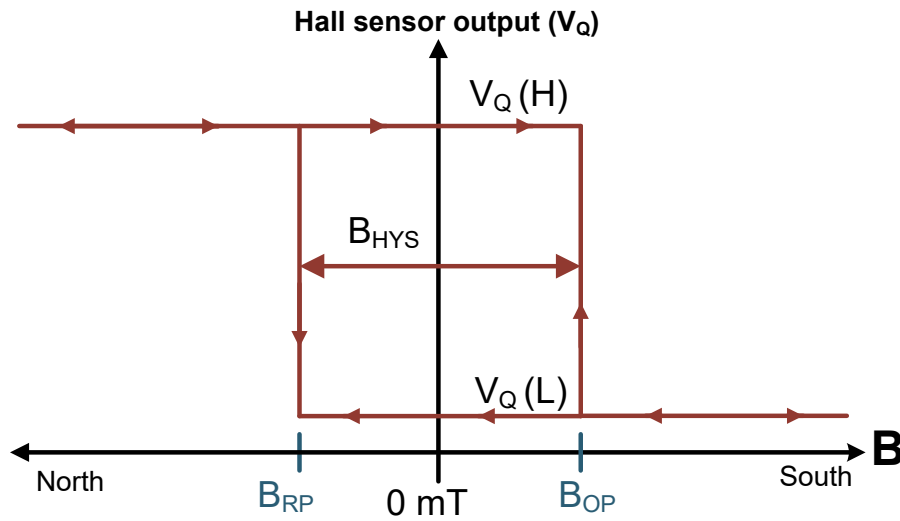
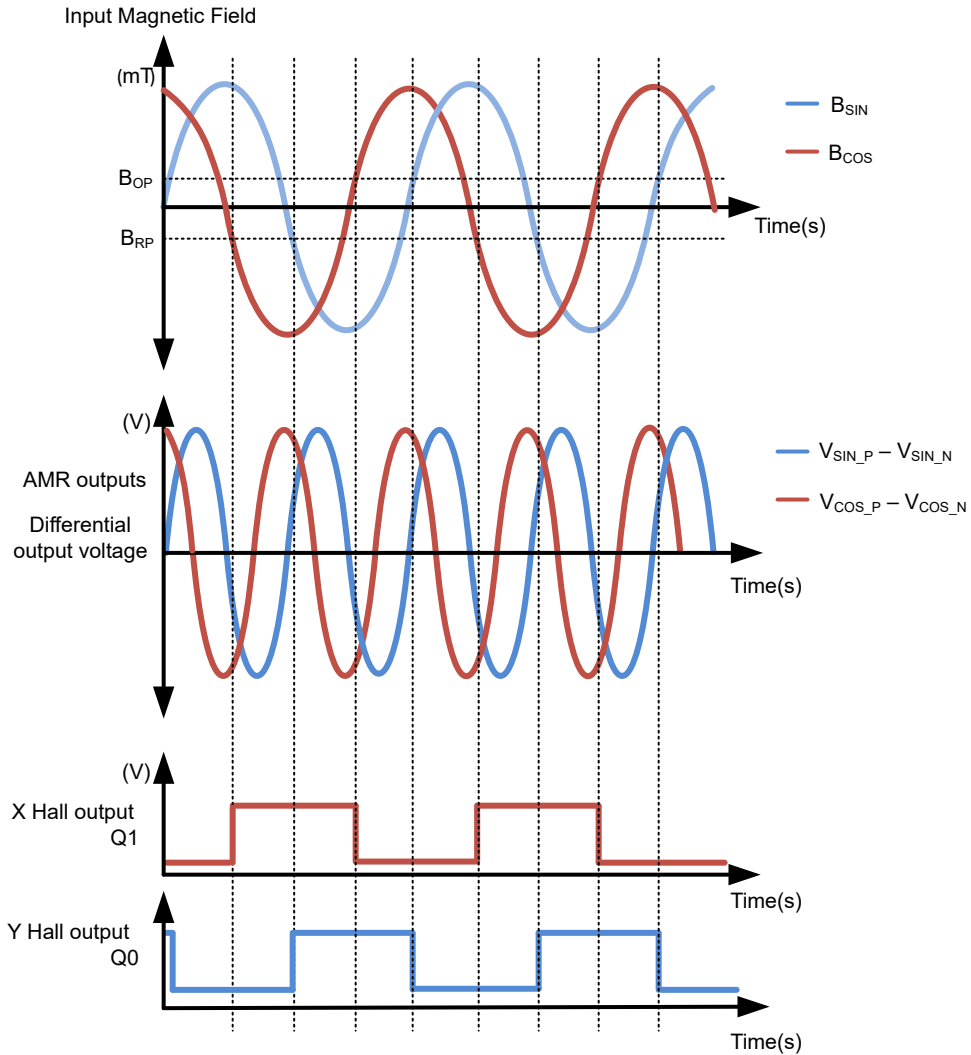

Figure 6-5. Hall Sensor Magnetic Response

For a rotating input magnetic field, with the X and Y components of  $B_{SIN}$  and  $B_{COS}$  respectively, [Figure 6-6](#) shows the response of the AMR and Hall sensors. The integrated X and Y Hall sensors provide digital outputs (Q0 and Q1, respectively). See the [Functional Block Diagram](#). The Hall sensors have a  $360^\circ$  compared to the  $180^\circ$  angle range of the AMR sensors. By utilizing the digital outputs of the Hall sensors, the angle range of the AMR sensor can be extended to  $360^\circ$ .

**Figure 6-6. Magnetic Response of AMR and Hall sensors**



### 6.3.4 Parameters Definition

#### 6.3.4.1 AMR Output Parameters

The single-ended output signals SIN\_P, SIN\_N, COS\_P and COS\_N are shown in [Figure 6-4](#). These signals are ratiometric to the supply voltage ( $V_{CC}$ ). The common-mode voltage ( $V_{CM}$ ) of the individual signals is half of the supply voltage ( $V_{CC}/2$ ). For single-ended signals,  $V_{OUT}$  is defined as the difference between the maximum and minimum output voltage for a rotating magnetic field. Use [Equation 2](#) to calculate  $V_{OUT\_SIN\_P}$ .

$$V_{OUT\_SIN\_P} = V_{SIN\_P(max)} - V_{SIN\_P(min)} \quad (2)$$

where

- $V_{SIN\_P(min)}$  is the minimum output voltage across the full magnetic angle range
- $V_{SIN\_P(max)}$  is the maximum output voltage across the full magnetic angle range

Typically,  $V_{OUT}$  is around 60% of the supply voltage ( $V_{CC}$ ). The diagnostic band shown in [AMR Sensor Outputs Magnetic Response](#) indicates that the output signals are outside normal operating range and indicates a presence of fault.

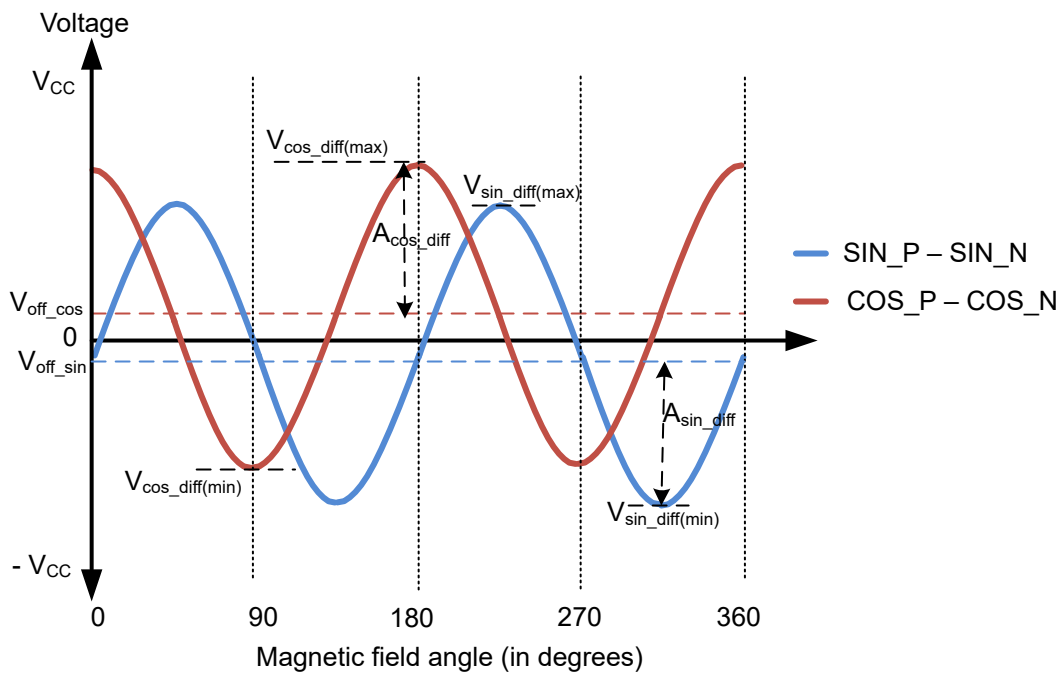

**Figure 6-7. AMR Differential Ended Output Signals**

The differential sine and cosine output signals shown in [Figure 6-7](#) are generated from the corresponding sine and cosine single-ended outputs. Use [Equation 3](#) and [Equation 4](#) to calculate the differential voltages.

$$V_{sin\_diff} = V_{SIN\_P} - V_{SIN\_N} \quad (3)$$

$$V_{cos\_diff} = V_{COS\_P} - V_{COS\_N} \quad (4)$$

The offset of the differential signals is the average of the maximum and minimum voltages of the sine or cosine signals. Use [Equation 5](#) and [Equation 6](#) to calculate the offsets for the sine and cosine signals.

$$V_{offset\_sin} = \frac{V_{sin\_diff(max)} + V_{sin\_diff(min)}}{2} \quad (5)$$

$$V_{\text{offset\_cos}} = \frac{V_{\text{cos\_diff(max)}} + V_{\text{cos\_diff(min)}}}{2} \quad (6)$$

For single-ended signals, the offset is the common-mode voltage ( $V_{\text{CM}}$ ).

Use [Equation 7](#) to calculate the differential offset for sine and cosine channels at any given temperature,  $T_A$ .

$$V_{\text{offset}} = V_{\text{offset\_room}} \times (1 + V_{\text{offset\_TC}} \times (T_A - 25^{\circ}\text{C})) \quad (7)$$

where

- $V_{\text{Offset\_TC}}$  is the temperature drift coefficient of the offset
- $V_{\text{Offset\_room}}$  is the room temperature offset

Use [Equation 8](#) and [Equation 9](#) to calculate the amplitudes of the differential signals.

$$A_{\text{sin\_diff}} = \frac{V_{\text{sin\_diff(max)}} - V_{\text{sin\_diff(min)}}}{2} \quad (8)$$

$$A_{\text{cos\_diff}} = \frac{V_{\text{cos\_diff(max)}} - V_{\text{cos\_diff(min)}}}{2} \quad (9)$$

Use [Equation 10](#) to calculate the amplitude for single-ended signals.

$$A_{\text{sin\_p}} = \frac{V_{\text{sin\_p(max)}} - V_{\text{sin\_p(min)}}}{2} \quad (10)$$

Amplitude asynchronism refers to the amplitude mismatch error between sine and cosine channels. Use [Equation 11](#) to calculate the amplitude mismatch error.

$$k = 1 - \left( \frac{A_{\text{cos\_diff}}}{A_{\text{sin\_diff}}} \right) \quad (11)$$

The sine and cosine output signals are typically out-of-phase by 90 degrees. However, the sine and cosine outputs from the sensor can be different than the ideal 90 degrees if an internal phase error occurs owing to sensor and other on chip circuitry non-idealities. This error is referred to as the orthogonality error. This error is defined as the angle error between the zero crossing of the cosine output and maximum value of the sine outputs.

The hysteresis error ( $\text{ANG}_{\text{hyst}}$ ) refers to the largest angle error difference between a clockwise rotation and a counter-clockwise rotation.

For the AMR sensor, the orthogonality error and the hysteresis errors are negligible.

### 6.3.4.2 Transient Parameters

Propagation delay ( $t_{del\_amr}$ ) is defined as the time taken for signal to propagate from magnetic input change to the sine and cosine AMR outputs. The bandwidth limitation of the internal signal conditioning amplifiers causes a phase shift on the applied magnetic field. The propagation delay increases based on the speed of the rotating field and is specified at the maximum speed of the recommended magnetic field. Figure 6-8 shows an input rotating magnetic field and the response of the AMR outputs. The propagation delay in the signal path leads to a phase error.

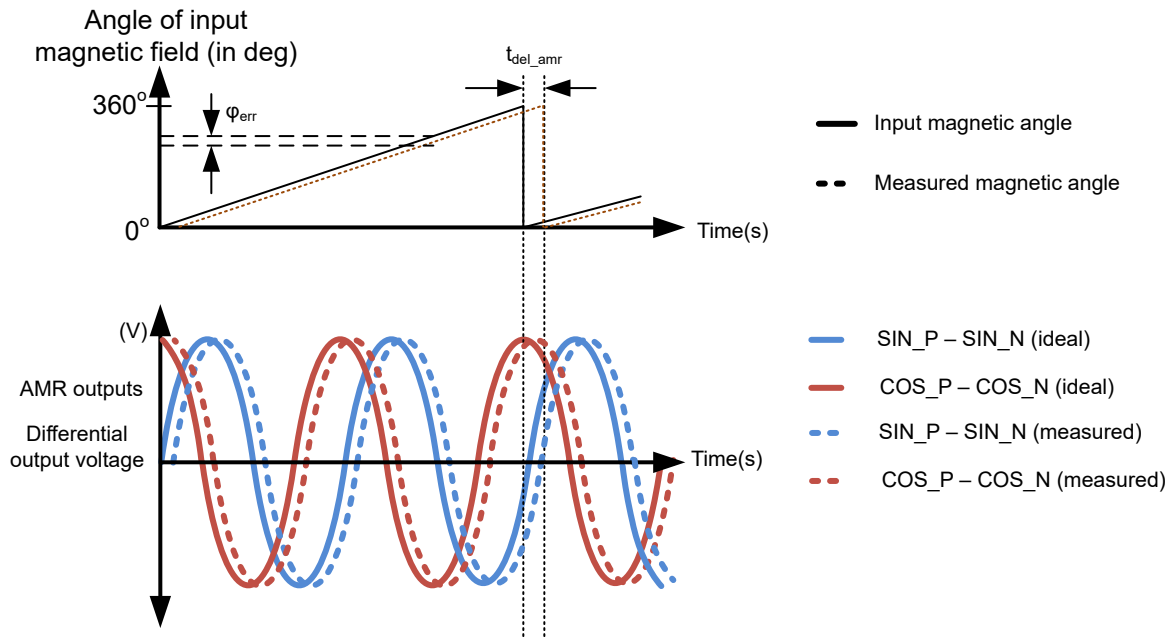
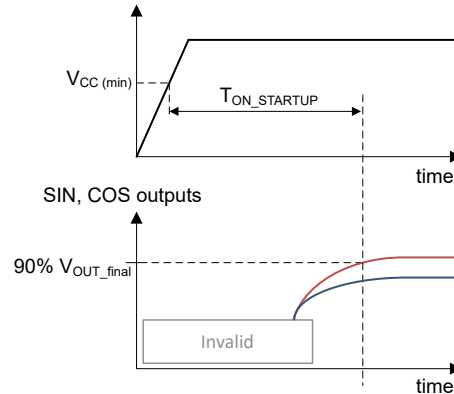

**Figure 6-8. AMR Output Propagation Delay and Phase Error**

The phase error ( $\phi_{err}$ ) refers to the angle error between the input magnetic field and output of the sensor. This error increases with the speed of the rotating magnetic field and the propagation delay of the AMR sensor. Typically, this error can be compensated to the first order if the speed of the rotating magnetic field is known.

### 6.3.4.2.1 Power-On Time

The power-on time during start-up ( $T_{on\_startup}$ ) is defined as the time it takes for the AMR outputs to reach to 90% of their final value (under a constant magnetic field) after the  $V_{CC}$  reaches  $V_{CC(min)}$ . Figure 6-9 shows the power-on time of the device during a  $V_{CC}$  ramp.



**Figure 6-9. Power-On Time During Start-Up**

### 6.3.4.3 Angle Accuracy Parameters

The overall angle error represents the relative angular error. Section 6.3.4.3 shows the deviation from the reference line after zero angle definition..

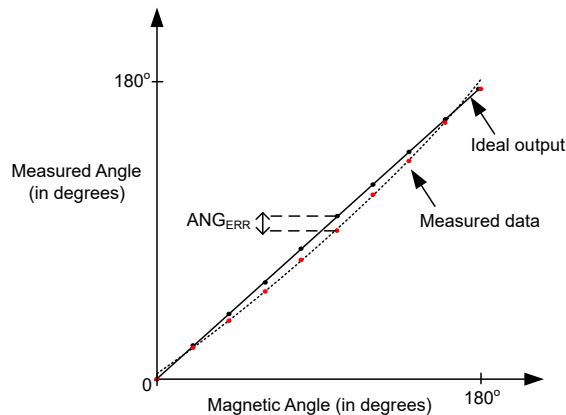

**Figure 6-10. Angle Error**

The uncalibrated angular error ( $ANG_{ERR\_NOCAL\_DE}$ ) is defined as the maximum deviation from an ideal angle without any offset and amplitude mismatch calibration for the VSIN and VCOS differential signals. For single-ended signals, the uncalibrated angular error is denoted by  $ANG_{ERR\_NOCAL\_SE}$ .

The single point calibration angular error ( $ANG_{ERR\_RTCAL\_DE}$ ) is defined as the maximum deviation from an ideal angle after the offset calibration is applied to the VSIN and VCOS differential signals at room temperature (25°C). For single-ended signals, the room-temperature calibrated angular error is denoted by  $ANG_{ERR\_RTCAL\_SE}$ .

The dynamic angular error ( $ANG_{ERR\_DYN}$ ) is defined as the maximum deviation from an ideal angle with the continuous offset and gain calibration applied to the VSIN and VCOS differential signals. The error is measured at 1krpm and includes the phase error owing to the propagation delay of the AMR outputs.

#### 6.3.4.4 Hall Sensor Parameters

The Hall sensors X and Y have factory-calibrated operating ( $B_{OP}$ ) and release points ( $B_{RP}$ ). The operating and release points shown in [Figure 6-4](#) give the magnetic hysteresis for each Hall sensor.

Use [Equation 12](#) and [Equation 13](#) to calculate the symmetry point for each axis.

$$B_{SYM(X)} = B_{OP(X)} + B_{RP(X)} \quad (12)$$

where

- $B_{OP(X)}$  and  $B_{RP(X)}$  represent the operating and release points for X Hall sensor

$$B_{SYM(Y)} = B_{OP(Y)} + B_{RP(Y)} \quad (13)$$

where

- $B_{OP(Y)}$  and  $B_{RP(Y)}$  represent the operating and release points for Y Hall sensor

Use [Equation 14](#) to calculate the operating point symmetry.

$$B_{SYM\_OP} = B_{OP(X)} - B_{OP(Y)} \quad (14)$$

Use [Equation 15](#) to calculate the release point symmetry.

$$B_{SYM\_RP} = B_{RP(X)} - B_{RP(Y)} \quad (15)$$

### 6.3.5 Automatic Gain Control (AGC)

The TMAG6180-Q1 features an automatic gain control circuitry to reduce the drift of the AMR sensor outputs across temperature. The device changes the gain of the output drivers to keep the final output within an appropriate voltage range on SIN\_P, SIN\_N, COS\_P and COS\_N. The AGC block uses the square root of the sum of the squared amplitudes of the two channels to sense amplitude of output signals and set gain selection. The AGC block sets the gain for sine and cosine channels, meaning that the peak-to-peak amplitude of single-ended voltages,  $V_{OUT}$  is within the range listed in [Specifications](#). The AGC block changes the gain of both the sine and cosine channels simultaneously.

If the outputs are out of the normal operating range, the AGC block changes the gain of the sine and cosine channels by a step size of  $\pm 1\% V_{CC}$  at an interval of  $t_{agc\_update}$ , typically around 1 second, as defined in [Specifications](#). [Figure 6-11](#) shows the differential AMR outputs for a continuously rotating input field. The shaded area represents the *No AGC Control* band that represents  $\pm 5\%$  of  $V_{CC}$  and is centered at  $60\%$  of  $V_{CC}$ . Notice that the AGC loop reduces the gain and updates the amplitude at a step size of  $1\% V_{CC}$  as the sine and cosine signals drift outside of the shaded region. If the outputs remain within the shaded region, then no action is taken by the AGC control loop.

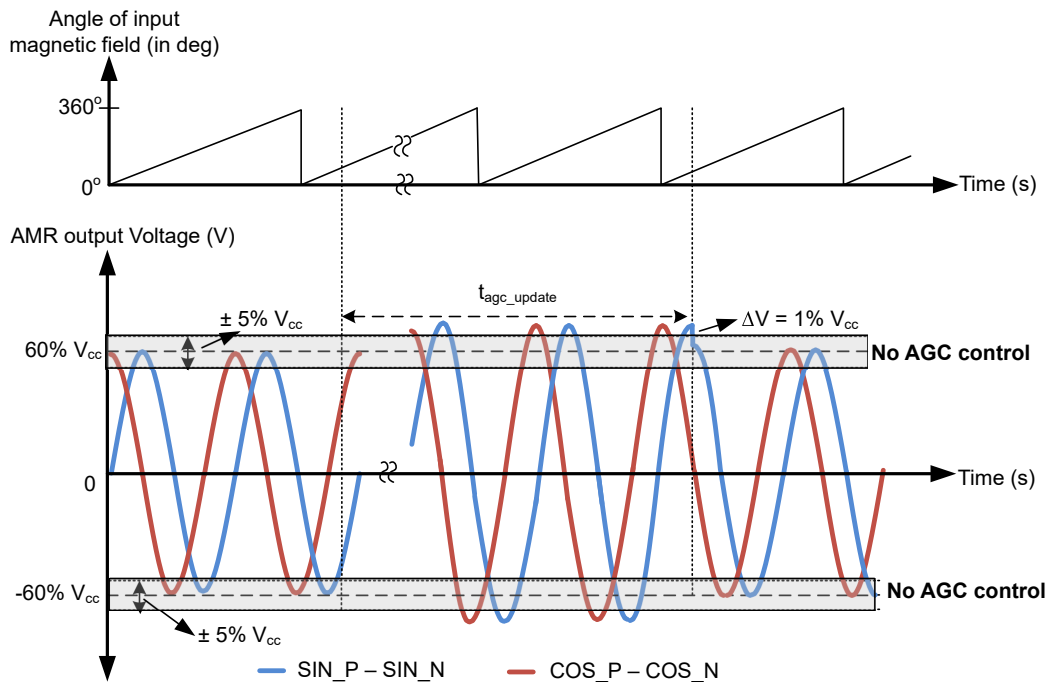

Figure 6-11. Timing Diagram Showing the Operation of Automatic Gain Control

### 6.3.6 Safety and Diagnostics

The TMAG6180-Q1 supports several device and system level diagnostics features to detect, monitor, and report failures during the device operation.

In the event of a failure, the TMAG6180-Q1 is placed in a FAULT state, where the outputs from the AMR sensors are placed in a high-impedance state. As shown in the [Application and Implementation](#) section, users can add pullup or pulldown resistors on SIN\_P, SIN\_N, COS\_P, COS\_N pins at the termination site (that is the microcontroller). The resistors are generally pulled up to supply voltage or pulled down to ground such that the ADC code on MCU is out of expected range. This state signal faults to the microcontroller.

In the fault state, the digital outputs Q0 and Q1 are not driven internally by the device.

The TMAG6180-Q1 performs the following device and system level checks:

#### 6.3.6.1 Device Level Checks

- AMR signal path checks
  - AMR sensor bias check
  - AMR output signals common-mode check
  - Automatic gain control loop check
- Hall sensor signal path checks
  - Hall sensor bias and resistance check
  - Hall sensor comparator check
- Power management and supporting circuitry checks
  - Internal LDO undervoltage check
  - Internal clocks integrity check
- Internal memory integrity check (or a cyclic redundancy check–CRC)

#### 6.3.6.2 System Level Checks

- $V_{CC}$  undervoltage and overvoltage check
- Pin level opens and short checks

## 6.4 Device Functional Modes

### 6.4.1 Operating Modes

The TMAG6180-Q1 has primarily one mode of operation when all the conditions in the [Recommended Operating Conditions](#) are met. When the part detects an internal fault, the device switches into a fault mode (safe state). [Figure 6-12](#) shows the state transition for TMAG6180-Q1.

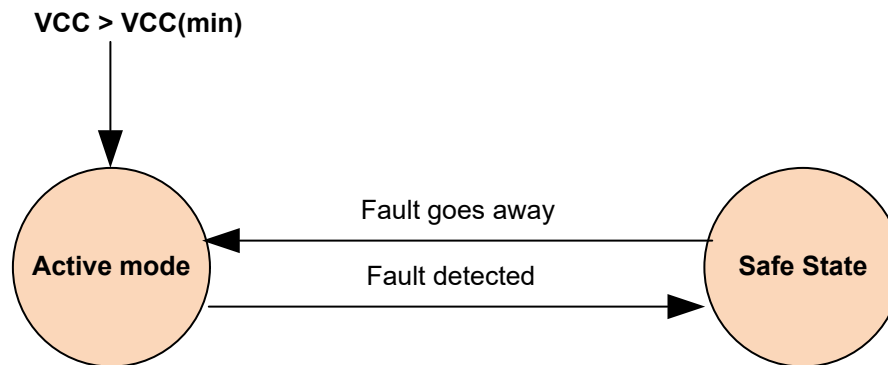

**Figure 6-12. TMAG6180-Q1 State Transition Diagram**

#### 6.4.1.1 Active Mode

The device starts powering up after the  $V_{CC}$  supply crosses the minimum threshold as specified in the [Recommended Operating Conditions](#) table. The TMAG6180-Q1 enters the active mode, in which the SIN\_P, SIN\_N, COS\_P and COS\_N outputs actively provide the angle of the applied magnetic field. The average current consumption during the active conversion is  $I_{ACT}$ .

#### 6.4.1.2 Fault Mode

The TMAG6180-Q1 supports extensive fault diagnostics as detailed in the [Diagnostics](#) section. When a fault is detected, the part enters the fault mode. In this mode, the AMR outputs and the Q0 and Q1 Hall outputs are placed in a high-impedance state.

## 7 Application and Implementation

---

### Note

Information in the following applications sections is not part of the TI component specification, and TI does not warrant its accuracy or completeness. TI's customers are responsible for determining suitability of components for their purposes, as well as validating and testing their design implementation to confirm system functionality.

---

### 7.1 Application Information

#### 7.1.1 Power Supply as the Reference for External ADC

The AMR output signals of the TMAG6180-Q1 are ratiometric to the supply voltage,  $V_{CC}$ . This enables the external ADC to use the TMAG6180-Q1 supply voltage as a reference and eliminate the errors which can arise if a separate reference voltage is used. This also enables the optimization of the external ADC input range. TI therefore recommends to use the supply voltage ( $V_{CC}$ ) as the reference for the external ADCs. TI also recommends using a 0.1 $\mu$ F bypass capacitor to minimize the noise on the power supply.

#### 7.1.2 AMR Output Dependence on Airgap Distance

The AMR sensor is only sensitive to the direction of the applied magnetic field along the X-Y plane parallel to the chip surface. The applied magnetic field from a rotating magnet can vary based on the airgap distance between the TMAG6180-Q1 and the magnet.

As long the absolute magnetic field is above the minimum field listed in [Recommended Operating Conditions](#), the angle accuracy from the AMR outputs are independent of the value of the applied magnetic field.

### 7.1.3 Calibration of Sensor Errors

The TMAG6180-Q1 is factory-calibrated for best angular accuracy. Some of the electrical errors from the sensor that impact the angle accuracy can be calibrated out for achieving the best performance. Figure 7-1 shows the impact of the different sensor error parameters such as offset, amplitude mismatch and orthogonality error on the angle accuracy.

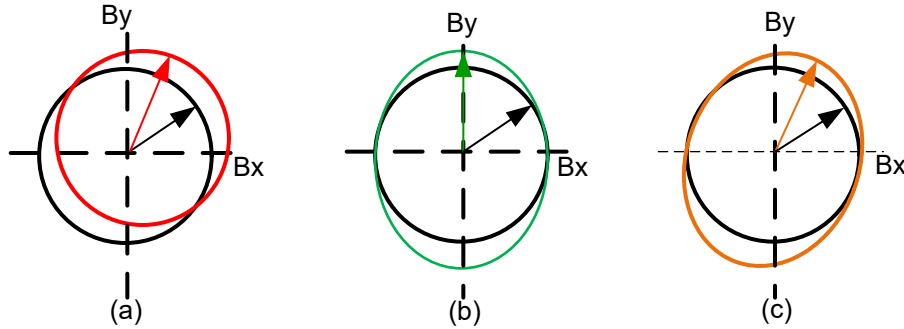

**Figure 7-1. Angle Accuracy Impact Owing to Sensor Electrical Errors (a) Offset Error (b) Amplitude Mismatch Error (c) Orthogonality Error**

Based on the parameters defined in [AMR Output Parameters](#), use [Equation 16](#) to calculate the angle from the AMR sensors.

$$\theta = \frac{\arctan2\left(\frac{A_{\sin} \sin(2\theta) + V_{\text{offset\_sin}}}{A_{\cos} \cos(2\theta) + V_{\text{offset\_cos}}}\right)}{2} \quad (16)$$

where

- $V_{\text{offset\_sin}}$  and  $V_{\text{offset\_cos}}$  are the differential offsets of the sine and cosine outputs
- $A_{\sin}$  and  $A_{\cos}$  are the differential amplitude of the sine and cosine outputs

The impact of the angle accuracy owing to the orthogonality error and the hysteresis errors is negligible for the TMAG6180-Q1 and can be ignored.

To calibrate the offset and amplitude mismatch errors, the magnetic field rotates over the entire range and the sine and cosine outputs are sampled continuously to obtain the minimum and maximum values of the outputs.

Users can calculate the average of the minimum and maximum values of the respective outputs across the full angle range to find the offset error of the sine and cosine outputs. Use [Equation 17](#) and [Equation 18](#) to calculate the offset correction parameters for sine and cosine.

$$V_{\text{os\_sin\_cal}} = \frac{V_{\sin(\text{max})} + V_{\sin(\text{min})}}{2} \quad (17)$$

$$V_{\text{os\_cos\_cal}} = \frac{V_{\cos(\text{max})} + V_{\cos(\text{min})}}{2} \quad (18)$$

Users can calculate the difference of the minimum and maximum values of the respective outputs across the full angle range to find the amplitude of the sine and cosine outputs. Use [Equation 19](#) to calculate the amplitude correction parameters for sine and cosine.

$$A_{\text{corr}} = 1 - \frac{V_{\sin(\text{max})} - V_{\sin(\text{min})}}{V_{\cos(\text{max})} - V_{\cos(\text{min})}} \quad (19)$$

## 7.2 Typical Application

The TMAG6180-Q1 AMR angle sensor can be used either in single-ended output mode or differential output mode. The TMAG6180-Q1 has the drive capability to either drive differential or single-ended SAR or Sigma Delta ADCs. Typically, an external microcontroller processes the AMR output signals to extract the angular position.

The differential-ended output mode is helpful to eliminate any common mode disturbances in the system. Figure 7-2 shows a typical application circuit where the differential output signals SIN\_P, SIN\_N, COS\_P and COS\_N are all connected to the four single-ended ADC channels in the external microcontroller. If differential ADC channels are available, then they are recommended. The load capacitors and resistors must match each other to achieve high accuracy. When a fault is detected, the outputs are placed in high-impedance state. TI recommends using pulldown or pullup resistors so that the external microcontroller can detect this case.

The TMAG6180-Q1 can drive capacitive loads up to 10nF directly on the AMR output pins. The device can also drive up to 100m capacitive loads through a cable with capacitances of 100pF/m. The device can drive resistive loads with the ability to source and sink currents up to 1mA.

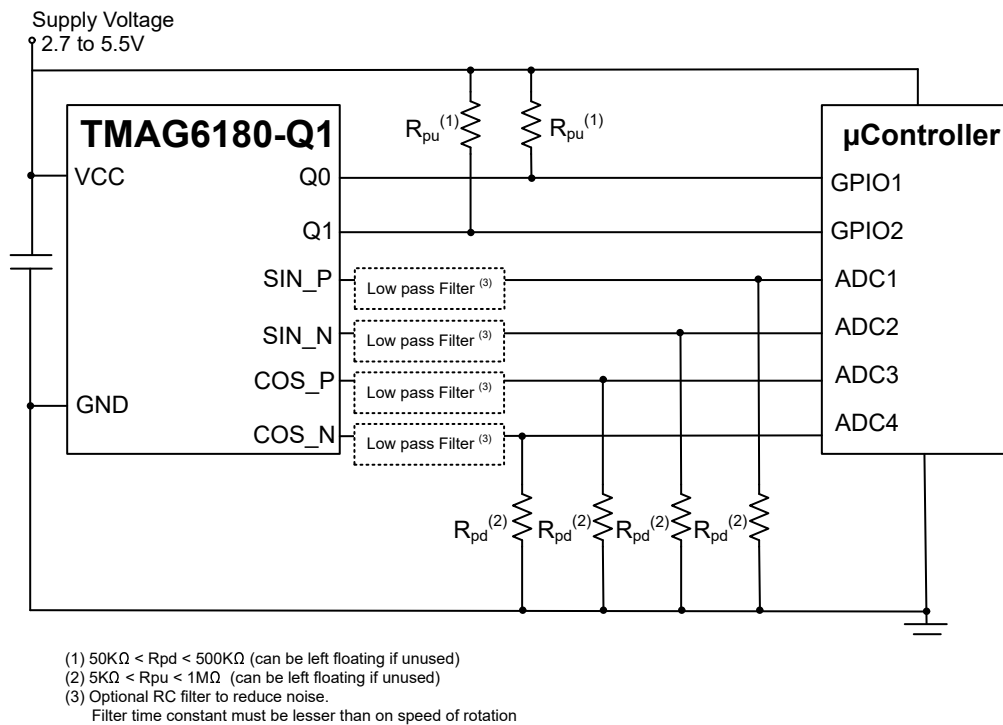

**Figure 7-2. Application Diagram for TMAG6180-Q1 in Differential-Ended Output Mode**

TI recommends using the single-ended output mode if the number of ADC ports in the microcontroller are limited, or if the number of wires from the sensor to the microcontroller must be kept to a minimum. Figure 7-3 shows a typical application circuit where only the positive output channels (SIN\_P and COS\_P) are connected to single-ended ADCs. The unused output signals (SIN\_N and COS\_N) can be either left floating or connected to ground through a high resistance. In single-ended output mode, the dynamic range (SNR) and noise immunity is typically reduced compared to the differential output mode. To reduce noise on the outputs and for filtering EMC disturbances, an external low-pass filter such as a first order RC network can be used. The bandwidth of the external filter must be designed based on the rotation speed of the magnetic field to be detected. TI recommends adding pullup or pulldown resistors to ground on the single-ended outputs (SIN\_P and COS\_P) so the outputs are defined when the outputs are in high-impedance state. The supply voltage of the sensor is used as the reference for the ADCs in the microcontroller.

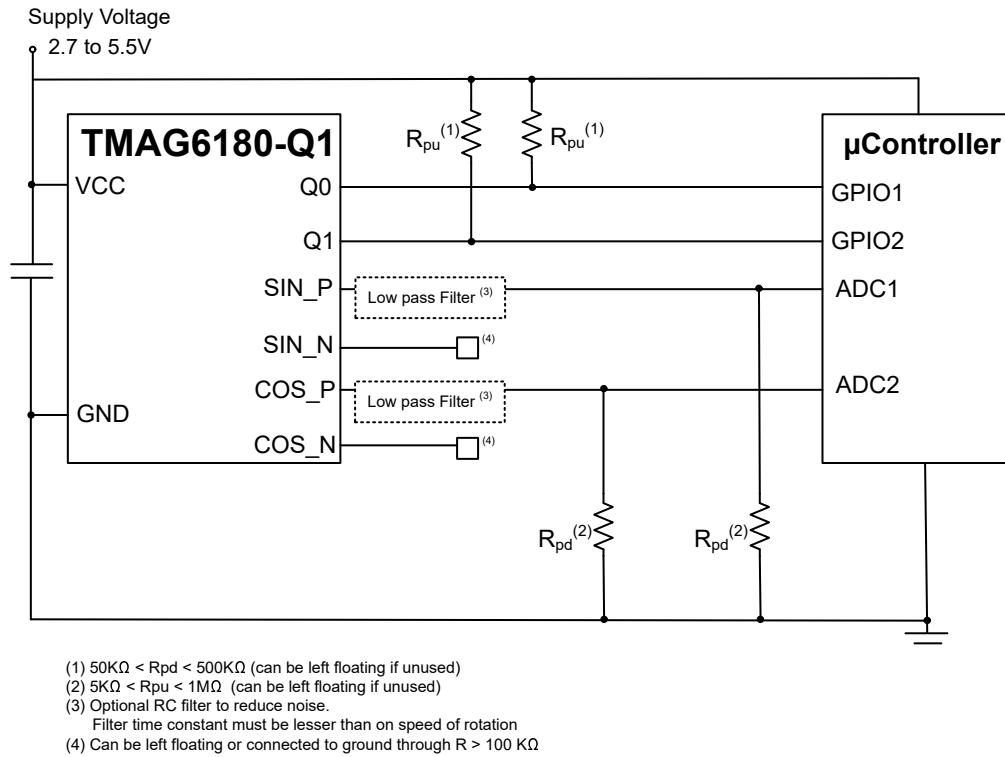

**Figure 7-3. Application Diagram for TMAG6180-Q1 in Single-Ended Output Mode**

### 7.2.1 Design Requirements

Figure 7-4 shows the center of the magnet aligned with the center of the sensor in a typical on-axis application.

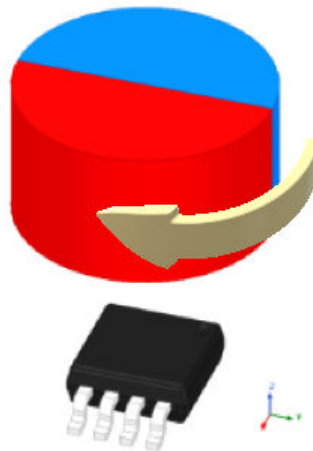

**Figure 7-4. On axis measurement setup for TMAG6180-Q1**

Use the parameters listed in [Table 7-1](#) for this design example

**Table 7-1. Design Parameters**

DESIGN PARAMETERS	ON-AXIS MEASUREMENT
V <sub>CC</sub>	5V
Magnet	Cylinder: 4.7625mm diameter, 12.7mm thick, neodymium N52, Br = 1480
Output mode	Differential-ended
Maximum speed of the motor	8,000 RPM
Desired Angle error across temperature	< 1°
Magnet to sensor placement	End of shaft

### 7.2.2 Detailed Design Procedure

For accurate angle measurement, the center of the magnet is aligned to the center of the sensor with acceptable tolerances. Follow these steps to calibrate the sensor for best accuracy:

- Reference angle calibration - Set the reference angle based on the magnet alignment to the sensor. This error can be saved in the microcontroller for runtime absolute position calculation. This error is also known as Angle offset in a system.
- Electrical offset calibration - See [Calibration of Sensor Errors](#) for the offset calibration procedure. If the sensor cannot be rotated across the full range, then the electrical offsets cannot be calibrated.
- Amplitude mismatch calibration - See [Calibration of Sensor Errors](#) for the amplitude mismatch calibration procedure. If the sensor cannot be rotated across the full range, then the amplitude mismatch cannot be calibrated.
- To extend the angle range from the AMR sensor to 360 degrees, see [Extending the Angle Range to 360 Degrees](#)

### 7.2.2.1 Extending the Angle Range to 360 Degrees

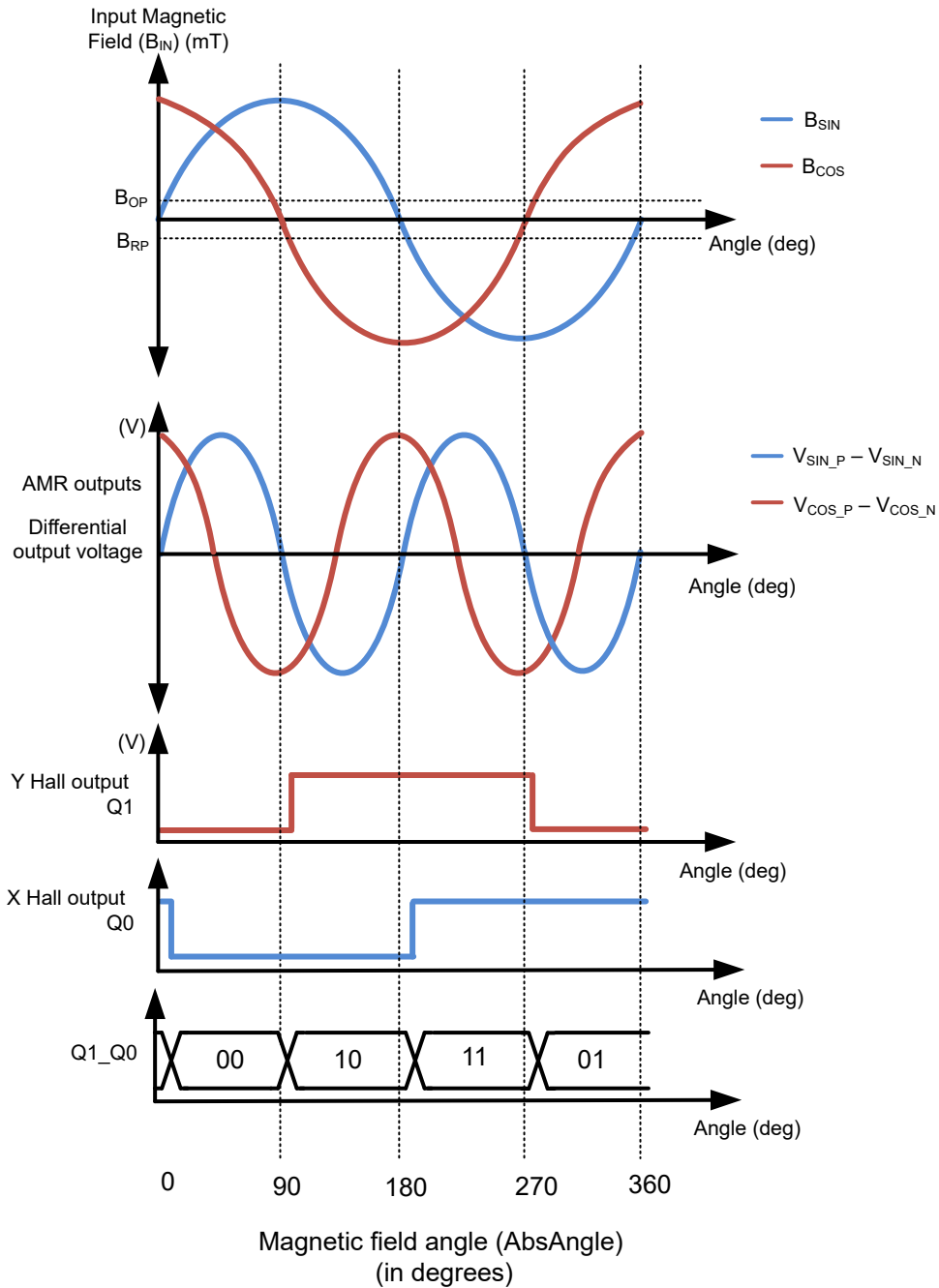

**Figure 7-5. Magnetic Response for a 360° Input Field**

Figure 7-5 shows the response of the differential-ended AMR output signals and the Hall outputs ( $Q_1$ ,  $Q_0$ ) for a 360° input magnetic field ( $B_{IN}$ ).

An example code for extending the angle range from 180 degrees to 360 degrees using the Q0, Q1 outputs is given below ;

```
MeasuredAngle = arctan2(SIN, COS)/2 ; //0-180° angle range , Multiply by 180/Pi if
the angle is returned in radians
```

```
MeasuredAngle = 90 - MeasuredAngle // If arctan2 function returns from -90deg to
90deg angle range, then use this to convert to 0-180° angle range
```

```
if (MeasuredAngle is between 45°-135°) then
```

```
(
```

```
if (Q1_Q0 is 00b or 10b) then //around 90°
```

```
AbsAngle = MeasuredAngle ;
```

```
else //Q1_Q0 is 11b or 01b, around 270°
```

```
AbsAngle = MeasuredAngle + 180°;
```

```
)
```

```
else //MeasuredAngle is 0°-45° or 135°-180°
```

```
(
```

```
if (Q1_Q0 is 00b or 01b) then //around 0°
```

```
(
```

```
if (MeasuredAngle ≥ 135°) then
```

```
AbsAngle = MeasuredAngle + 180°;
```

```
else
//MeasuredAngle is 0-45°
```

```
AbsAngle = MeasuredAngle;
```

```
)
```

```
else
//2Digital is 10b or 11b, around 180°
```

```
(
```

```
if (MeasuredAngle ≥ 135°) then
```

```
AbsAngle = MeasuredAngle;
```

```
else
//MeasuredAngle is 0-45°)
```

```
AbsAngle = MeasuredAngle + 180°;
```

```
)
```

```
)
```

### 7.2.3 Application Curves

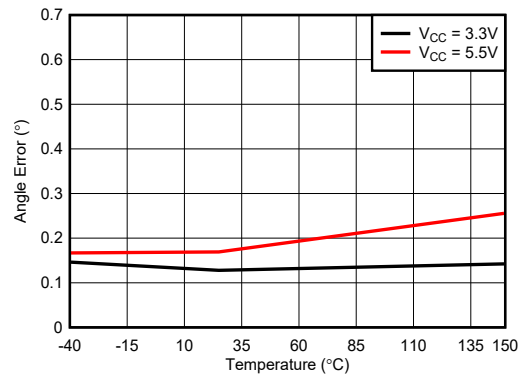

**Figure 7-6. Angle Error with Dynamic Calibration**

### 7.3 Power Supply Recommendations

A decoupling capacitor close to the device must be used to provide local energy with minimal inductance. TI recommends using a ceramic capacitor with a value of at least 0.1µF.

### 7.4 Layout

#### 7.4.1 Layout Guidelines

Magnetic fields pass through most nonferromagnetic materials with no significant disturbance. Embedding magnetic sensors within plastic or aluminum enclosures and sensing magnets on the outside is common practice. Magnetic fields also easily pass through most printed circuit boards (PCBs), which makes placing the magnet on the opposite side of the PCB possible.

#### 7.4.2 Layout Example

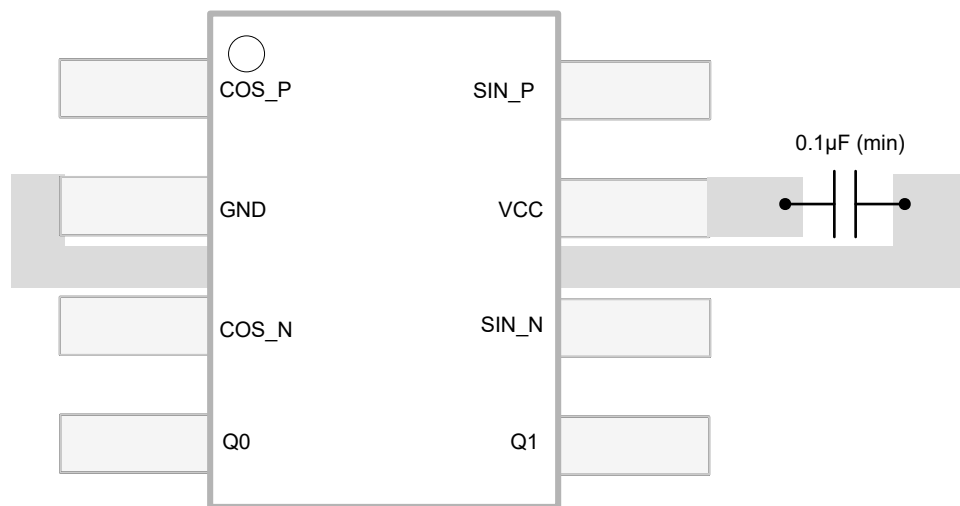

**Figure 7-7. Layout Example With TMAG6180-Q1**

## 8 Device and Documentation Support

### 8.1 Receiving Notification of Documentation Updates

To receive notification of documentation updates, navigate to the device product folder on [ti.com](https://www.ti.com). Click on *Notifications* to register and receive a weekly digest of any product information that has changed. For change details, review the revision history included in any revised document.

### 8.2 Support Resources

TI E2E™ [support forums](#) are an engineer's go-to source for fast, verified answers and design help — straight from the experts. Search existing answers or ask your own question to get the quick design help you need.

Linked content is provided "AS IS" by the respective contributors. They do not constitute TI specifications and do not necessarily reflect TI's views; see TI's [Terms of Use](#).

### 8.3 Trademarks

TI E2E™ is a trademark of Texas Instruments.

All trademarks are the property of their respective owners.

### 8.4 Electrostatic Discharge Caution



This integrated circuit can be damaged by ESD. Texas Instruments recommends that all integrated circuits be handled with appropriate precautions. Failure to observe proper handling and installation procedures can cause damage.

ESD damage can range from subtle performance degradation to complete device failure. Precision integrated circuits may be more susceptible to damage because very small parametric changes could cause the device not to meet its published specifications.

### 8.5 Glossary

[TI Glossary](#) This glossary lists and explains terms, acronyms, and definitions.

## 9 Revision History

Changes from Revision * (March 2023) to Revision A (March 2024)	Page
• Changed the data sheet status from: Advanced Information to: Production Data.....	1

## 10 Mechanical, Packaging, and Orderable Information

The following pages include mechanical, packaging, and orderable information. This information is the most current data available for the designated devices. This data is subject to change without notice and revision of this document. For browser-based versions of this data sheet, refer to the left-hand navigation.

## PACKAGING INFORMATION

Orderable part number	Status (1)	Material type (2)	Package   Pins	Package qty   Carrier	RoHS (3)	Lead finish/ Ball material (4)	MSL rating/ Peak reflow (5)	Op temp (°C)	Part marking (6)
<a href="#">TMAG6180EDGKRQ1</a>	Active	Production	VSSOP (DGK)   8	2500   LARGE T&R	Yes	SN	Level-1-260C-UNLIM	-40 to 150	6180
TMAG6180EDGKRQ1.B	Active	Production	VSSOP (DGK)   8	2500   LARGE T&R	Yes	SN	Level-1-260C-UNLIM	-40 to 150	6180

(1) **Status:** For more details on status, see our [product life cycle](#).

(2) **Material type:** When designated, preproduction parts are prototypes/experimental devices, and are not yet approved or released for full production. Testing and final process, including without limitation quality assurance, reliability performance testing, and/or process qualification, may not yet be complete, and this item is subject to further changes or possible discontinuation. If available for ordering, purchases will be subject to an additional waiver at checkout, and are intended for early internal evaluation purposes only. These items are sold without warranties of any kind.

(3) **RoHS values:** Yes, No, RoHS Exempt. See the [TI RoHS Statement](#) for additional information and value definition.

(4) **Lead finish/Ball material:** Parts may have multiple material finish options. Finish options are separated by a vertical ruled line. Lead finish/Ball material values may wrap to two lines if the finish value exceeds the maximum column width.

(5) **MSL rating/Peak reflow:** The moisture sensitivity level ratings and peak solder (reflow) temperatures. In the event that a part has multiple moisture sensitivity ratings, only the lowest level per JEDEC standards is shown. Refer to the shipping label for the actual reflow temperature that will be used to mount the part to the printed circuit board.

(6) **Part marking:** There may be an additional marking, which relates to the logo, the lot trace code information, or the environmental category of the part.

Multiple part markings will be inside parentheses. Only one part marking contained in parentheses and separated by a "~" will appear on a part. If a line is indented then it is a continuation of the previous line and the two combined represent the entire part marking for that device.

**Important Information and Disclaimer:** The information provided on this page represents TI's knowledge and belief as of the date that it is provided. TI bases its knowledge and belief on information provided by third parties, and makes no representation or warranty as to the accuracy of such information. Efforts are underway to better integrate information from third parties. TI has taken and continues to take reasonable steps to provide representative and accurate information but may not have conducted destructive testing or chemical analysis on incoming materials and chemicals. TI and TI suppliers consider certain information to be proprietary, and thus CAS numbers and other limited information may not be available for release.

In no event shall TI's liability arising out of such information exceed the total purchase price of the TI part(s) at issue in this document sold by TI to Customer on an annual basis.

## TAPE AND REEL INFORMATION



### QUADRANT ASSIGNMENTS FOR PIN 1 ORIENTATION IN TAPE



\*All dimensions are nominal

Device	Package Type	Package Drawing	Pins	SPQ	Reel Diameter (mm)	Reel Width W1 (mm)	A0 (mm)	B0 (mm)	K0 (mm)	P1 (mm)	W (mm)	Pin1 Quadrant
TMAG6180EDGKRQ1	VSSOP	DGK	8	2500	330.0	12.4	5.25	3.35	1.25	8.0	12.0	Q1

**TAPE AND REEL BOX DIMENSIONS**

\*All dimensions are nominal

Device	Package Type	Package Drawing	Pins	SPQ	Length (mm)	Width (mm)	Height (mm)
TMAG6180EDGKRQ1	VSSOP	DGK	8	2500	366.0	364.0	50.0

# DGK0008A



# PACKAGE OUTLINE

VSSOP - 1.1 mm max height

SMALL OUTLINE PACKAGE



4214862/A 04/2023

**NOTES:**

PowerPAD is a trademark of Texas Instruments.

1. All linear dimensions are in millimeters. Any dimensions in parenthesis are for reference only. Dimensioning and tolerancing per ASME Y14.5M.
2. This drawing is subject to change without notice.
3. This dimension does not include mold flash, protrusions, or gate burrs. Mold flash, protrusions, or gate burrs shall not exceed 0.15 mm per side.
4. This dimension does not include interlead flash. Interlead flash shall not exceed 0.25 mm per side.
5. Reference JEDEC registration MO-187.

# EXAMPLE BOARD LAYOUT

DGK0008A

™ VSSOP - 1.1 mm max height

SMALL OUTLINE PACKAGE



LAND PATTERN EXAMPLE  
EXPOSED METAL SHOWN  
SCALE: 15X



SOLDER MASK DETAILS

4214862/A 04/2023

NOTES: (continued)

6. Publication IPC-7351 may have alternate designs.
7. Solder mask tolerances between and around signal pads can vary based on board fabrication site.
8. Vias are optional depending on application, refer to device data sheet. If any vias are implemented, refer to their locations shown on this view. It is recommended that vias under paste be filled, plugged or tented.
9. Size of metal pad may vary due to creepage requirement.

# EXAMPLE STENCIL DESIGN

DGK0008A

<sup>TM</sup> VSSOP - 1.1 mm max height

SMALL OUTLINE PACKAGE



SOLDER PASTE EXAMPLE  
SCALE: 15X

4214862/A 04/2023

NOTES: (continued)

11. Laser cutting apertures with trapezoidal walls and rounded corners may offer better paste release. IPC-7525 may have alternate design recommendations.
12. Board assembly site may have different recommendations for stencil design.

## IMPORTANT NOTICE AND DISCLAIMER

TI PROVIDES TECHNICAL AND RELIABILITY DATA (INCLUDING DATASHEETS), DESIGN RESOURCES (INCLUDING REFERENCE DESIGNS), APPLICATION OR OTHER DESIGN ADVICE, WEB TOOLS, SAFETY INFORMATION, AND OTHER RESOURCES "AS IS" AND WITH ALL FAULTS, AND DISCLAIMS ALL WARRANTIES, EXPRESS AND IMPLIED, INCLUDING WITHOUT LIMITATION ANY IMPLIED WARRANTIES OF MERCHANTABILITY, FITNESS FOR A PARTICULAR PURPOSE OR NON-INFRINGEMENT OF THIRD PARTY INTELLECTUAL PROPERTY RIGHTS.

These resources are intended for skilled developers designing with TI products. You are solely responsible for (1) selecting the appropriate TI products for your application, (2) designing, validating and testing your application, and (3) ensuring your application meets applicable standards, and any other safety, security, regulatory or other requirements.

These resources are subject to change without notice. TI grants you permission to use these resources only for development of an application that uses the TI products described in the resource. Other reproduction and display of these resources is prohibited. No license is granted to any other TI intellectual property right or to any third party intellectual property right. TI disclaims responsibility for, and you fully indemnify TI and its representatives against any claims, damages, costs, losses, and liabilities arising out of your use of these resources.

TI's products are provided subject to [TI's Terms of Sale](#), [TI's General Quality Guidelines](#), or other applicable terms available either on [ti.com](#) or provided in conjunction with such TI products. TI's provision of these resources does not expand or otherwise alter TI's applicable warranties or warranty disclaimers for TI products. Unless TI explicitly designates a product as custom or customer-specified, TI products are standard, catalog, general purpose devices.

TI objects to and rejects any additional or different terms you may propose.

Copyright © 2025, Texas Instruments Incorporated

Last updated 10/2025

## Looking for pricing, stock, or lifecycle information?

Click below to explore more details on WIN SOURCE:

 [View TMAG6180EDGKRQ1 on WIN SOURCE](#)

 [Texas Instruments](#) Information

## Optimize Your Supply Chain with WIN SOURCE Solutions

-  Global Sourcing Solution
-  Obsolete Management
-  Cost Control Management
-  Shortage Management
-  Alternative Solution
-  Excess Inventory Management