

Product Description

An excellent alternative to traveling wave tube amplifiers, Qorvo’s Spatium™ QPR0220 is an integrated solid state, spatial-combining amplifier and driver amplifier with an operating range of 2–18 GHz while achieving 52.7 dBm (186 Watts) of instantaneous saturated power. With its maximum performance in output power, gain, efficiency, and power flatness, this Spatium is the ideal building block for microwave high power transmitters for EW and radar applications.

Qorvo’s patented and field-proven Spatium combining technology provides unprecedented Solid-State Power Amplifier (SSPA) performance in a rugged, compact size and weight which reduces total cost of ownership compared to alternative technologies. This product offering combines Qorvo’s market leadership in GaN technology and wideband MMIC design along with our high-count combining techniques for a best in class solution to power amplification.

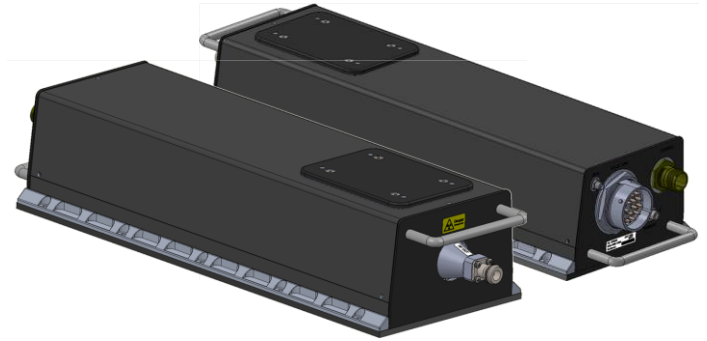

Output / Input

Functional Block Diagram

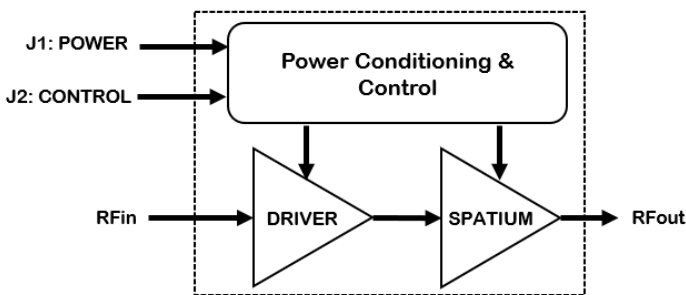

Product Features

- Frequency Range: 2 – 18 GHz
- Saturated Output Power: 52.7 dBm ($P_{IN} = 15$ dBm)
- Solid State MMIC Reliability
- Multi-Element Redundancy
- Instant On (no warm-up)

Performance is typical across frequency. Please reference electrical specification table and data plots for more details.

Applications

- TWTA Replacement

Ordering Information

Part No.	Description
QPR0220	2 – 18 GHz Spatium™ Amplifier

Absolute Maximum Ratings

Parameter ¹	Min Values	Max Values	Units
Supply Voltage (V_{DC}) ²		20	V
Power Supply Current	-	75	A
Enable Voltage (SYS ENABLE)	-	6.5	V
RF Input Power, Max.	-	30	dBm
Load VSWR		3:1	-
Storage Temperature	-55	85	°C

1. Operation of this device outside the parameter ranges given above may cause permanent damage. These are stress ratings only, and functional operation of the device at these conditions is not implied.
2. Rating for thermal reliability.

Recommended Operating Conditions

Parameter	Min	Typ	Max	Units
Power Supply Voltage (V_{DC})		18		V
Quiescent Current (Small Signal Applications)		46		A
Operating Current	See data plots			A
Temperature ¹	-40		71	°C
DC Pulse Width ²	0.5			uS

1. Refers to base surface temperature (T_{BASE}).
2. Unit can be DC or RF pulsed, this limit is applicable to DC pulsing only.

Electrical Specifications

Test conditions unless otherwise noted: $V_{DC} = 18\text{ V}$, $T_{BASE} = 25\text{ °C}$

Parameter ¹	Min	Typ	Max	Units
Frequency	2		18	GHz
Pulse Mode, Saturated Power ($P_{IN} = 15\text{ dBm}$) ²		53.5		dBm
Pulse Mode, Power-Added Efficiency ($P_{IN} = 15\text{ dBm}$) ²		19.0		%
Pulse Mode, Power Gain ($P_{IN} = 15\text{ dBm}$) ²		38.4		dB
CW Mode, Saturated Power ($P_{IN} = 15\text{ dBm}$)		52.7		
CW Mode, Power-Added Efficiency ($P_{IN} = 15\text{ dBm}$)		17.6		
CW Mode, Power Gain ($P_{IN} = 15\text{ dBm}$)		37.7		
Small Signal Gain		56.6		dB
Input Return Loss		15		dB
RF Pulsing Switching Time			30	nS
DC Pulsing Switching Time (ENABLE to 90% RF (ON))		182	200	nS
DC Pulsing Switching Time (ENABLE to 10% RF (OFF))		148	200	nS
Second Harmonic, CW (In band, $P_{IN} = 15\text{ dBm}$)		-23		dBc
Third Harmonic, CW (In band, $P_{IN} = 15\text{ dBm}$)		-16		dBc
Input RF Interface	SMA (F)			
Output RF Interface	Type N (F)			
Weight	26.0 (11.79)			lbs. (kg)
Dimensions (L) x (W) x (H)	19.5 x 6.3 x 3.9			inches
	495.3 x 160.0 x 99.1			millimeters

1. Electrical specifications are measured at specified test conditions or as shown in Recommended Operating Condition table. Specifications are not guaranteed over all recommended operating conditions.
2. Tested with DC pulsing. Pulse Width = 0.5 us, Duty Cycle 50%

Typical Performance – Large Signal (CW)

Test conditions unless noted: $V_{DC} = 18\text{ V}$, $P_{IN} = 15\text{ dBm}$, $T_{BASE} = \text{as shown}$

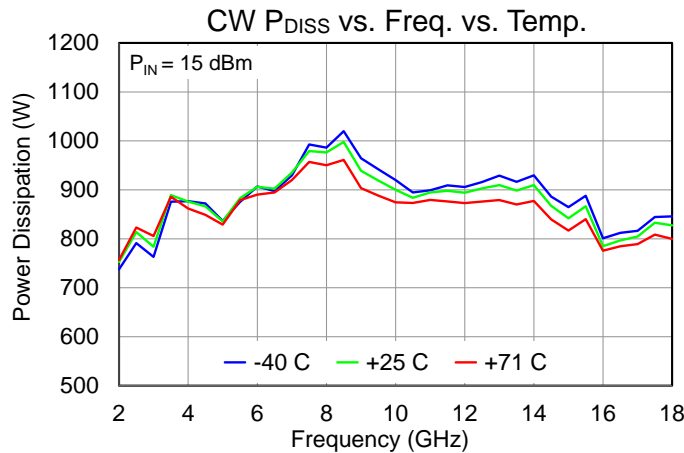
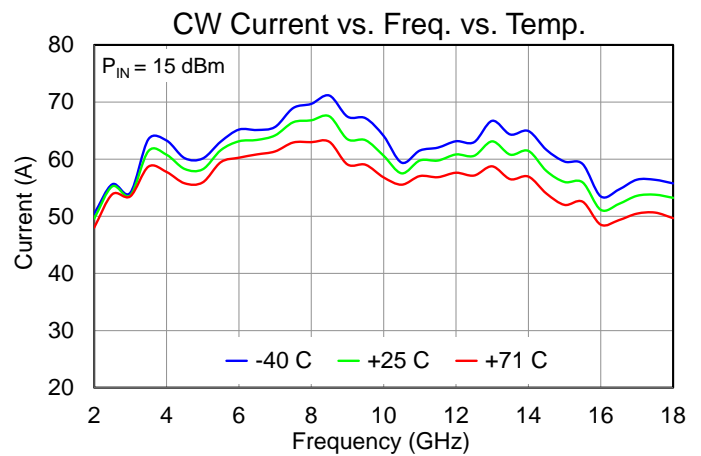
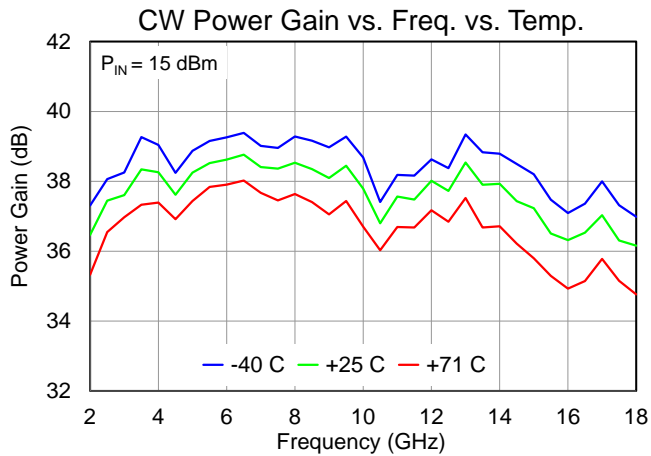
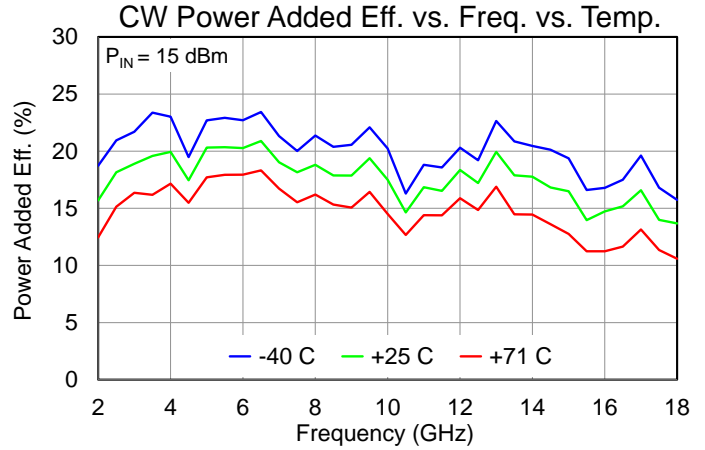
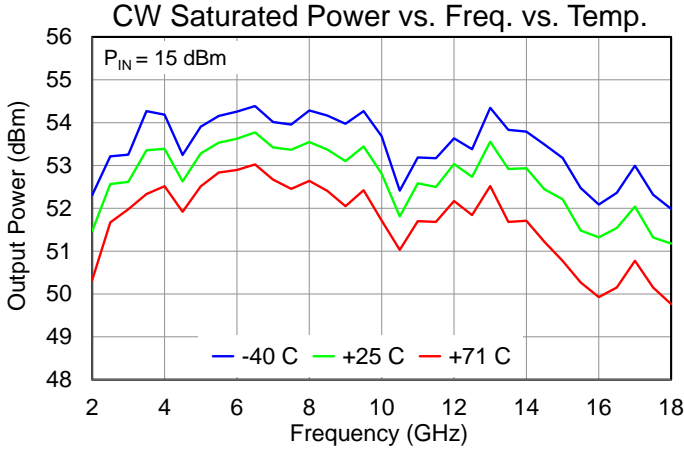

Typical Performance – Large Signal (CW)

Test conditions unless noted: $V_{DC} = 18\text{ V}$, $T_{BASE} = 25\text{ }^{\circ}\text{C}$

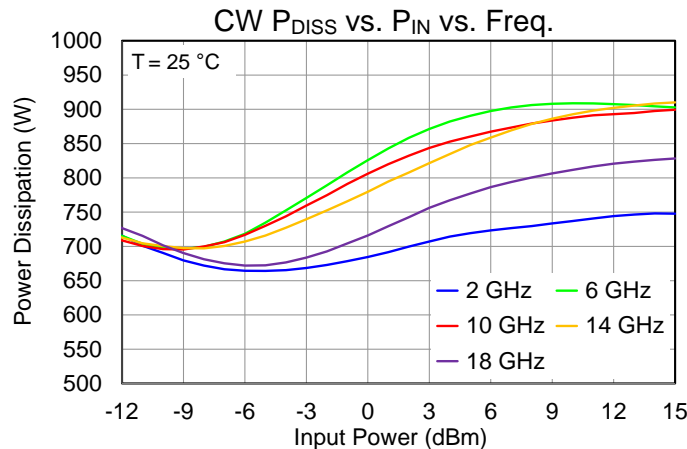
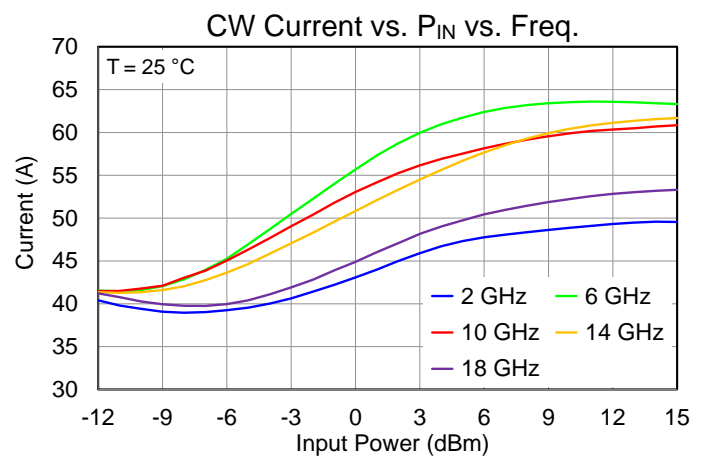
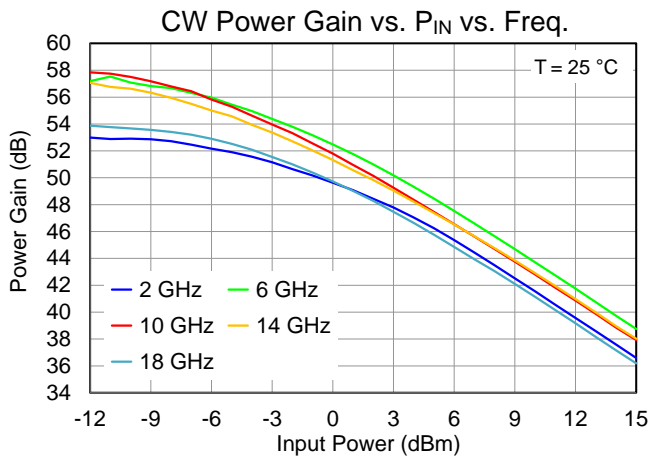
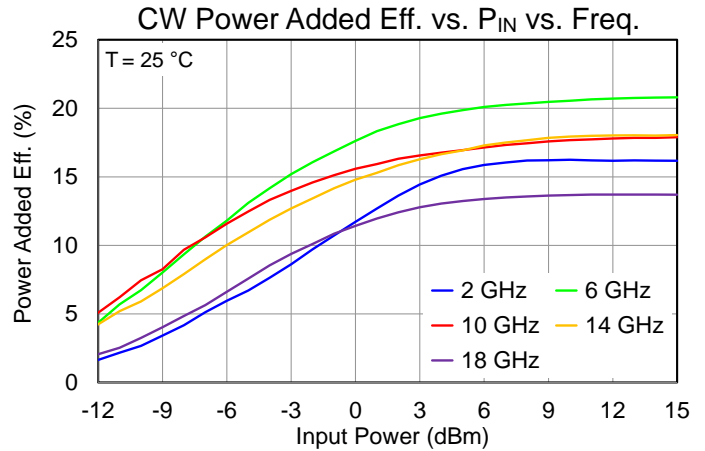
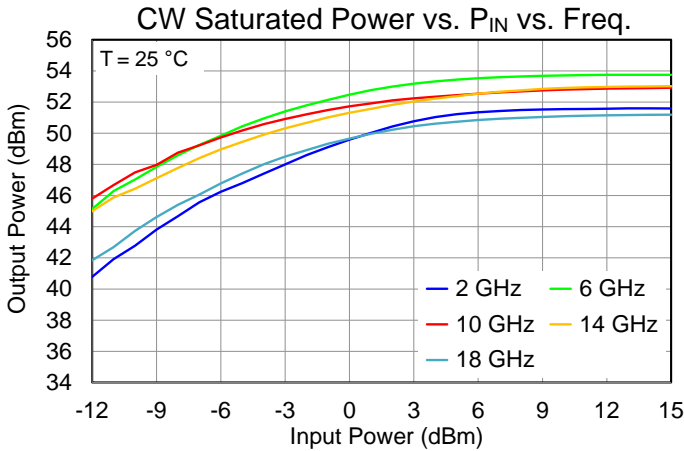

Typical Performance – Large Signal (CW)

Test conditions unless noted: $V_{DC} = 18\text{ V}$, $T_{BASE} =$ as shown

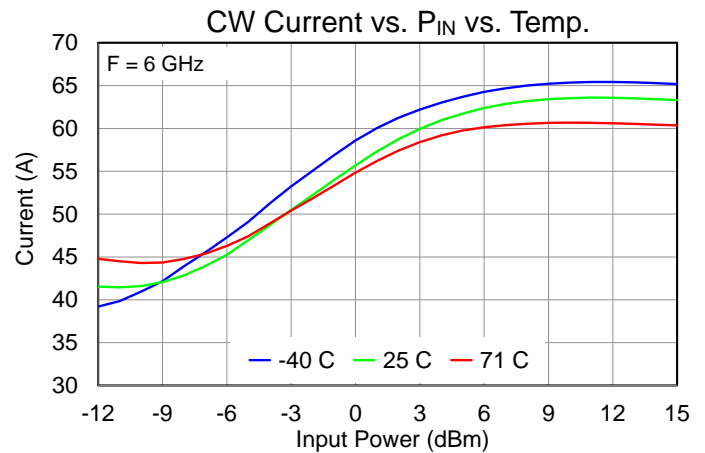
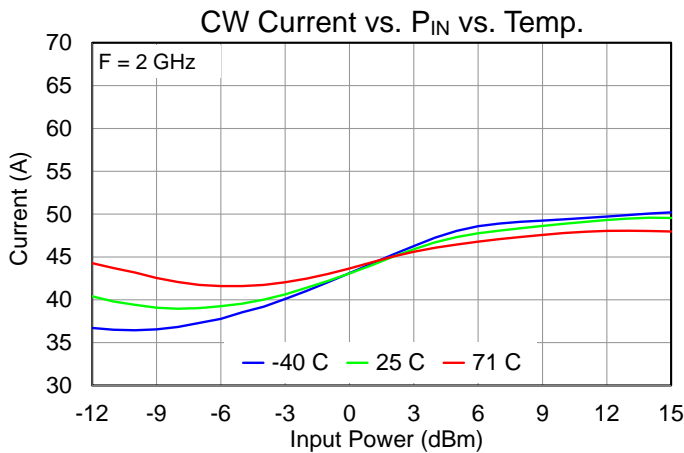
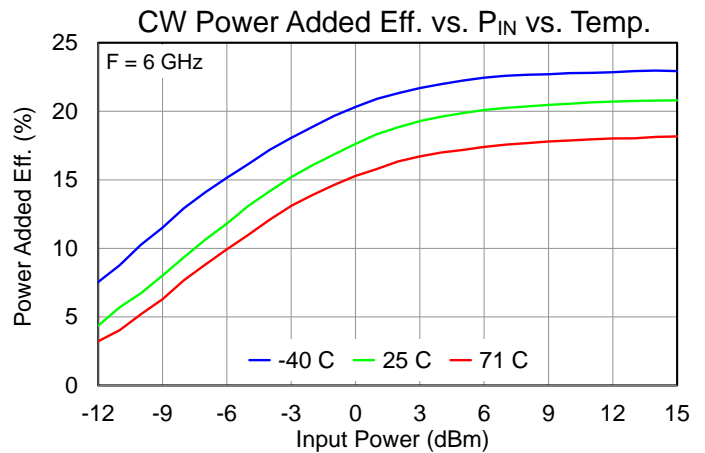
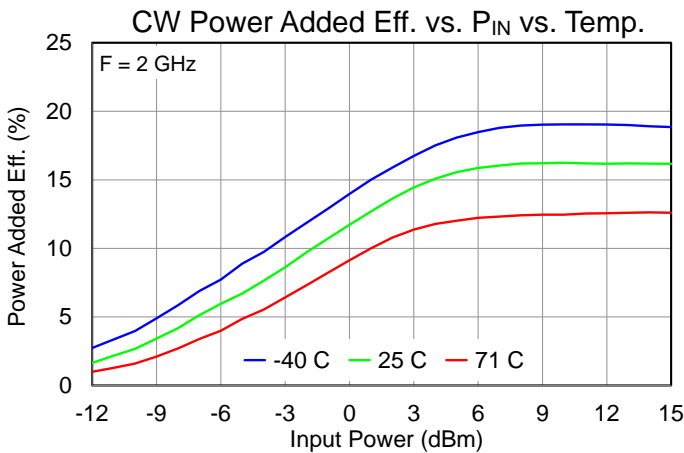
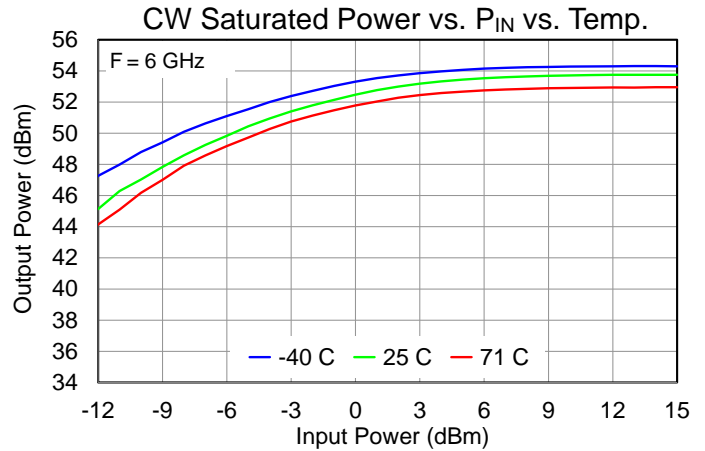
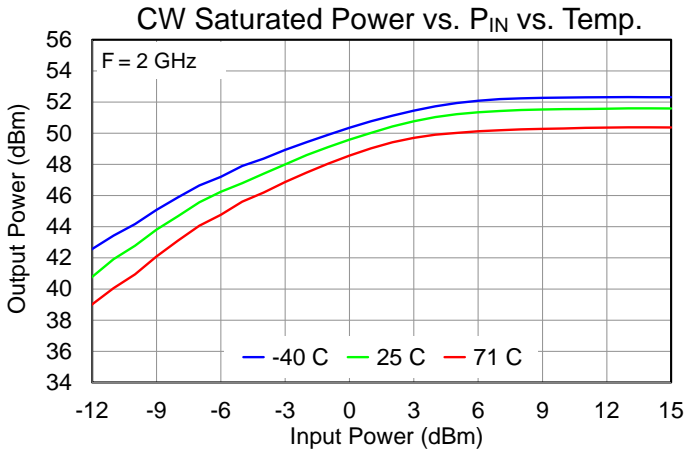

Typical Performance – Large Signal (CW)

Test conditions unless noted: $V_{DC} = 18\text{ V}$, $T_{BASE} =$ as shown

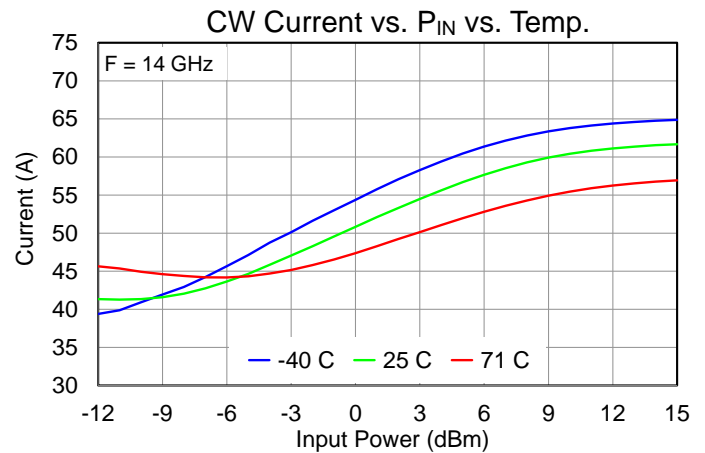
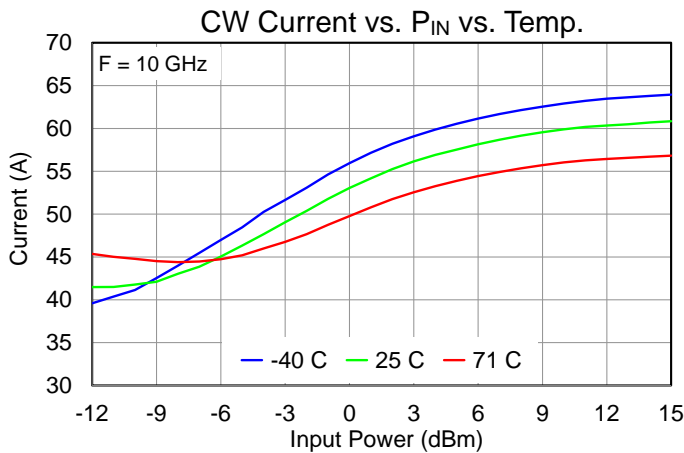
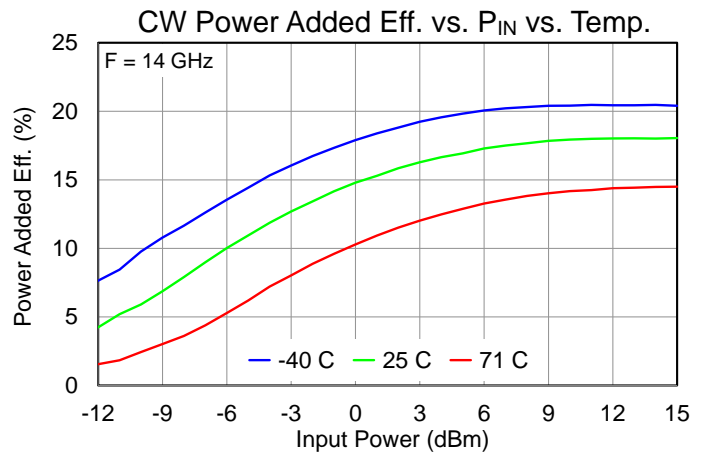
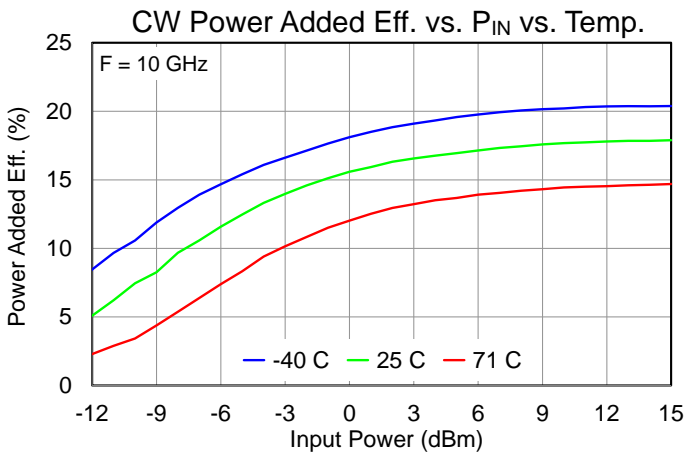
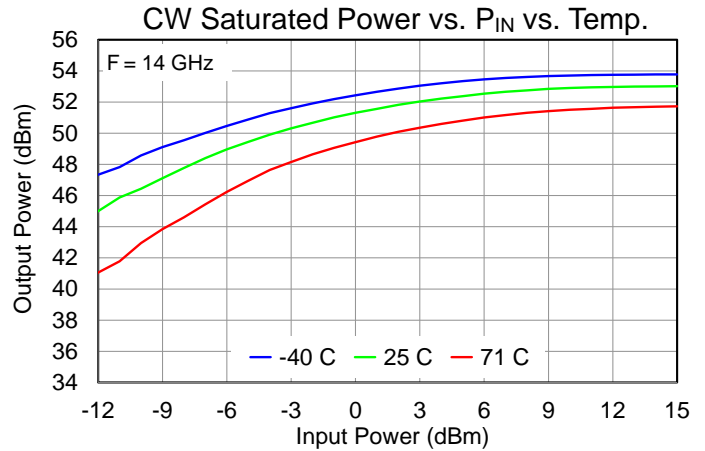
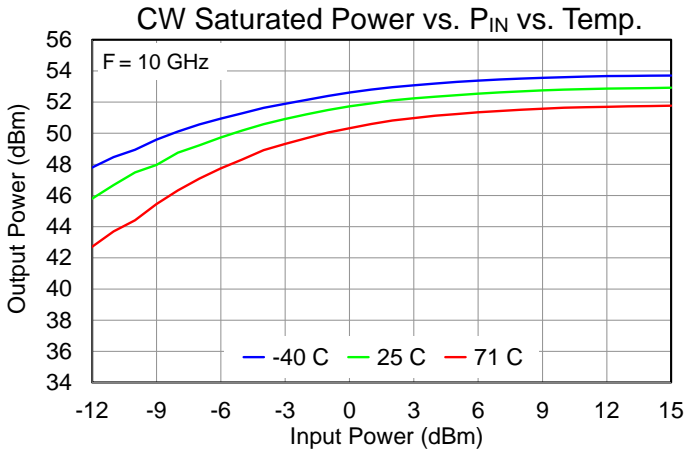

Typical Performance – Large Signal (CW)

Test conditions unless noted: $V_{DC} = 18\text{ V}$, $T_{BASE} = \text{as shown}$

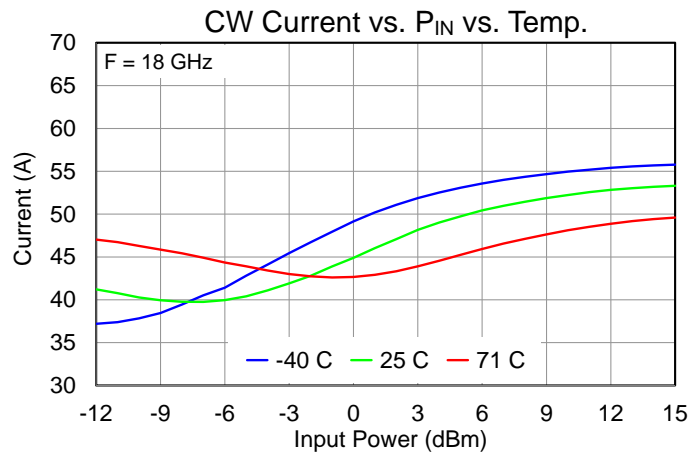
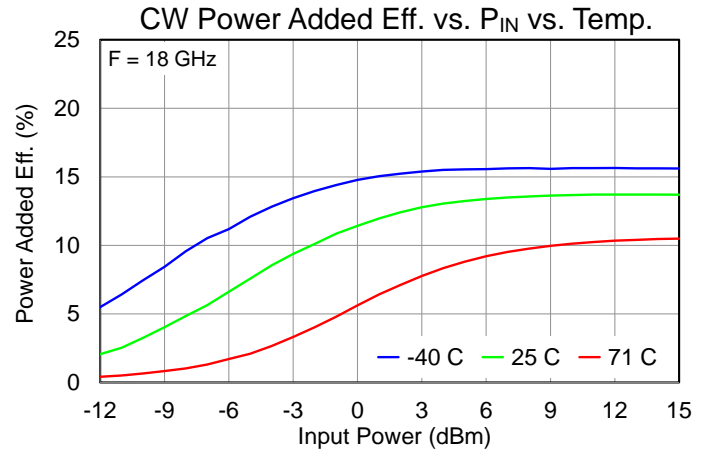
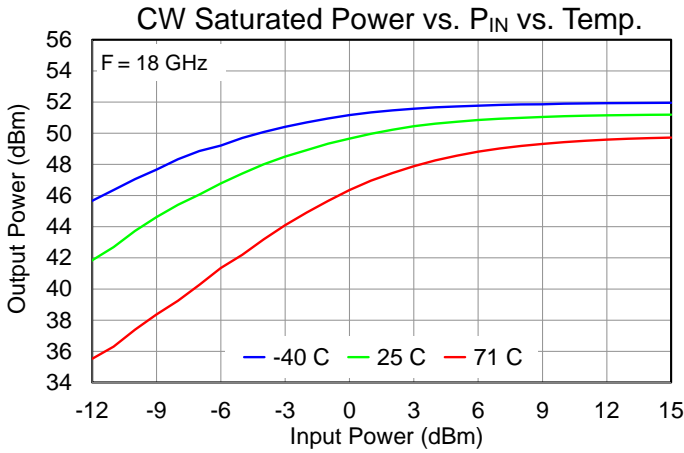

Typical Performance – Large Signal (Pulse)

Test conditions unless noted: $V_{DC} = 18\text{ V}$, Pulse Width = 0.5 μs , Duty Cycle 50%, $P_{IN} = 15\text{ dBm}$, $T_{BASE} = \text{as shown}$

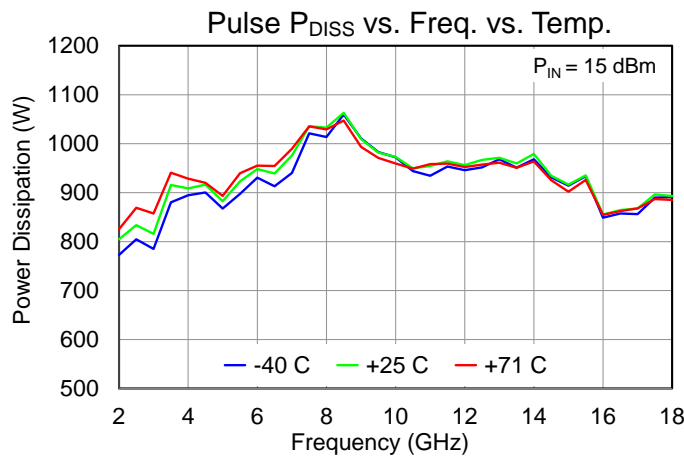
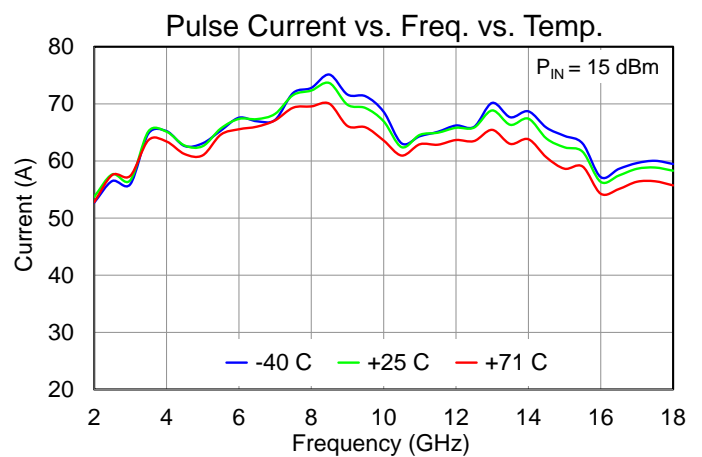
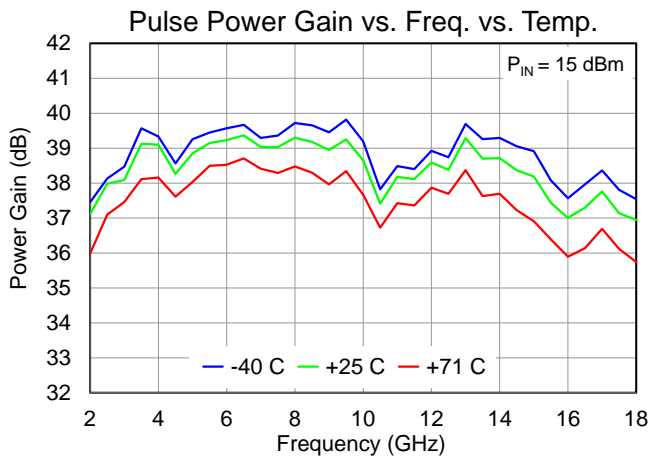
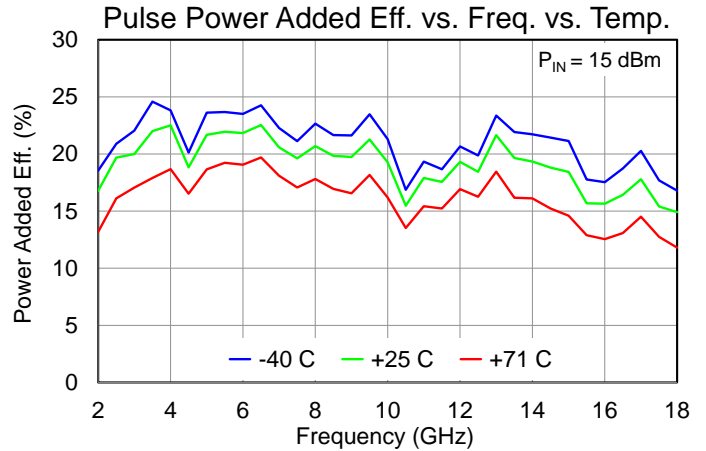
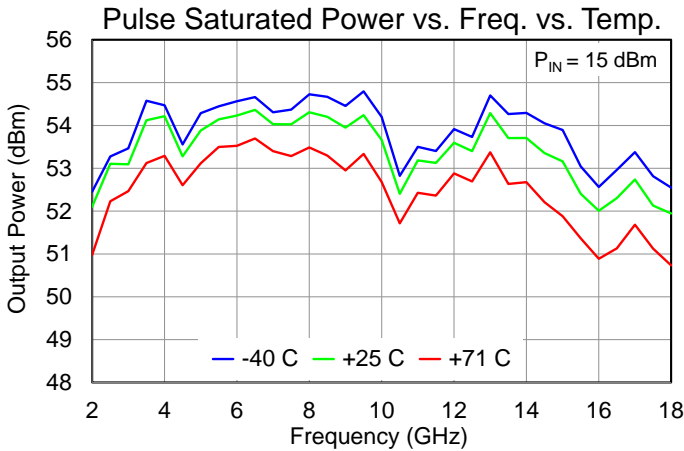

Typical Performance – Large Signal (Pulse)

Test conditions unless noted: $V_{DC} = 18\text{ V}$, Pulse Width = 0.5 us, Duty Cycle 50%, $P_{IN} = 15\text{ dBm}$, $T_{BASE} = 25\text{ }^{\circ}\text{C}$

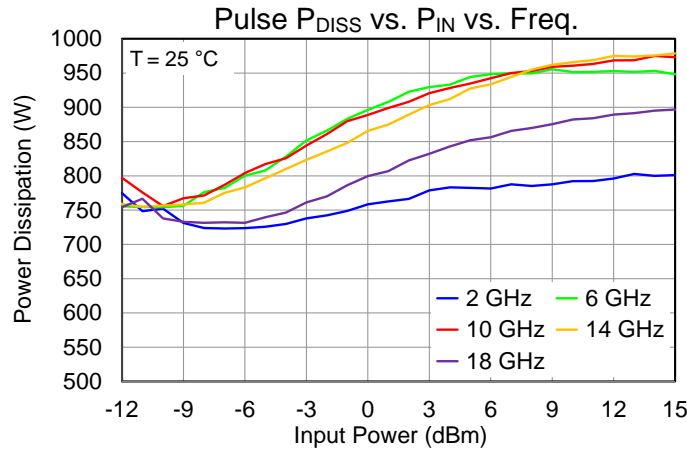
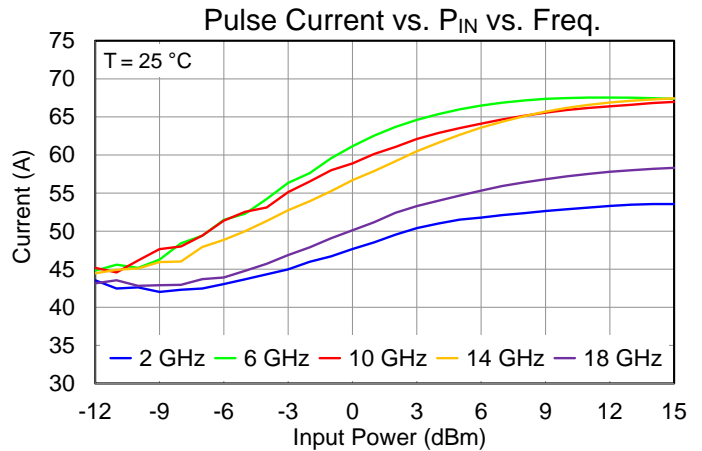
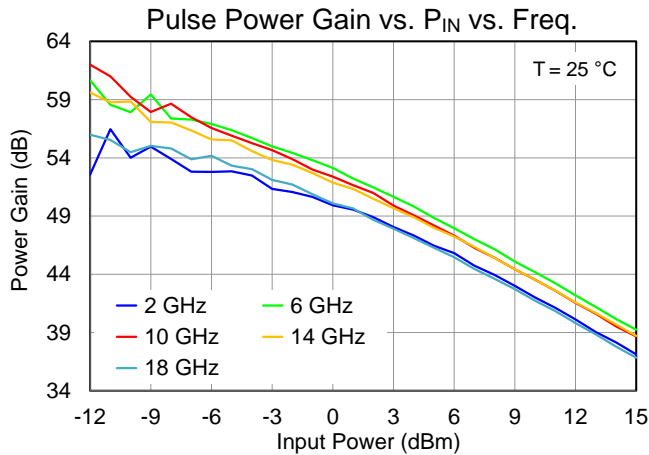
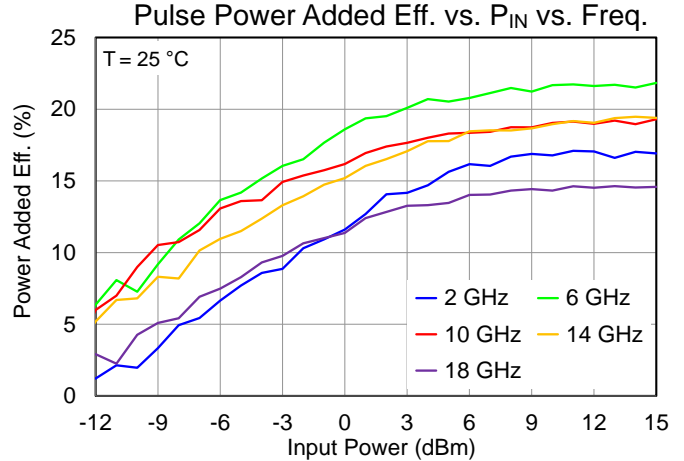
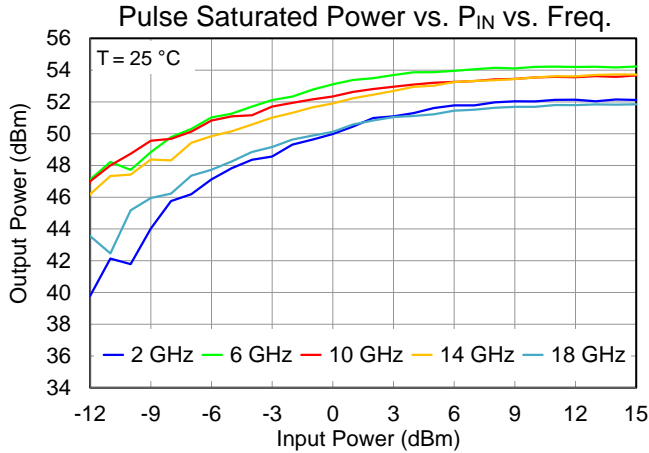

Typical Performance – Large Signal (Pulse)

Test conditions unless noted: $V_{DC} = 18\text{ V}$, Pulse Width = 0.5 μs , Duty Cycle 50%, $T_{BASE} =$ as shown

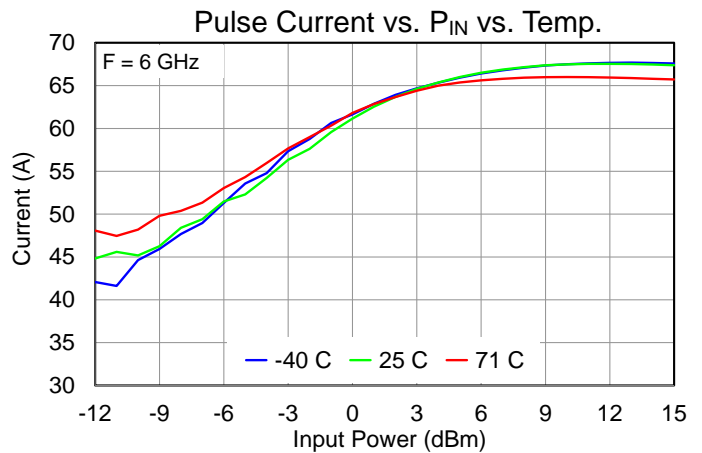
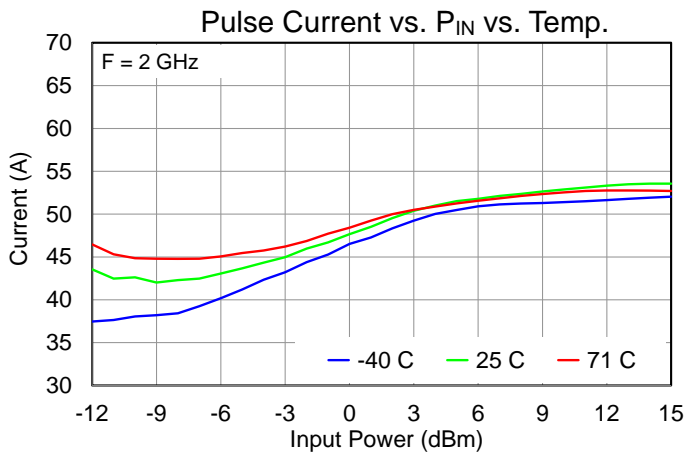
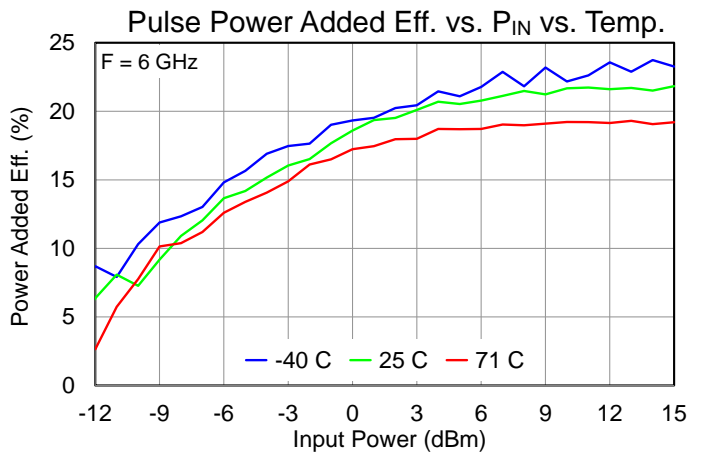
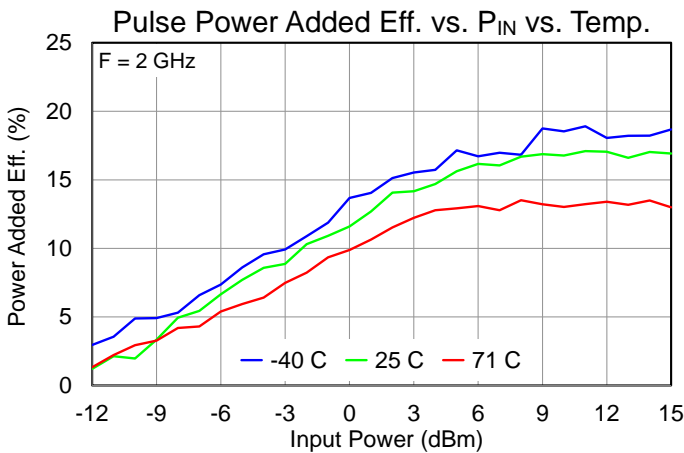
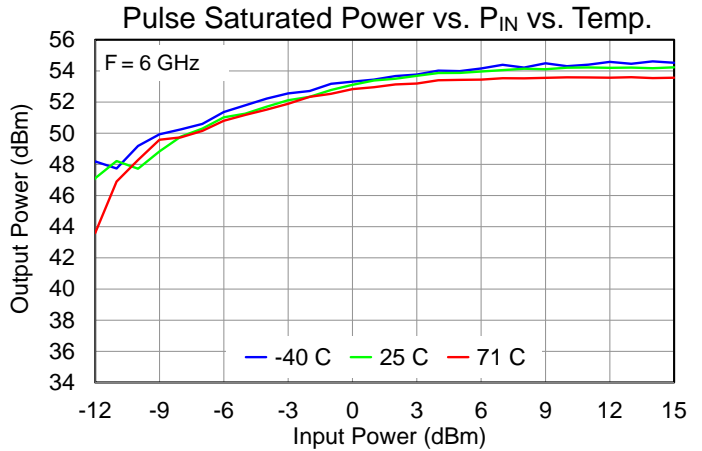
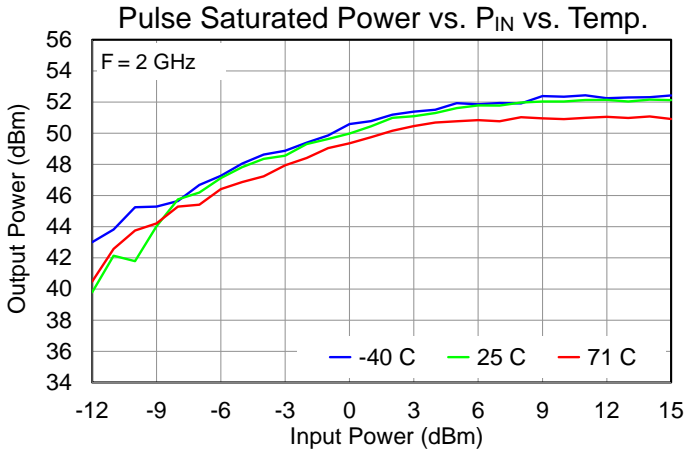

Typical Performance – Large Signal (Pulse)

Test conditions unless noted: $V_{DC} = 18\text{ V}$, Pulse Width = 0.5 μs , Duty Cycle 50%, $T_{BASE} =$ as shown

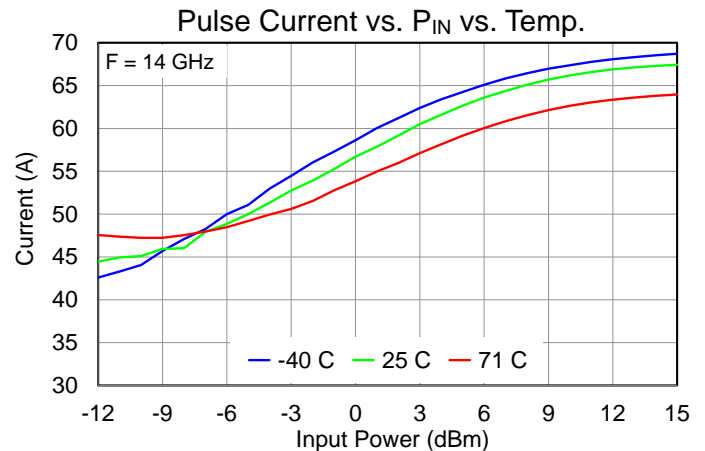
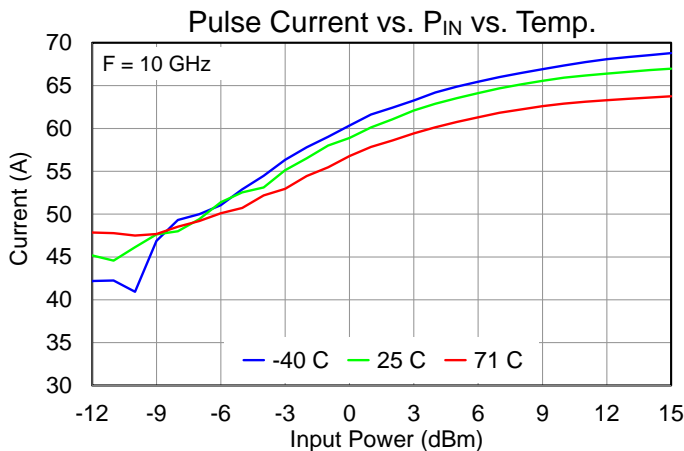
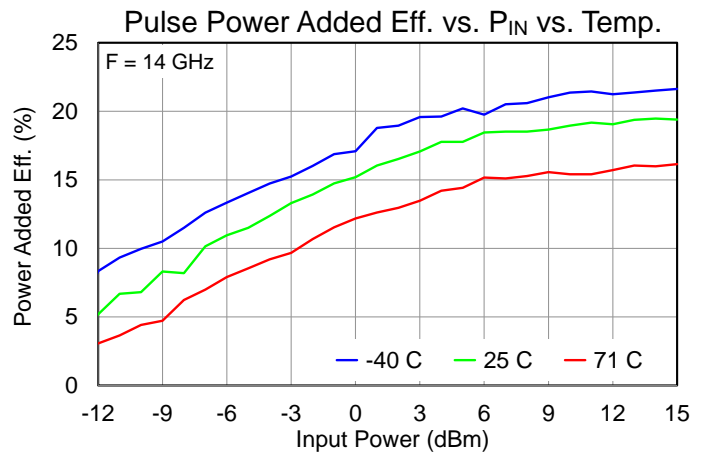
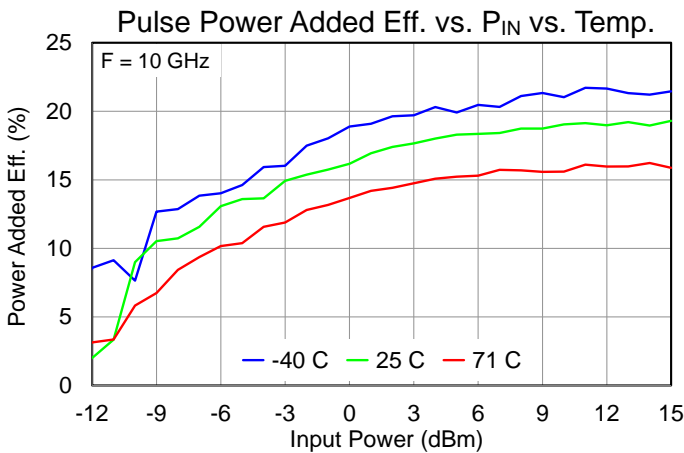
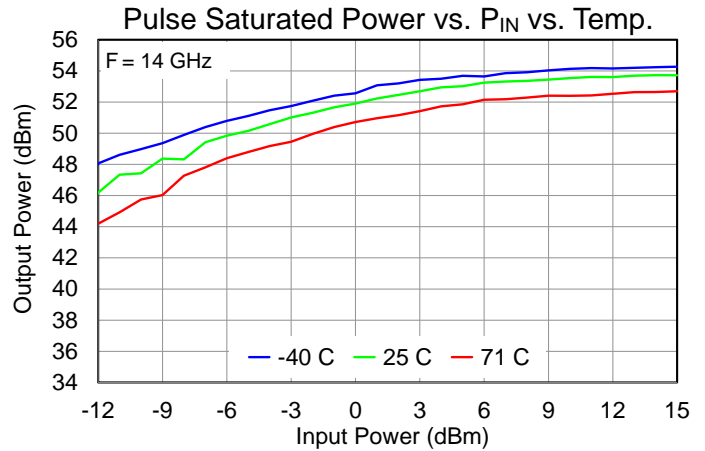
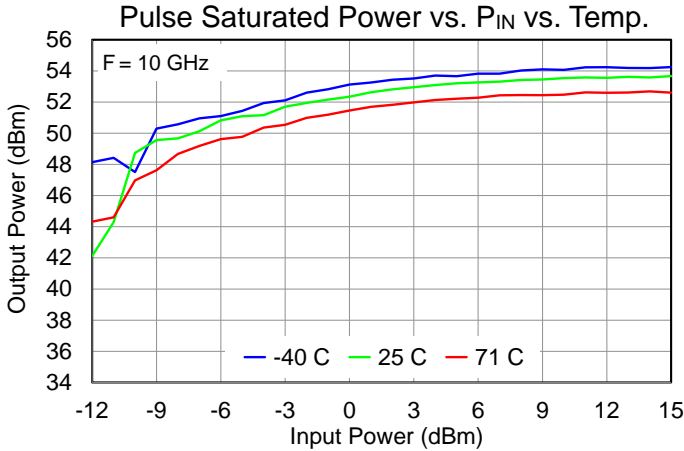

Typical Performance – Large Signal (Pulse)

Test conditions unless noted: $V_{DC} = 18\text{ V}$, Pulse Width = 0.5 μs , Duty Cycle 50%, $T_{BASE} = \text{as shown}$

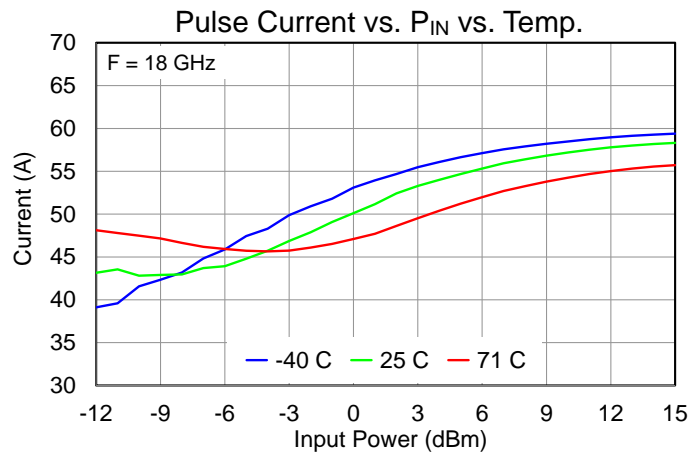
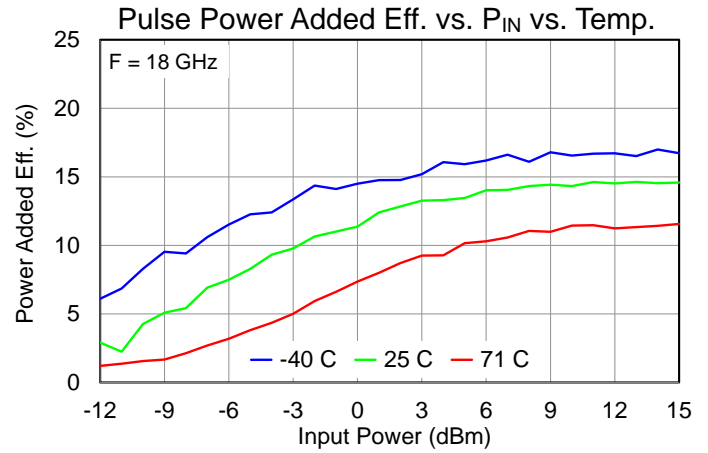
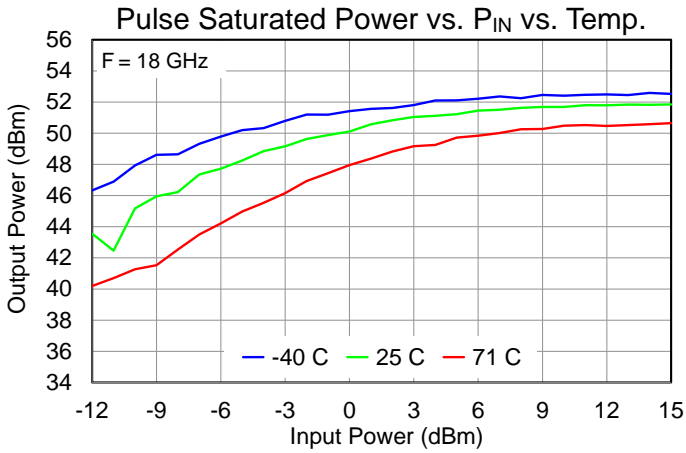

Typical Performance – Linearity (CW)

Test conditions unless otherwise noted: $V_{DC} = 18\text{ V}$, Tone Separation = 100 MHz, $T_{BASE} =$ as shown

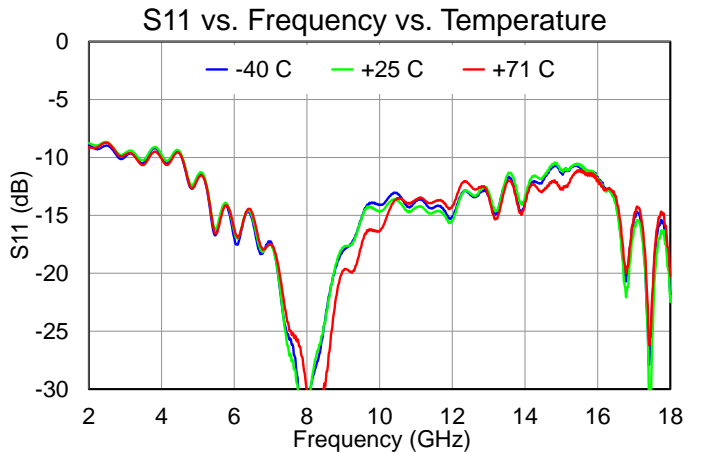
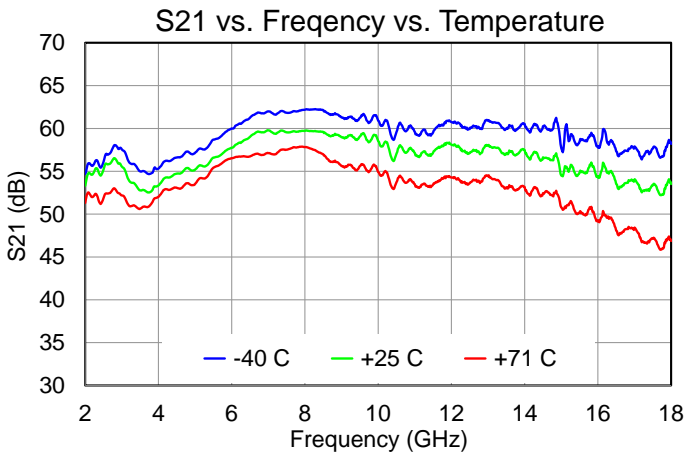
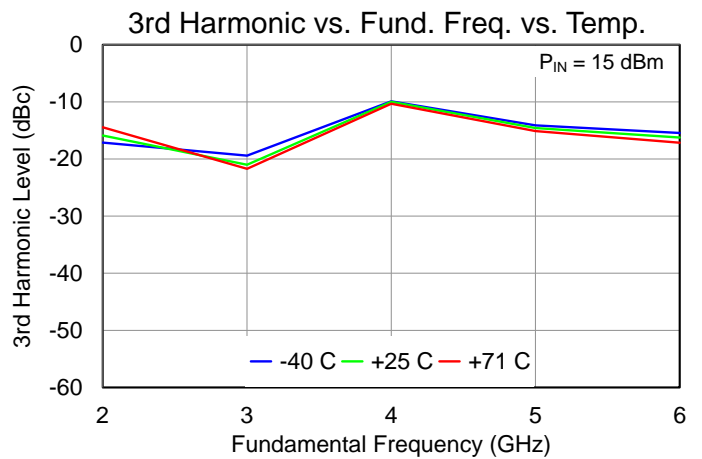
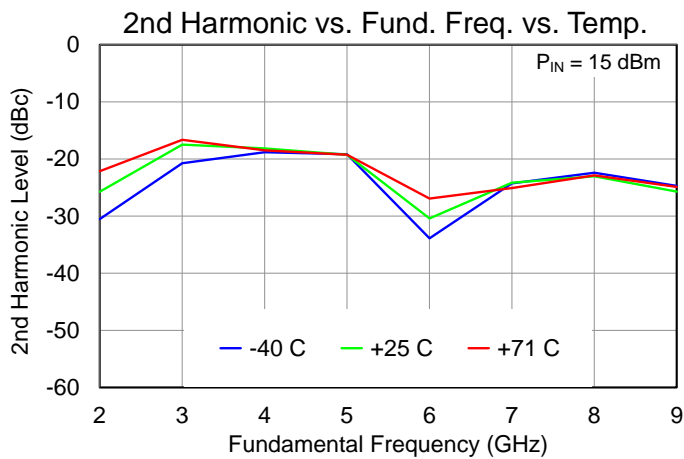
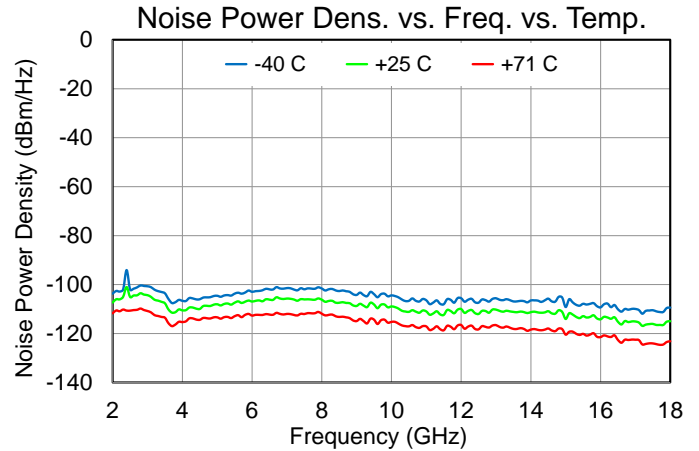
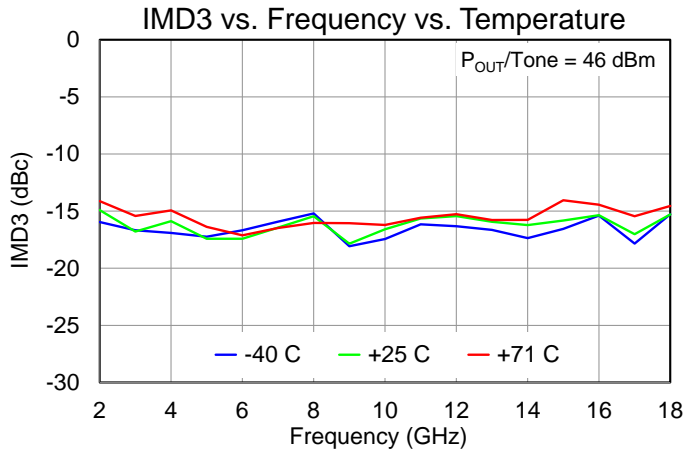

Block Diagram and Description

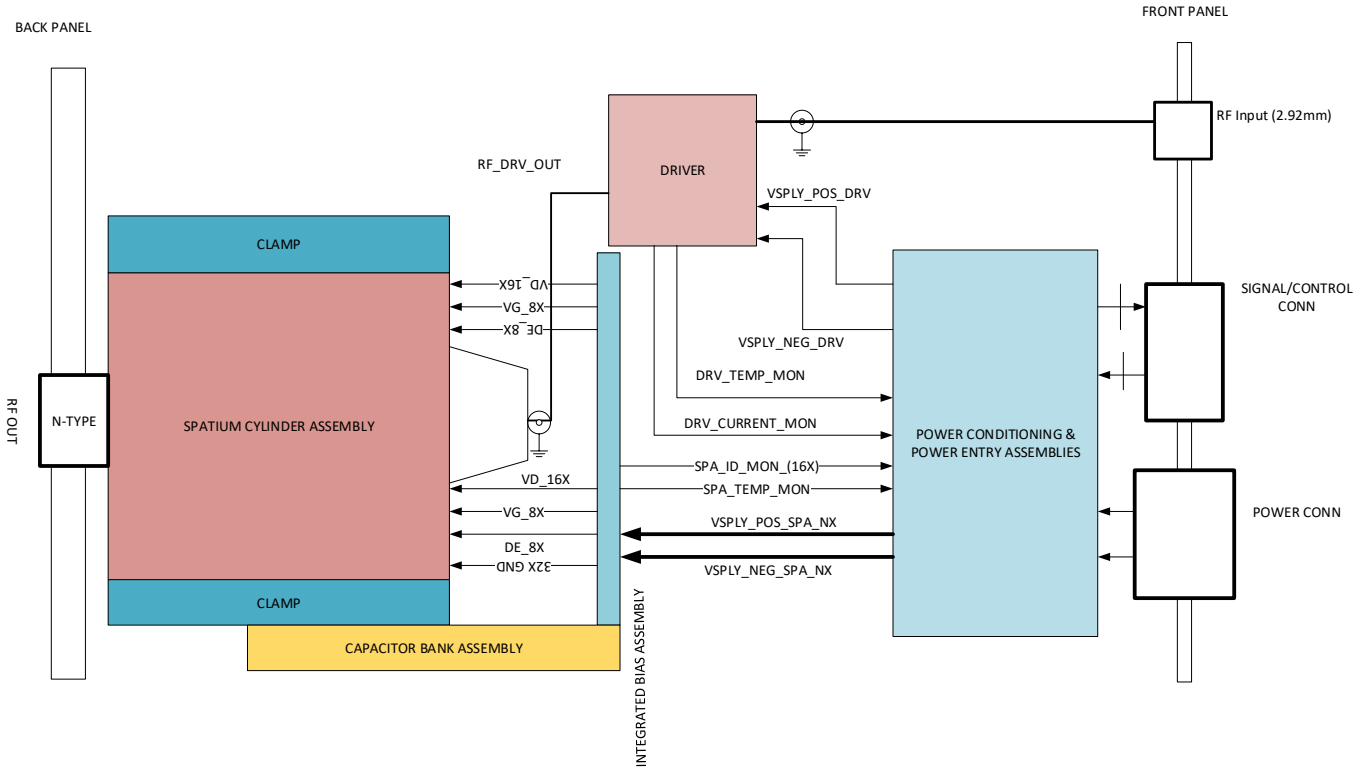

Pin No.	Label	Description
RF In	RF INPUT	2.92 mm (F) Coaxial RF Input, DC Coupled.
RF Out	RF OUTPUT	Type N (F) Coaxial RF Output, DC Grounded.
DC Power Input Connector	J1 POWER	TE CONNECTIVITY HD34-24-16PN, Mates with HD36-24-16SN.
Control Input Connector	J2 CONTROL	D38999/24FB35PN, Mates with M38999/26_B35SN.

Mechanical Information – Unit Outline Drawing

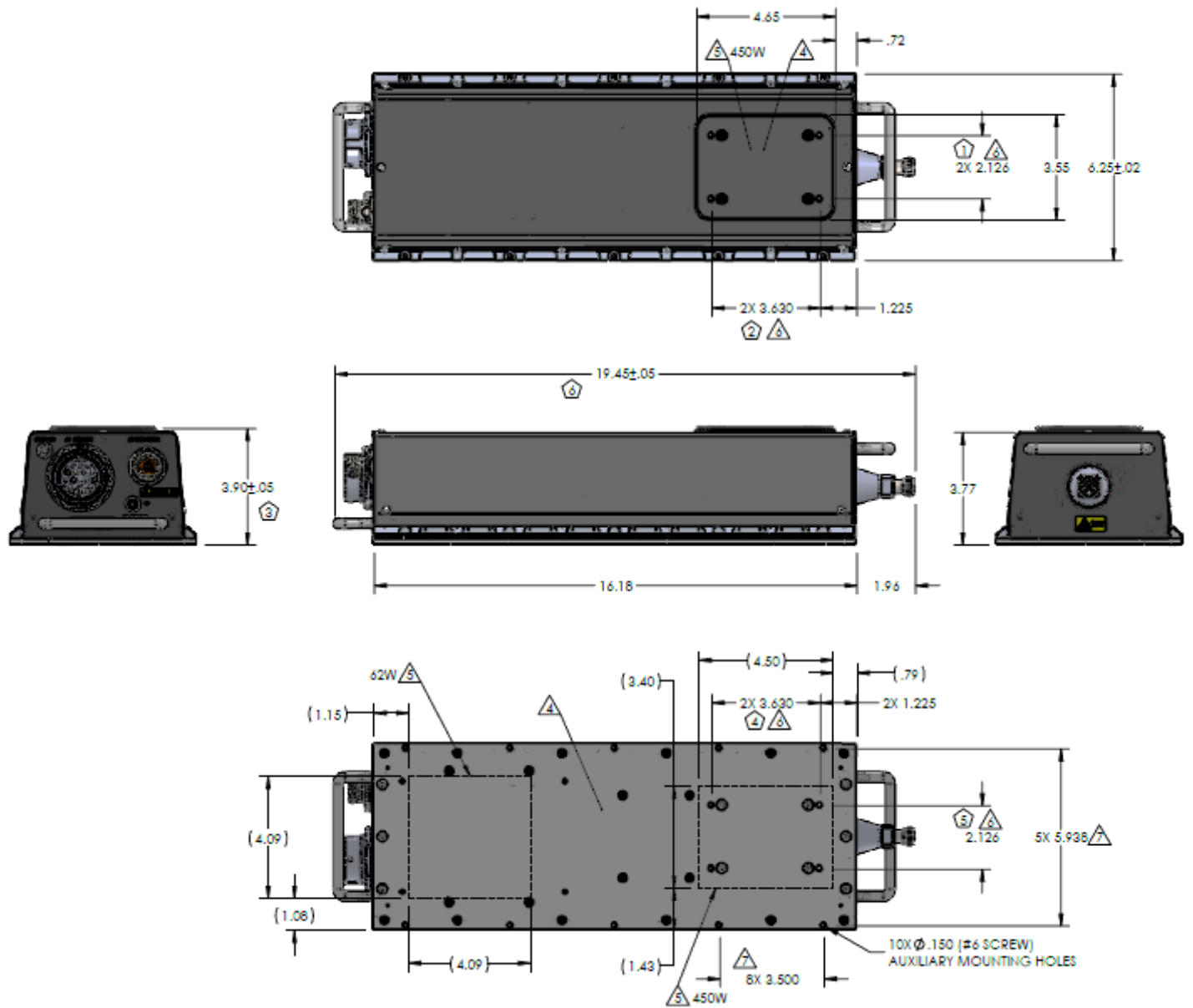

Dimensions are in INCHES

RF and Electrical Interface

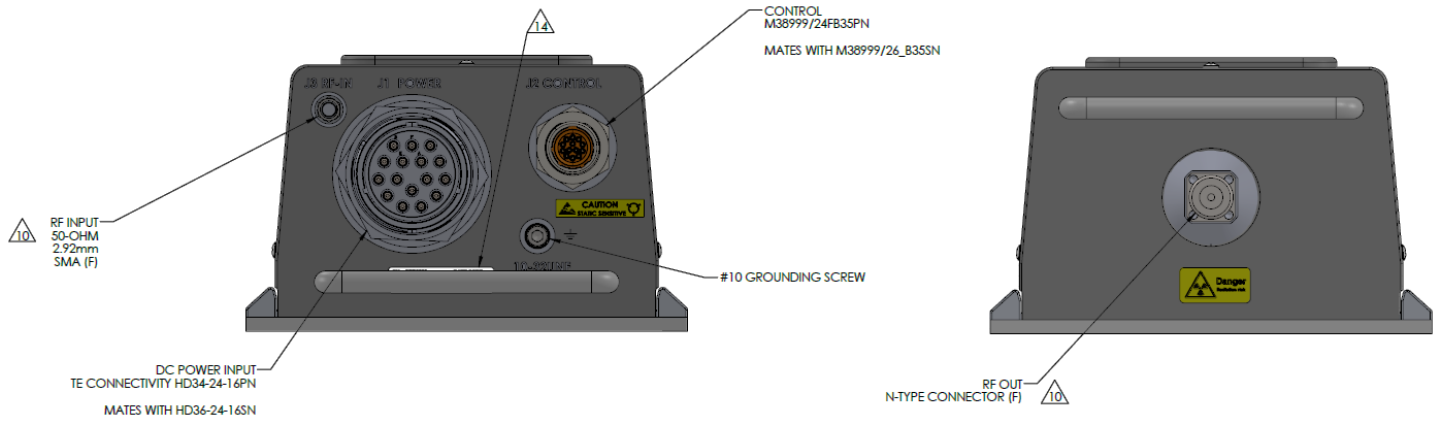

RF Ports	Functions	Descriptions
RFIN	RF Input	2.92 mm (F) coaxial RF input. DC coupled.
RFOUT	RF Output	Type N (F) coaxial RF output. DC grounded.

J1 Pins	Functions	Descriptions
J1-A, J1-D, J1-E, J1-F, J1-G, J1-H, J1-R, J1-S	V _{DC}	Prime power supplies.
J1-B, J1-C, J1-J, J1-K, J1-L, J1-M, J1-N, J1-P	DC GROUND	Power supply ground returns.

J2 Pins	Functions	Descriptions
J2-1	RESET	Reset, TTL. Pull to 0V to reset system. Leave open or set to +5V when not in use.
J2-2, J2-6	GROUND	Signal GND.
J2-3	SYS ENABLE	System Enable / Disable, TTL. For normal operation, set to +5V. For blank mode (no RF), set to 0V, this will disable all MMIC drain supplies. If left open, the amplifier will power on with application of prime power supply.
J2-4, J2-5, J2-11, J2-12, J2-13	N/C	No internal connections.
J2-7	SPA FAULT	SPA Status, TTL, 0V indicates the SPA (high power amplifier stage) operating normal, +5V indicates the SPA not in normal condition.
J2-8	DRV FAULT	Driver Status, TTL, 0V indicates the unit driver operating normal, +5V indicates the unit driver not in normal condition.
J2-9	SPA TEMP	SPA temperature monitor using TI - LMT87 sensor. - 40 °C = +3.2V; 25 °C = +2.3V, 71 °C = +1.7V.
J2-10	DRV TEMP	Driver stage temperature monitor using TI - LMT87 sensor. - 40 °C = +3.2V; 25 °C = +2.3V, 71 °C = +1.7V.

Handling Precautions



Caution!
ESD-Sensitive Device

RF VOLTAGE HAZARD: Contact with RF fields at the output connector can cause burns or electric shock. High levels of RF/Microwave energy may be present when the unit is operating.

HIGH DC CURRENT HAZARD: High levels of DC current are present when the unit is operating.

Contact Information

For the latest specifications, additional product information, worldwide sales and distribution locations:

Web: www.qorvo.com

Tel: 1-844-890-8163

Email: customer.support@qorvo.com

Important Notice

The information contained in this Data Sheet and any associated documents (“Data Sheet Information”) is believed to be reliable; however, Qorvo makes no warranties regarding the Data Sheet Information and assumes no responsibility or liability whatsoever for the use of said information. All Data Sheet Information is subject to change without notice. Customers should obtain and verify the latest relevant Data Sheet Information before placing orders for Qorvo® products. Data Sheet Information or the use thereof does not grant, explicitly, implicitly or otherwise any rights or licenses to any third party with respect to patents or any other intellectual property whether with regard to such Data Sheet Information itself or anything described by such information.

DATA SHEET INFORMATION DOES NOT CONSTITUTE A WARRANTY WITH RESPECT TO THE PRODUCTS DESCRIBED HEREIN, AND QORVO HEREBY DISCLAIMS ANY AND ALL WARRANTIES WITH RESPECT TO SUCH PRODUCTS WHETHER EXPRESS OR IMPLIED BY LAW, COURSE OF DEALING, COURSE OF PERFORMANCE, USAGE OF TRADE OR OTHERWISE, INCLUDING THE IMPLIED WARRANTIES OF MERCHANTABILITY AND FITNESS FOR A PARTICULAR PURPOSE. Without limiting the generality of the foregoing, Qorvo® products are not warranted or authorized for use as critical components in medical, life-saving, or life-sustaining applications, or other applications where a failure would reasonably be expected to cause severe personal injury or death. Applications described in the Data Sheet Information are for illustrative purposes only. Customers are responsible for validating that a particular product described in the Data Sheet Information is suitable for use in a particular application.

© 2025 Qorvo US, Inc. All rights reserved. This document is subject to copyright laws in various jurisdictions worldwide and may not be reproduced or distributed, in whole or in part, without the express written consent of Qorvo US, Inc. | QORVO® is a registered trademark of Qorvo US, Inc.

Looking for pricing, stock, or lifecycle information?

Click below to explore more details on WIN SOURCE:

 [View QPR0220 on WIN SOURCE](#)

 [Qorvo US Inc. Information](#)

Optimize Your Supply Chain with WIN SOURCE Solutions

-  Global Sourcing Solution
-  Obsolete Management
-  Cost Control Management
-  Shortage Management
-  Alternative Solution
-  Excess Inventory Management