

Product Description

An excellent alternative to traveling wave tube amplifiers, Qorvo’s Spatium™ QPB1316 is a solid state, spatial-combining amplifier with an operating range of 13.4–15.5 GHz while achieving greater than 57 dBm (500 Watts) of instantaneous saturated power. With its maximum performance in output power, gain, efficiency, and power flatness, this Spatium is the ideal building block for microwave high power transmitters for military and commercial applications. Liquid cooling capability provides excellent thermal management and reliable operation.

Qorvo’s patented and field-proven Spatium combining technology provides unprecedented Solid-State Power Amplifier (SSPA) performance in a rugged, compact size and weight which reduces total cost of ownership compared to alternative technologies. This product offering combines Qorvo’s market leadership in GaN technology and wideband MMIC design, along with our high-count combining techniques, for a best in class solution to power amplification.

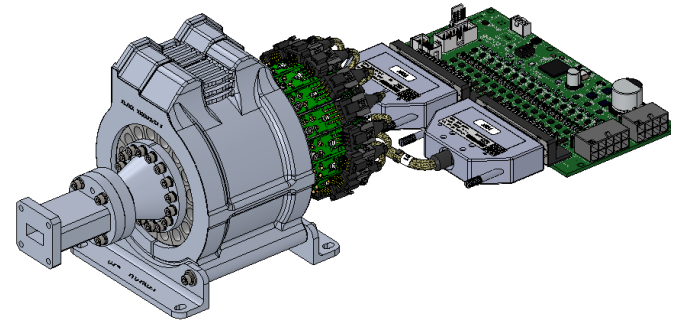

Functional Block Diagram

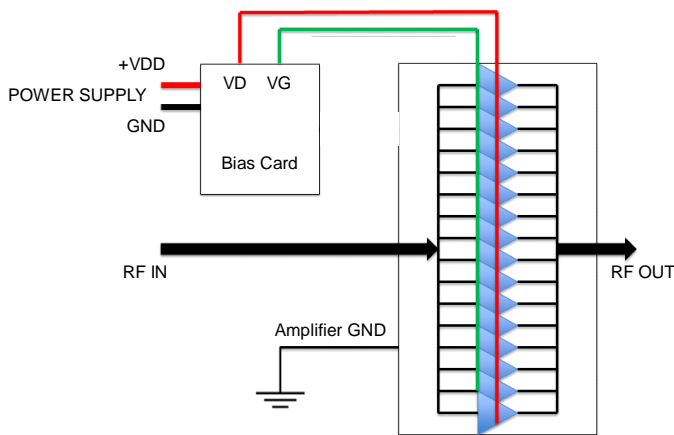

Product Features

- Frequency Range: 13.4 – 15.5 GHz
- Saturated Output Power: > 57 dBm
- Solid State MMIC Reliability
- Multi-Element Redundancy
- Instant On (no warm-up)

Performance is typical across frequency. Please reference electrical specification table and data plots for more details.

Applications

- TWTA Replacement

Ordering Information

Part No.	Description
QPB1316	13.4 – 15.5 GHz Spatium™ Amplifier

Absolute Maximum Ratings

Parameter	Value / Range
Prime Power (V_{DC})*	30 V
Drain Current (I_{D_DRIVE})	115 A
Output VSWR	3:1
RF Input Power, max.	43 dBm
Storage Temperature	-40 to +85 °C
Coolant Inlet Pressure	80 PSI

Operation of this device outside the parameter ranges given above may cause permanent damage. These are stress ratings only, and functional operation of the device at these conditions is not implied.

* Rating for thermal reliability

Recommended Operating Conditions

Parameter	Value / Range
Drain Voltage (V_D)	28 V
Quiescent Drain Current (I_{DQ})	14.4 A
Operating Drain Current (I_D at P_{SAT})	85 A
Ambient Operating Temperature**	-40 to +75 °C
Coolant Input Temperature	0 to +26 °C
Coolant Flow Rate	1.0 to 3.4 GPM

Electrical specifications are measured at specified test conditions. Specifications are not guaranteed over all recommended operating conditions.

**Some coolants have freezing temperatures within this range. Allowing coolant to freeze in the device will cause permanent damage.

Electrical Specifications

Test conditions unless otherwise noted: $V_D = 28$ V, $I_{DQ} = 14.4$ A, $P_{IN} = 34$ dBm, $T_{COOLANT} = 26$ °C, CW Operation

Parameter	Min	Typ	Max	Units
Frequency	13.4		15.5	GHz
Saturated P_{OUT} , CW ($P_{IN} = 34$ dBm)		57.8		dBm
Power-Added Efficiency, CW ($P_{IN} = 34$ dBm)		26.2		%
Power Gain, CW ($P_{IN} = 34$ dBm)		23.8		dB
Small Signal Gain		≥ 32.8		dB
Input Return Loss		≥ 8		dB
Output Return Loss		≥ 8		dB
IMD3, CW (1 MHz spacing, $P_{OUT/TONE} = 49$ dBm)		≤ -26		dBc
IMD5, CW (1 MHz spacing, $P_{OUT/TONE} = 49$ dBm)		≤ -34		dBc
Input RF Interface	SMA(F)			
Output RF Interface	WR62 Waveguide / UG419/U Flange			
Weight (Amplifier Unit, Bias Card, Cable, Coolant)	12.0 (5.44)			lbs. (kg)
Dimensions – Amplifier Unit (L) x (W) x (H)	9.4 x 5.5 x 5.0			inches
	238.8 x 139.7 x 127.0			millimeters

Typical Performance – Large Signal (CW)

Test conditions unless otherwise noted: $V_D = 28\text{ V}$, $I_{DQ} = 14.4\text{ A}$, $P_{IN} = 34\text{ dBm}$, $T_{COOLANT} = 26\text{ °C}$, CW Operation

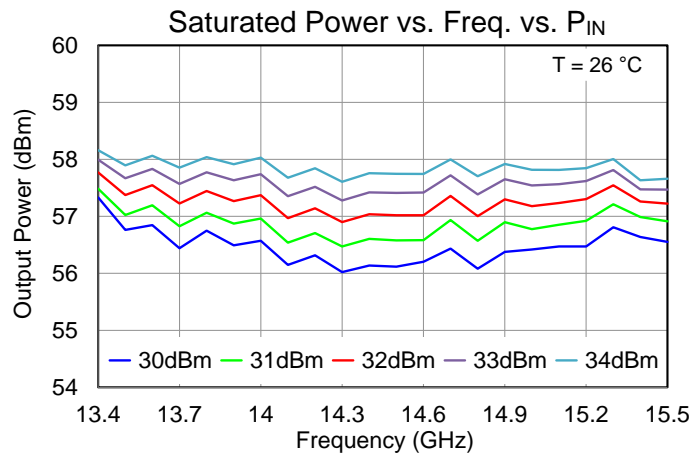
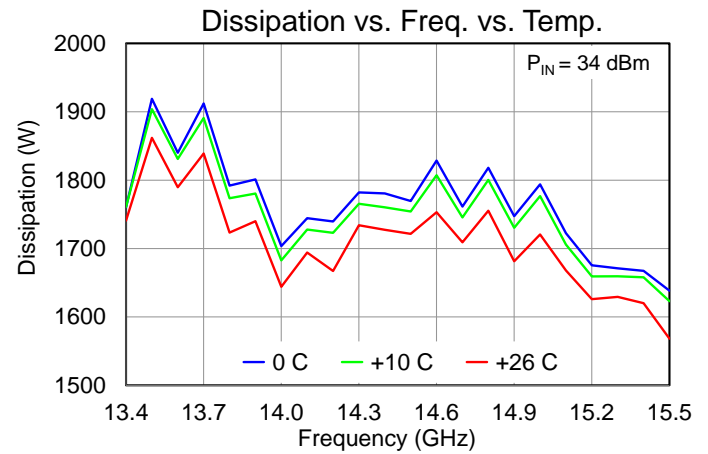
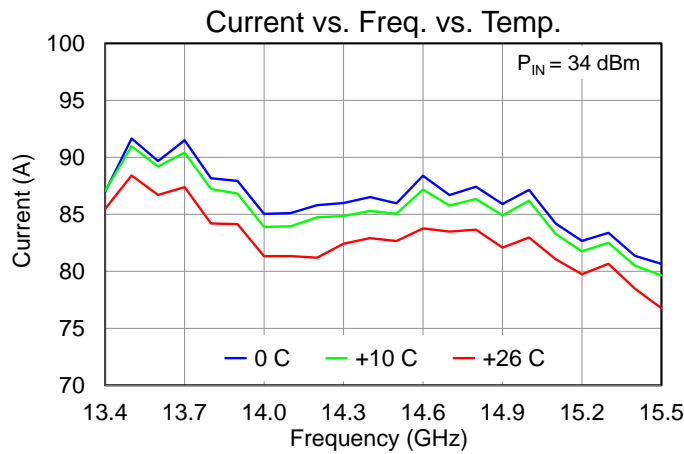
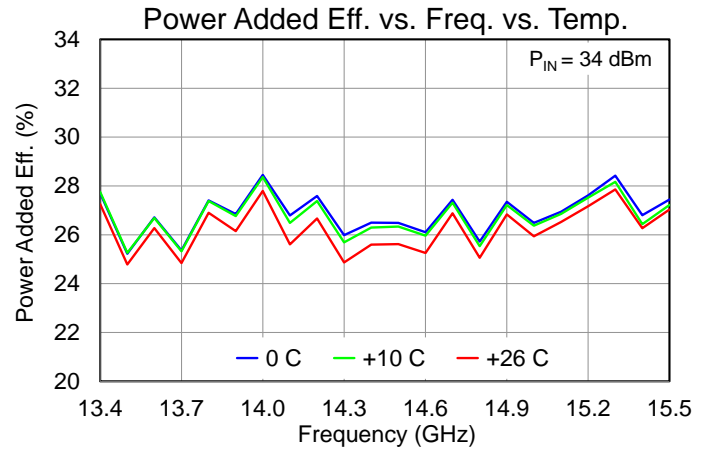
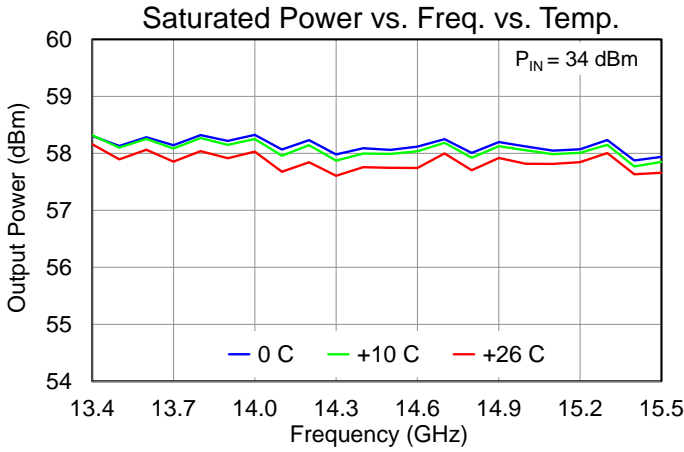

Typical Performance – Large Signal (Pulse)

Test conditions unless otherwise noted: $V_D = 28\text{ V}$, $I_{DQ} = 14.4\text{ A}$, Pulsed $P_{IN} = 34\text{ dBm}$, $T_{COOLANT} = 26\text{ °C}$, $PW = 20\text{ us}$, $DC = 10\%$

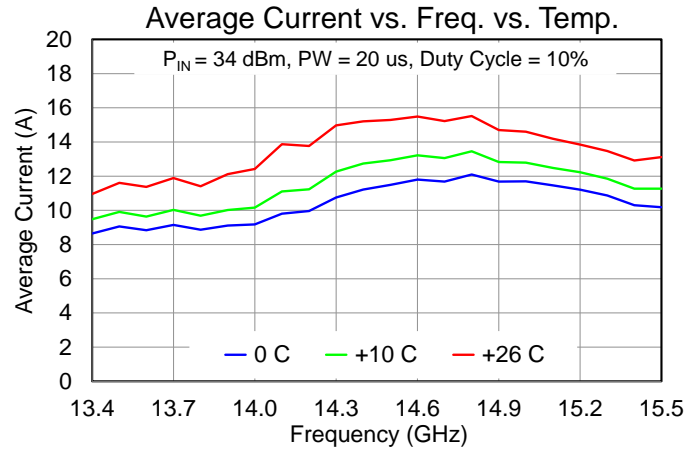
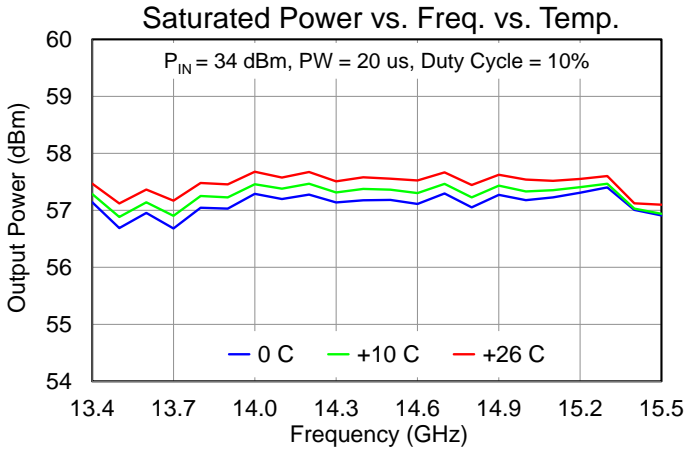

Typical Performance – Linearity, S-Parameters

Test conditions unless otherwise noted: $V_D = 28\text{ V}$, $I_{DQ} = 14.4\text{ A}$, $T_{COOLANT} = 26\text{ }^\circ\text{C}$, CW Operation, 1 MHz Tone Spacing

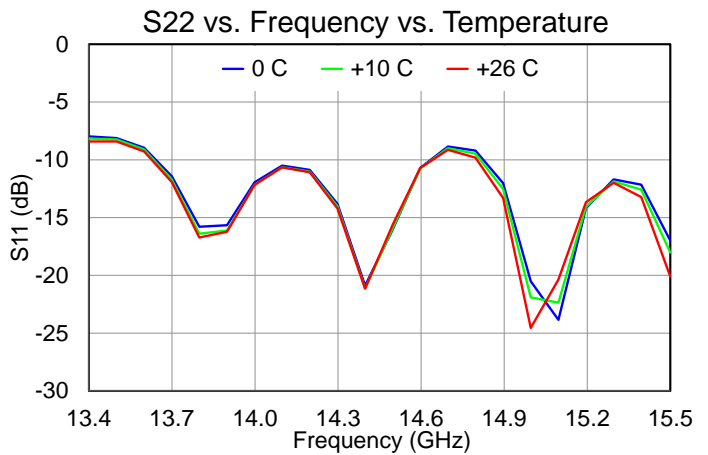
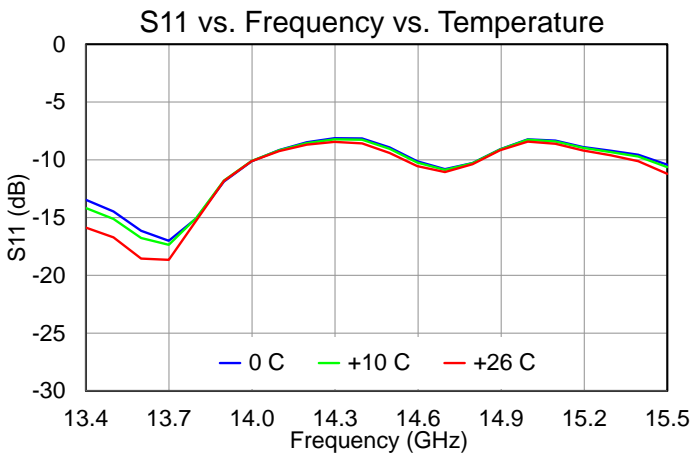
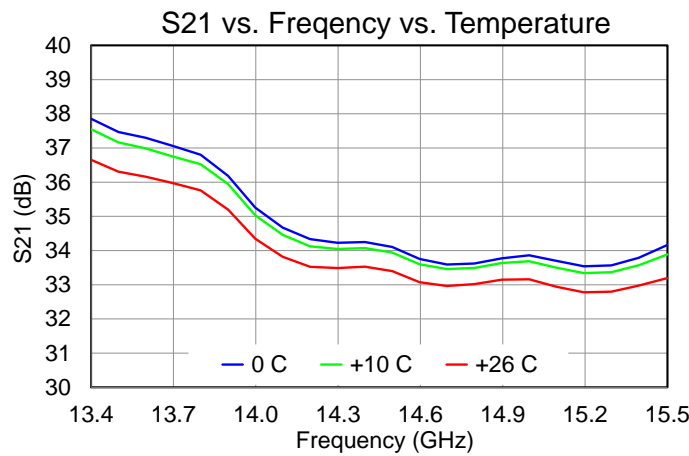
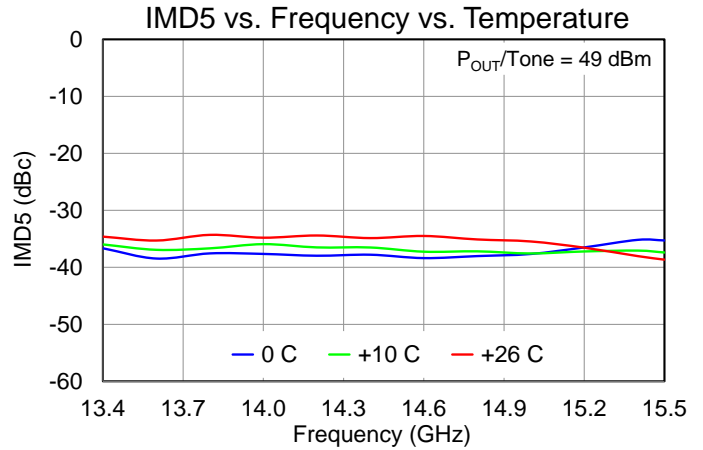
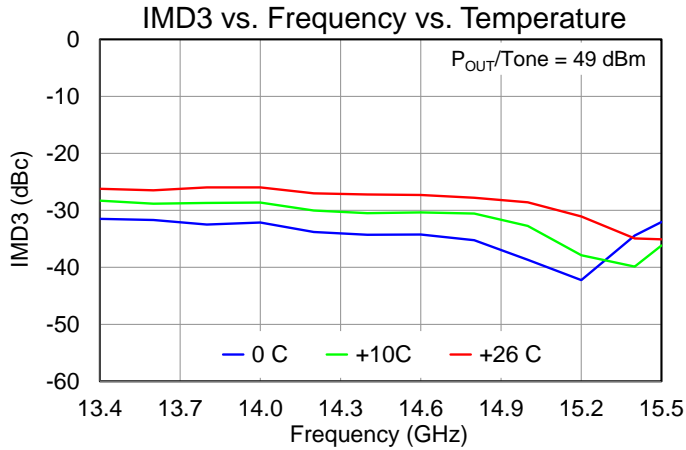

Typical Performance – Reliability

Test conditions unless otherwise noted: $V_D = 28\text{ V}$, $I_{DQ} = 14.4\text{ A}$, $P_{IN} = 34\text{ dBm}$, CW Operation

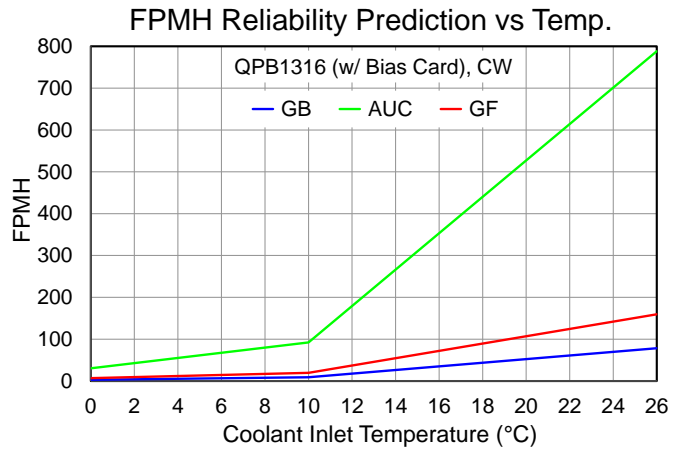
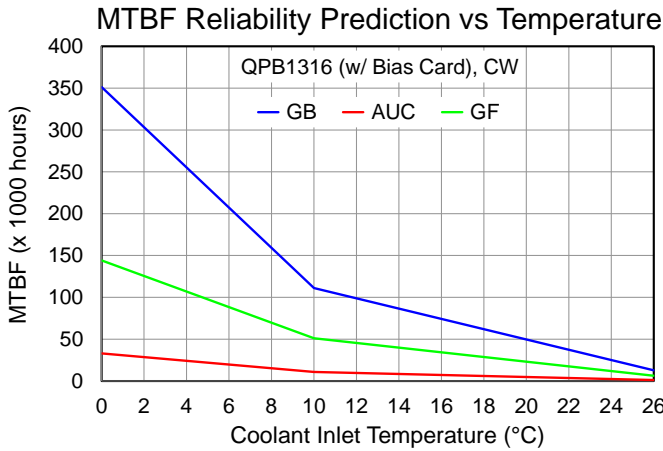

Typical Performance – Heat Exchanger Pressure Drop

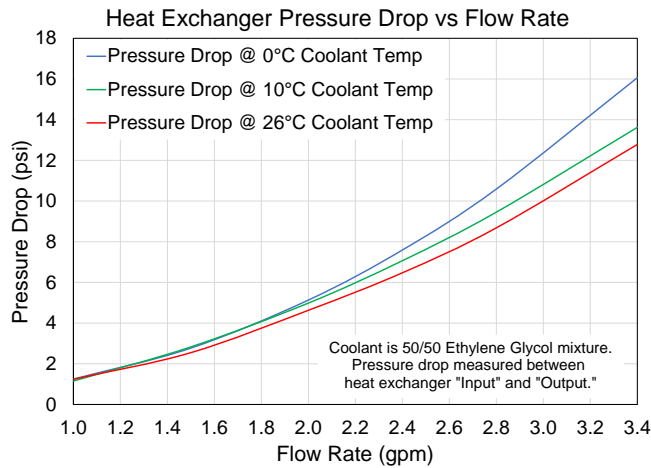

Block Diagram and Description

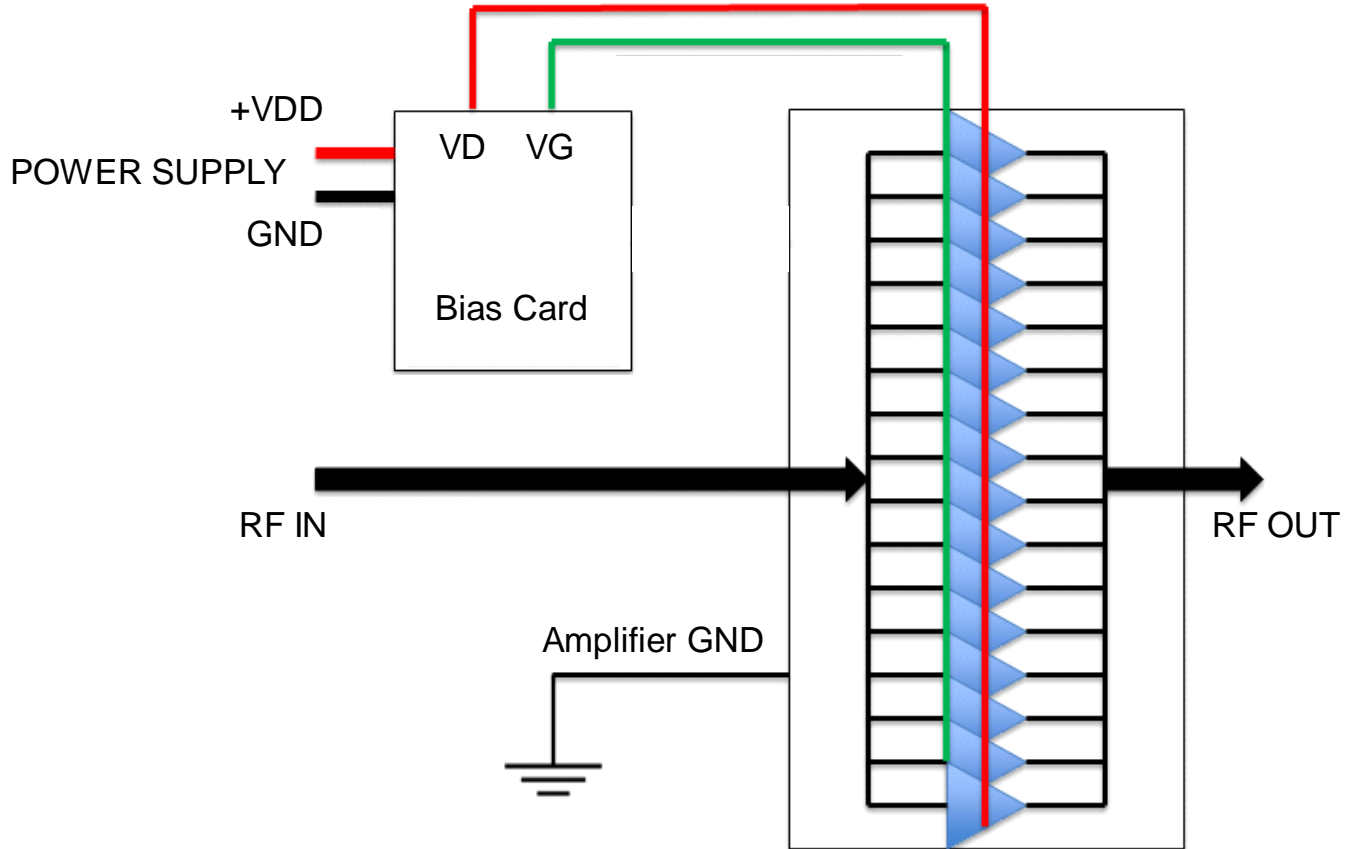

Pin No.	Label	Description
RF In	N/A	SMA (F) Coaxial RF Input.
RF Out	N/A	WR62 Waveguide / UG419/U Flange
Bias Card	P2001, P2003	HARTING connector, 09665527611
POWER SUPPLY +VDD	J2000	MOLEX connector, 76825-0008
POWER SUPPLY GND	J2001	MOLEX connector, 76825-0010

Mechanical Information – Outline Drawing (Spatium™ Unit + GPBC)

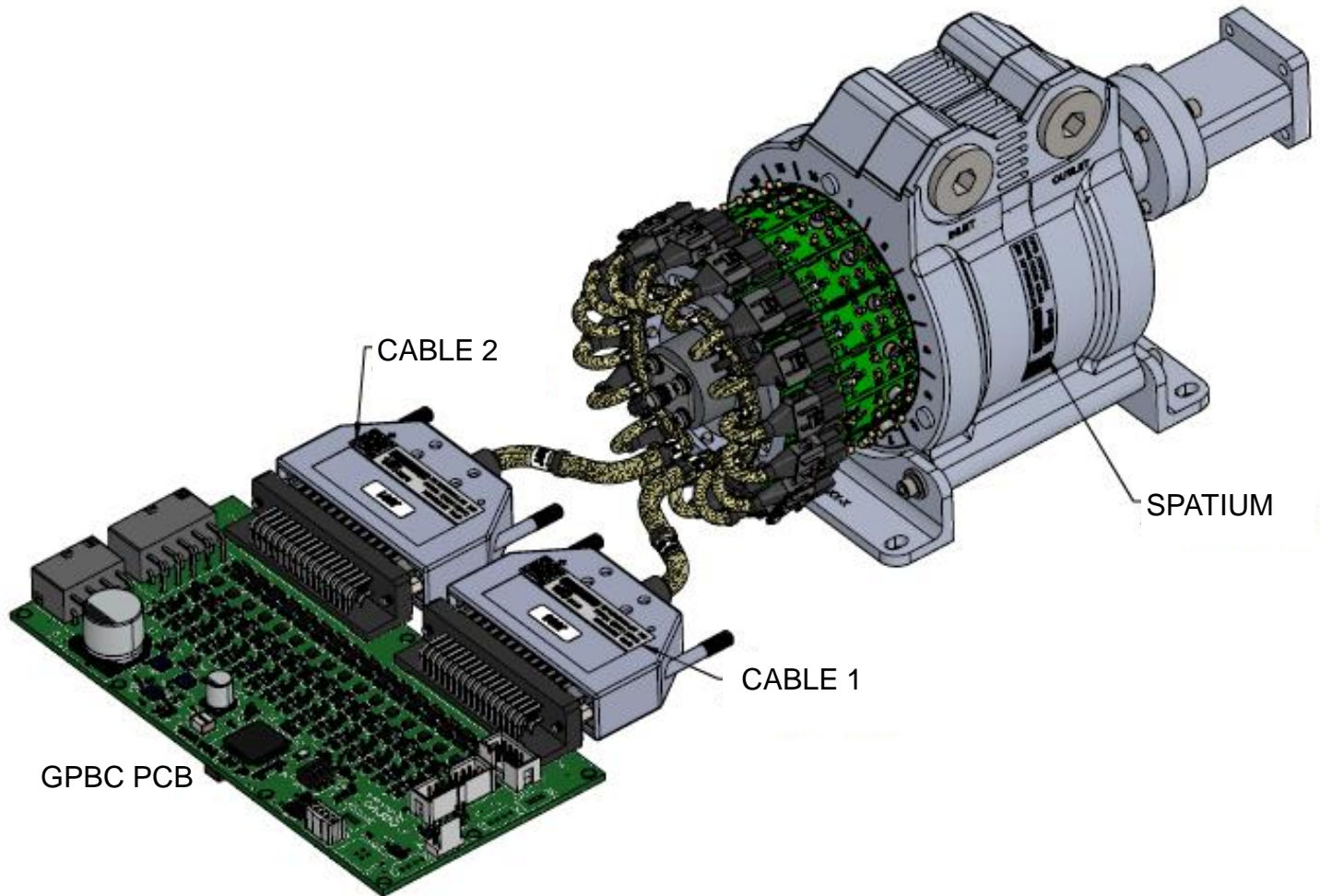

Mechanical Information – Outline Drawing (Spatium™ Unit + GPBC)

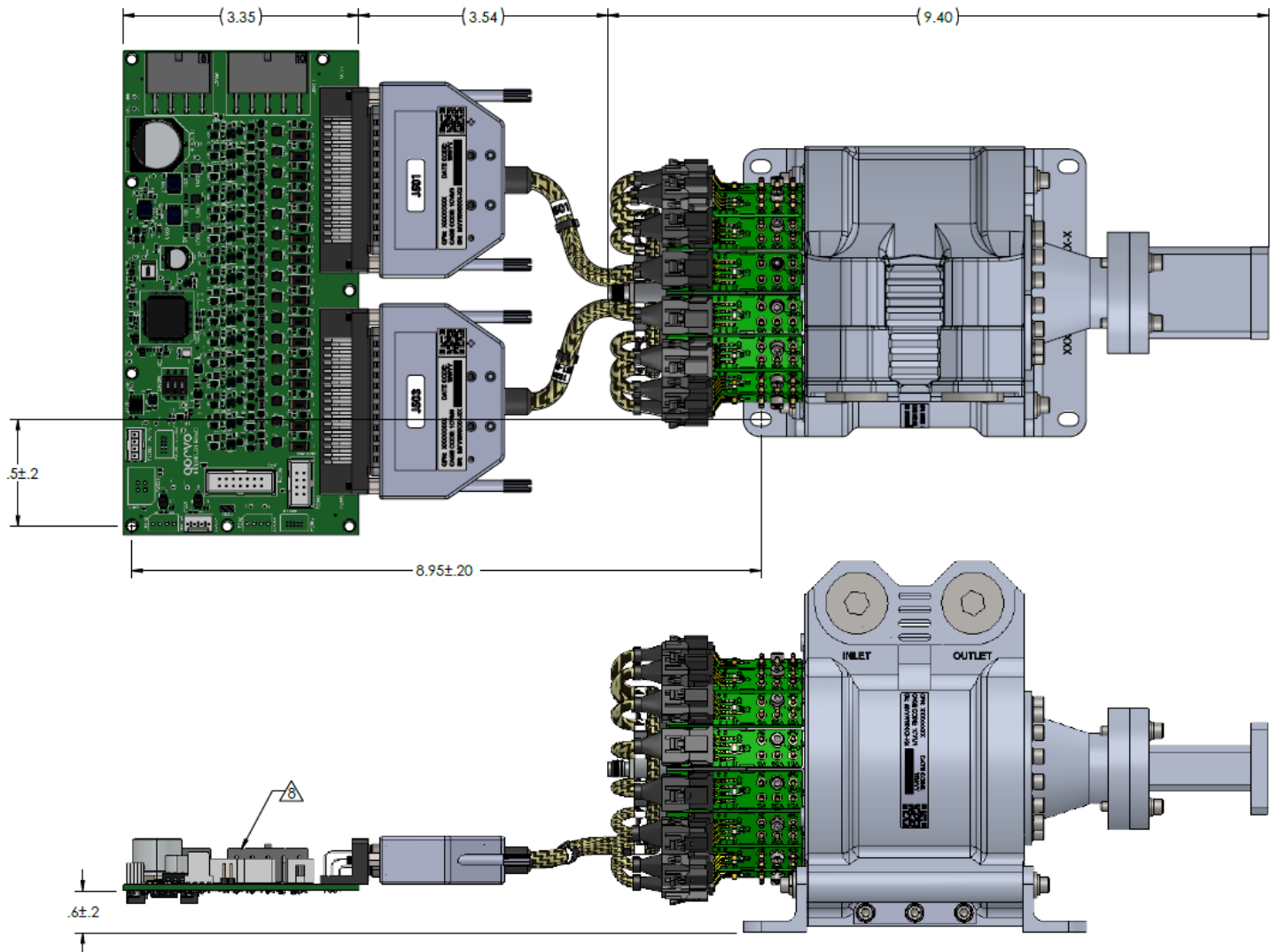

8 AT AMBIENT TEMPERATURES $\geq 50^{\circ}\text{C}$ MINIMUM 200 FPM AIRFLOW SHALL BE PRESENT ON THE INDICATED SURFACE OF THE GPBC. AIRFLOW DIRECTION NON-CRITICAL.

Dimensions are in INCHES

Mechanical Information – Outline Drawing (Spatium™ Unit)

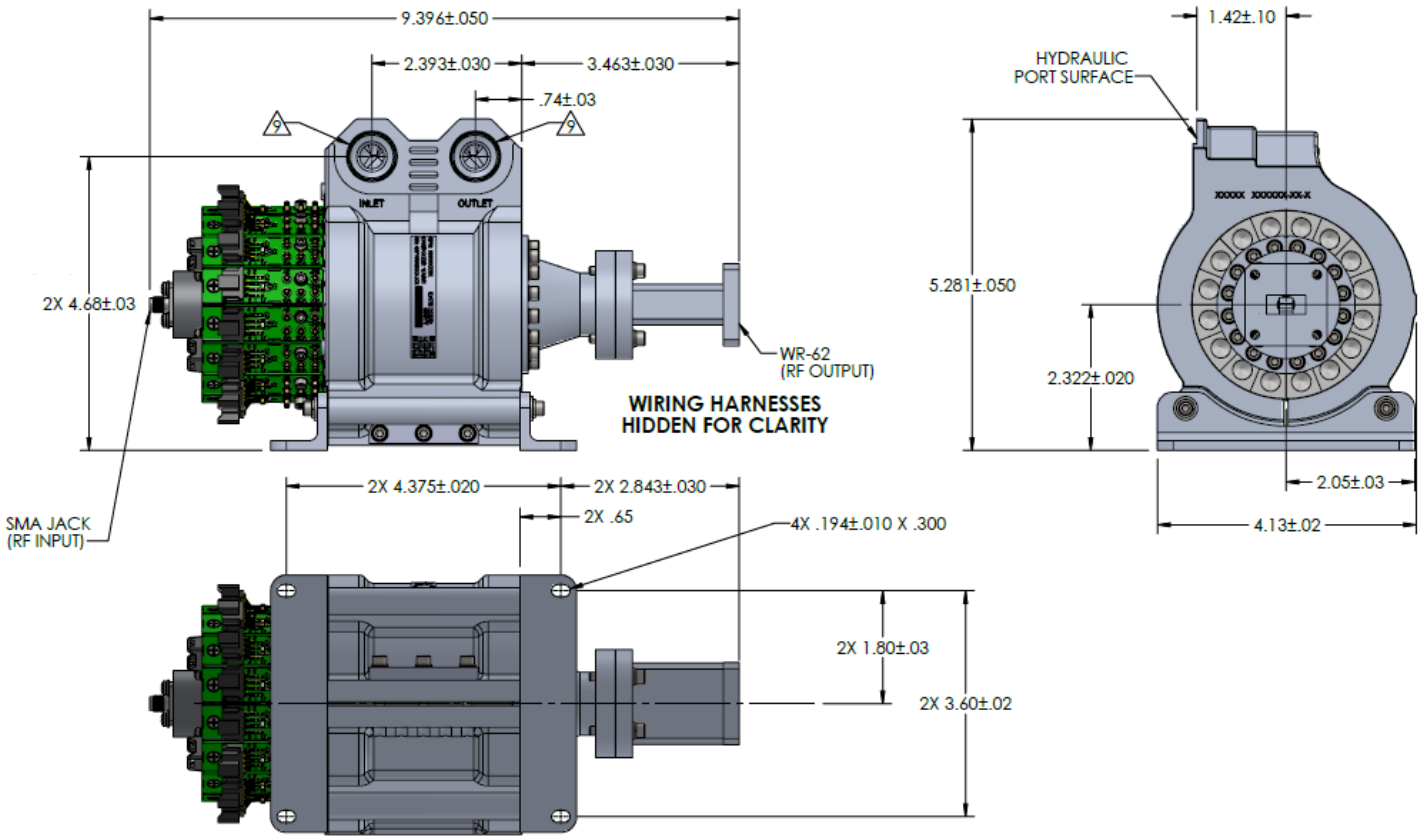

MATING WIRING HARNESSES FOR J2000 (V+) AND J2001 (RTN) SHALL UTILIZE ALL CONTACTS TO ENSURE PROPER LOAD SHARING.

DO NOT CONNECT SPARE PINS.

MAX WEIGHT 12.0 LBS.

DIELECTRIC GREASE SHOULD BE USED BETWEEN WIRING HARNESSES AND ELECTRICAL CONNECTORS.

MARK PG010 (LABEL) PER SPE-000975. THE QPN SHALL BE: 811477-00-XX (XX IS THE REVISION). THE SAME LABEL WITH THE SAME SERIAL NUMBER SHALL BE USED FOR THE MATCHED SET (SPATIUM, 2X CABLES, AND GPBC PCBA). LOCATE LABEL AS SHOWN.

SN: ****
 BATCH I.D.
 WORK WEEK
 CALENDAR YEAR
 MANUFACTURER

QPN: XXXXXXXX DATE CODE: WWYY
 CAGE CODE: 1CVM1
 SN: MYYWWXXX-XX



Dimensions are in INCHES

Mechanical Information – Outline Drawing (GPBC)

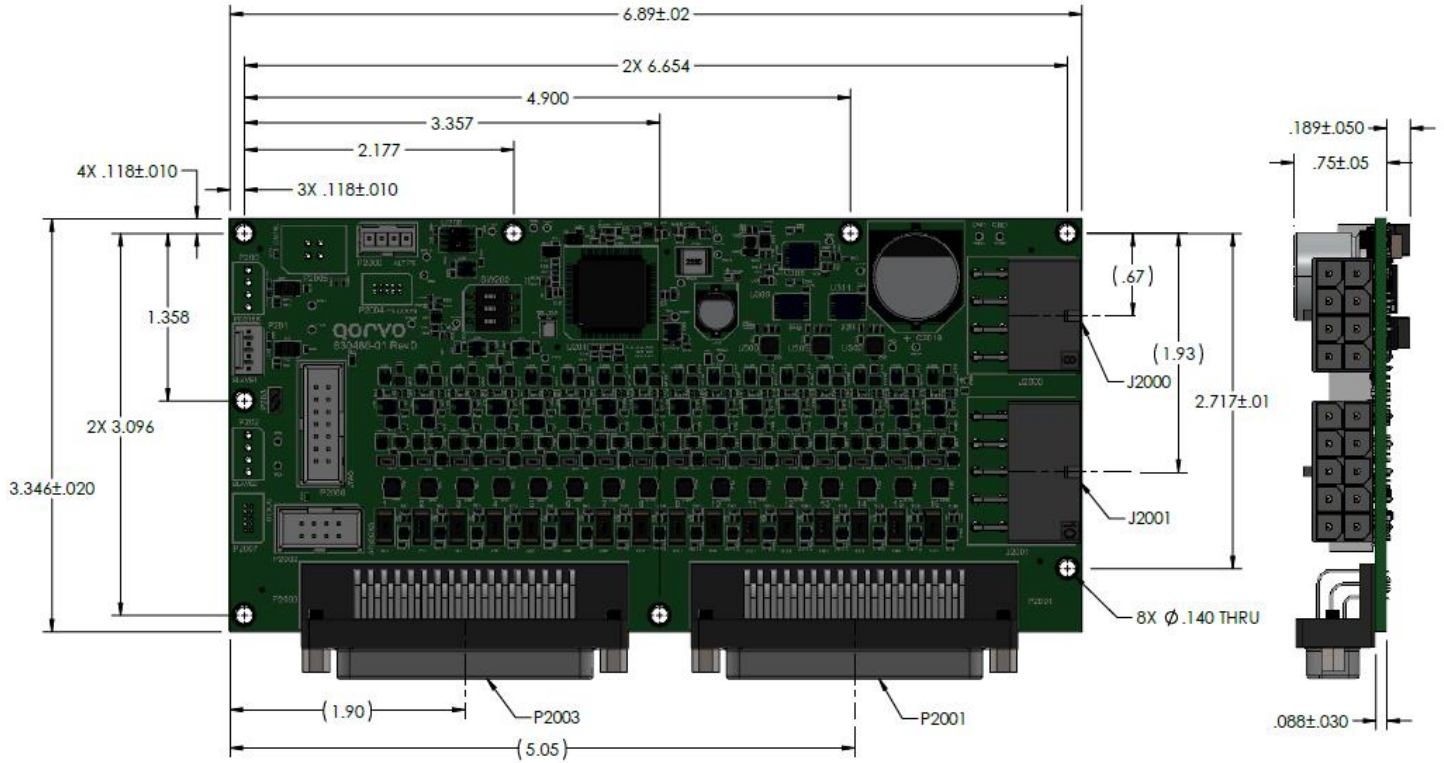

BIAS CARD P2003 (HARTING: 09665527611)			
CABLE J503			
PIN NO	FUNCTION	PIN NO	FUNCTION
1	VG7	26	VD4
2	VD8	27	GND
3	GND	28	VG2
4	VD7	29	VD3
5	GND	30	GND
6	VD6	31	VD2
7	GND	32	GND
8	VD5	33	VD1
9	VG4	34	VG8
10	VD4	35	VD8
11	GND	36	GND
12	VG1	37	VD7
13	VD3	38	GND
14	GND	39	VD6
15	VD2	40	GND
16	GND	41	VD5
17	VD1	42	VG6
18	VD8	43	VD4
19	GND	44	GND
20	VD7	45	VG3
21	GND	46	VD3
22	VD6	47	GND
23	GND	48	VD2
24	VD5	49	GND
25	VG5	50	VD1

BIAS CARD P2001 (HARTING: 09665527611)			
CABLE J501			
PIN NO	FUNCTION	PIN NO	FUNCTION
1	VG15	26	VD12
2	VD16	27	GND
3	GND	28	VG10
4	VD15	29	VD11
5	GND	30	GND
6	VD14	31	VD10
7	GND	32	GND
8	VD13	33	VD9
9	VG12	34	VG16
10	VD12	35	VD16
11	GND	36	GND
12	VG9	37	VD15
13	VD11	38	GND
14	GND	39	VD14
15	VD10	40	GND
16	GND	41	VD13
17	VD9	42	VG14
18	VD16	43	VD12
19	GND	44	GND
20	VD15	45	VG11
21	GND	46	VD11
22	VD14	47	GND
23	GND	48	VD10
24	VD13	49	GND
25	VG13	50	VD9

POWER CONNECTOR MOLEX: 76825-0008	
J2000	
PIN NO	FUNCTION
1	VDD
2	VDD
3	VDD
4	VDD
5	VDD
6	VDD
7	VDD
8	VDD

POWER CONNECTOR MOLEX: 76825-0010	
J2001	
PIN NO	FUNCTION
1	GND
2	GND
3	GND
4	GND
5	GND
6	GND
7	GND
8	GND
9	GND
10	GND

Dimensions are in INCHES

Handling Precautions



Caution!
ESD-Sensitive Device

RF VOLTAGE HAZARD: Contact with RF fields at the output connector can cause burns or electric shock. High levels of RF/Microwave energy may be present when the unit is operating.

HIGH DC CURRENT HAZARD: High levels of DC current are present when the unit is operating.

Contact Information

For the latest specifications, additional product information, worldwide sales and distribution locations:

Web: www.qorvo.com

Tel: 1-844-890-8163

Email: customer.support@qorvo.com

Important Notice

The information contained herein is believed to be reliable; however, Qorvo makes no warranties regarding the information contained herein and assumes no responsibility or liability whatsoever for the use of the information contained herein. All information contained herein is subject to change without notice. Customers should obtain and verify the latest relevant information before placing orders for Qorvo products. The information contained herein or any use of such information does not grant, explicitly or implicitly, to any party any patent rights, licenses, or any other intellectual property rights, whether with regard to such information itself or anything described by such information. **THIS INFORMATION DOES NOT CONSTITUTE A WARRANTY WITH RESPECT TO THE PRODUCTS DESCRIBED HEREIN, AND QORVO HEREBY DISCLAIMS ANY AND ALL WARRANTIES WITH RESPECT TO SUCH PRODUCTS WHETHER EXPRESS OR IMPLIED BY LAW, COURSE OF DEALING, COURSE OF PERFORMANCE, USAGE OF TRADE OR OTHERWISE, INCLUDING THE IMPLIED WARRANTIES OF MERCHANTABILITY AND FITNESS FOR A PARTICULAR PURPOSE.**

Without limiting the generality of the foregoing, Qorvo products are not warranted or authorized for use as critical components in medical, life-saving, or life-sustaining applications, or other applications where a failure would reasonably be expected to cause severe personal injury or death.

Copyright 2024 © Qorvo, Inc. | Qorvo is a registered trademark of Qorvo, Inc.

Looking for pricing, stock, or lifecycle information?

Click below to explore more details on WIN SOURCE:

 [View QPB1316 on WIN SOURCE](#)

 [Qorvo US Inc. Information](#)

Optimize Your Supply Chain with WIN SOURCE Solutions

-  Global Sourcing Solution
-  Obsolete Management
-  Cost Control Management
-  Shortage Management
-  Alternative Solution
-  Excess Inventory Management