

Description

The 74FCT38075S is a low skew, single input to five output, clock buffer. The 74FCT38075S has best in class additive phase Jitter of sub 50 fsec.

Renesas makes many non-PLL and PLL based low output skew devices as well as Zero Delay Buffers to synchronize clocks. Contact us for all of your clocking needs.

Features

- Extremely low RMS Additive Phase Jitter: 50fs
- Low output skew: 50ps
- Packaged in 8-pin SOIC and 8-pin DFN
- Pb (lead) free package
- Low power CMOS technology
- Operating voltages of 1.8V to 3.3V
- Extended temperature range (-40°C to +105°C)

Block Diagram

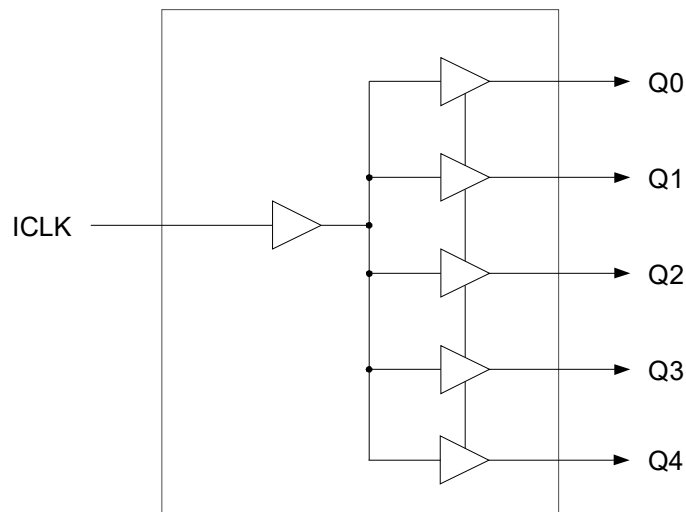

Pin Assignments

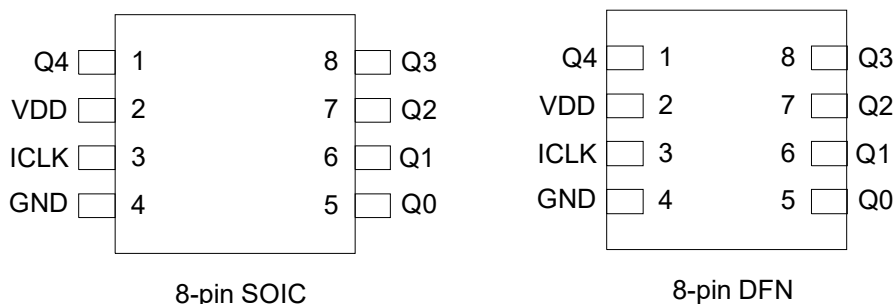

Pin Descriptions

Pin Number	Pin Name	Pin Type	Pin Description
1	Q4	Output	Clock Output 4.
2	VDD	Power	Connect to +1.8V, +2.5 V, or +3.3 V.
3	ICLK	Input	Clock input.
4	GND	Power	Connect to ground.
5	Q0	Output	Clock output 0.
6	Q1	Output	Clock output 1.
7	Q2	Output	Clock Output 2.
8	Q3	Output	Clock Output 3.

External Components

A minimum number of external components are required for proper operation. A decoupling capacitor of 0.01μF should be connected between VDD on pin 2 and GND on pin 4, as close to the device as possible. A 33Ω series terminating resistor may be used on each clock output if the trace is longer than 1 inch.

To achieve the low output skew that the 74FCT38075S is capable of, careful attention must be paid to board layout. Essentially, all five outputs must have identical terminations, identical loads and identical trace geometries. If they do not, the output skew will be degraded. For example, using a 30Ω series termination on one output (with 33Ω on the others) will cause at least 15 ps of skew.

Absolute Maximum Ratings

Stresses above the ratings listed below can cause permanent damage to the 74FCT38075S. These ratings, which are standard values for Renesas commercially rated parts, are stress ratings only. Functional operation of the device at these or any other conditions above those indicated in the operational sections of the specifications is not implied. Exposure to absolute maximum rating conditions for extended periods can affect product reliability. Electrical parameters are guaranteed only over the recommended operating temperature range.

Item	Rating
Supply Voltage, VDD	3.465V
Outputs	-0.5 V to VDD+0.5 V
ICLK	3.465V
Ambient Operating Temperature (extended)	-40° to +105°C
Storage Temperature	-65° to +150°C
Junction Temperature	125°C
Soldering Temperature	260°C

Recommended Operation Conditions

Parameter	Min.	Typ.	Max.	Unit
Ambient Operating Temperature (extended)	-40		+105	°C
Power Supply Voltage (measured in respect to GND)	+1.71		+3.465	V

DC Electrical Characteristics

(VDD = 1.8V, 2.5V, 3.3V)

VDD=1.8V ±5%, Ambient temperature -40° to +105°C, unless stated otherwise

Parameter	Symbol	Conditions	Min.	Typ.	Max.	Units
Operating Voltage	VDD		1.71		1.89	V
Input High Voltage, ICLK	V _{IH}	Note 1	0.7 x VDD		1.89	V
Input Low Voltage, ICLK	V _{IL}	Note 1			0.3 x VDD	V
Output High Voltage	V _{OH}	I _{OH} = -10 mA	1.3			V
Output Low Voltage	V _{OL}	I _{OL} = 10mA			0.35	V
Operating Supply Current	IDD	No load, 135 MHz		13		mA
Nominal Output Impedance	Z _O			17		Ω
Input Capacitance	C _{IN}	ICLK		5		pF

Notes: 1. Nominal switching threshold is VDD/2

VDD=2.5 V ±5%, Ambient temperature -40° to +105°C, unless stated otherwise

Parameter	Symbol	Conditions	Min.	Typ.	Max.	Units
Operating Voltage	VDD		2.375		2.625	V
Input High Voltage, ICLK	V _{IH}	Note 1	0.7 x VDD		2.625	V
Input Low Voltage, ICLK	V _{IL}	Note 1			0.3 x VDD	V
Output High Voltage	V _{OH}	I _{OH} = -16 mA	1.8			V
Output Low Voltage	V _{OL}	I _{OL} = 16 mA			0.5	V
Operating Supply Current	IDD	No load, 135 MHz		18		mA
Nominal Output Impedance	Z _O			17		Ω
Input Capacitance	C _{IN}	ICLK		5		pF

VDD=3.3 V ±5%, Ambient temperature -40° to +105°C, unless stated otherwise

Parameter	Symbol	Conditions	Min.	Typ.	Max.	Units
Operating Voltage	VDD		3.135		3.465	V
Input High Voltage, ICLK	V _{IH}	Note 1	0.7 x VDD		3.465	V
Input Low Voltage, ICLK	V _{IL}	Note 1			0.3 x VDD	V
Output High Voltage	V _{OH}	I _{OH} = -25 mA	2.2			V
Output Low Voltage	V _{OL}	I _{OL} = 25 mA			0.7	V
Operating Supply Current	IDD	No load, 135 MHz		22		mA
Nominal Output Impedance	Z _O			17		Ω
Input Capacitance	C _{IN}	ICLK		5		pF

AC Electrical Characteristics

(VDD = 1.8V, 2.5V, 3.3V)

VDD = 1.8V ±5%, Ambient Temperature -40° to +105°C, unless stated otherwise

Parameter	Symbol	Conditions	Min.	Typ.	Max.	Units
Input Frequency			0		200	MHz
Output Rise Time	t _{OR}	0.36 to 1.44 V, C _L =5 pF		0.6	1.0	ns
Output Fall Time	t _{OF}	1.44 to 0.36 V, C _L =5 pF		0.6	1.0	ns
Start-up Time	t _{START-UP}	Part start-up time for valid outputs after VDD ramp-up			2	ms
Propagation Delay		135MHz, Note 1	1.5	3	4	ns
Buffer Additive Phase Jitter, RMS		125MHz, Integration Range: 12kHz-20MHz			0.05	ps
Output to Output Skew		Rising edges at VDD/2, Note 2		50	65	ps
Device to Device Skew		Rising edges at VDD/2			500	ps

VDD = 2.5 V ±5%, Ambient Temperature -40° to +105°C, unless stated otherwise

Parameter	Symbol	Conditions	Min.	Typ.	Max.	Units
Input Frequency			0		200	MHz
Output Rise Time	t _{OR}	0.5 to 2.0 V, C _L =5 pF		0.6	1.0	ns
Output Fall Time	t _{OF}	2.0 to 0.5 V, C _L =5 pF		0.6	1.0	ns
Start-up Time	t _{START-UP}	Part start-up time for valid outputs after VDD ramp-up			2	ms
Propagation Delay		135MHz, Note 1	1.8	2.5	4.5	ns
Buffer Additive Phase Jitter, RMS		125MHz, Integration Range: 12kHz-20MHz			0.05	ps
Output to Output Skew		Rising edges at VDD/2, Note 2		50	65	ps
Device to Device Skew		Rising edges at VDD/2			500	ps

VDD = 3.3 V ±5%, Ambient Temperature -40° to +105°C, unless stated otherwise

Parameter	Symbol	Conditions	Min.	Typ.	Max.	Units
Input Frequency			0		200	MHz
Output Rise Time	t _{OR}	0.66 to 2.64 V, C _L =5 pF		0.6	1.0	ns
Output Fall Time	t _{OF}	2.64 to 0.66 V, C _L =5 pF		0.6	1.0	ns
Start-up Time	t _{START-UP}	Part start-up time for valid outputs after VDD ramp-up			2	ms
Propagation Delay		135MHz, Note 1	1.5	2.5	4	ns
Buffer Additive Phase Jitter, RMS		125MHz, Integration Range: 12kHz-20MHz			0.05	ps
Output to Output Skew		Rising edges at VDD/2, Note 2		50	65	ps
Device to Device Skew		Rising edges at VDD/2			500	ps

Notes:

1. With rail to rail input clock
2. Between any 2 outputs with equal loading.
3. Duty cycle on outputs will match incoming clock duty cycle. Consult Renesas for tight duty cycle clock generators.

Test Load and Circuit

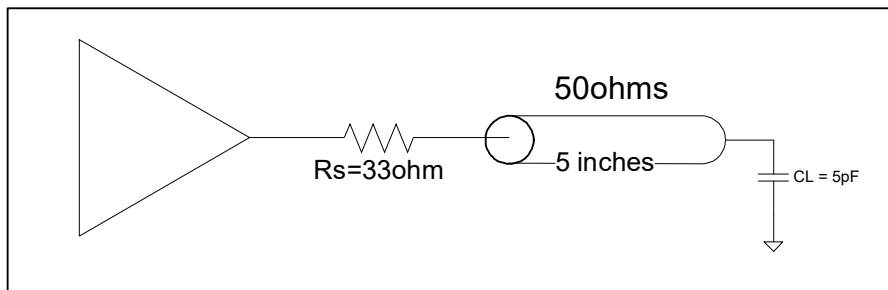

Thermal Characteristics

8SOIC

Parameter	Symbol	Conditions	Min.	Typ.	Max.	Unit
Thermal Resistance Junction to Ambient	θ_{JA}	Still air		150		°C/W
	θ_{JA}	1 m/s air flow		140		°C/W
	θ_{JA}	3 m/s air flow		120		°C/W
Thermal Resistance Junction to Case	θ_{JC}			40		°C/W

8DFN

Parameter	Symbol	Conditions	Min.	Typ.	Max.	Unit
Thermal Resistance Junction to Ambient	θ_{JA}	Still air		140.7		°C/W
	θ_{JA}	1 m/s air flow		136.5		°C/W
	θ_{JA}	2 m/s air flow		133.3		°C/W
	θ_{JA}	3 m/s air flow		131.4		°C/W
Thermal Resistance Junction to Board	θ_{JB}			93.8		°C/W
Thermal Resistance Junction to Case	θ_{JC}			64.5		°C/W

Marking Diagrams

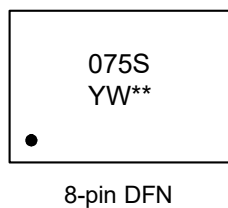
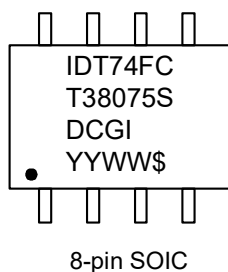

Notes:

1. “**” is the lot number.
2. “YYWW” or “YW” are the last digits of the year and week that the part was assembled.
- 3 “G” denotes RoHS compliant package.
4. “\$” denotes mark code.
5. “I” denotes extended temperature range device.

Ordering Information

Part / Order Number	Marking	Shipping Packaging	Package	Temperature
74FCT38075SDCGI	see page 6	Tubes	8-pin SOIC	-40° to +105°C
74FCT38075SDCGI8		Tape and Reel	8-pin SOIC	-40° to +105°C
74FCT38075SCMGI		Cut Tape	8-pin DFN	-40° to +105°C
74FCT38075SCMGI8		Tape and Reel	8-pin DFN	-40° to +105°C

“G” after the two-letter package code denotes Pb-Free configuration, RoHS compliant.

Revision History

Revision	Date	Description
1.01	Jun 11, 2025	<ul style="list-style-type: none"> Added Thermal Characteristics for the 8DFN package. Added package links to Ordering Information.
1.00	Mar 18, 2015	Initial release.

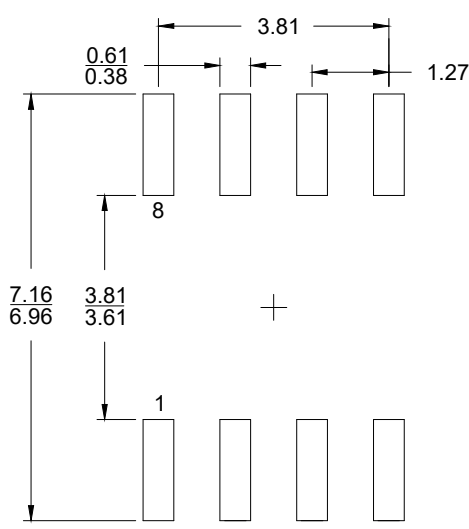
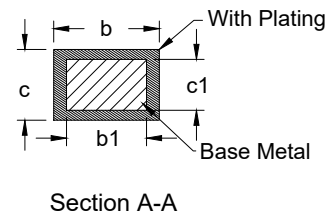
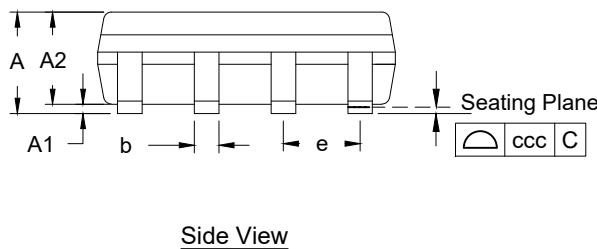
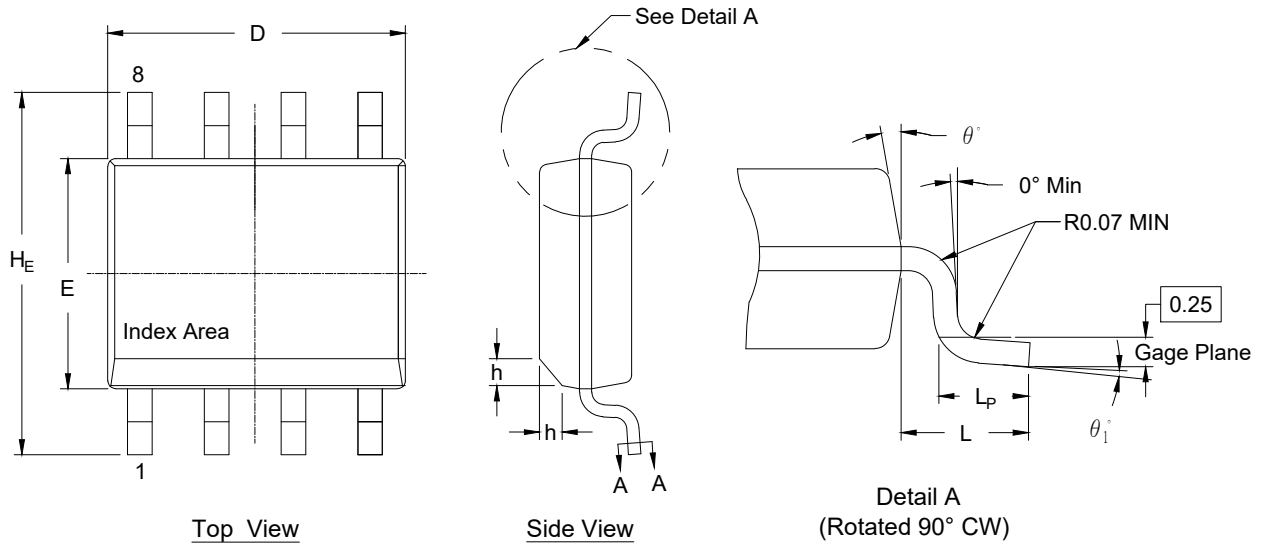

SYMBOLS	MIN.	NOM.	MAX.
A	—	—	1.75
A1	0.10	—	0.25
A2	1.25	—	—
b	0.31	—	0.51
D	4.80	4.90	5.00
HE	5.80	6.00	6.20
E	3.80	3.90	4.00
e	1.27 BSC		
ccc	0.10		
Lp	0.40	—	1.27
L	(1.00)		
θ	5°	—	15°
θ _i	0°	—	8°
h	0.25	—	0.50
b	0.31	—	0.51
b1	0.28	—	0.48
c	0.10	—	0.25
c1	0.10	—	0.25

UNIT : MM

NOTES:

1. JEDEC compatible.
2. All dimensions are in mm and angles are in degrees.
3. Use ± 0.05 mm for the non-toleranced dimensions.
4. Foot length is measured at gauge plane 0.25 mm above seating plane.

RECOMMENDED LAND PATTERN
(PCB Top View, SMD Design)

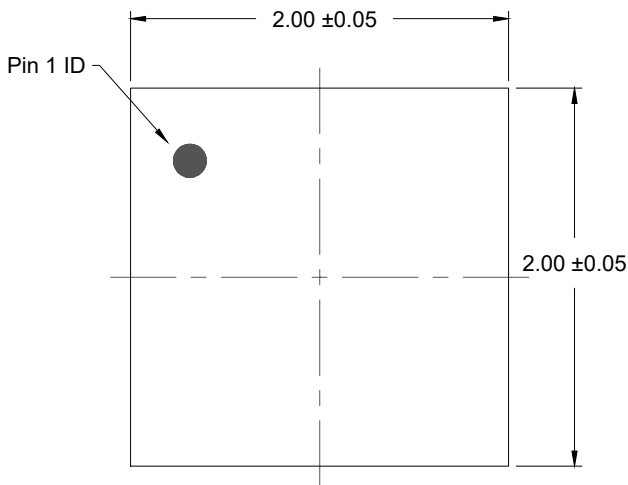

TOP VIEW

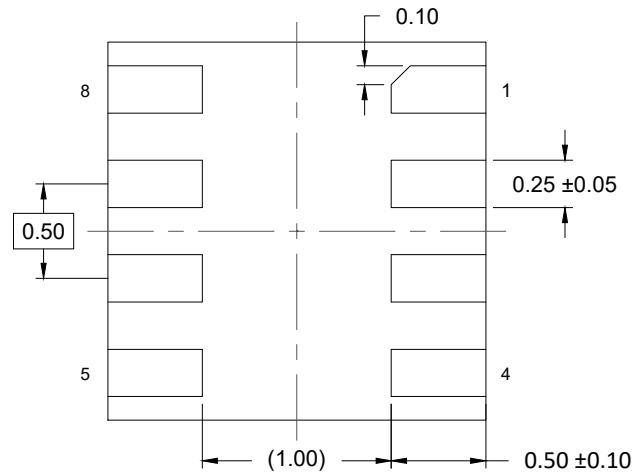

BOTTOM VIEW

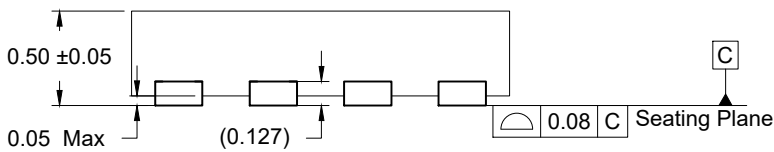

SIDE VIEW

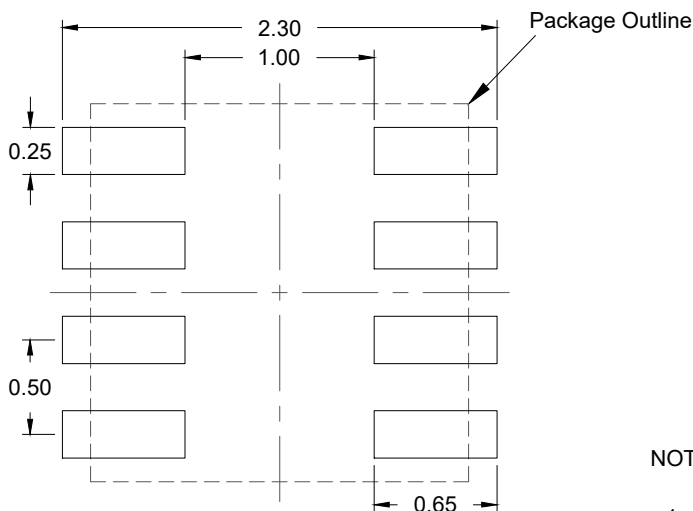

RECOMMENDED LAND PATTERN
(PCB Top View, NSMD Design)

NOTES:

1. JEDEC compatible.
2. All dimensions are in mm and angles are in degrees.
3. Use ± 0.05 mm for the non-toleranced dimensions.
4. Numbers in () are for references only.

IMPORTANT NOTICE AND DISCLAIMER

RENESAS ELECTRONICS CORPORATION AND ITS SUBSIDIARIES (“RENESAS”) PROVIDES TECHNICAL SPECIFICATIONS AND RELIABILITY DATA (INCLUDING DATASHEETS), DESIGN RESOURCES (INCLUDING REFERENCE DESIGNS), APPLICATION OR OTHER DESIGN ADVICE, WEB TOOLS, SAFETY INFORMATION, AND OTHER RESOURCES “AS IS” AND WITH ALL FAULTS, AND DISCLAIMS ALL WARRANTIES, EXPRESS OR IMPLIED, INCLUDING, WITHOUT LIMITATION, ANY IMPLIED WARRANTIES OF MERCHANTABILITY, FITNESS FOR A PARTICULAR PURPOSE, OR NON-INFRINGEMENT OF THIRD-PARTY INTELLECTUAL PROPERTY RIGHTS.

These resources are intended for developers who are designing with Renesas products. You are solely responsible for (1) selecting the appropriate products for your application, (2) designing, validating, and testing your application, and (3) ensuring your application meets applicable standards, and any other safety, security, or other requirements. These resources are subject to change without notice. Renesas grants you permission to use these resources only to develop an application that uses Renesas products. Other reproduction or use of these resources is strictly prohibited. No license is granted to any other Renesas intellectual property or to any third-party intellectual property. Renesas disclaims responsibility for, and you will fully indemnify Renesas and its representatives against, any claims, damages, costs, losses, or liabilities arising from your use of these resources. Renesas' products are provided only subject to Renesas' Terms and Conditions of Sale or other applicable terms agreed to in writing. No use of any Renesas resources expands or otherwise alters any applicable warranties or warranty disclaimers for these products.

(Disclaimer Rev.1.01)

Corporate Headquarters

TOYOSU FORESIA, 3-2-24 Toyosu,
Koto-ku, Tokyo 135-0061, Japan
www.renesas.com

Trademarks

Renesas and the Renesas logo are trademarks of Renesas Electronics Corporation. All trademarks and registered trademarks are the property of their respective owners.

Contact Information

For further information on a product, technology, the most up-to-date version of a document, or your nearest sales office, please visit www.renesas.com/contact-us/.

Looking for pricing, stock, or lifecycle information?

Click below to explore more details on WIN SOURCE:

- ⊖ [View 74FCT38075SCMG18 on WIN SOURCE](#)
- ⊖ [Renesas Electronics America](#) Information

Optimize Your Supply Chain with WIN SOURCE Solutions

- ✓ Global Sourcing Solution
- ✓ Obsolete Management
- ✓ Cost Control Management
- ✓ Shortage Management
- ✓ Alternative Solution
- ✓ Excess Inventory Management