

Connector for SD Memory Card

SCDA Series



Compact low-profile type with highly reliable contact structure.

For SD Memory Card

For microSD™ Card

For SIM Card 8pins

For Memory Stick Micro™

Combine Type

For W-SIM



Typical Specifications

Items		Specifications	
Structure	Applicable media	SD Memory Card/ MultiMediaCard™	
	Mounting type	Surface mounting type	
	Mounting style	Standard mount/Reverse mount	
	Media ejection structure	Push-push type	
Performance	Operating temperature range	-25°C to +60°C	
	Voltage proof	100V AC 1minute	
	Insulation resistance (Initial)	1,000MΩ min.	
	Contact resistance (Initial)	Connector contacts	100mΩ max.
		Detection switch	500mΩ max.
Insertion and removal cycle		10,000cycles	

Product Line

Media ejection structure	Mounting style	Features	Stand-off (mm)	Packing system	Product No.	Drawing No.
Push-push type	Standard mount	Inner tail, card eject stroke 5mm	0	Taping	SCDA9A0400	1
		Inner tail, card eject stroke 8mm			SCDA8A0201	2
		Outer tail, card eject stroke 8mm	1.5		SCDA7A0101	3
	Reverse mount	Outer tail	1.8		SCDA7A0200	4
			0		SCDA7A1201	5
			1.8		SCDAAA0100	6
					SCDAAA0601	7

Packing Specifications

Taping

Unit:mm

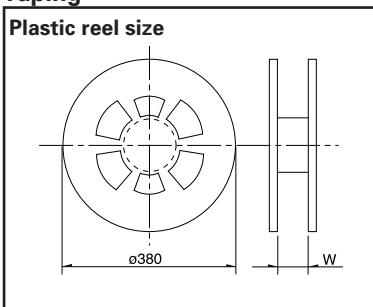

Product No.	Number of packages (pcs.)			Reel width W (mm)	Tape width (mm)	Export package measurements (mm)
	1 reel	1 case /Japan	1 case /export packing			
SCDA7A0101	400	800	1,600	45.5	44	403 × 403 × 249
SCDA7A0200	250	500	1,000			
SCDA7A1201	300	600	1,200			
SCDA8A0201	400	800	1,600			
SCDA9A0400						
SCDAAA0100	500	1,000	2,000			
SCDAAA0601	300	600	1,200			

Note

Please place purchase orders per minimum order unit N (integer).

Refer to P.558 for soldering conditions.



For SD Memory Card

For microSD™ Card

For SIM Card 8pins

For Memory Stick Micro™

Combine Type

For W-SIM



Automotive Use

Dimensions

Standard mount (Inner tail)

Unit:mm

No.	Style	PC board mounting hole dimensions (Viewed from the mounting face side)
1	<p>Stand-off 0mm Card eject stroke 5mm</p>	<p>Recommended P.C.B layout (Mounting face side)</p> <ul style="list-style-type: none"> LAND NO PART AREA NO PATTERN AREA NO PATTERN EXPOSE AREA
2	<p>Stand-off 0mm Card eject stroke 8mm</p>	<p>Center line of positioning bosses</p> <ul style="list-style-type: none"> Land area Pattern prohibition area

Dimensions Reverse mount











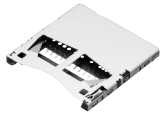



Unit:mm

- For SD Memory Card
- For microSD™ Card
- For SIM Card 8pins
- For Memory Stick Micro™
- Combine Type
- For W-SIM

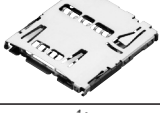
No.	Style	PC board mounting hole dimensions (Viewed from the mounting face side)																														
6	<p>Stand-off 0mm Card eject stroke 8mm</p> <p style="text-align: center;">Connector center Card center</p>	<p style="text-align: center;"> No pattern area Land area No parts area </p>																														
	<p style="text-align: center;">Circuit Diagram for Detect Switch</p>	<table border="1" style="width: 100%; border-collapse: collapse;"> <thead> <tr> <th>Pin No.</th> <th>Name</th> <th>Discription</th> </tr> </thead> <tbody> <tr><td>1</td><td>CD/DAT3</td><td>Card Detect / Date Line</td></tr> <tr><td>2</td><td>CMD</td><td>Command / Response</td></tr> <tr><td>3</td><td>V_{SSI}</td><td>Supply voltage ground</td></tr> <tr><td>4</td><td>V_{DD}</td><td>Supply voltage</td></tr> <tr><td>5</td><td>CLK</td><td>Clock</td></tr> <tr><td>6</td><td>V_{SS2}</td><td>Supply voltage ground</td></tr> <tr><td>7</td><td>DAT0</td><td>Date Line</td></tr> <tr><td>8</td><td>DAT1</td><td>Date Line</td></tr> <tr><td>9</td><td>DAT2</td><td>Date Line</td></tr> </tbody> </table>	Pin No.	Name	Discription	1	CD/DAT3	Card Detect / Date Line	2	CMD	Command / Response	3	V _{SSI}	Supply voltage ground	4	V _{DD}	Supply voltage	5	CLK	Clock	6	V _{SS2}	Supply voltage ground	7	DAT0	Date Line	8	DAT1	Date Line	9	DAT2	Date Line
Pin No.	Name	Discription																														
1	CD/DAT3	Card Detect / Date Line																														
2	CMD	Command / Response																														
3	V _{SSI}	Supply voltage ground																														
4	V _{DD}	Supply voltage																														
5	CLK	Clock																														
6	V _{SS2}	Supply voltage ground																														
7	DAT0	Date Line																														
8	DAT1	Date Line																														
9	DAT2	Date Line																														
7	<p>Stand-off 1.8mm Card eject stroke 8mm</p> <p style="text-align: center;">Connector center Card center</p>	<p style="text-align: center;"> No parts area Land area Parts mount area (Parts height is 1.5max) Parts mount area (Parts height is 1.2max) </p>																														
	<p style="text-align: center;">Circuit Diagram for Detect Switch</p>	<table border="1" style="width: 100%; border-collapse: collapse;"> <thead> <tr> <th>Pin No.</th> <th>Name</th> <th>Discription</th> </tr> </thead> <tbody> <tr><td>1</td><td>CD/DAT3</td><td>Card Detect / Date Line</td></tr> <tr><td>2</td><td>CMD</td><td>Command / Response</td></tr> <tr><td>3</td><td>V_{SSI}</td><td>Supply voltage ground</td></tr> <tr><td>4</td><td>V_{DD}</td><td>Supply voltage</td></tr> <tr><td>5</td><td>CLK</td><td>Clock</td></tr> <tr><td>6</td><td>V_{SS2}</td><td>Supply voltage ground</td></tr> <tr><td>7</td><td>DAT0</td><td>Date Line</td></tr> <tr><td>8</td><td>DAT1</td><td>Date Line</td></tr> <tr><td>9</td><td>DAT2</td><td>Date Line</td></tr> </tbody> </table>	Pin No.	Name	Discription	1	CD/DAT3	Card Detect / Date Line	2	CMD	Command / Response	3	V _{SSI}	Supply voltage ground	4	V _{DD}	Supply voltage	5	CLK	Clock	6	V _{SS2}	Supply voltage ground	7	DAT0	Date Line	8	DAT1	Date Line	9	DAT2	Date Line
Pin No.	Name	Discription																														
1	CD/DAT3	Card Detect / Date Line																														
2	CMD	Command / Response																														
3	V _{SSI}	Supply voltage ground																														
4	V _{DD}	Supply voltage																														
5	CLK	Clock																														
6	V _{SS2}	Supply voltage ground																														
7	DAT0	Date Line																														
8	DAT1	Date Line																														
9	DAT2	Date Line																														

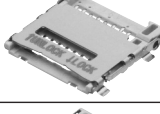
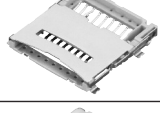

List of Varieties

Applicable media	Product No.	Photo	Media ejection structure	Mounting style	Features	Stand-off (mm)	Auto motive use	Page	
For SD Memory Card For microSD™ Card For SIM Card 8pins For Memory Stick Micro™ Combine Type For W-SIM	SCDA9A0400		Push-push type	Standard mount	Inner tail Card eject stroke 5mm	0	—	527	
	SCDA8A0201				Inner tail Card eject stroke 8mm		○		
	SCDA7A0101				Card eject stroke 8mm	1.5	—		
	SCDA7A0200					1.8			
	SCDA7A1201			Push-push type	Reverse mount	Outer tail	0		—
	SCDAAA0100						1.8		—
	SCDAAA0601						0		—
	SCDAAA0601						1.8		—
microSD™ Card	SCHA4B0100		Manual insertion/removal	Standard mount	With switch	0	○	532	
	SCHA4B0400				With switches and fly-out protection.		—		
	SCHA5B0200			Reverse mount	With switch		○		
	SCHB1A0205		Manual insertion/removal	Standard mount	Hinge cover type Without switch	0	—	535	
	SCHB1B0100				Hinge cover type With switch				
	SCHD1A0101				Header type				537
	SCHD3A0100			Adapter	—			539	
	SCHH1D0100								

Note

○marks in "Available for automotive use" indicate that some of the series products can work at the operating temperature range from -40°C to +85°C.

Note

Please place purchase orders per minimum order unit N (integer).

Soldering Conditions

Example of Reflow Soldering Condition (Reference)

1. Heating method: Double heating method with infrared heater.
2. Temperature measurement: Thermocouple 0.1 to 0.2 ϕ CA (K) or CC (T) at soldering portion.
3. Temperature profile

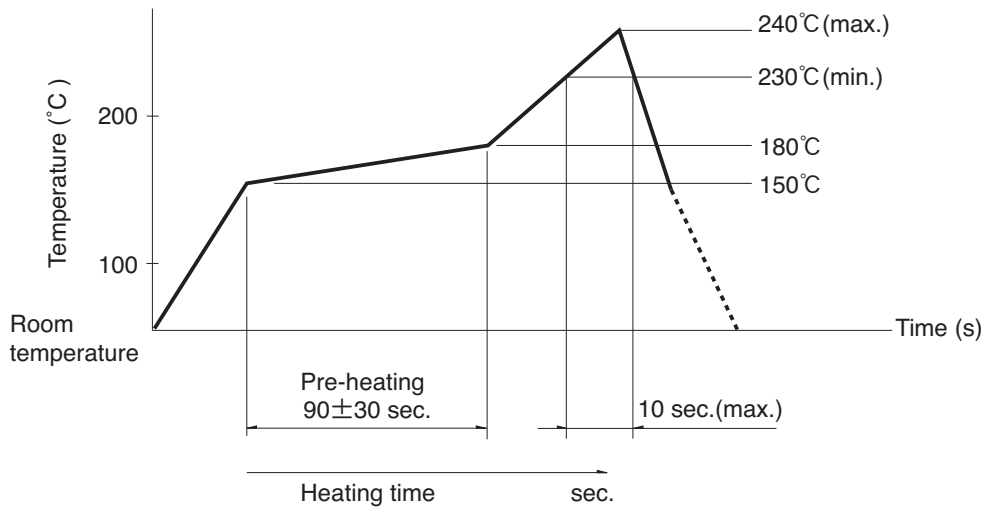

Please refer to each product's specification sheet to confirm temperature profile.

Cautions for using this product

1.Connector handling precautions

- (1) Safeguard the connector assembly against flux penetration from its top side.
- (2) This product is designed on the assumption that they will not be washed after soldering. If you wash it, it may cause deterioration of mechanically and electrically.

If washing is necessary, please make contact with us beforehand.

2. When soldering terminals, there is a danger that load placed on the terminals may cause rattle, deformation or electrical degradation to occur depending on the conditions.

Caution is therefore required.

3. When soldering, do not use water soluble flux because this may corrode the product.

4. regarding the setting of reflow conditions, please confirm them with the actual mass production conditions.

5. As P.W.B. warping may alter characteristics, please take this into consideration when designing pattern and layout.

6. Please do not solder at the ejector pushing position.

7. To prevent contact disturbance by the sulfuration or oxidation of the contact and terminal, and deterioration of solder ability by thin film on the terminal, please note following.

- Storage in the atmosphere of high temperature at 60 degrees or more, high humidity, corrosive gases such as sulfur or chlorine gas, and excessive piling up of the carton boxes shall be avoided.
- Connectors shall be stored as the package not opened and in the normal temperature and normal humidity, and the connectors shall be used preferably within 3 months, at least within 6 months.
- When the connectors are stored after opening the package, the connectors shall be sealed with a polyethylene bag etc. and stored in dark and cool place, avoiding direct sunlight. Bag etc. and stored in dark and cool place, avoiding direct sunlight. The connectors shall be used as soon as possible.

8. Don't push or hold down the metal cover of the connector, otherwise there is a possibility that the card would not be ejected or influences to other function.

9. Please attention following items to prevent connector from miss operation, such as bounding caused by ON/OFF switching and chattering by vibration.

- Repeated reading/writing.
- Establish delay time-recommended 400msec min.
- Establish CR accumulation circuit.

10. This product does not operate normally when the card which does not conform to the specification is used occasionally.

For
SD Memory
Card

For
microSD™
Card

For
SIM Card
8pins



For
Memory
Stick Micro™

Combine Type

For
W-SIM

Looking for pricing, stock, or lifecycle information?

Click below to explore more details on WIN SOURCE:

-  [View SCDA00100 on WIN SOURCE](#)
-  [Alps Alpine Information](#)

Optimize Your Supply Chain with WIN SOURCE Solutions

-  Global Sourcing Solution
-  Obsolete Management
-  Cost Control Management
-  Shortage Management
-  Alternative Solution
-  Excess Inventory Management