

RACM30-K/277 Series \diamond AC/DC Power Supply

30W \diamond Universal Input 100V-277VAC

FEATURES

- OVC III up to 5000m and LPS
- Meets EN55032 “B” floating or earth coupled load
- Full load power: -40 to +60°C
- Reduced load rating to 90°C
- Industry standard pinning [P12]
- Medical; household & industrial standards
- PCB-mount; chassis and DIN-rail mount options
- 3 year warranty

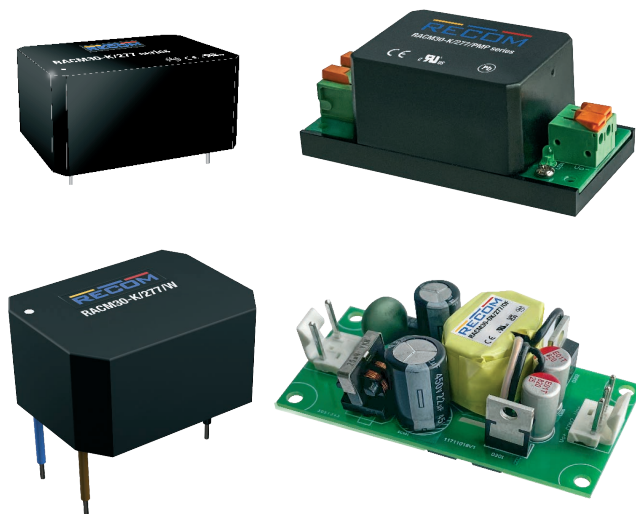

APPLICATIONS

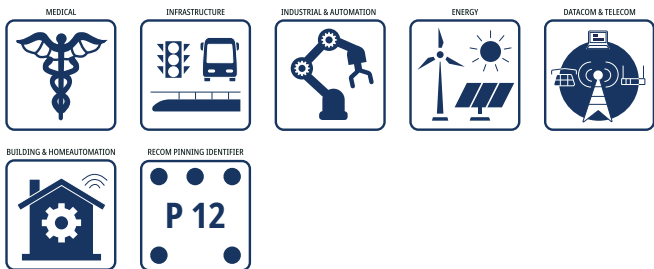

SAFETY & EMC



DESCRIPTION

RACM30-K/277 AC/DC modules provide a leading thermally effective Power yield of 9.2 Watts per inch³ at 60°C still air for continuous loads of 30 Watts plus additional peak capability. These Modules operate in a temperature range of -40° to 90°C in compliance with safety standards of medical MOPP, household-, industrial, and measurement markets. Safety reports rate the series as LPS limited power source and OVCIII for an operating altitude of up to 5000m. Output voltages of 5V up to 54V can supply controller boards, sensors, actuators up to PoE+ power injectors per IEEE 802.3at. A comfortable margin to EMI Class B limits, even with outputs connected to the ground, ease system implementation for quick time-to-market without additional external circuitry such as fuses or filters. For designers, maximum flexibility for these encapsulated, “THT”-through hole technology solder-mountable modules is pin-to-pin compatible with the well-established series RAC20-K. Further mechanical derivatives are potted modules with wires or a panel mount option with spring-clamp connectors which is convertible to DIN-Rail mounting via available RECOM Clip accessory.

SELECTION GUIDE

Part Number	Input Voltage	Output Voltage	Output Current	Efficiency	Max. Capacitive Load
	Range [VAC]	nom. [VDC]	max. [mA]	typ. ⁽¹⁾ [%]	Load ⁽²⁾ [μF]
RACM30-05SK/277	85-305	5	6000	86	10000
RACM30-12SK/277	85-305	12	2500	90	10000
RACM30-15SK/277	85-305	15	2000	90	10000
RACM30-24SK/277	85-305	24	1250	89	8000
RACM30-12DK/277	85-305	±12	±1250	86	±8000
RACM30-15DK/277	85-305	±15	±1000	86	±8000
RACM30-36SK/277	85-305	36	833	88	3000
RACM30-48SK/277	85-305	48	625	88	2000
RACM30-54SK/277	85-305	54	556	88	2000

Note1: Efficiency is tested at nominal input (230VAC) and full load at +25°C ambient

Note2: Measured @ T_{AMB}= 25°C, nom. V_{IN}, full load and after warm-up unless otherwise stated

RACM30-K/277 Series \diamond AC/DC Power Supply

30W \diamond Universal Input 100V-277VAC

MODEL NUMBERING



Note3: without suffix = THT-solder mount, encapsulated
 add suffix "/PMP" = panel mount version with push-in terminals
 add suffix "/PMA" = panel mount version with 45° angled push-in terminal
 add suffix "/W" for wired version (single output only), encapsulated, potted
 add suffix "/OF" = standard 38.1mm x 76.2mm (1.5"x3") open frame version with header connectors

Note4: For other case/connection/footprint options, please contact [RECOM Tech-Support](#).

ACCESSIBLE PART

Part Number	Description	Datasheet Link
RAC-ADAPT-ST-1	adapter board with screw terminals for easy connection	RAC-ADAPT-ST-1.pdf
R-DR/Clip	Din Rail mounting clip only for "/PMP" and "/PMA"	R-DR/CLIP.pdf

ORDERING INFORMATION

Model	nom. Output Voltage	Single/Dual	Package Type Suffix				
			THT-solder mount	"/PMP"	"/PMA"	"/W"	"/OF"
RACM30-05SK/277	5VDC	Single	x	x	on request	x	x
RACM30-12SK/277	12VDC	Single	x	x	x	x	x
RACM30-15SK/277	15VDC	Single	x	N/A	x	x	x
RACM30-24SK/277	24VDC	Single	x	x	on request	x	x
RACM30-36SK/277	36VDC	Single	x	N/A	on request	on request	x
RACM30-48SK/277	48VDC	Single	x	N/A	x	on request	x
RACM30-54SK/277	54VDC	Single	x	N/A	x	x	N/A
RACM30-12DK/277	± 12 VDC	Dual	x	on request	N/A	N/A	x
RACM30-15DK/277	± 15 VDC	Dual	x	on request	N/A	N/A	x

x= standard portfolio / on request= MOQ may apply on project base / N/A= not available

BASIC CHARACTERISTICS (measured @ $T_{AMB} = 25^{\circ}\text{C}$, nom. V_{IN} , full load and after warm-up unless otherwise stated)

Parameter	Condition	Min.	Typ.	Max.
Internal Input Filter				Pi Type
Nominal Input Voltage	50/60Hz	100VAC		277VAC
Operating Range ^(5,6)	47-63Hz	85VAC	230VAC	305VAC
	DC	120VDC		430VDC
Input Current	$V_{IN} = 115\text{VAC}$			650mA
	$V_{IN} = 230\text{VAC}$			350mA
	$V_{IN} = 277\text{VAC}$			300mA
Inrush Current	cold start at $+25^{\circ}\text{C}$	$V_{IN} = 115\text{VAC}$		20A
		$V_{IN} = 230\text{VAC}$		30A
		$V_{IN} = 277\text{VAC}$		36A
No Load Power Consumption	at $+25^{\circ}\text{C}$	230VAC		100mW
Ecodesign Standby Mode Use (Available output power for stated input power)	$V_{IN} = 230\text{VAC}$	$P_{IN} = 0.3\text{W}$		0.22W
		$P_{IN} = 0.5\text{W}$		0.39W
		$P_{IN} = 1\text{W}$		0.79W
Input Frequency Range		47Hz		63Hz
Minimum Load		0%		
Power Factor	$V_{IN} = 115\text{VAC}$		0.6	
	$V_{IN} = 230\text{VAC}$		0.5	
	$V_{IN} = 277\text{VAC}$		0.45	

RACM30-K/277 Series \diamond AC/DC Power Supply

30W \diamond Universal Input 100V-277VAC

BASIC CHARACTERISTICS (measured @ $T_{AMB} = 25^{\circ}\text{C}$, nom. V_{IN} , full load and after warm-up unless otherwise stated)

Parameter	Condition	Min.	Typ.	Max.
Start-up time	$V_{IN} = 230\text{VAC}$			150ms
Rise time	$V_{IN} = 230\text{VAC}$			30ms
Hold-up time	$V_{IN} = 230\text{VAC}$	50ms		
Internal Operating Frequency	100% load at nominal V_{IN}			100kHz
Output Ripple and Noise ⁽⁷⁾	20MHz BW, +25°C	others		100mVp-p
		54VDC		200mVp-p

Note5: The products were submitted for safety files at AC-Input operation, and to IEC/EN61010-1 for DC-operation.

Note6: The selection of a system-adapted DC fuse in the input circuit is recommended

Note7: Measurements are made with a 0.1 μF MLCC & 10 μF E-cap in parallel across output. (low ESR)

RACM30-05SK/277; RACM30-24SK/277

Efficiency vs. Load

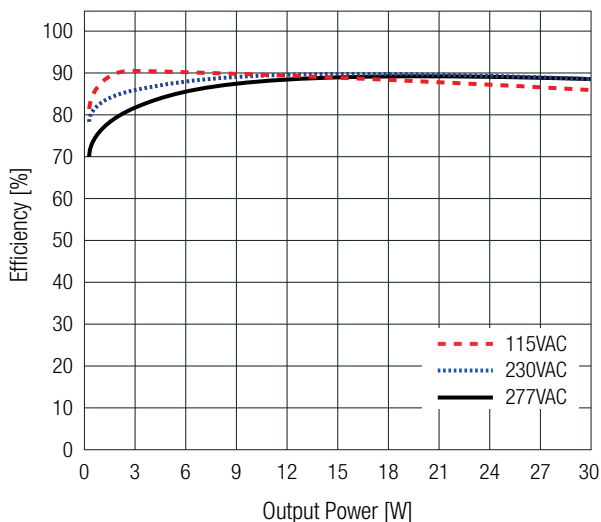

Power Dissipation vs. Load

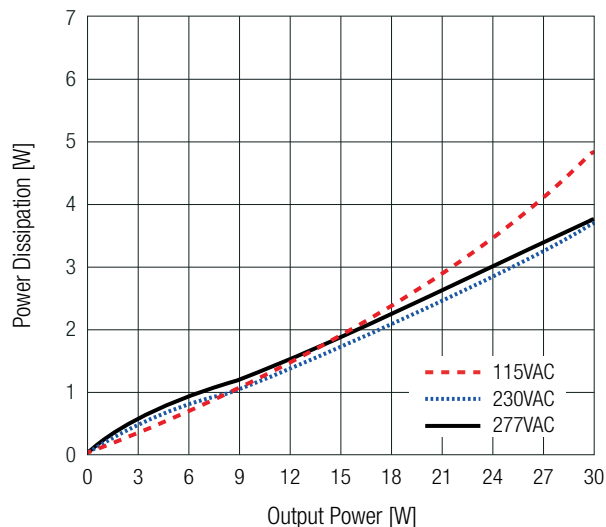

RACM30-12SK/277; RACM30-15SK/277

Efficiency vs. Load

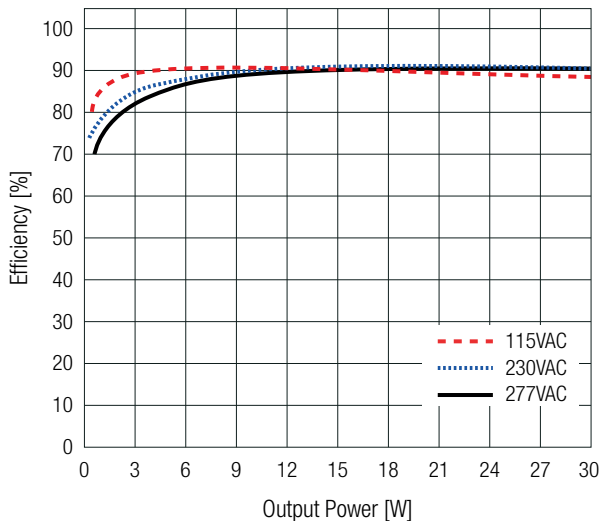

Power Dissipation vs. Load

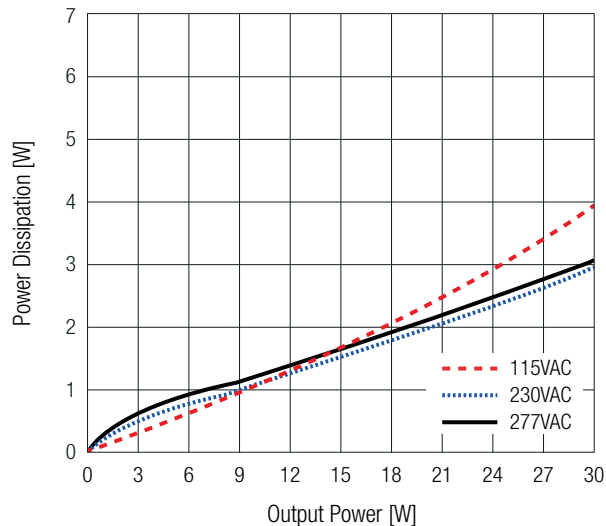

BASIC CHARACTERISTICS (measured @ $T_{AMB} = 25^{\circ}\text{C}$, nom. V_{IN} , full load and after warm-up unless otherwise stated)

RACM30-12DK/277; RACM30-15DK/277

Efficiency vs. Load

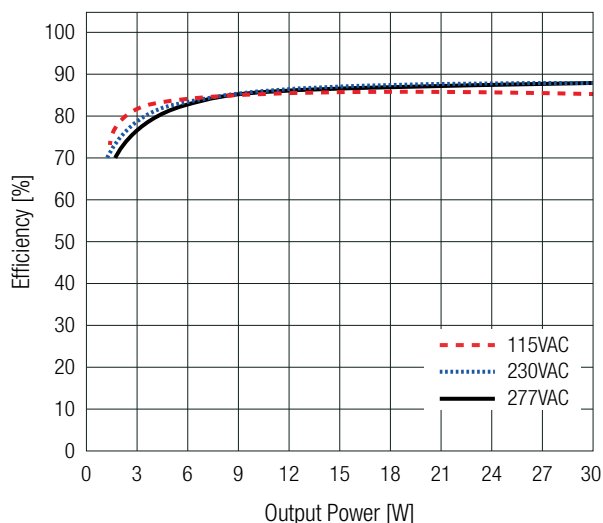

Power Dissipation vs. Load

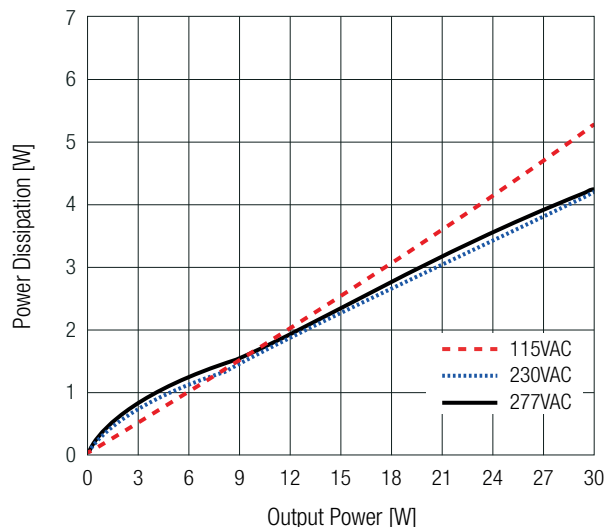

RACM30-36SK/277; RACM30-48SK/277; RACM30-54SK/277

Efficiency vs. Load

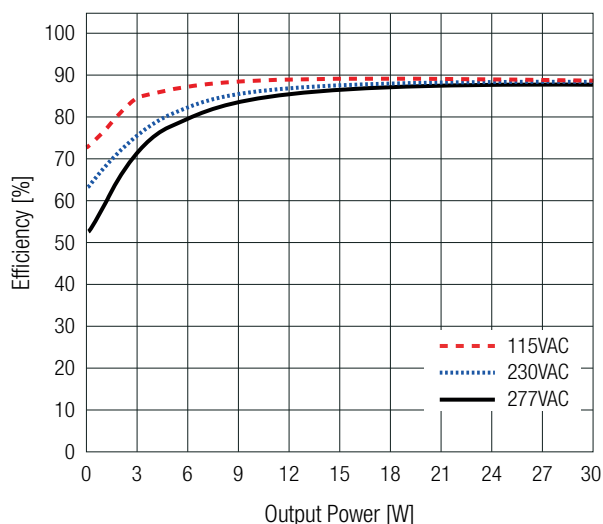

Power Dissipation vs. Load

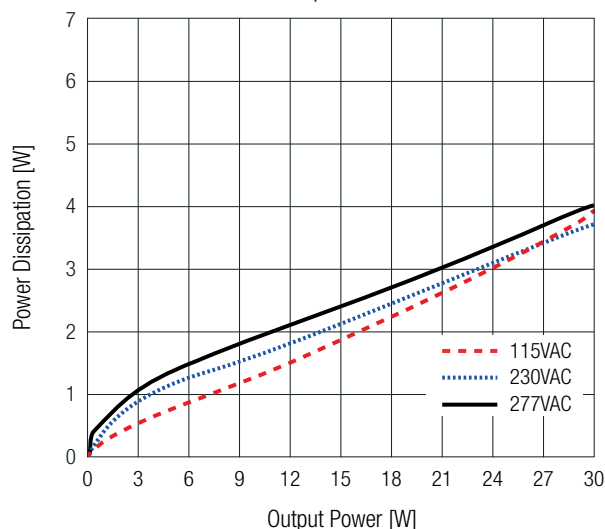

REGULATIONS (measured @ $T_{AMB} = 25^{\circ}\text{C}$, nom. V_{IN} , full load and after warm-up unless otherwise stated)

Parameter	Condition		Value
Output Accuracy	single output		$\pm 2.0\%$ typ.
	dual output		$\pm 3.0\%$ typ.
Line Regulation	low line to high line	5VDC	$\pm 1.0\%$ typ.
		others	$\pm 0.5\%$ typ.
		48, 54VDC	$\pm 1.5\%$ typ.
Load Regulation ⁽⁸⁾	10% to 100% load	5VDC	3.0% typ.
		others	1.0% typ.
		54VDC	$\pm 1.5\%$ typ.
Cross Regulation	dual output only		$\pm 10.0\%$ typ.
Transient Response	25% load step change		4.0% max.
	recovery time		500 μs typ.

Note8: Operation below 10% load will not harm the converter, but specifications may not be met

RACM30-K/277 Series \diamond AC/DC Power Supply

30W \diamond Universal Input 100V-277VAC

PROTECTIONS (measured @ $T_{AMB}= 25^{\circ}\text{C}$, nom. V_{IN} , full load and after warm-up unless otherwise stated)

Parameter	Type		Value
Internal Input Fuse ⁽⁹⁾			T3.15A, slow blow type
Short Circuit Protection (SCP)			hiccup, auto recovery
Over Voltage Protection (OVP)	others		150% - 195%, hiccup mode
	36, 48, 54VDC		120% - 195%, hiccup mode
Over Current Protection (OCP)	others		<180%, hiccup mode
	36, 48, 54VDC		<200%, hiccup mode
Over Voltage Category (OVC II, OVC III, OVC IV @ 100-150VAC Input)	THT-solder mount; "/W"; "/PMP"; "/PMA"		OVC III (5000m)
	"/OF"		OVC III (3000m) / OVC II (5000m)
DC ON LED	only for "/PMP" and "/PMA"		green
Class of Equipment			Class II
Isolation Voltage ⁽¹⁰⁾	I/P to O/P, I/P to case, O/P to case	1 minute	4kVAC
Isolation Resistance	$V_{ISO}= 500\text{VDC}$		1G Ω min.
Isolation Capacitance	I/P to O/P, 100kHz/0.1V		100pF max.
Insulation Grade	I/P to O/P		reinforced
Means of Protection	I/P to O/P		2MOPP
Medical Device Classification	built-in power supply		designed to support type BF applications
Touch Current	264VAC/63Hz	normal condition	<100 μA
		single fault	<500 μA

Note9: For system integration with DC operation, consider a suitable DC fuse in front of the input

Note10: For repeat Hi-Pot testing, reduce the time and/or the test voltage

ENVIRONMENTAL (measured @ $T_{AMB}= 25^{\circ}\text{C}$, nom. V_{IN} , full load and after warm-up unless otherwise stated)

Parameter	Condition		Value		
Operating Ambient Temperature Range	@ natural convection (0.1m/s)	refer to „Derating Graph“	-40°C to +90°C		
Maximum Case Temperature			+110°C		
Temperature Coefficient			0.02%/K		
Operating Altitude ⁽¹¹⁾	according to 62368-1, 60601-1, 61558		5000m		
Operating Humidity	non-condensing		90% RH max.		
Pollution Degree	THT-solder mount; "/W"; "/PMP"; "/PMA"		PD3		
	"/OF"		PD2		
Vibration	according to MIL-STD-202G		10-500Hz, 2G 10min./1cycle, period 60min. each along x,y,z axes		
	THT-solder mount models only	according to IEC 60068-2-27	3 axis, 40 g half sine, 11 ms shock		
		according to IEC 60068-2-65	5-500Hz, 20m/s ² , 1 Oct/min, 15min		
		according to IEC 60068-2-64	10-500Hz; RMS 23,4m/s ² ; 15min		
MTBF	according to MIL-HDBK-217, G.B.	THT-solder mount; "/W"; "/PMP"; "/PMA"	$T_{AMB}= +25^{\circ}\text{C}$ >1357 x 10 ³ hours		
			$T_{AMB}= +40^{\circ}\text{C}$ >1096 x 10 ³ hours		
	"/OF"		$T_{AMB}= +25^{\circ}\text{C}$ >1115 x 10 ³ hours		
			$T_{AMB}= +40^{\circ}\text{C}$ >873 x 10 ³ hours		
Design Lifetime	230VAC/50Hz and full load	THT-solder mount; "/W"; "/PMP"; "/PMA"	single output	5VDC	$T_{AMB}= +45^{\circ}\text{C}$ >30 x 10 ³ hours
				others	$T_{AMB}= +50^{\circ}\text{C}$ >30 x 10 ³ hours
		dual outputs		$T_{AMB}= +40^{\circ}\text{C}$ >30 x 10 ³ hours	
				$T_{AMB}= +50^{\circ}\text{C}$ >17 x 10 ³ hours	
		"/OF"	5VDC	$T_{AMB}= +45^{\circ}\text{C}$ >30 x 10 ³ hours	
			others	$T_{AMB}= +50^{\circ}\text{C}$ >30 x 10 ³ hours	

Note11: Recognized by safety agency for safe operation up to 5000m. High altitude operation may impact the performance and lifetime.

ENVIRONMENTAL (measured @ $T_{AMB} = 25^{\circ}\text{C}$, nom. V_{IN} , full load and after warm-up unless otherwise stated)

Derating Graph

(@ Chamber and natural convection 0.1m/s)

RACM30-05SK/277 (W; /PMP; /PMA)

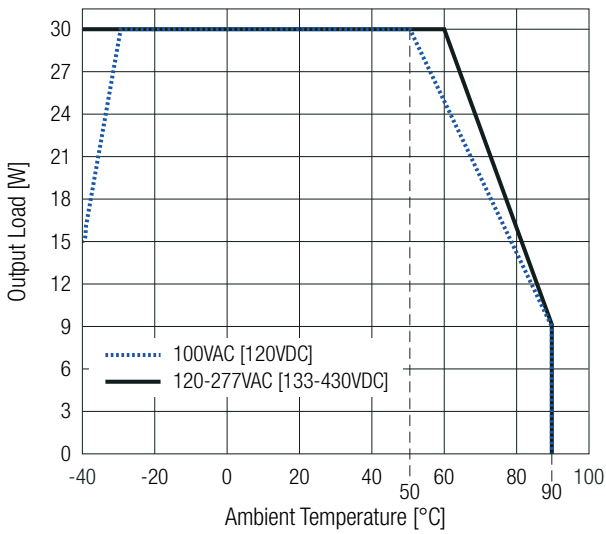

RACM30-xxS(D)K/277 (W; /PMP; /PMA) others

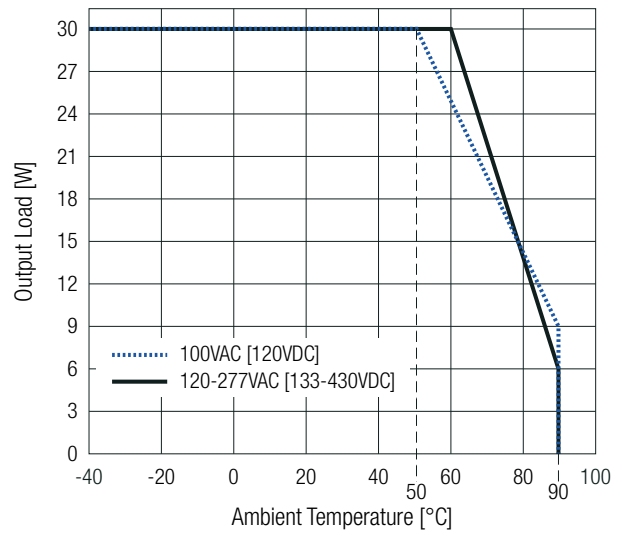

RACM30-05SK/277/OF

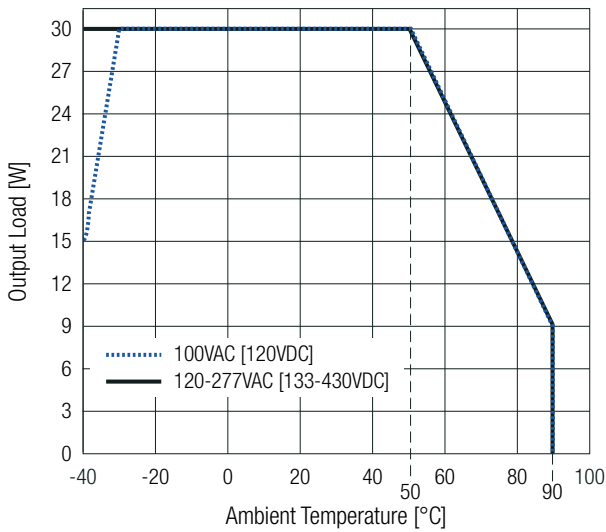

RACM30-xxSK/277/OF others

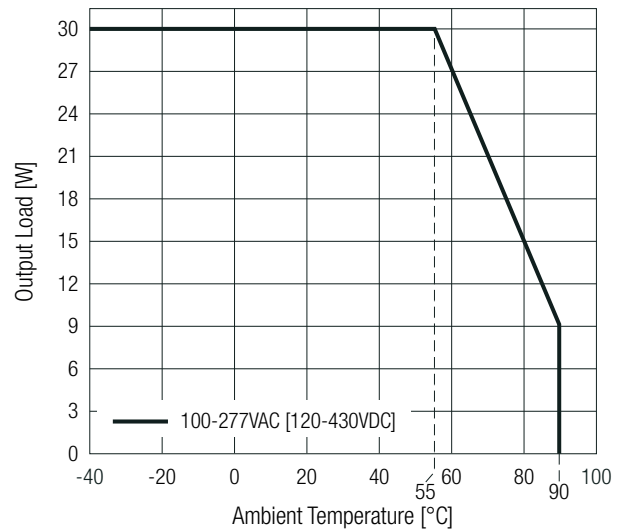

RACM30-xxDK/277/OF

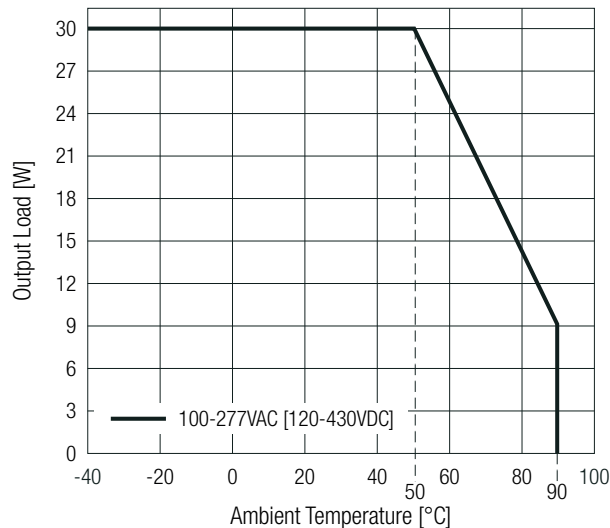

RACM30-K/277 Series \diamond AC/DC Power Supply

30W \diamond Universal Input 100V-277VAC

PEAK LOAD CAPABILITY (SINGLE OUTPUT ONLY)

Calculation:

- P_{nom} = nom. output power (30) [W]
- P_p = peak output power (see table) [W]
- P_r = recovery output power [W]
- t_1 = peak time set (10s max.) [s]
- t_2 = recovery time (min. 5 x t_1) [s]
- k = safety factor 1.1 []

$$P_r = \frac{P_{nom} \times (t_1 + t_2) - (P_p \times t_1)}{t_2 \times k}$$

Maximum Peak Power

nom. V_{OUT} = 5VDC - 12VDC	33W
nom. V_{OUT} = 15VDC - 54VDC	36W

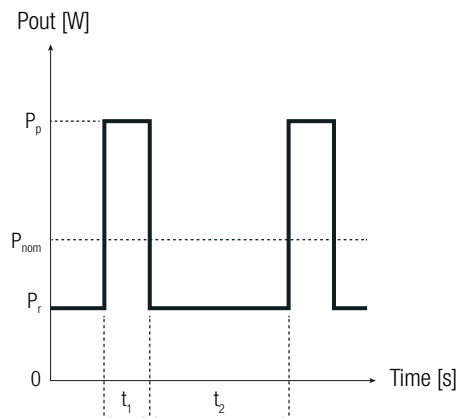

Practical Example (RACM30-24SK/277):

Take the RACM30-24SK/277 at 230VAC input and full load at T_{AMB} = 25°C, with natural convection.

- P_p = 36W
- t_1 = 10s
- t_2 = 50s
- k = 1.1

$$P_r = \frac{30 \times (10 + 50) - (36 \times 10)}{50 \times 1.1} = 26.2W$$

SAFETY & CERTIFICATIONS

Certificate Type (Safety)	Report Number	Standard
Audio/Video, information and communication technology equipment - Part1: Safety requirements (LVD)	64.210.22.02737.02 (except "/>OF" and all 36,48,54VDC)	EN62368-1:2014+A11:2017 (2nd Edition)
Audio/Video, information and communication technology equipment - Safety requirements (CB)	085-220273601-200 (THT-solder mount and "/>OF" only, except all 36,48,54VDC)	IEC62368-1:2018 (3rd Edition)
Audio/Video, information and communication technology equipment - Safety requirements		EN IEC 62368-1:2020+A11:2020 (3rd Edition)
Audio/Video, information and communication technology equipment - Part1: Safety requirements (CB)	241202007	IEC62368-1:2018 (3rd Edition)
Audio/Video, information and communication technology equipment - Part1: Safety requirements	(except "/>PMP; /PMA")	EN IEC 62368-1:2020+A11:2020 (3rd Edition)
Audio/Video, information and communication technology equipment - Part1: Safety requirements	E491408-A6038-UL (except "/>PMP; /PMA")	UL62368-1:2019 (3rd Edition) CAN/CSA-C22.2 No. 62368-1-19 (3rd Edition)
Electrical Equipment For Measurement, Control, and Laboratory Use; Part 1: General Requirements (CB)	085-220277601-000 (except "/>PMA"; "/>OF", and all 36,48,54VDC)	IEC61010-1:2010+A1:2016 3rd Edition with IEC61010-2-201:2017
Electrical Equipment For Measurement, Control, and Laboratory Use; Part 1: General Requirements (LVD)	64.240.22.02776.01 (except "/>PMA"; "/>OF", and all 36,48,54VDC)	EN61010-1:2010+A1:2019 with EN IEC 61010-2-201:2018
Medical electrical equipment Part 1: General requirements for basic safety and essential performance	E511305-D6005-UL	ANSI/AAMI ES60601-1:2005+A1:2012+A2:2021 (Edition 3.2) CAN/CSA-C22.2 No. 60601-1-14+A2:2022 (Edition 3.2)
Medical electrical equipment Part 1: General requirements for basic safety and essential performance (CB)	23SBDS02017-00882	IEC60601-1:2005+C1:2006+C2:2007+AM1:2012 (Edition 3.1)
Medical electrical equipment Part 1: General requirements for basic safety and essential performance	(except all 36,48,54VDC)	EN60601-1:2006+A1:2013+AC:2014
Medical electrical equipment Part 1: General requirements for basic safety and essential performance (CB)	240830022	IEC60601-1:2005+A1:2012+A2:2020 (Edition 3.2)
Medical electrical equipment Part 1: General requirements for basic safety and essential performance		EN60601-1:2006+A1:2013+A12:2014+A2:2021

RACM30-K/277 Series \diamond AC/DC Power Supply

30W \diamond Universal Input 100V-277VAC

SAFETY & CERTIFICATIONS

Certificate Type (Safety)	Report Number	Standard
Household and similar electrical appliances – Safety – Part 1: General requirements (CB)	085-240715301-000	IEC60335-1:2010+A2:2016 5th Edition
Household and similar electrical appliances – Safety – Part 1: General requirements (LVD)		EN60335-1:2012+A11:2014+A13:2017+A1:2019+A14:2019+A2:2019+A15:2021+A16:2023
Measurement methods for electromagnetic fields of household appliances and similar apparatus with regard to human exposure		EN62233:2008
Safety of power transformers, power supplies, reactors and similar products for supply voltages up to 1100 V (CB)		IEC61558-1:2017 (3rd Edition)
Safety of power transformers, power supplies, reactors and similar products for supply voltages up to 1100 V Part 2: Particular requirements (CB)		EN61558-2-16:2009+A1:2013 (1st Edition)
Safety of power transformers, power supplies, reactors and similar products for supply voltages up to 1100 V (CB)	085-220273801-300	IEC61558-1:2017 (3rd Edition)
Safety of power transformers, power supplies, reactors and similar products for supply voltages up to 1100 V Part 2: Particular requirements (CB)		IEC61558-2-16:2009+A1:2013 (1st Edition)
Safety of power transformers, power supplies, reactors and similar products for supply voltages up to 1100 V (LVD)	64.250.22.02738.03	EN IEC 61558-1:2019 (3rd Edition)
Safety of power transformers, power supplies, reactors and similar products for supply voltages up to 1100 V Part 2: Particular requirements (LVD)		EN61558-2-16:2009+A1:2013
RoHS2		RoHS-2011/65/EU + AM-2015/863

EMC Compliance according to EN60601-1-2	Condition	Standard / Criterion
Medical electrical equipment Part 1-2: General requirements for basic safety and essential performance		EN60601-1-2:2015+A1:2021
ESD Electrostatic discharge immunity test	Air +/- 2, 4, 8, 15kV; Contact +/- 8kV	IEC61000-4-2:2008 EN61000-4-2:2009
Radiated, radio-frequency, electromagnetic field immunity test	10 V/m (80-2700MHz), 27V/m (385MHz), 28V/m (450MHz), 9V/m (710, 745, 780MHz), 28V/m (810, 870, 930MHz), 28V/m (1720, 1845, 1970MHz), 28V/m (2450MHz), 9V/m (5240, 5500, 5785MHz)	IEC61000-4-3:2006+A1:2007+A2:2010 EN61000-4-3:2006+A1:2008+A2:2010
Fast Transient and Burst Immunity	AC Power Port L, N, L-N +/-2kV	IEC/EN61000-4-4:2012
Surge Immunity	AC Power Port L-N 0.5, 1, 2kV	IEC/EN61000-4-5:2014+A1:2017
Immunity to conducted disturbances, induced by radio-frequency fields	3, 6Vrms (0.15-80MHz)	IEC61000-4-6:2013 / EN61000-4-6:2014
Voltage Dips	100% (0.5P, 1.0P) 30% (25P,30P)	IEC/EN61000-4-11:2004+A1:2017
Voltage Interruptions	100% (250P/300P)	IEC/EN61000-4-11:2004+A1:2017
Limits of Voltage Fluctuations & Flicker		EN61000-3-3:2013

EMC Compliance according to /EN55032/EN55035	Condition	Standard / Criterion
Electromagnetic compatibility of multimedia equipment – Emission Requirements	O/P: floating or earth coupled (FE; PE or GND)	EN55032:2015+A11:2020, Class B
Electromagnetic compatibility of multimedia equipment – Immunity requirements		EN55035:2017+A11:2020
Radiated, radio-frequency, electromagnetic field immunity test	3V/m (1800MHz, 2600MHz, 3500MHz, 5000MHz)	IEC61000-4-3:2006+A1:2007+A2:2010, Criteria A EN61000-4-3:2006+A1:2008+A2:2010, Criteria A
Fast Transient and Burst Immunity	AC Power Port L, N, L-N 2kV DC Load Line 0.5kV	IEC61000-4-4:2012 / EN61000-4-4:2012, Criteria A

SAFETY & CERTIFICATIONS

EMC Compliance according to EN IEC61204-1	Condition	Standard / Criterion
Low voltage power supplies, d.c. output Part 3: Electromagnetic compatibility (EMC)		EN IEC 61204-3:2018, Class B
ESD Electrostatic discharge immunity test	Air +/-2, 4, 8kV; Contact +/- 4kV / AC and DC input	IEC61000-4-2:2008, Criteria A EN61000-4-2:2009, Criteria A
Radiated, radio-frequency, electromagnetic field immunity test	10V/m (80-1000MHz), 3V/m (1400-2000MHz), 1V/m (2000-2700MHz)	IEC61000-4-3:2006+A1:2007+A2:2010, Criteria A EN61000-4-3:2006+A1:2008+A2:2010, Criteria A
Fast Transient and Burst Immunity	AC Power Port: L, N, L-N \pm 2kV, Criteria B (except 36V, 48V, 54V) AC Power Port: L, N, L-N \pm 2kV, Criteria A (36V and 54V) AC Power Port: L, N, L-N +2kV / Criteria A (48V only) AC Power Port: L, N -2kV / Criteria A (48V only) AC Power Port: L-N -2kV / Criteria B (48V only)	IEC61000-4-4:2012 EN61000-4-4:2012
Surge Immunity	AC Power Port: L-N 0.5, 1, 2kV	IEC/EN61000-4-5:2014+A1:2017, Criteria A
Immunity to conducted disturbances, induced by radio-frequency fields	10Vrms (0.15-80MHz)	IEC61000-4-6:2013, Criteria A EN61000-4-6:2014, Criteria A
Power Magnetic Field Immunity	EN61204-3: 30A/m	IEC61000-4-8:2009, Criteria A EN61000-4-8:2010, Criteria A
Voltage Dips	100% (0.5P, 1.0P) 60% (36V, 48V, 54V) 20% & 30%	IEC/EN61000-4-11:2004+A1:2017, Criteria A
	60% (except 36V, 48V, 54V)	IEC/EN61000-4-11:2004+A1:2017, Criteria B
Voltage Interruptions	100%	IEC/EN61000-4-11:2004+A1:2017, Criteria B
Limits of Harmonic Current Emissions		EN IEC 61000-3-2:2019
Limits of Voltage Fluctuations & Flicker		EN61000-3-3:2013+A1:2019

EMC Compliance according to EN55014-1/EN55014-2	Condition	Standard / Criterion
Electromagnetic compatibility - Requirements for household appliances, electric tools and similar apparatus - Part 1: Emission		EN55014-1:2017
Electromagnetic compatibility - Requirements for household appliances, electric tools and similar apparatus - Part 2: Immunity		EN55014-2:2015
Immunity to conducted disturbances, induced by radio-frequency fields	3Vrms (0.15-230MHz)	IEC61000-4-6:2013, Criteria A EN61000-4-6:2014, Criteria A

DIMENSION & PHYSICAL CHARACTERISTICS

Parameter	Type	Value
Materials	case/baseplate	plastic, (UL94-V0)
	potting	PU, (UL94-V0)
	PCB	FR4, (UL94-V0)
Dimension (LxWxH)	THT-solder mount; "/W"	52.5 x 40.0 x 25.5mm 2.0 x 1.5 x 1.0 inch
	"/PMP"; "/PMA"	84.7 x 40.0 x 33.0mm 3.3 x 1.5 x 1.3 inch
	"/OF"	76.2 x 38.1 x 25.0mm 3.0 x 1.5 x 0.98 inch
Weight	THT-solder mount	93g / 0.21 lbs
	"/PMP"; "/PMA"	122g / 0.27 lbs
	"/W" including wires	98g / 0.22 lbs
	"/OF"	49g / 0.11 lbs

DIMENSION & PHYSICAL CHARACTERISTICS

THT-solder mount version SINGLE and DUAL Output (mm)

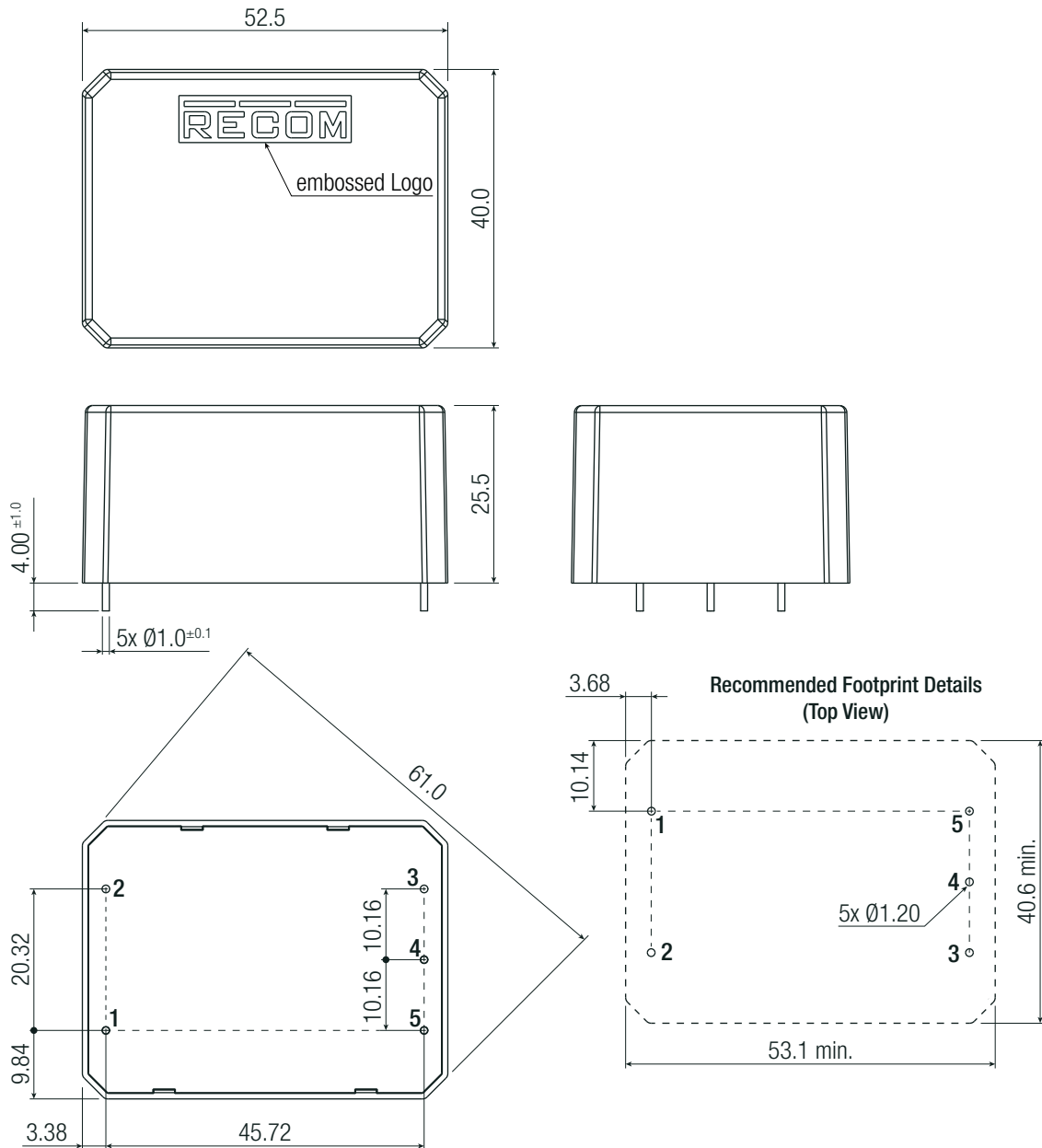
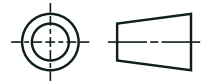

Pinning information [P12]

Pin #	Single	Dual
1	VAC in (N)	VAC in (N)
2	VAC in (L)	VAC in (L)
3	no pin	-Vout
4	-Vout	Com
5	+Vout	+Vout

Tolerance:
 x.x= ±0.5mm
 x.xx= ±0.25mm

DIMENSION & PHYSICAL CHARACTERISTICS

Wired version "/W" SINGLE Output (mm)

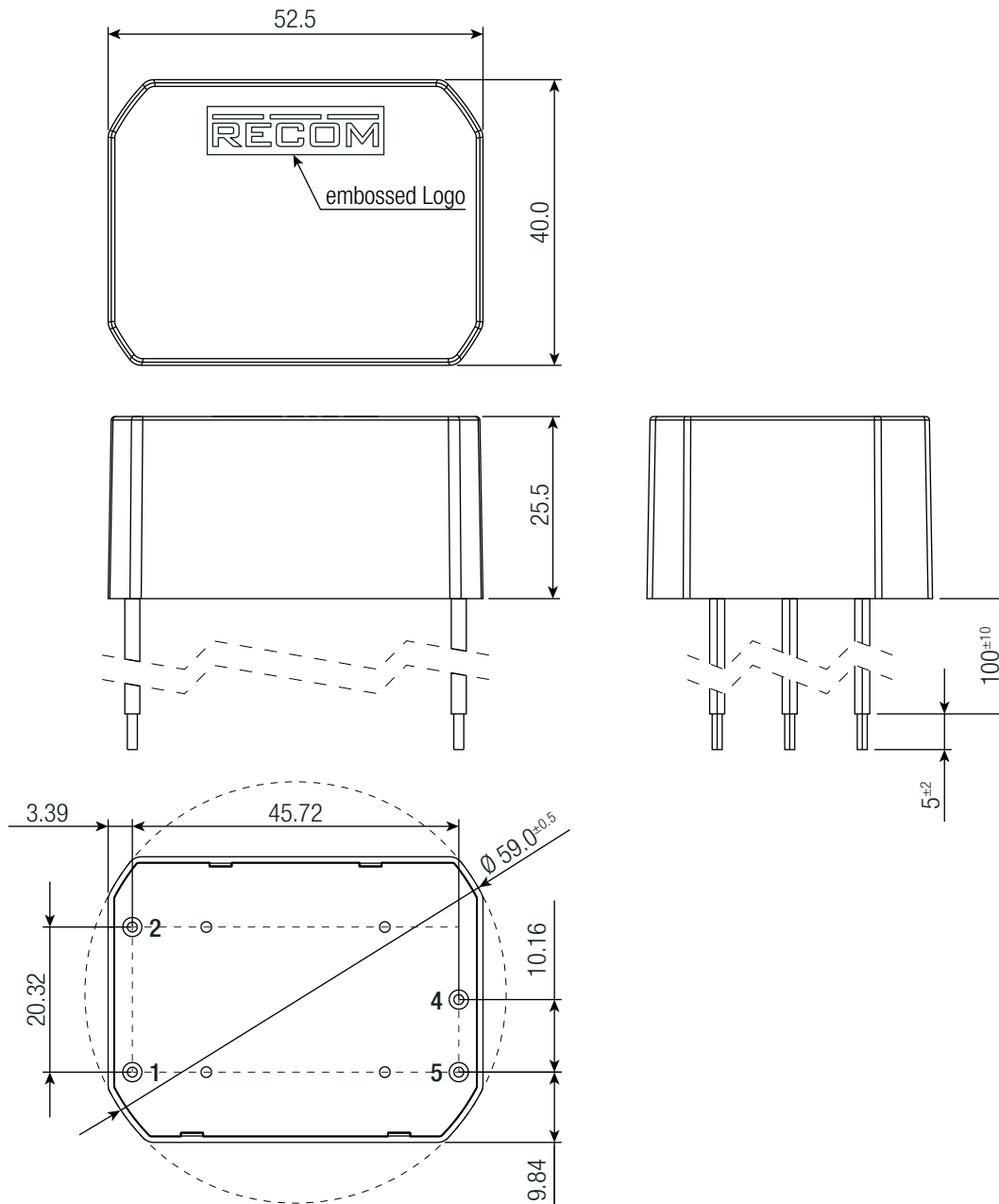
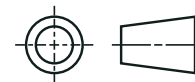

Wire information

#	Function	Wire color	Type	AWG
1	VAC in (N)	blue	UL-1015	18
2	VAC in (L)	brown	UL-1015	18
4	-Vout	black	UL-1015	18
5	+Vout	red	UL-1015	18

Tolerance:
 x.x= ±0.5mm
 x.xx= ±0.25mm

DIMENSION & PHYSICAL CHARACTERISTICS

Open Frame "/OF" SINGLE Output (mm)

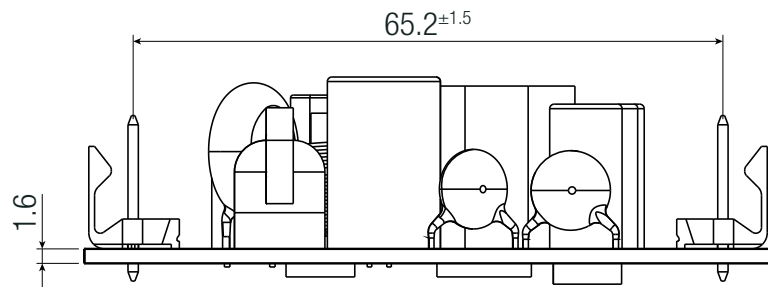
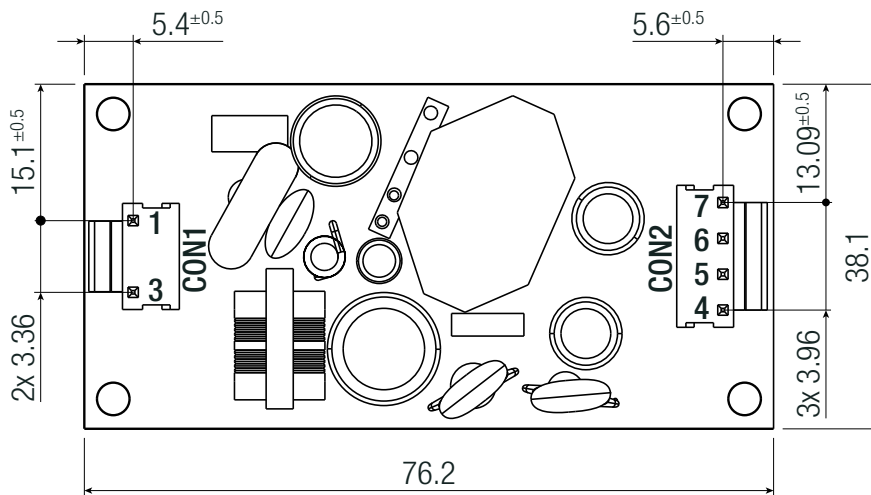

Connector Information - SINGLE

#	Function	Connector
AC Input (CON1)		
1	VAC in (L)	Molex 26-62-4030
3	VAC in (N)	(Pin2 removed)
DC Output Connector (CON2)		
4, 5	+Vout	Molex 26-60-4040
6, 7	-Vout	

FC= fixing centers

Compatible Connector

Housing

Molex 41695 Series or equivalent

Crimp Terminal

Molex 2478 Series or equivalent

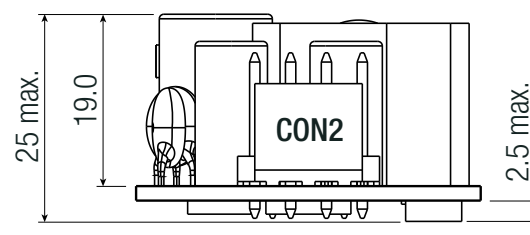
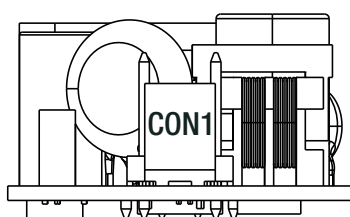
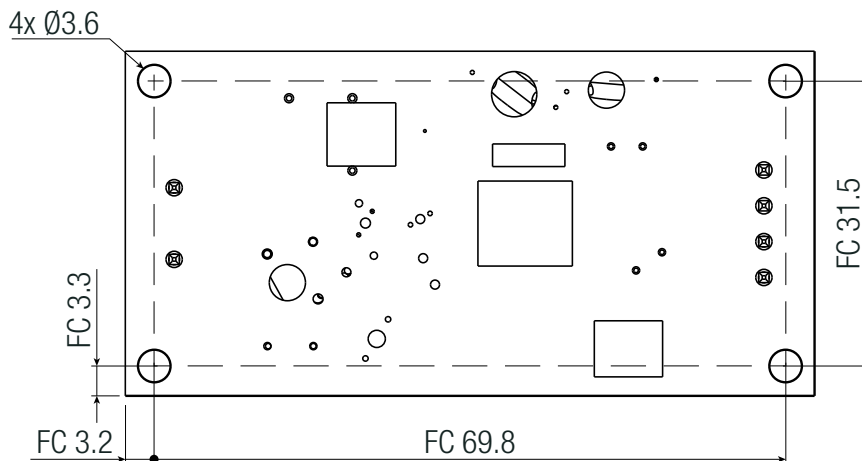

Tolerance:
 x.x= ±0.5mm
 x.xx= ±0.25mm

RACM30-K/277 Series \diamond AC/DC Power Supply

30W \diamond Universal Input 100V-277VAC

DIMENSION & PHYSICAL CHARACTERISTICS

Open Frame "/OF" DUAL Output (mm)

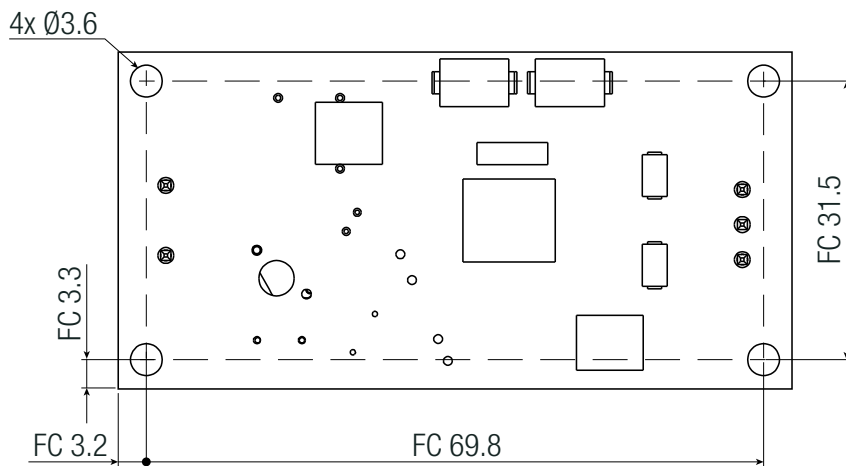
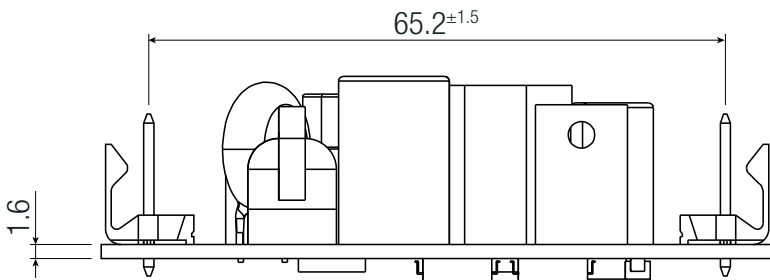
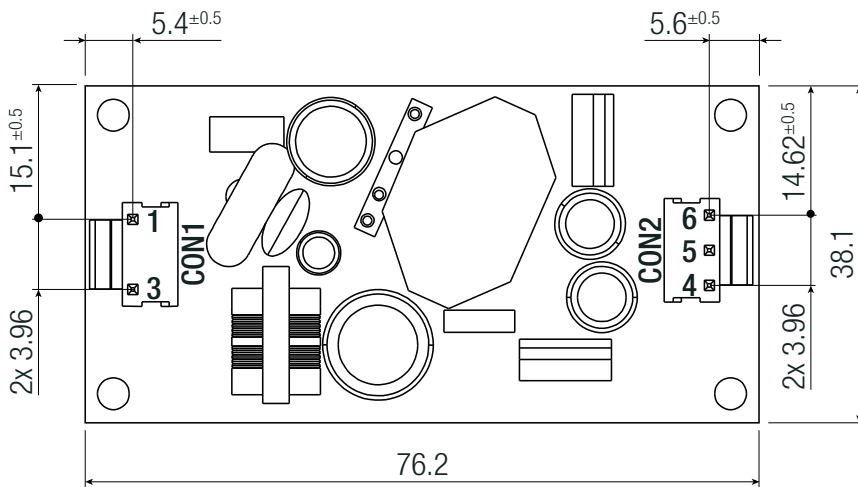

Connector Information - DUAL

#	Function	Connector
AC Input (CON1)		
1	VAC in (L)	Molex 26-62-4030
3	VAC in (N)	(Pin2 removed)
DC Output Connector (CON2)		
4	+Vout	
5	Com	Molex 26-60-4030
6	-Vout	

FC= fixing centers

Compatible Connector

Housing

Molex 41695 Series or equivalent

Crimp Terminal

Molex 2478 Series or equivalent

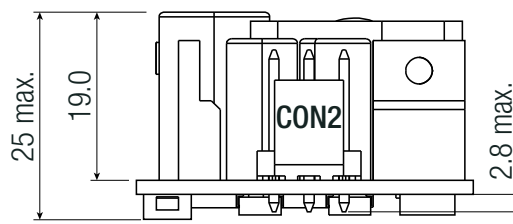
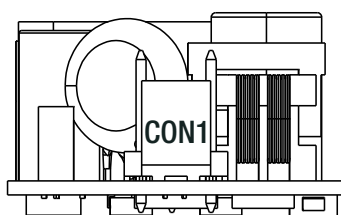

Tolerance:
 x.x= ±0.5mm
 x.xx= ±0.25mm

DIMENSION & PHYSICAL CHARACTERISTICS

Panel Mount "/PMP" SINGLE Output (mm)

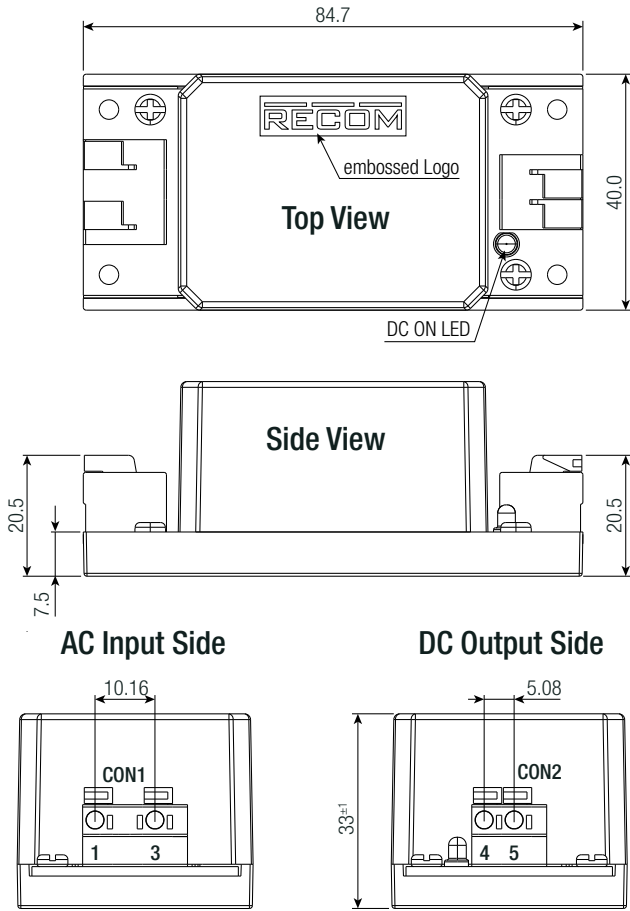

Push-In Spring Terminal

#	Function	Pitch	Terminal Information
AC Input (CON1)			
1	VAC in (N)	10.16mm pitch	Degson
3	VAC in (L)	pin2 removed	(DG142R-5.08-02P-2Y)
DC Output (CON2)			
4	-Vout	2 pins	Degson
5	+Vout	5.08mm pitch	(DG142R-5.08-02P-1Y)

Wire stripping length: 11mm
 Wire cross section: 22-16AWG (0.2-1.5mm²)
 Usable wire cable: Solid and stranded
 FC= fixing centers

Panel Mount "/PMA" SINGLE Output (mm)

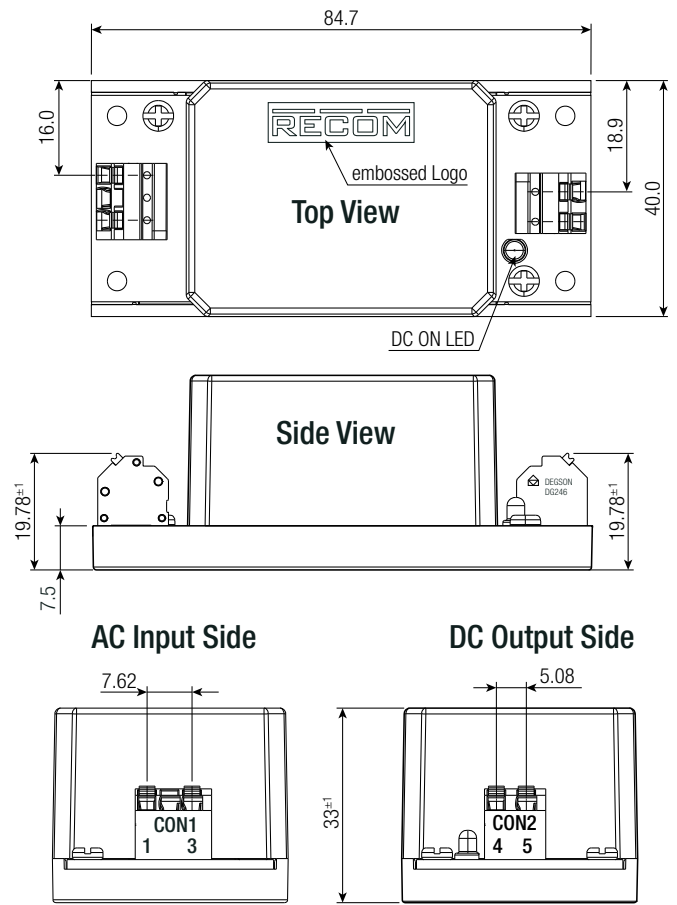

Push-In Spring Terminal

#	Function	Terminal	Terminal Information
AC Input (CON1)			
1	VAC in (N)	7.62mm pitch	Degson
3	VAC in (L)	pin2 removed	(DG246-3.81-02P-24)
DC Output Connector (CON2)			
4	-Vout	2pins	Degson
5	+Vout	5.08mm pitch	(DG246-5.08-02P-14)

Wire stripping length: 10mm
 Wire cross section: 22-16AWG (0.2-1.5mm²)
 Usable wire cable: Solid and stranded
 FC= fixing centers

2x M3x0.5 threads for RECOM accessory [R-DR/CLIP](#) din rail clip
 Recommended countersunk head screw= M3x0.5
 Recommended penetration: 6±0.25mm, Maximum tightening torque: 0.7Nm

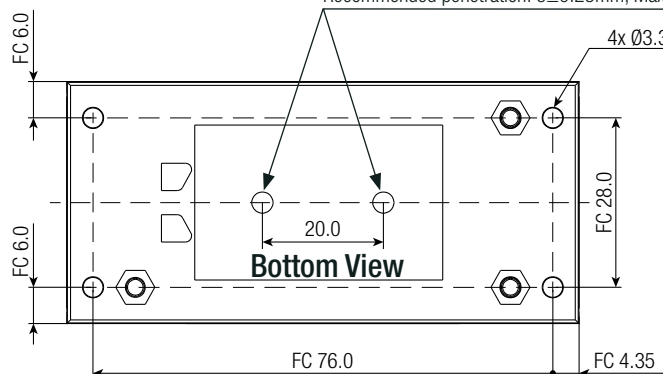

Tolerance:
 x.x= ±0.5mm
 x.xx=0.25mm

INSTALLATION AND APPLICATION

RACM30-K/277/PMP after conversion with the RECOM Din Rail Clip “R-DR/CLIP” accessory part

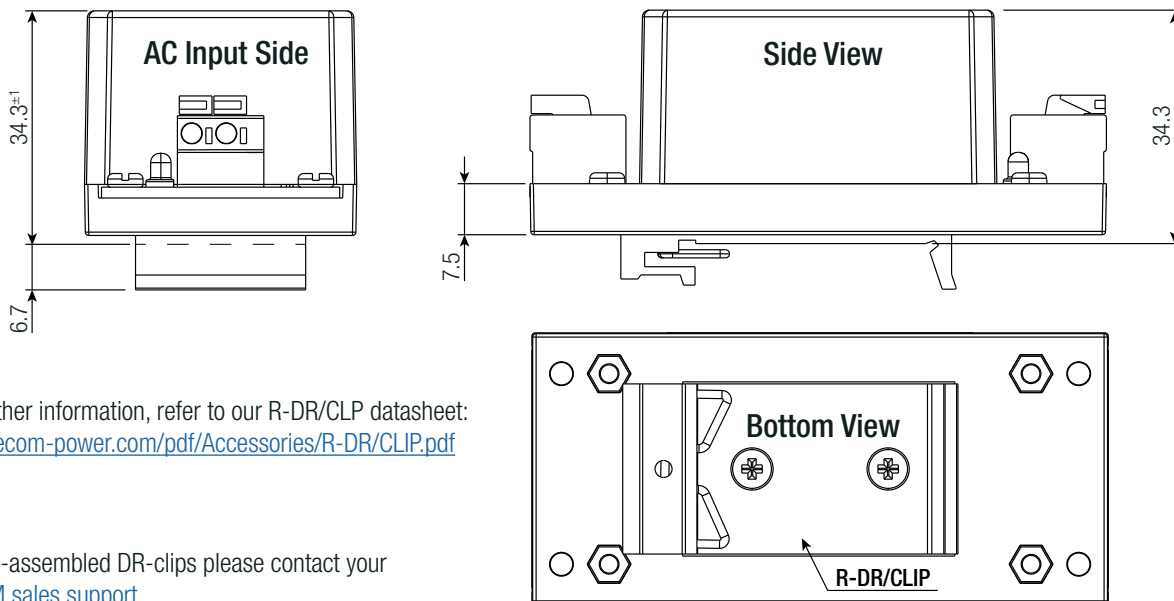

For further information, refer to our R-DR/CLP datasheet: www.recom-power.com/pdf/Accessories/R-DR/CLIP.pdf

For pre-assembled DR-clips please contact your [RECOM sales support](#)

PACKAGING INFORMATION

Parameter	Type		Value
Packaging Dimension (LxWxH)	tube	THT-solder mount	490.0 x 56.0 x 40.0mm
	tray	“/W”; “/PMP”; “/PMA”	405.0 x 360.0 x 55.0mm
		“/OF”	360.0 x 205.0 x 50.0mm
Packaging Quantity	THT-solder mount		11pcs
	“/W”; “/PMP”; “/PMA”		24pcs
	“/OF”		12pcs
Storage Temperature Range			-40°C to +90°C
Storage Humidity	non-condensing		95% RH max.

The product information and specifications may be subject to changes even without prior written notice. The product has been designed for various applications; its suitability lies in the responsibility of each customer. The products are not authorized for use in safety-critical applications without RECOM's explicit written consent. A safety-critical application is an application where a failure may reasonably be expected to endanger or cause loss of life, inflict bodily harm or damage property. The applicant shall indemnify and hold harmless RECOM, its affiliated companies and its representatives against any damage claims in connection with the unauthorized use of RECOM products in such safety-critical applications.

Looking for pricing, stock, or lifecycle information?

Click below to explore more details on WIN SOURCE:

- ⊖ [View RACM30-12SK/277](#) on WIN SOURCE
- ⊖ [Recom Power](#) Information

Optimize Your Supply Chain with WIN SOURCE Solutions

- ✓ Global Sourcing Solution
- ✓ Obsolete Management
- ✓ Cost Control Management
- ✓ Shortage Management
- ✓ Alternative Solution
- ✓ Excess Inventory Management