

Product Overview

Qorvo’s QPM1021 is a packaged, high power amplifier fabricated on Qorvo’s production 0.15 um GaN on SiC process. The QPM1021 operates from 10–12 GHz and provides 100 W (50 dBm) of saturated output power with 20 dB of large signal gain and greater than 32 % power-added efficiency.

The QPM1021 is packaged in a 10-lead 19.05 x 19.05 mm bolt-down package, with a pure copper base for superior thermal management. Both RF ports are internally DC blocked and matched to 50 ohms allowing for simple system integration.

The QPM1021 is ideally suited for both commercial and military radar systems, satellite communications systems, and data links.

RoHS compliant.

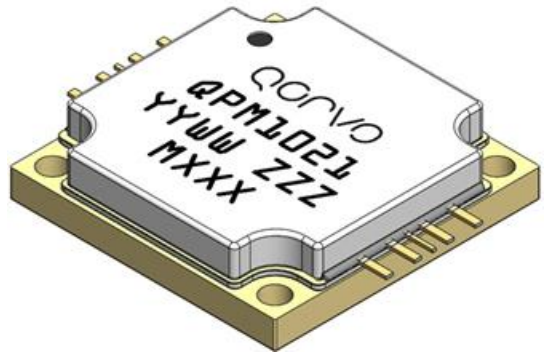

Key Features

- Frequency Range: 10 – 12 GHz
- P_{SAT} : > 50 dBm ($P_{IN} = 28$ dBm)
- PAE: > 32% ($P_{IN} = 28$ dBm)
- Large Signal Gain: > 20 dB ($P_{IN} = 28$ dBm)
- Small Signal Gain: > 26 dB
- Bias: $V_D = 28$ V, $I_{DQ} = 2.0$ A
- Package Dimensions: 19.05 x 19.05 x 4.52 mm
- Performance Under Pulsed Operation

Performance is typical across frequency. Please reference electrical specification table and data plots for more details.

Functional Block Diagram

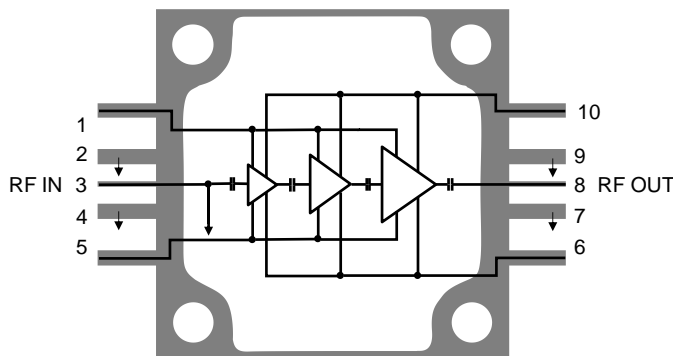

Top View

Applications

- Radar
- Electronic Warfare

Ordering Information

Part No.	Description
QPM1021	10–12 GHz 100 Watt GaN Power Amplifier (20 pcs.)
QPM1021S2	QPM1021 Samples (2 pcs.)
QPM1021EVB	QPM1021 Evaluation Board

Absolute Maximum Ratings

Parameter	Min Values	Max Values	Units
Drain Voltage (V_D)		29.5	V
Gate Voltage Range (V_G)	-5	0	V
Drain Current (I_D)		18.2	A
Gate Current (I_G)	See plot pg. 12		
Power Dissipation (P_{DISS}), 85 °C, Pulsed; PW = 150 us, DC = 20%		435	Watts
Input Power (P_{IN}), 50 Ω , 85 °C, $V_D = 28$ V, Pulsed; PW = 150 us, DC = 20%		32	dBm
Input Power (P_{IN}), 85 °C, VSWR 3:1, $V_D = 28$ V, Pulsed; PW = 150 us, DC = 20%		38	dBm
Mounting Temperature	Refer to Assembly Notes, page 16		
Storage Temperature	-55	150	°C

Exceeding any one or a combination of the Absolute Maximum Rating conditions may cause permanent damage to the device. Extended application of Absolute Maximum Rating conditions to the device may reduce device reliability.

Recommended Operating Conditions

Parameter	Min	Typ	Max	Units
Drain Voltage (V_D)		28		V
Drain Current (I_{DQ})		2.0		A
Operating Temperature Range	-40	25	85	°C

Electrical specifications are measured at specified test conditions. Specifications are not guaranteed over all recommended operating conditions.

Electrical Specifications

Parameter	Conditions ⁽¹⁾	Min	Typ	Max	Units
Frequency Range		10		12	GHz
Output Power	$P_{IN} = 28$ dBm, Pulsed	10.0 GHz	49.5	51.3	dBm
		11.2 GHz	48.0	50.3	
		12.0 GHz	48.0	50.4	
Power Added Efficiency	$P_{IN} = 28$ dBm, Pulsed	10.0 GHz	22.0	32.9	%
		11.2 GHz	20.8	29.4	
		12.0 GHz	19.2	26.2	
P_{OUT} Temperature Coefficient	Temp: 25 °C to 85 °C, $P_{IN} = 28$ dBm)		-0.012		dB/°C
Small Signal Gain		10.0 GHz		26.6	dB
		11.2 GHz		22.8	
		12.0 GHz		20.2	
Input Return Loss			13		dB
Output Return Loss			11		dB
Small Sig. Gain Temp. Coefficient	Temp: -40°C to 85 °C		-0.110		dB/°C
Recommended Operating Voltage		24	28	28	V

Notes:

Test conditions unless otherwise noted: T = 25 °C, $V_D = 28$ V, $I_{DQ} = 2.0$ A, PW = 150 us, Duty Cycle = 20%

Performance Plots – Large Signal

Test conditions unless otherwise noted: $T = 25\text{ }^{\circ}\text{C}$, $V_D = 28\text{ V}$, $I_{DQ} = 2.0\text{ A}$, $P_{IN} = 28\text{ dBm}$, $PW = 150\text{ }\mu\text{s}$, Duty Cycle = 20%

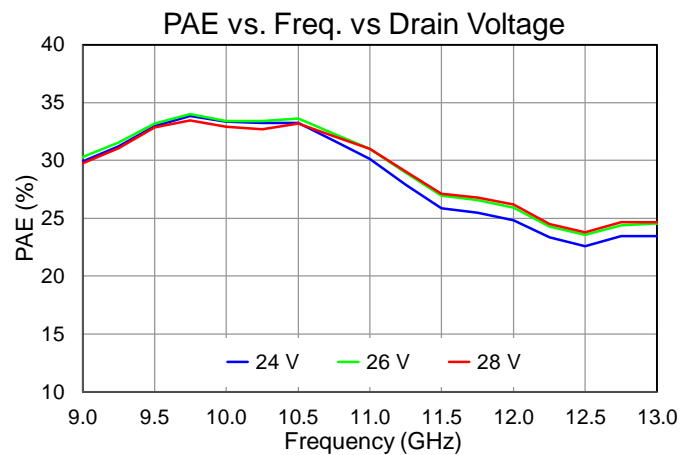
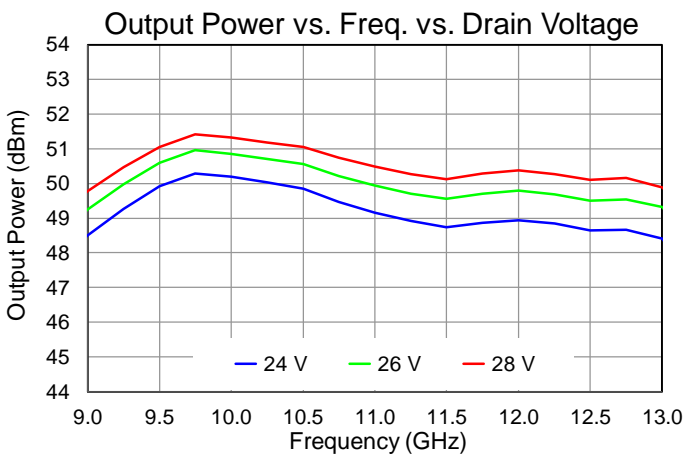
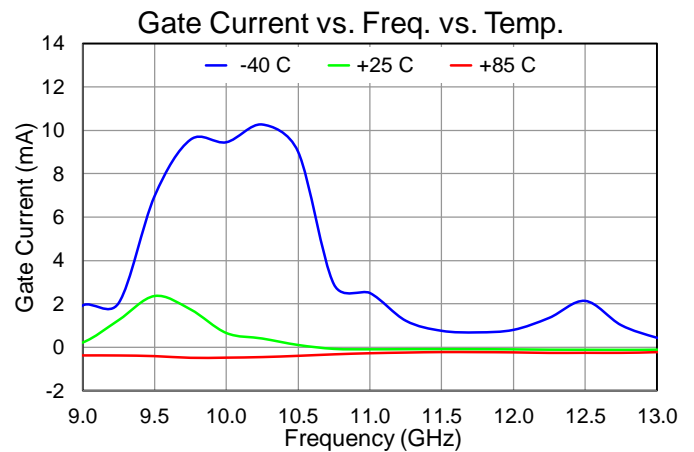
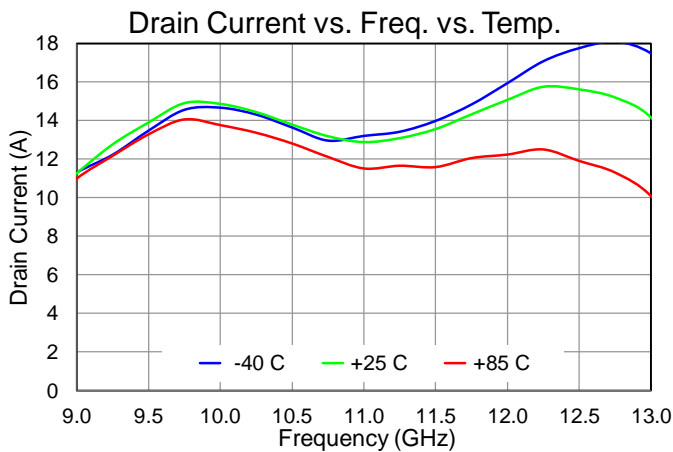
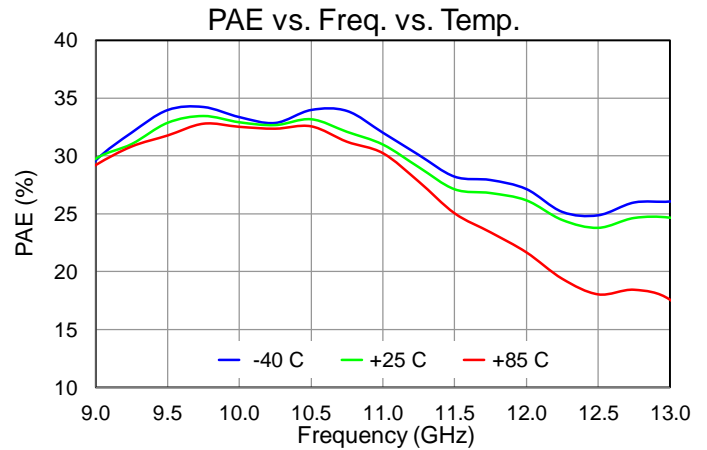
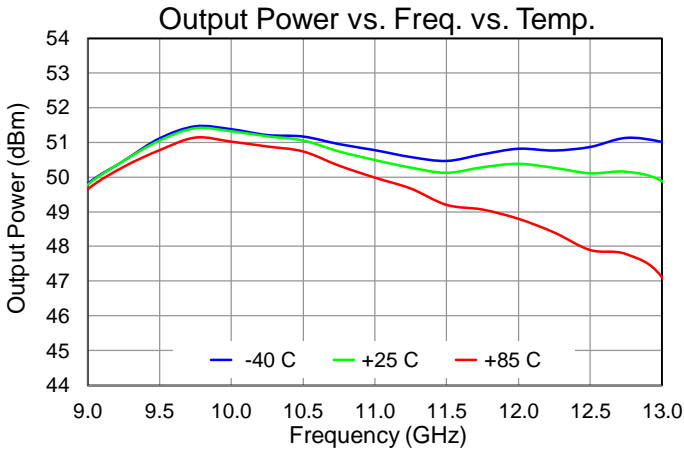

Performance Plots – Large Signal

Test conditions unless otherwise noted: $T = 25\text{ }^{\circ}\text{C}$, $V_D = 28\text{ V}$, $I_{DQ} = 2.0\text{ A}$, $P_{IN} = 28\text{ dBm}$, $PW = 150\text{ }\mu\text{s}$, Duty Cycle = 20%

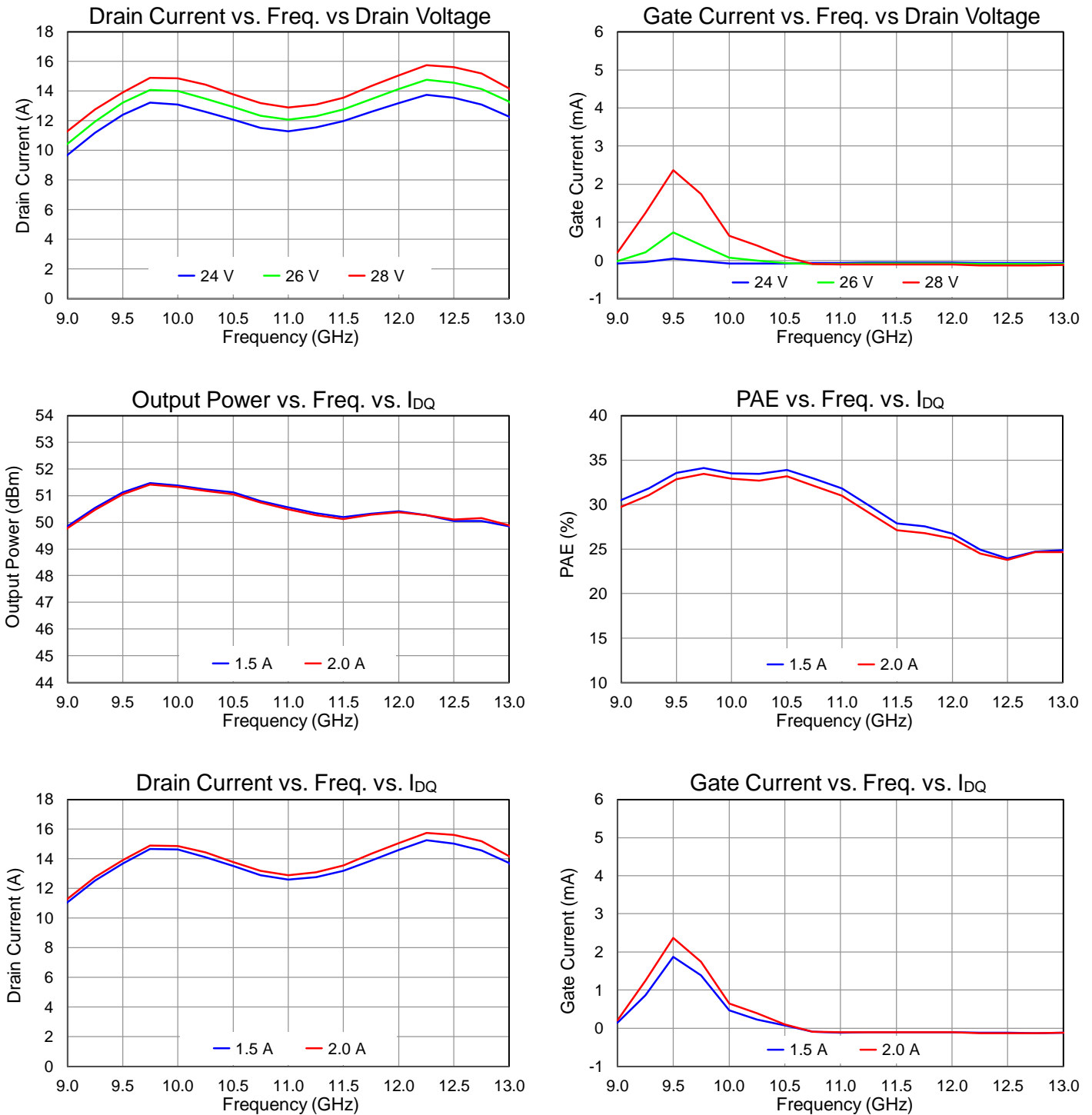

Performance Plots – Large Signal

Test conditions unless otherwise noted: $T = 25\text{ }^{\circ}\text{C}$, $V_D = 28\text{ V}$, $I_{DQ} = 2.0\text{ A}$, $P_{IN} = 28\text{ dBm}$, $PW = 150\text{ }\mu\text{s}$, Duty Cycle = 20%

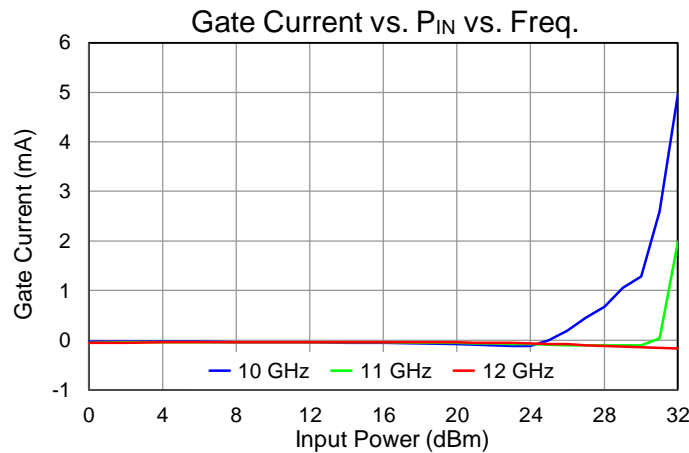
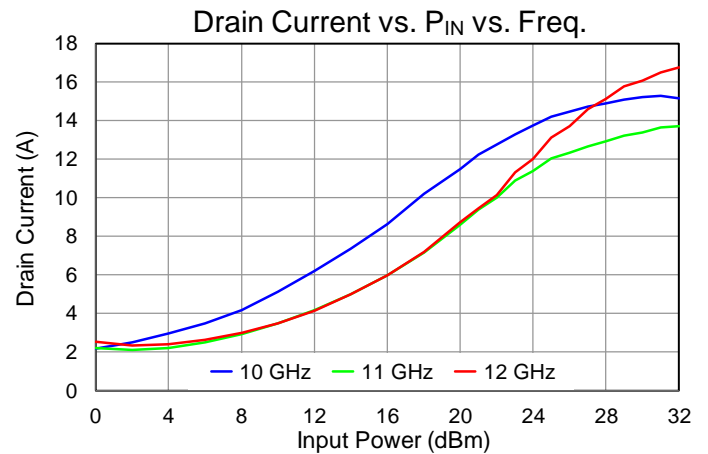
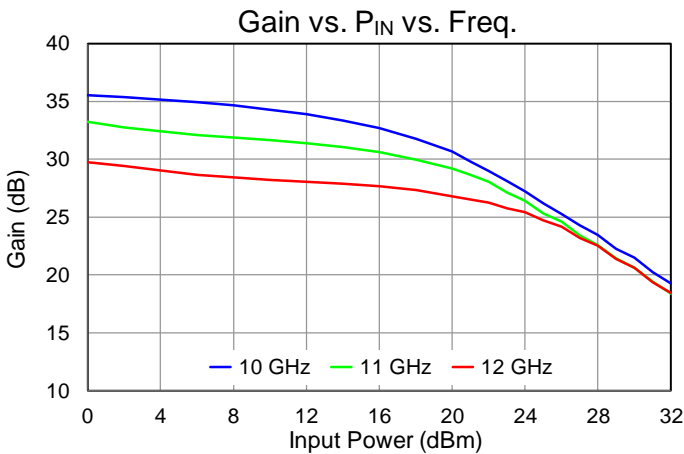
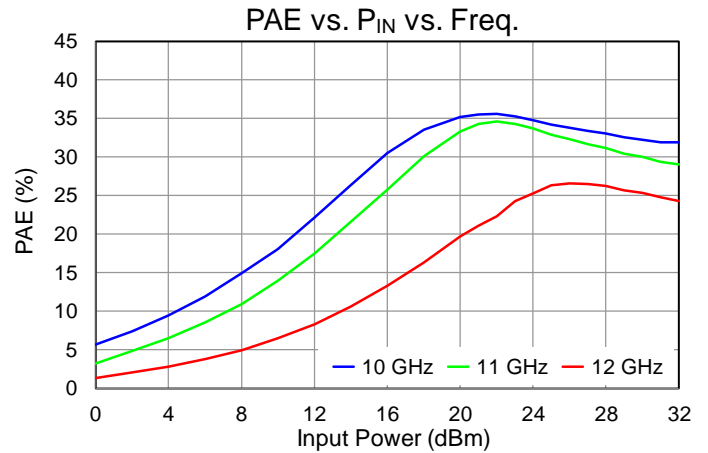
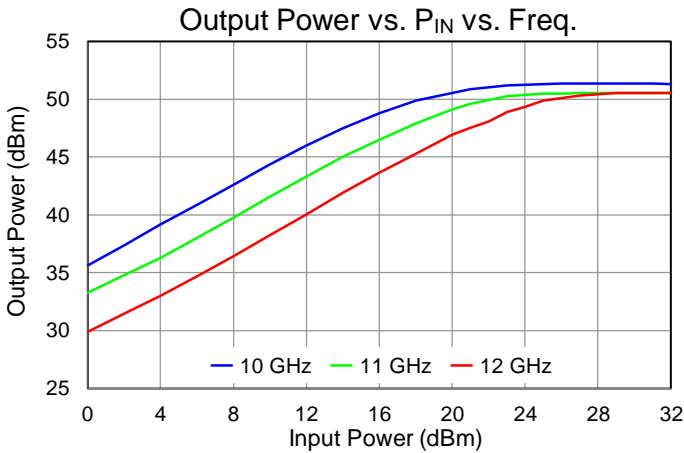

Performance Plots – Large Signal

Test conditions unless otherwise noted: $T = 25\text{ }^{\circ}\text{C}$, $V_D = 28\text{ V}$, $I_{DQ} = 2.0\text{ A}$, $\text{Freq} = 11\text{ GHz}$, $\text{PW} = 150\text{ }\mu\text{s}$, $\text{Duty Cycle} = 20\%$

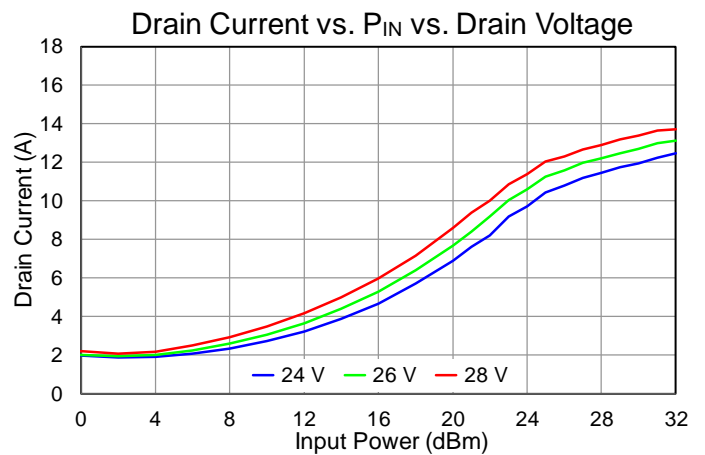
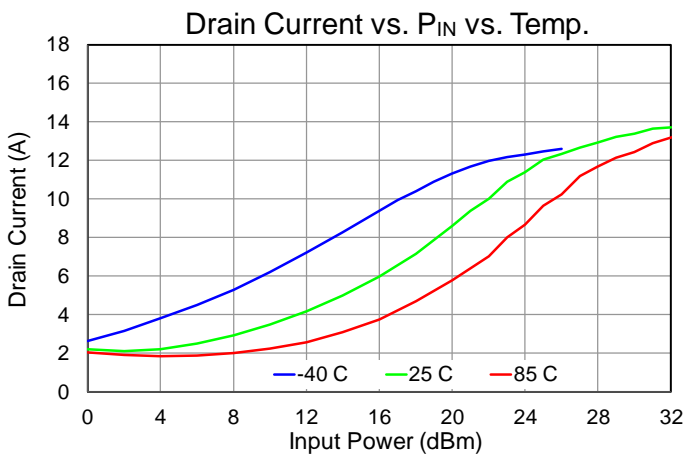
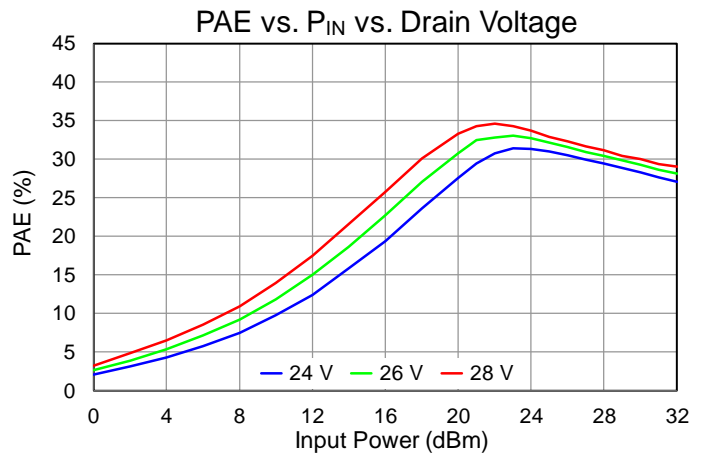
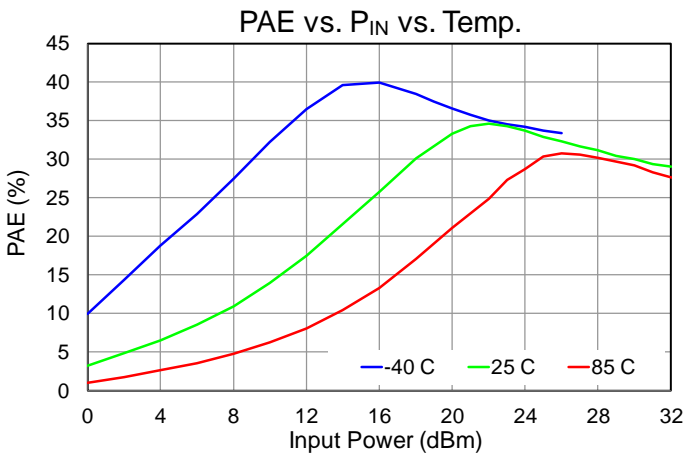
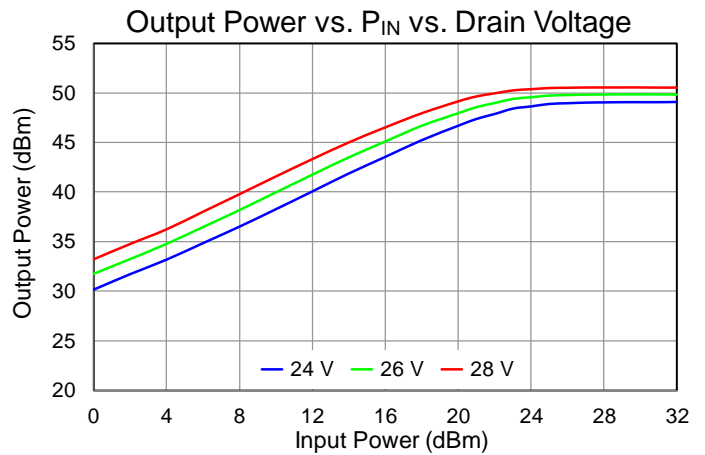
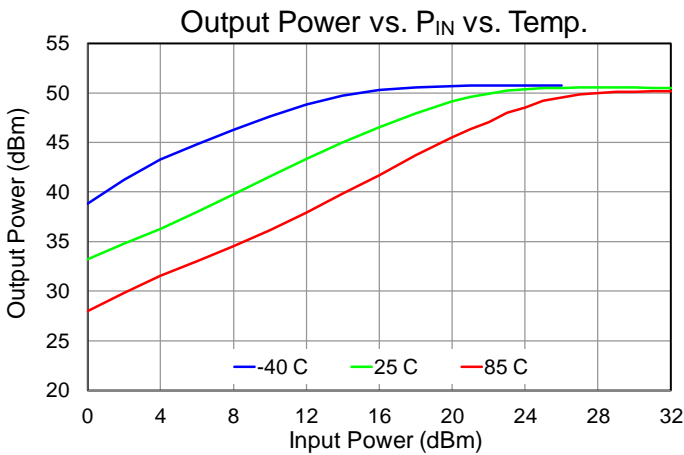

Performance Plots – Large Signal

Test conditions unless otherwise noted: $T = 25\text{ }^{\circ}\text{C}$, $V_D = 28\text{ V}$, $I_{DQ} = 2.0\text{ A}$, $\text{Freq} = 11\text{ GHz}$, $\text{PW} = 150\text{ }\mu\text{s}$, $\text{Duty Cycle} = 20\%$

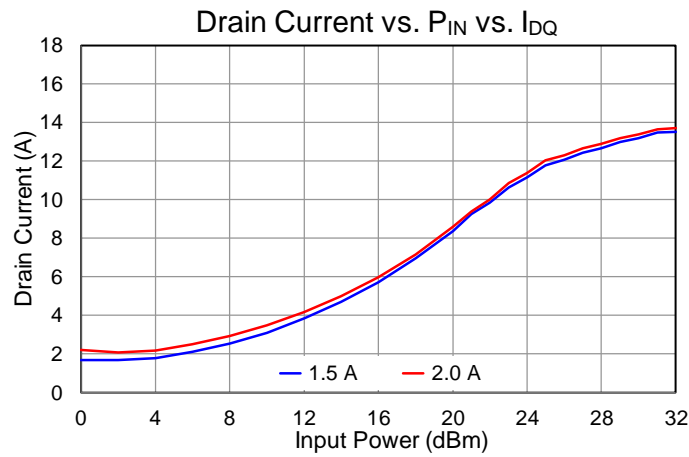
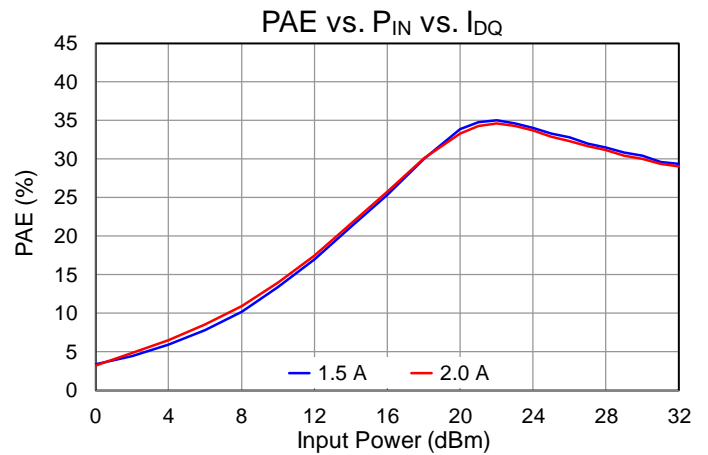
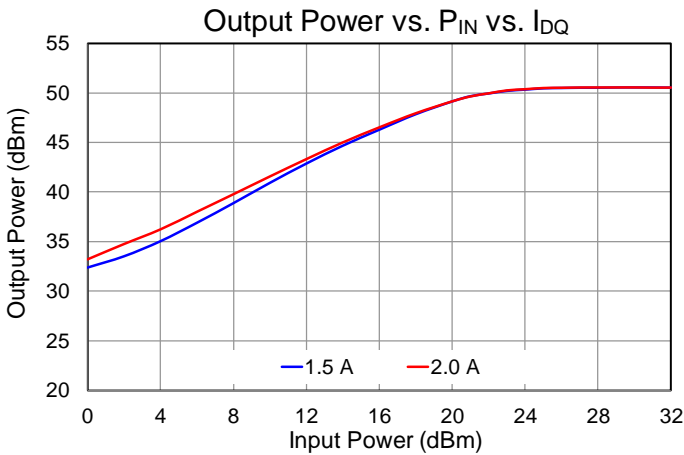

Performance Plots – Harmonics

Test conditions unless otherwise noted: $T = 25\text{ }^{\circ}\text{C}$, $V_D = 28\text{ V}$, $I_{DQ} = 2.0\text{ A}$, $PW = 150\text{ }\mu\text{s}$, Duty Cycle = 20%

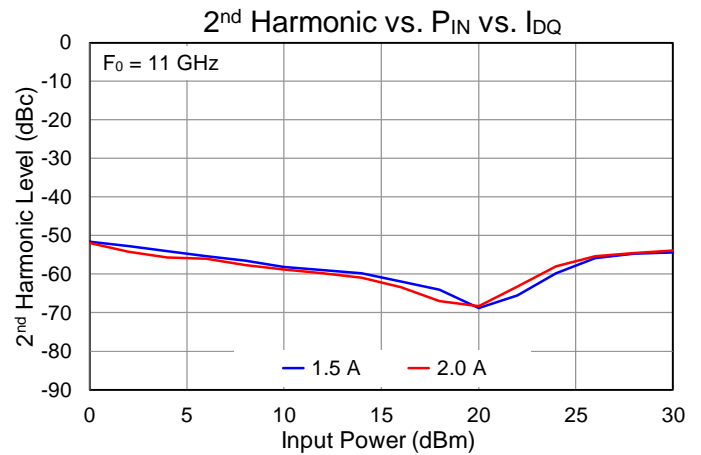
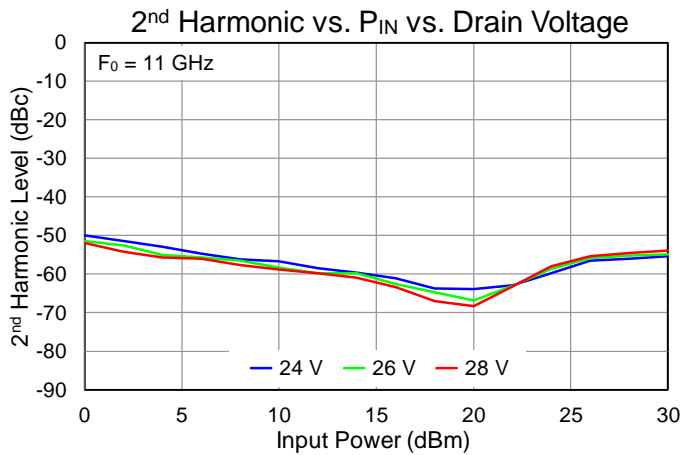
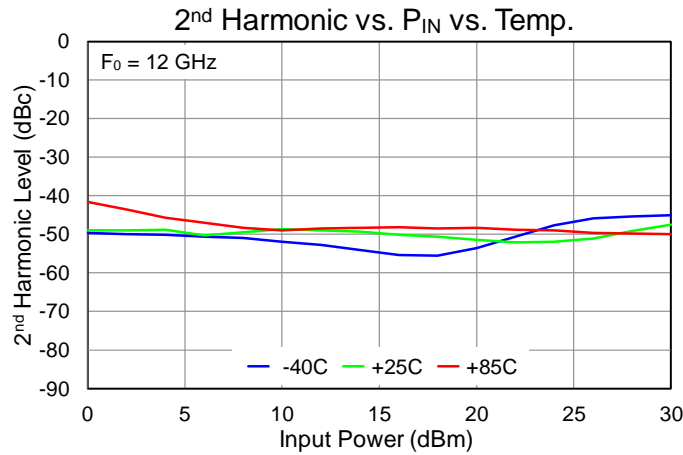
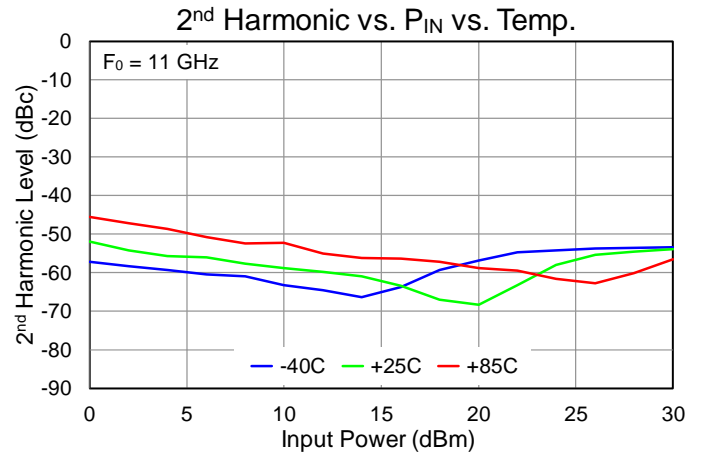
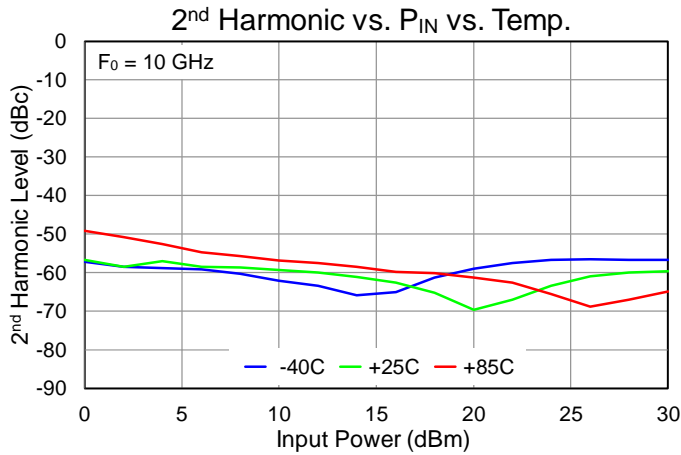

Performance Plots – Linearity

Test conditions unless otherwise noted: $V_D = 28\text{ V}$, $I_{DQ} = 2.0\text{ A}$, $PW = 150\text{ }\mu\text{s}$, Duty Cycle = 20%, Tone Spacing = 100 MHz, 25 °C

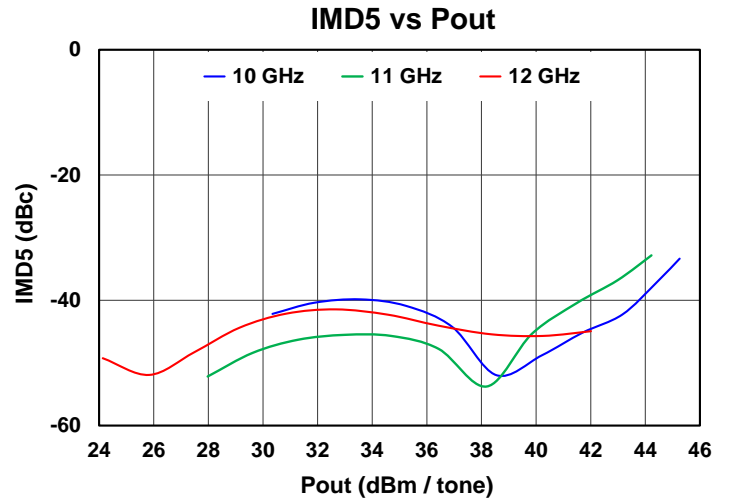
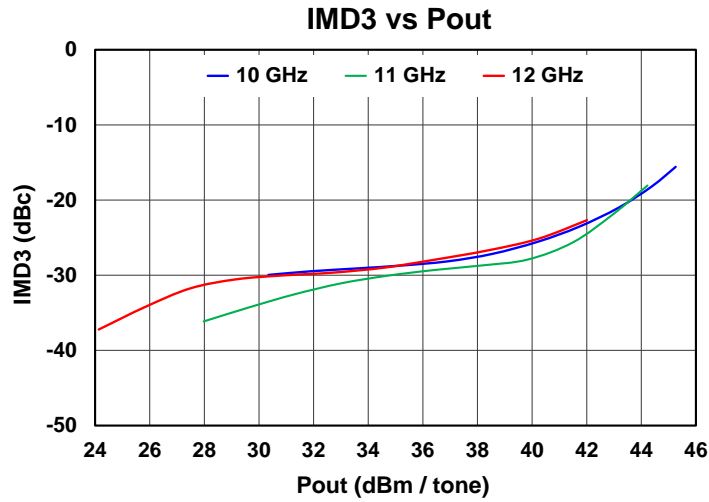

Performance Plots – Small Signal

Test conditions unless otherwise noted: T = 25 °C, V_D = 28 V, I_{bq} = 2.0 A

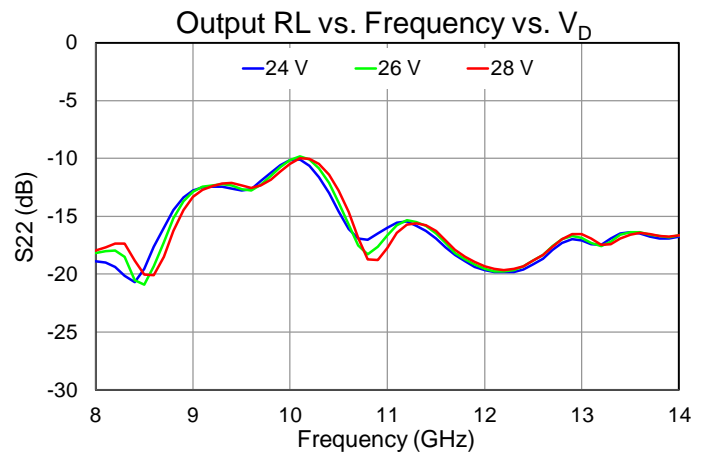
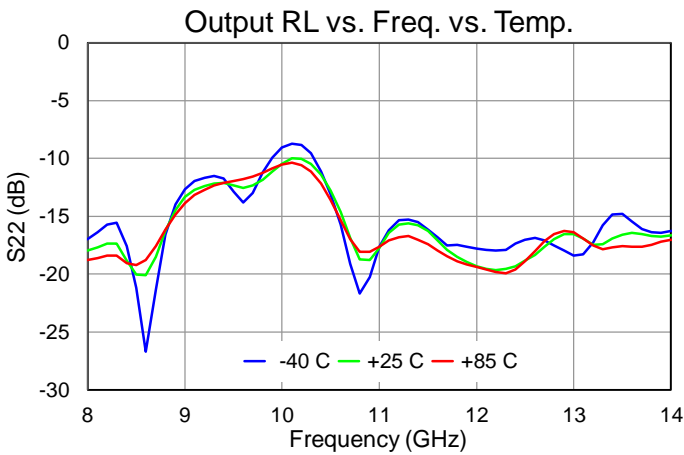
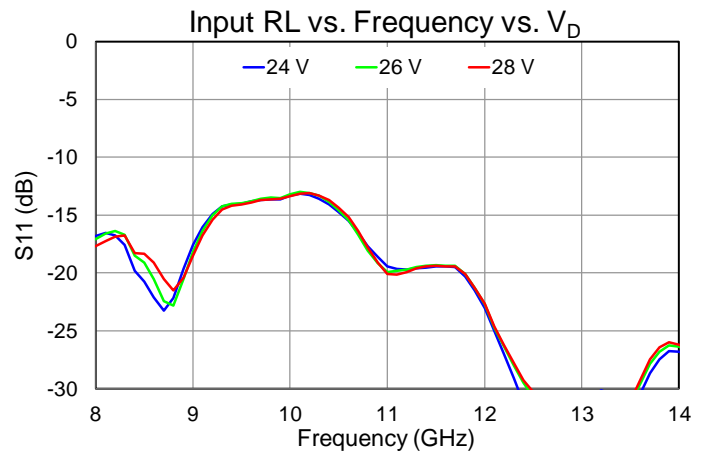
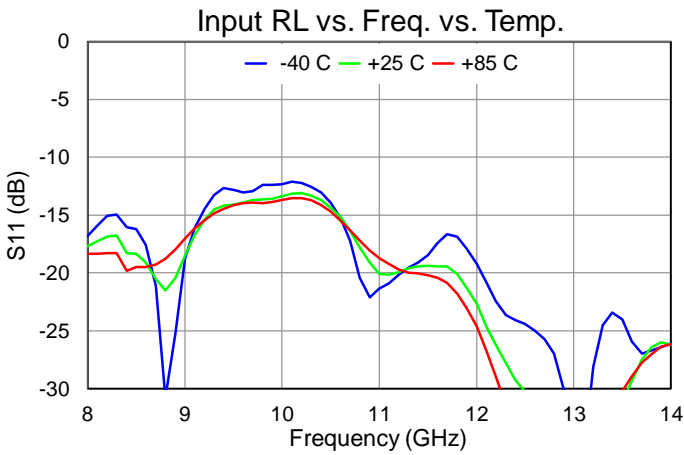
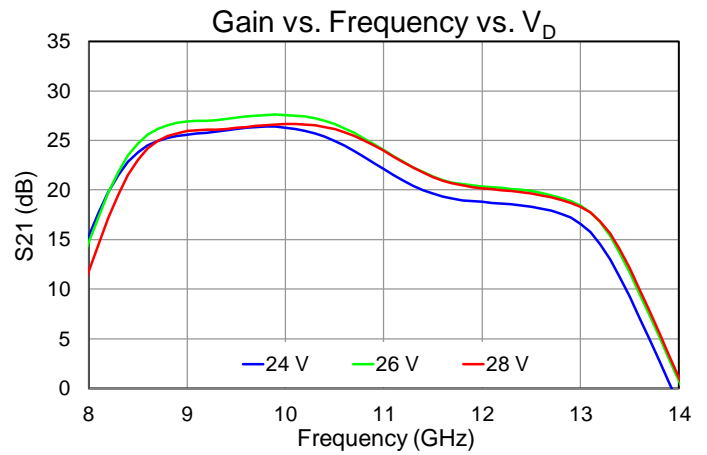
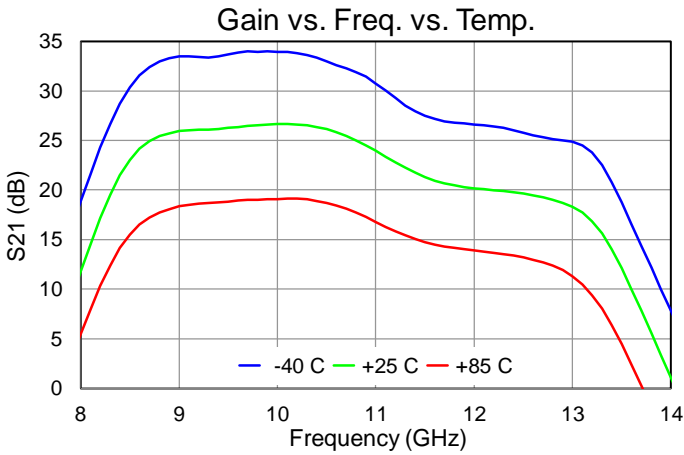

Performance Plots – Small Signal

Test conditions unless otherwise noted: T = 25 °C, V_D = 28 V, I_{DQ} = 2.0 A

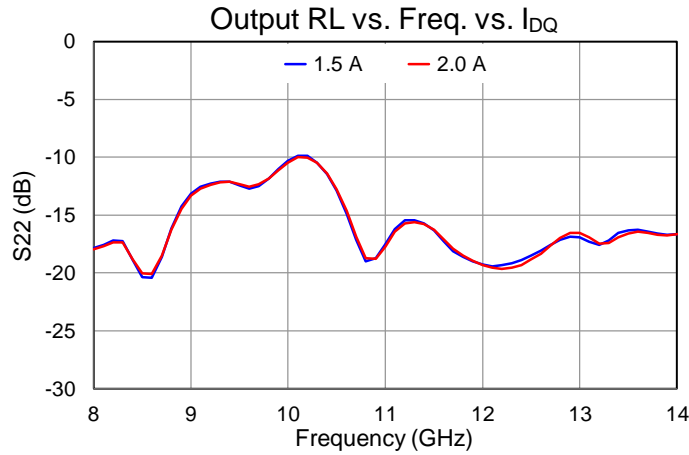
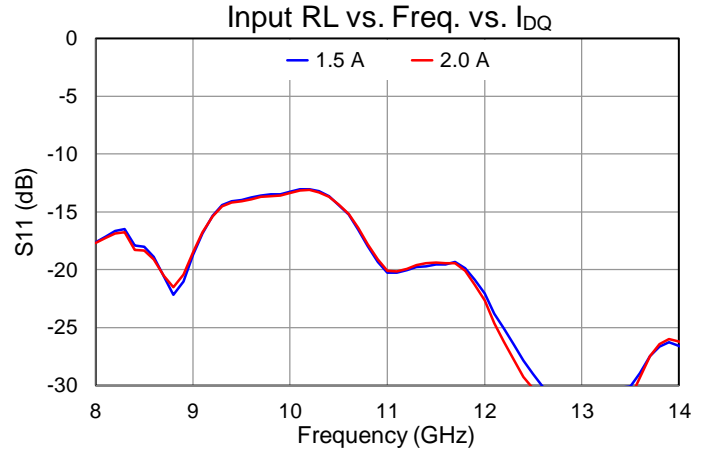
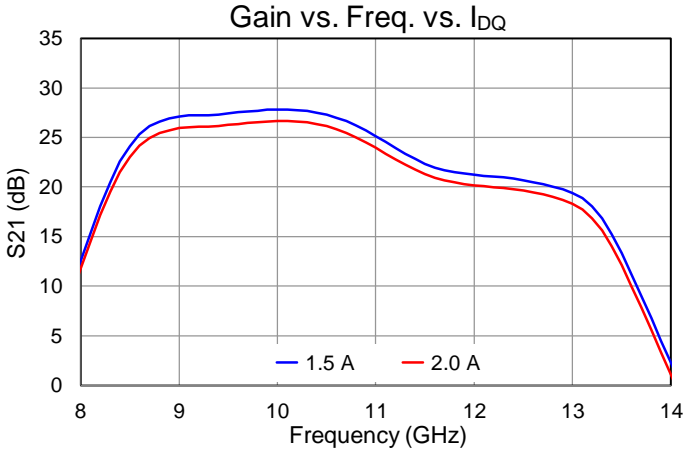

Thermal and Reliability Information

Parameter	Test Conditions	Value	Units
Thermal Resistance (θ_{JC}) ⁽¹⁾	$T_{BASE} = 85^{\circ}\text{C}$, $V_D = +28\text{ V}$, $I_{DQ} = 2.0\text{ A}$, $P_{DISS} = 56\text{ W}$	0.200	$^{\circ}\text{C}/\text{W}$
Channel Temperature, T_{CH} (No RF)		96.1	$^{\circ}\text{C}$
Thermal Resistance (θ_{JC}) ⁽¹⁾	$T_{BASE} = 85^{\circ}\text{C}$, $V_D = +28\text{ V}$, Freq = 12 GHz, $P_{IN} = 28\text{ dBm}$, $I_{DQ} = 2.0\text{ A}$, $I_{D_Drive} = 12.3\text{ A}$, $P_{OUT} = 48.8\text{ dBm}$, $P_{DISS} = 271.3\text{ W}$	0.258	$^{\circ}\text{C}/\text{W}$
Channel Temperature, T_{CH} (Under RF)		154.9	$^{\circ}\text{C}$
Thermal Resistance (θ_{JC}) ⁽¹⁾	$T_{BASE} = 85^{\circ}\text{C}$, $V_D = +28\text{ V}$, Freq = 12 GHz, $P_{IN} = 32\text{ dBm}$, $I_{DQ} = 2.0\text{ A}$, $I_{D_Drive} = 15.6\text{ A}$, $P_{OUT} = 50.1\text{ dBm}$, $P_{DISS} = 333.2\text{ W}$	0.264	$^{\circ}\text{C}/\text{W}$
Channel Temperature, T_{CH} (Under RF)		172.9	$^{\circ}\text{C}$

Notes:

1. Thermal resistance measured to back of package ($T = 85^{\circ}\text{C}$).
2. Refer to the following document: [GaN Device Channel Temperature, Thermal Resistance, and Reliability Estimates](#)

Gate Current and Dissipated Power

Test conditions unless otherwise noted: $T = 85^{\circ}\text{C}$, $I_{DQ} = 2.0\text{ A}$, $P_{IN} = 28\text{ dBm}$, $PW = 150\text{ us}$, Duty Cycle = 20%

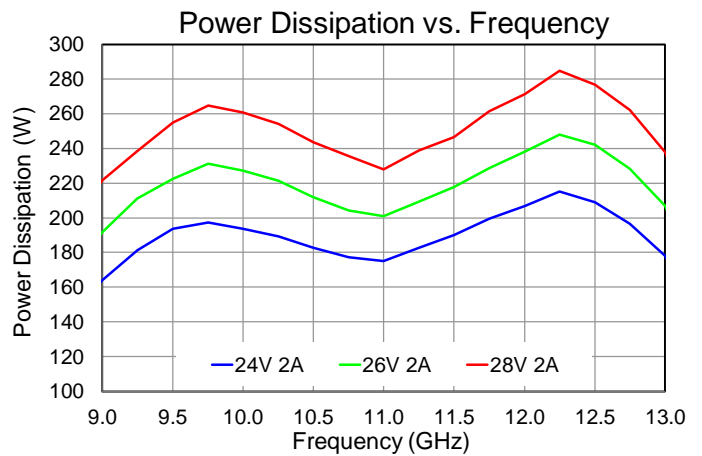
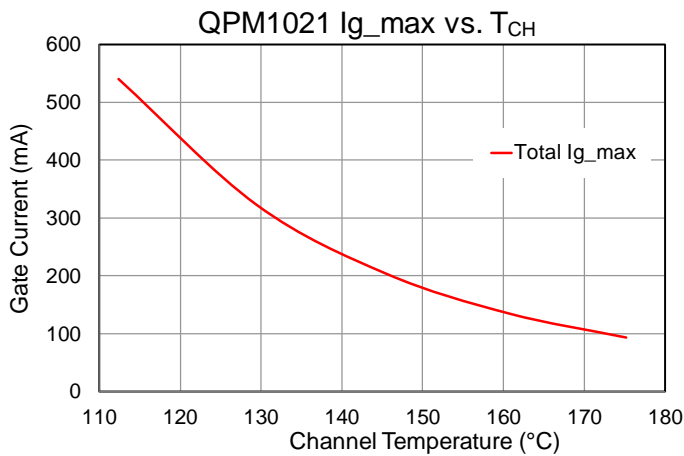

Applications Information

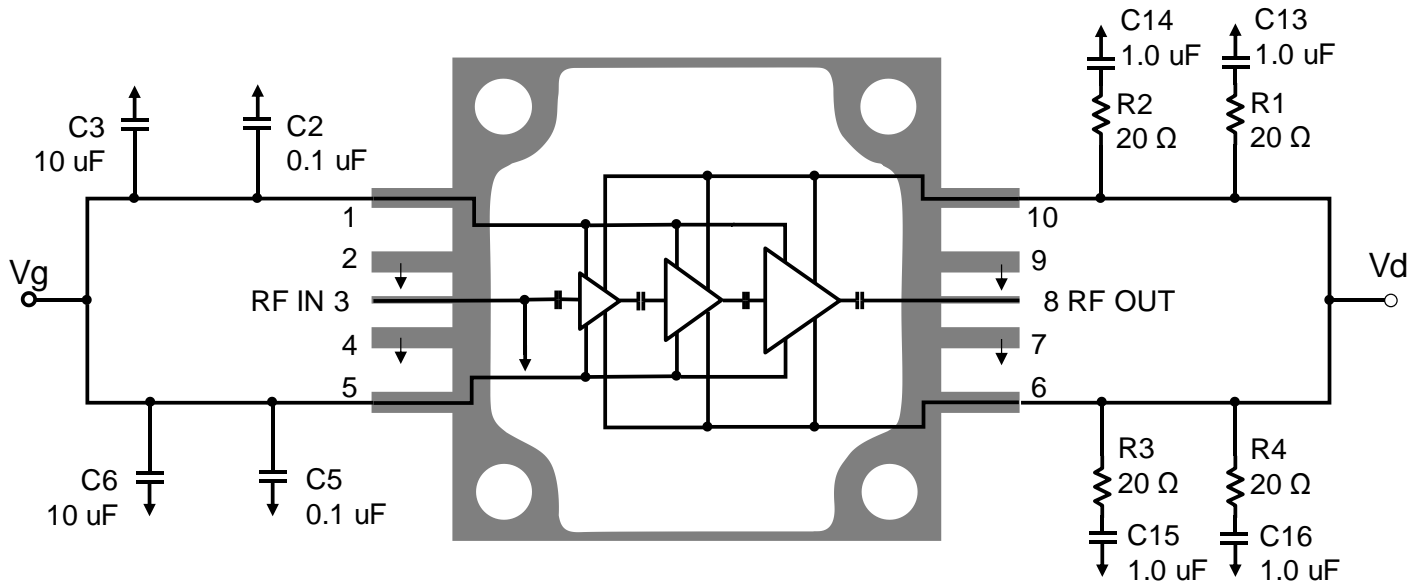

Notes:

1. V_G & V_D need to be biased from both sides.

Bias-Up Procedure

1. Set I_D limit to 17 A (peak), I_G limit to 60 mA
2. Set V_G to -5.0 V
3. Set V_D +28 V
4. Adjust V_G more positive until $I_{DQ} = 2.0$ A, peak
5. Apply RF signal

Bias-Down Procedure

1. Turn off RF signal
2. Reduce V_G to -5.0 V. Ensure $I_{DQ} \sim 0$ mA
4. Set V_D to 0 V
5. Turn off V_D supply
6. Turn off V_G supply

Evaluation Board (EVB) Layout Assembly

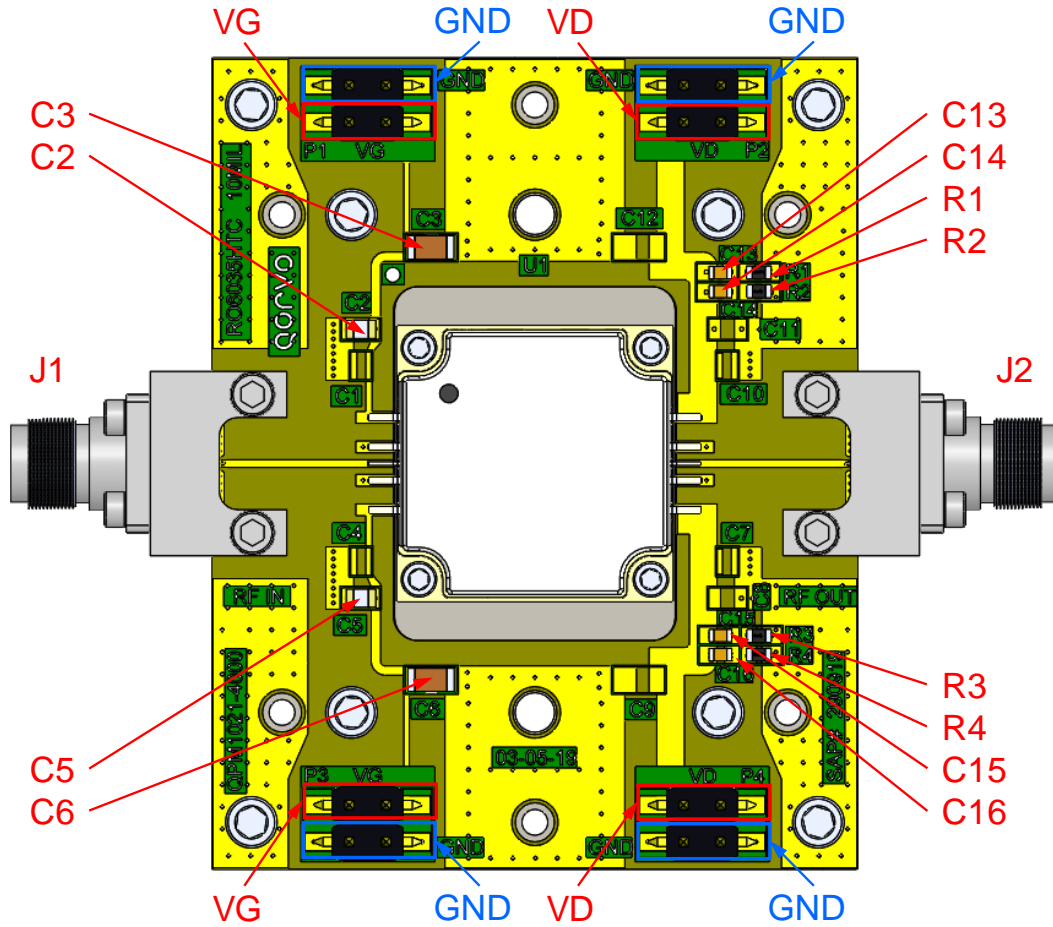

Bill of Materials

Reference Des.	Value	Description	Manuf.	Part Number
C3, C6	10 uF	CAP, CER, 10 uF, 50 V, 20%, X5R, 1206	Various	
C2, C5	0.1 uF	CAP, 0.1uF, 10%, 50V, X7R, 0805	Various	
C13, C14, C15, C16		CAP, 1uF, 10%, 50V, X7R, 0603	Various	
R1, R2, R3, R4	20 Ohm	RES 0603 20Ohms 200mW 1% -55 to +155C	Various	
J1, J2	2.92 mm	Female End Launch Connector	Southwest Microwave	1092-02A-5
PCB	-----	Rogers 6035HTC, 10 mil dielectric, 0.5 oz. copper (gold plated)	Rogers Corp.	

Mechanical Information and Bond Pad Description

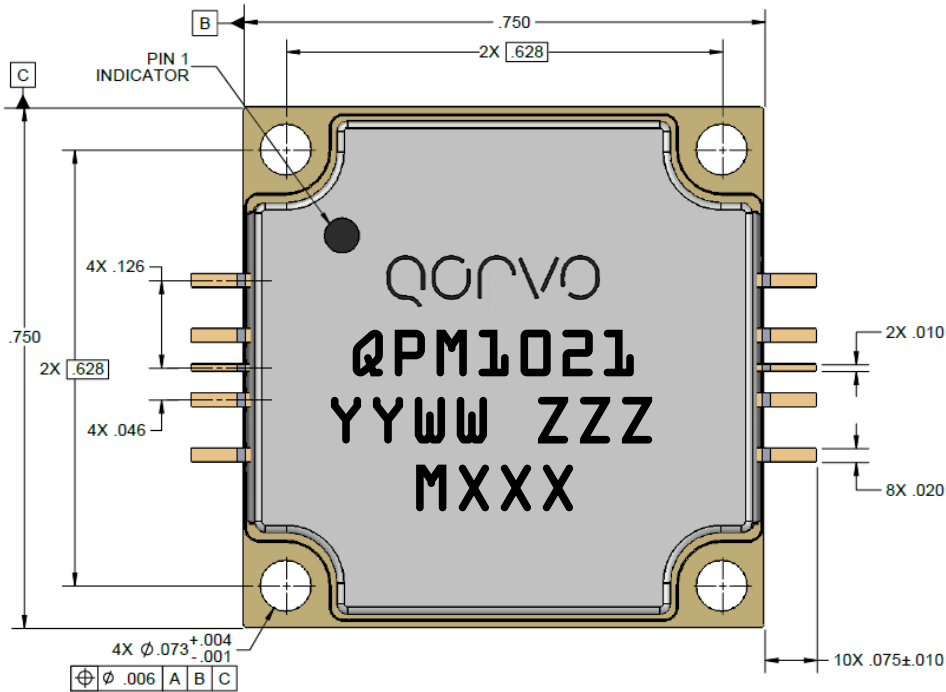

NOTES:

1. MATERIALS
PACKAGE BASE: COPPER
LEADS: ALLOY 194
LID: PLASTIC
FINISH: GOLD

2. PART IS EPOXY SEALED

3. UNITS: INCHES

4. TOLERANCES (UNLESS NOTED):
.XX = ± .01
.XXX = ± .005

5. MARKINGS
PART NUMBER: QPM1021
WORK YEAR: YY
WORK WEEK: WW
SERIAL NUMBER: ZZZ
BATCH ID: MXXX

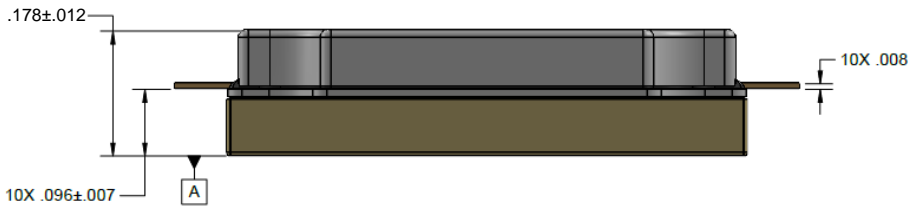

Package Lead Description

Pad No.	Symbol	Description
1, 5	V _G	Gate voltage. Bias network is required; see Application Circuit on page 12. Gate must be biased from both sides.
2, 4, 7, 9	Ground	Must be grounded to PCB
3	RF Input	RF Input; matched to 50 Ω, DC blocked, DC grounded
6, 10	V _D	Drain voltage. Bias network is required; see Application Circuit on page 12.
8	RF Output	RF Output; matched to 50 Ω, DC blocked

Assembly Notes

1. Carefully clean the PC board, base plate, and package leads with alcohol. Allow it to dry fully.
2. To improve the thermal and RF performance, Qorvo recommends attaching a heat sink to the bottom of the package and apply either a thermal compound (Arctic Silver 5 recommended) or a .004 inch (maximum thickness) Indium shim between the heat sink and the package. Refer to the applications note [Application of Arctic Silver 5 Thermal Compound and Indium Shims for Qorvo CP-style Packaged Components](#) for more information.
3. The component leads should be manually soldered. Apply a low residue solder alloy meeting J-STD-001 (ROLO, ROL1 or equivalent) with a liquidus temperature below 220 °C to each pin of the QPM1021. The use of low residue/no-clean flux (ROLO, ROL1) is recommended. The package lead temperature should not exceed 260 deg C. Each solder connection should be completed within 2 to 5 seconds. Adding flux during hand soldering of the component leads with localized spot cleaning is acceptable. Soldering irons meeting the requirements of J-STD-001, Appendix A are acceptable.
4. The leads should be soldered in a staggered or star pattern from side to side, and never solder two adjacent leads. This allows the heat to dissipate on each lead, and not cause the adjacent leads to become de-soldered and damaged or displaced.



5. The packaged part should not be subjected to conventional SMT automated solder reflow processes.
6. (The following is for information only. There are many variables in a second level assembly that Qorvo does not control, so Qorvo does not recommend an absolute torque value.) Use screws to attach the component to the heat sink. A suggested final torque value is 16 in-oz. for a 0-80 screw. Start with screws finger tight, then torque to 8 in-oz., then torque to final value. Use the following tightening pattern:

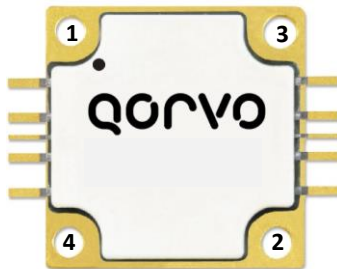

Handling Precautions

Parameter	Rating	Standard
ESD – Human Body Model (HBM)	1C	ESDA / JEDEC JS-001-2012
ESD – Charged Device Model (CDM)	C3	JEDEC JESD22-C101F
MSL – Moisture Sensitivity Level	NA	



Caution!
 ESD-Sensitive Device

Solderability

The component leads should be manually soldered, and the package cannot be subjected to conventional reflow processes. The use of no-clean solder to avoid washing after soldering is recommended.

RoHS Compliance

This part is compliant with 2011/65/EU RoHS directive (Restrictions on the Use of Certain Hazardous Substances in Electrical and Electronic Equipment) as amended by Directive 2015/863/EU.

This product also has the following attributes:

- Halogen Free (Chlorine, Bromine)
- Antimony Free
- TBBP-A (C₁₅H₁₂Br₄O₂) Free
- PFOS Free
- SVHC Free

Contact Information

For the latest specifications, additional product information, worldwide sales and distribution locations:

Web: www.qorvo.com

Tel: 1-844-890-8163

Email: customer.support@qorvo.com

Important Notice

The information contained in this Data Sheet and any associated documents (“Data Sheet Information”) is believed to be reliable; however, Qorvo makes no warranties regarding the Data Sheet Information and assumes no responsibility or liability whatsoever for the use of said information. All Data Sheet Information is subject to change without notice. Customers should obtain and verify the latest relevant Data Sheet Information before placing orders for Qorvo® products. Data Sheet Information or the use thereof does not grant, explicitly, implicitly or otherwise any rights or licenses to any third party with respect to patents or any other intellectual property whether with regard to such Data Sheet Information itself or anything described by such information.

DATA SHEET INFORMATION DOES NOT CONSTITUTE A WARRANTY WITH RESPECT TO THE PRODUCTS DESCRIBED HEREIN, AND QORVO HEREBY DISCLAIMS ANY AND ALL WARRANTIES WITH RESPECT TO SUCH PRODUCTS WHETHER EXPRESS OR IMPLIED BY LAW, COURSE OF DEALING, COURSE OF PERFORMANCE, USAGE OF TRADE OR OTHERWISE, INCLUDING THE IMPLIED WARRANTIES OF MERCHANTABILITY AND FITNESS FOR A PARTICULAR PURPOSE. Without limiting the generality of the foregoing, Qorvo® products are not warranted or authorized for use as critical components in medical, life-saving, or life-sustaining applications, or other applications where a failure would reasonably be expected to cause severe personal injury or death. Applications described in the Data Sheet Information are for illustrative purposes only. Customers are responsible for validating that a particular product described in the Data Sheet Information is suitable for use in a particular application.

© 2024 Qorvo US, Inc. All rights reserved. This document is subject to copyright laws in various jurisdictions worldwide and may not be reproduced or distributed, in whole or in part, without the express written consent of Qorvo US, Inc. | QORVO® is a registered trademark of Qorvo US, Inc.

Looking for pricing, stock, or lifecycle information?

Click below to explore more details on WIN SOURCE:

 [View QPM1021 on WIN SOURCE](#)

 [Qorvo US Inc. Information](#)

Optimize Your Supply Chain with WIN SOURCE Solutions

-  Global Sourcing Solution
-  Obsolete Management
-  Cost Control Management
-  Shortage Management
-  Alternative Solution
-  Excess Inventory Management