

Applications

- Commercial and Military Radar
- Communications

Product Features

- Frequency Range: 9 – 10 GHz
- P_{SAT} : 48 dBm
- PAE: 38%
- Small Signal Gain: 13 dB
- Bias: $V_D = 24$ V, $I_{DQ} = 2.4$ A, $V_G = -2.6$ V Typical
- Pulsed: PW = 100us, DC = 10%
- Integrated Thermistor Temperature Monitor
- Package Dimensions: 17.4 x 24.0 x 3.9 mm

General Description

TriQuint's TGA2312-FL is a high power amplifier operating between 9 and 10 GHz and typically providing 48dBm of saturated output power, 38% power-added efficiency and 13dB small signal gain.

Ideally suited for marine and weather radar, the TGA2312-FL is packaged in a CuW-base, flanged package for superior thermal management.

The TGA2312-FL uses TriQuint's 0.25um GaN on SiC technology which provides superior performance while maintaining high reliability. In addition, the use of SiC substrates provides optimum thermal performance necessary for reliable high power operation.

Lead-free and RoHS compliant.

Evaluation Boards are available upon request.

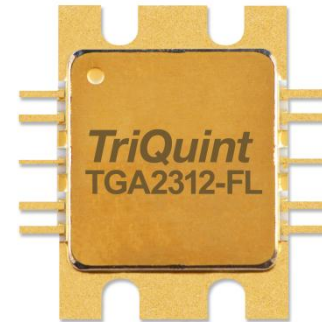

Functional Block Diagram

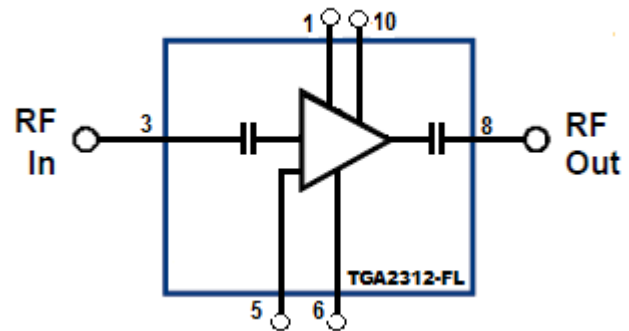

Pad Configuration

Pad No.	Symbol
1	V_G
2, 4, 7, 9	N/C
3	RF IN
5	Temp (Thermistor)
6	V_D
8	RF OUT
10	V_D

Ordering Information

Part	ECCN	Description
TGA2312-FL	3A001.b.3.b	GaN High Power Amplifier

Absolute Maximum Ratings

Parameter	Value
Drain Voltage (V_D)	40 V
Drain to Gate Voltage ($V_D - V_G$)	100 V
Gate Voltage Range (V_G)	-5 to 0 V
Drain Current (I_D)	10 A
Gate Current (I_G)	-25 to 56 mA
Power Dissipation (P_{DISS})	225 W
RF Input Power, CW, 50 Ω , $T = 25^\circ\text{C}$ (P_{IN})	+44 dBm
Channel Temperature (T_{CH})	275 $^\circ\text{C}$
Mounting Temperature (30 Seconds)	260 $^\circ\text{C}$
Storage Temperature	-40 to 150 $^\circ\text{C}$

Operation of this device outside the parameter ranges given above may cause permanent damage. These are stress ratings only, and functional operation of the device at these conditions is not implied.

Recommended Operating Conditions

Parameter	Value
Drain Voltage (V_D)	24 V
Drain Current (I_{DQ})	2400 mA
Drain Current Under RF Drive (I_{D_Drive})	6360 mA
Gate Voltage (V_G)	-2.6 V (Typ.)

Electrical specifications are measured at specified test conditions. Specifications are not guaranteed over all recommended operating conditions.

Electrical Specifications

Test conditions unless otherwise noted: 25 $^\circ\text{C}$, $V_D = 24\text{ V}$, $I_{DQ} = 2400\text{ mA}$, Pulsed: $PW = 100\mu\text{s}$, $DC = 10\%$, $V_G = -2.6\text{ V}$

Parameter	Min	Typical	Max	Units
Operational Frequency Range	9		10	GHz
Small Signal Gain		13		dB
Input Return Loss		15		dB
Output Return Loss		14		dB
Output Power at Saturation ($P_{in} = 38\text{ dBm}$)		48		dBm
Power-Added Efficiency ($P_{in} = 38\text{ dBm}$)		38		%
Output TOI		49		dBm
Gain Temperature Coefficient		-0.02		dB/ $^\circ\text{C}$
Power Temperature Coefficient		-0.001		dBm/ $^\circ\text{C}$
TOI Temperature Coefficient		-0.001		dBm/ $^\circ\text{C}$

Thermal and Reliability Information

Parameter	Test Conditions	Value	Units
Thermal Resistance, θ_{JC} (Note 1)	Tbaseplate = 85 °C	0.85	°C/W
Channel Temperature, T_{CH} (Without RF Drive)	Tbaseplate = 85 °C, $V_D = 24$ V, $I_{DQ} = 2400$ mA, $P_{DISS} = 58$ W, Pulsed: PW = 100us, DC = 10%	135	°C
Median Lifetime, T_M (Without RF Drive)		9.75×10^{10}	Hrs
Channel Temperature, T_{CH} (Under RF Drive)	Tbaseplate = 85 °C, $V_D = 24$ V, $I_{D_Drive} = 6360$ mA, $P_{OUT} = 48$ dBm, $P_{DISS} = 87$ W, Pulsed: PW = 100us, DC = 10%	158	°C
Median Lifetime, T_M (Under RF Drive)		7.38×10^9	Hrs
Channel Temperature, T_{CH} (Under RF Drive)	Tbaseplate = 85 °C, $V_D = 30$ V, $I_{D_Drive} = 6670$ mA, $P_{OUT} = 48.8$ dBm, $P_{DISS} = 124$ W, Pulsed: PW = 100us, DC = 10%	190	°C
Median Lifetime, T_M (Under RF Drive)		3.12×10^8	Hrs

Notes: (1) Thermal resistance measured at back of the package.

Median Lifetime

Test Conditions: $V_D = 40$ V; Failure Criteria is 10% reduction in I_{D_MAX}

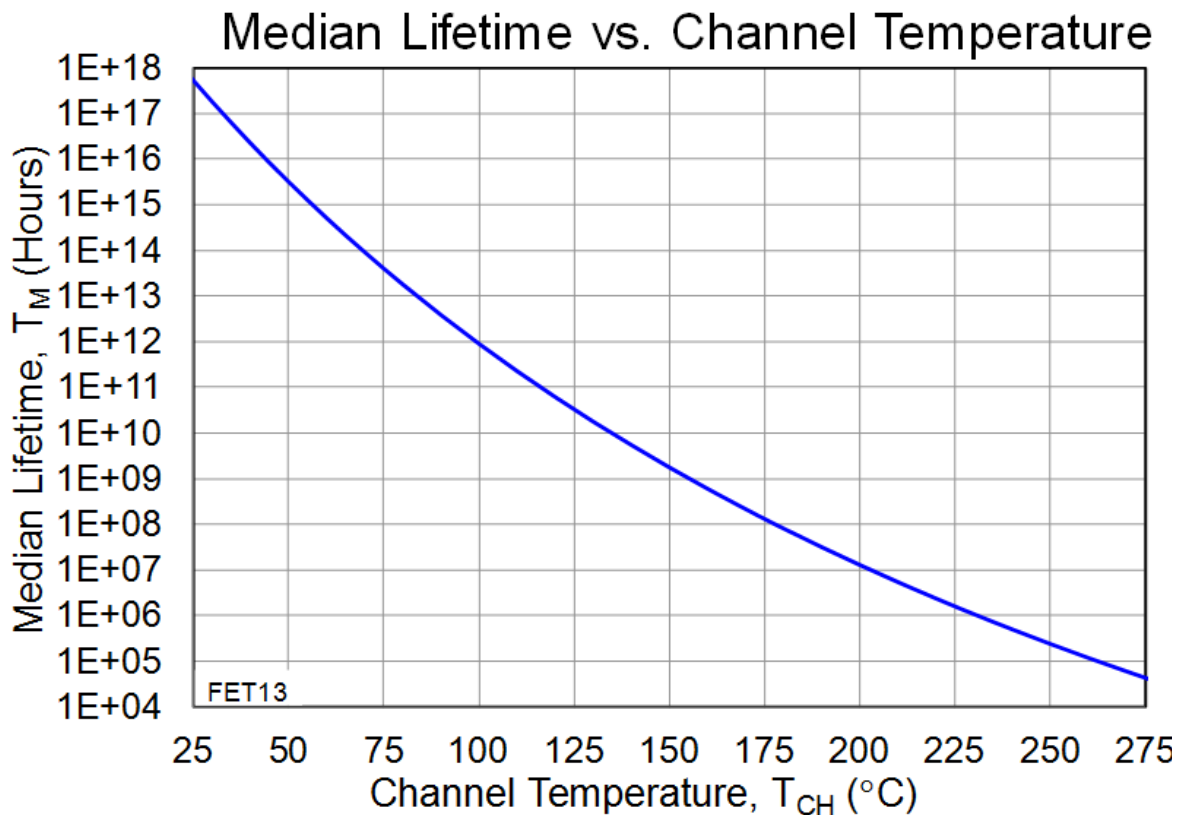

Typical Performance

Conditions unless otherwise specified: $V_D = 24\text{ V}$, $I_{DQ} = 2.4\text{ A}$, $V_G = -2.6\text{ V}$ Typical

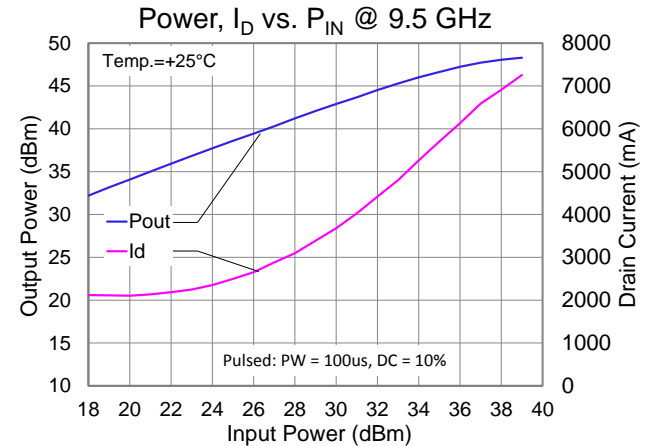
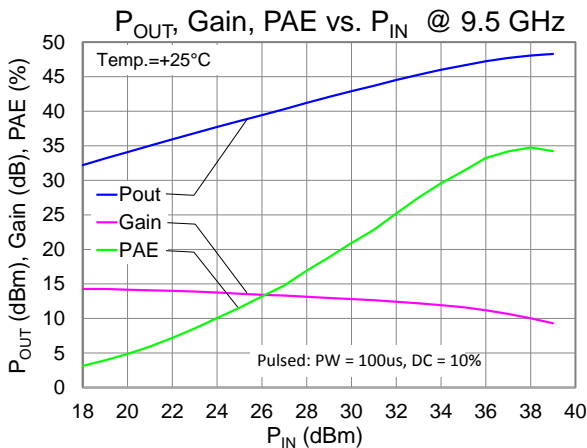
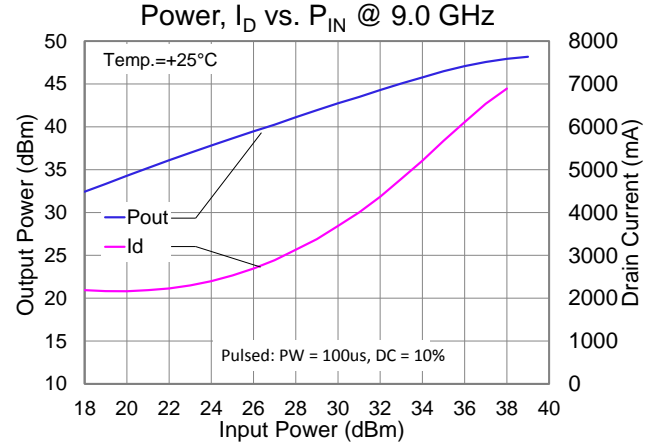
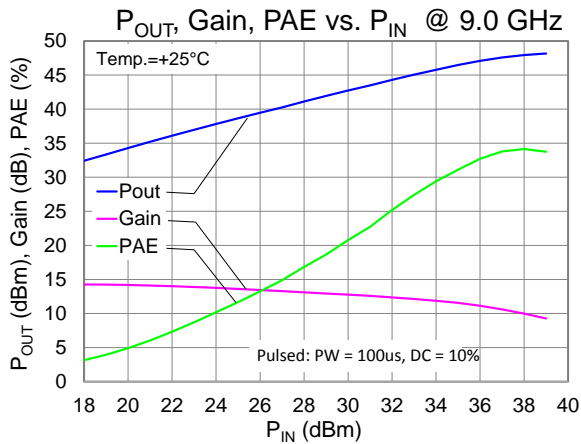
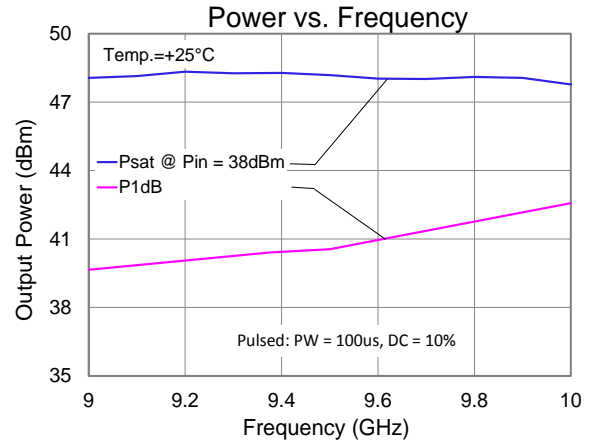
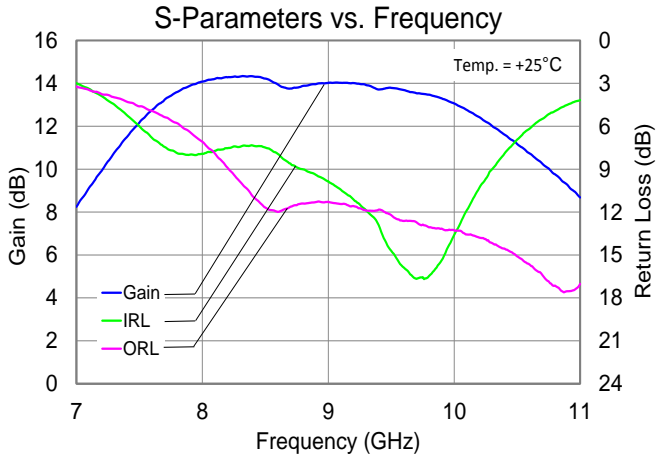

Typical Performance

Conditions unless otherwise specified: $V_D = 24\text{ V}$, $I_{DQ} = 2.4\text{ A}$, $V_G = -2.6\text{ V}$ Typical

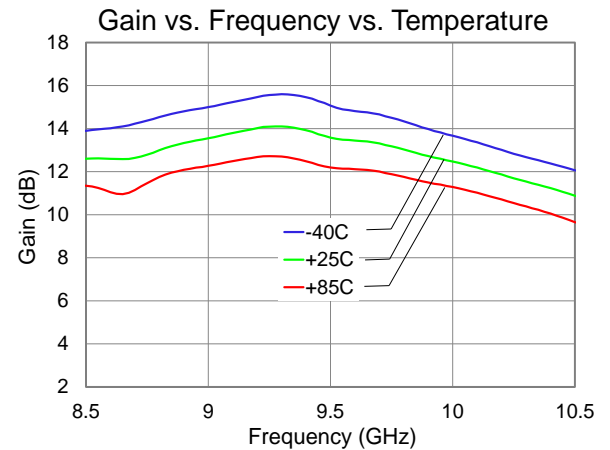
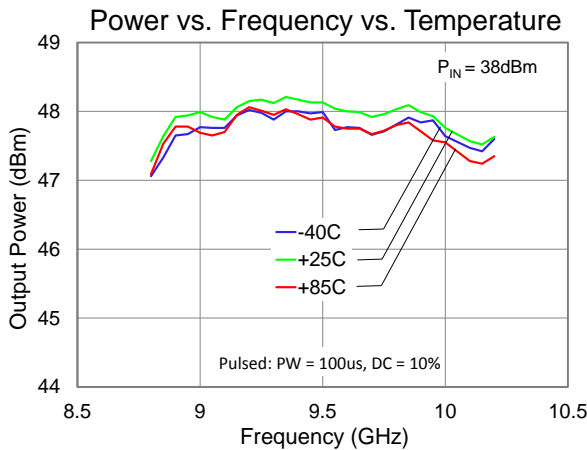
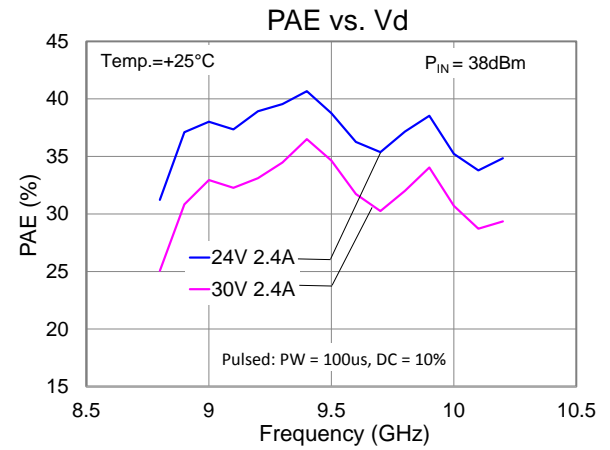
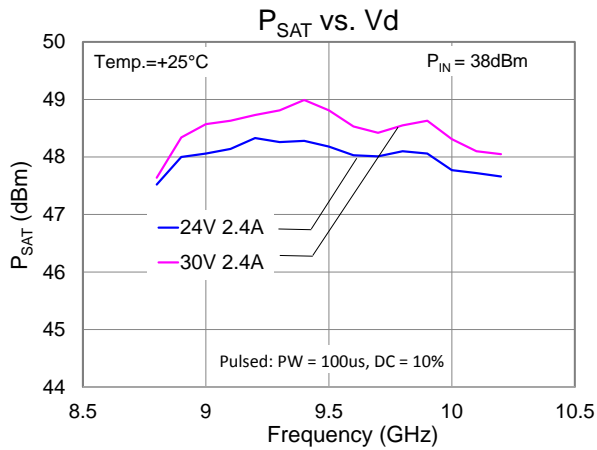
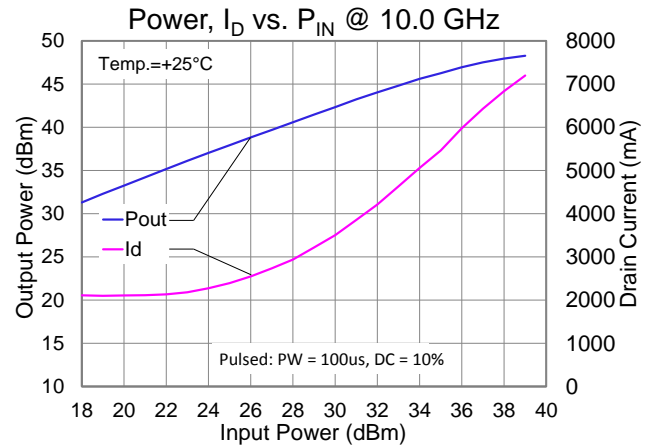
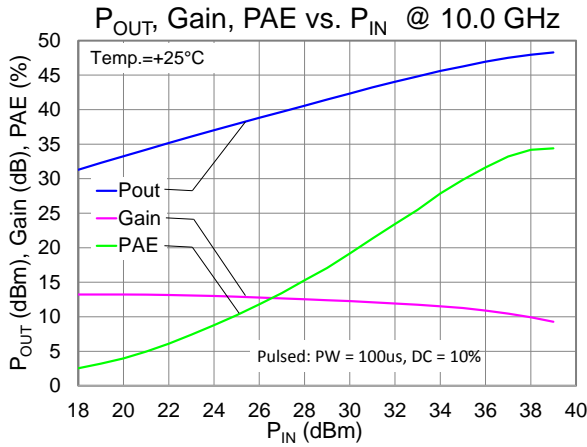

Typical Performance

Conditions unless otherwise specified: $V_D = 24\text{ V}$, $I_{DQ} = 2.4\text{ A}$, $V_G = -2.6\text{ V}$ Typical

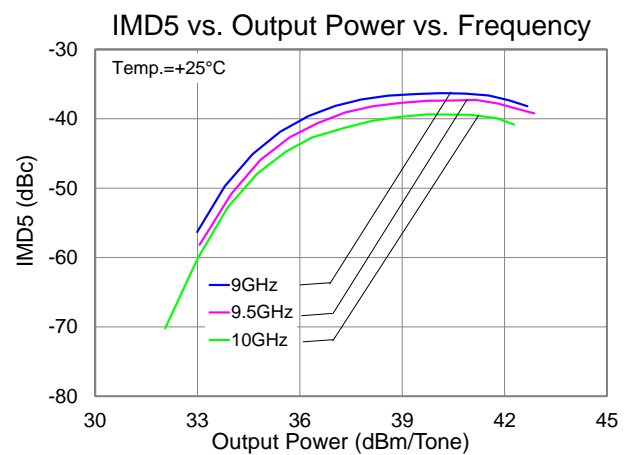
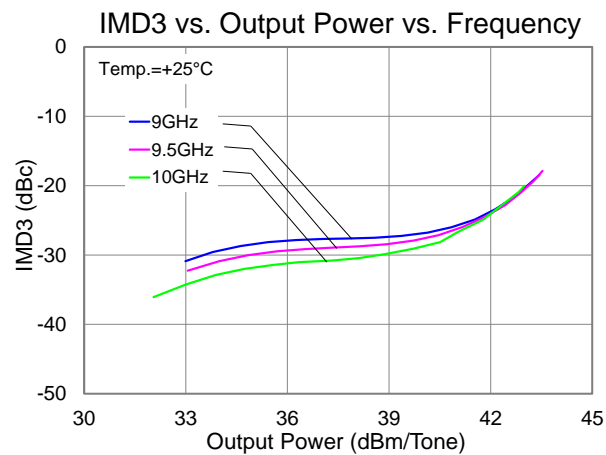
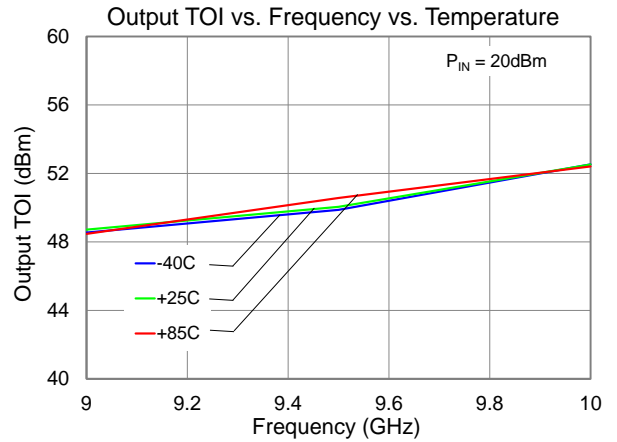
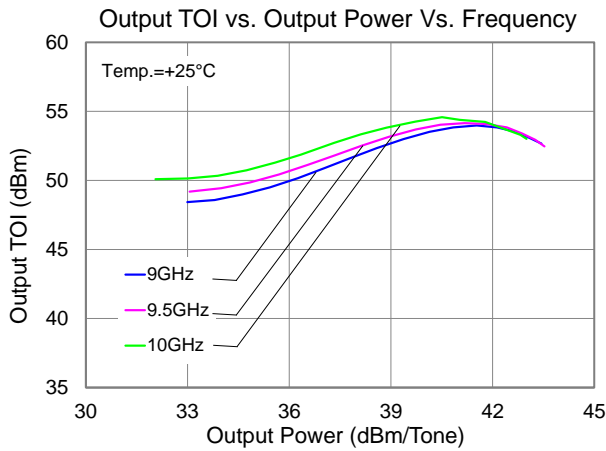

Typical Performance

A 100K Ω thermistor is assembled inside the TGA2312-FL package. Nominal resistance versus temperature is shown in the table below. The resistance measurement is taken between the Temp pin and ground pin to provide a useful indicator of the maximum package temperature.

deg C	R (Kohm)	deg C	R (Kohm)
0	378.80	65	17.89
5	284.71	70	14.84
10	216.16	75	12.37
15	165.70	80	10.37
20	128.17	85	8.74
25	100.00	90	7.40
30	78.66	95	6.29
35	62.36	100	5.37
40	49.81	105	4.61
45	40.06	110	3.96
50	32.44	115	3.43
55	26.44	120	2.97
60	21.68	125	2.59

Application Circuit

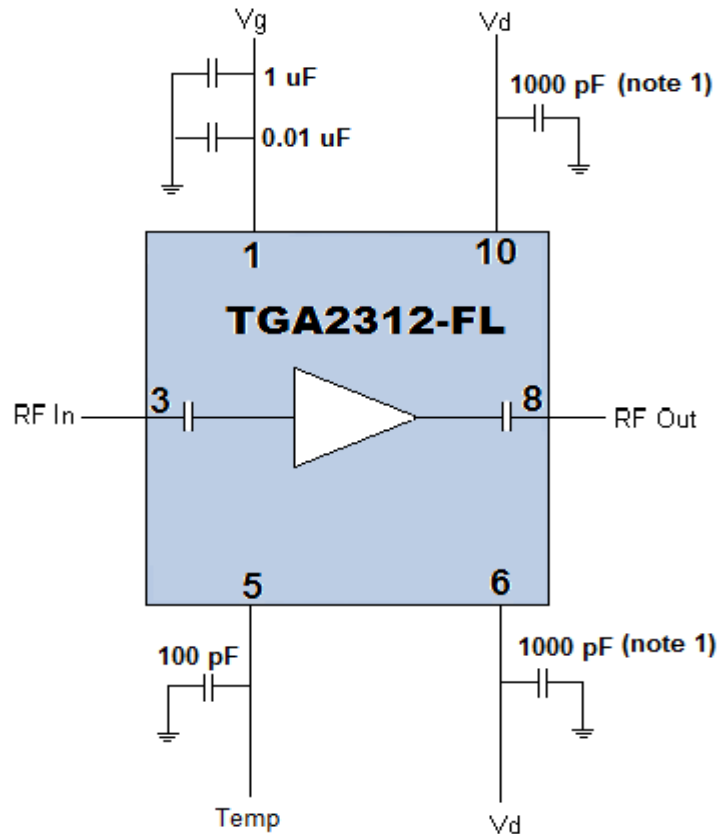

**Note 1: One of these caps can be removed for drain pulsing.
Drain voltage can be applied to either Vd pins.**

Notes: To prevent damage to the device due to overshoot or oscillation issues, TriQuint recommends that current limits for all power supplies are set properly for each power supply before applying the voltage. The following are recommended current limits for each power supply:

- Set 50 mA current limit to V_G .
- Set 8 A current limit to V_D .

Bias-up Procedure

1. Apply -5.0 V to V_G .
2. Apply +24 V to V_D .
3. Adjust V_G until $I_{DQ} = 2400$ mA ($V_G \sim -2.6$ V Typ.)
4. Turn on RF supply.

Bias-down Procedure

1. Turn off RF supply.
2. Reduce V_G to -5.0 V. Ensure $I_{DQ} \sim 0$ mA.
3. Set V_D to 0 V.
4. Set V_G to 0 V.

Recommended Board Layout Assembly

Top dielectric material is RO4350 0.020 inch thickness with 0.5 oz. copper.

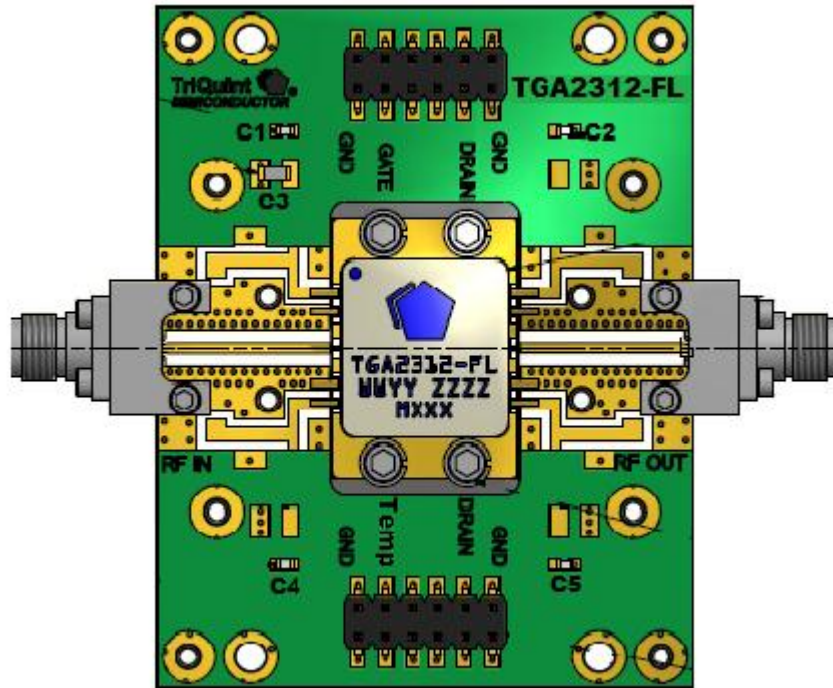

Bill of Materials

Reference Design	Value	Description	Manufacturer
C1	0.01 uF	Cap, 0603, 50V, 10%	Various
C2, C5	1000 pF	Cap, 0603, 50V, 5%	Various
C3	1.0 uF	Cap, 1206, 16V, 10%	Various
C4	100 pF	Cap, 0603, 50V, 5%	Various

Pin Layout

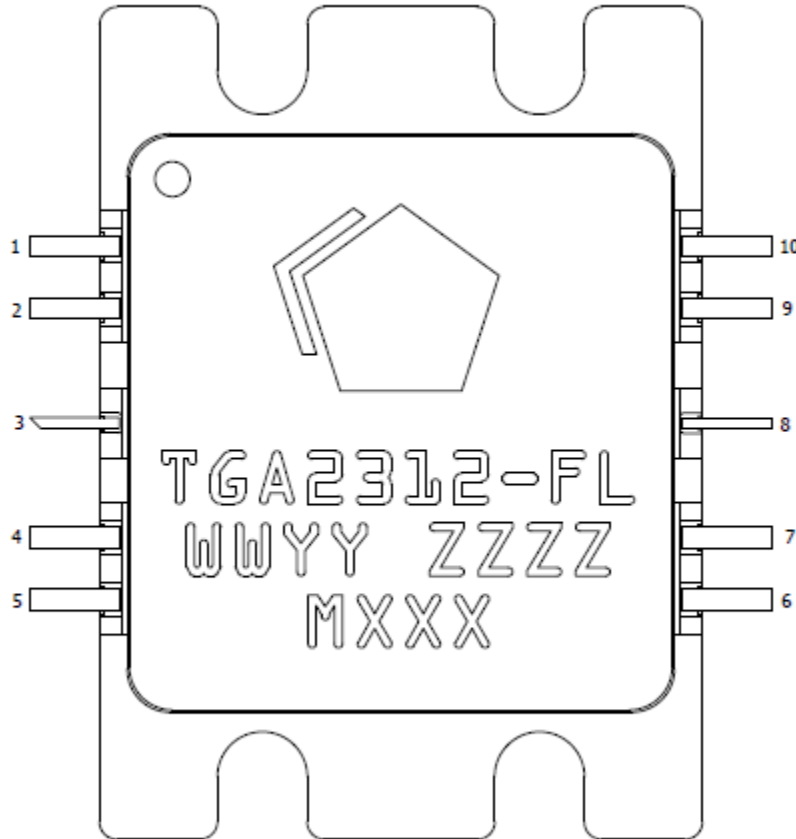

Pin Description

Pin	Symbol	Description
1	V_G	Gate voltage. Bias network is required. ⁽¹⁾
2, 4, 7, 9	N/C	No internal connection; must be grounded on PCB.
3	RF IN	RF input.
5	TEMP	Temperature sensing pin (Thermistor) ⁽²⁾
6	V_D	Bottom Drain voltage. Bias network is required. ⁽¹⁾
8	RF OUT	RF output.
10	V_D	Top Drain voltage Bias network is required. ⁽¹⁾

Notes:

1. See Application Circuit on page 8 as an example.
2. See page 7 for addition thermal information.

Mechanical Information

All dimensions are in inches. Unless specified otherwise.

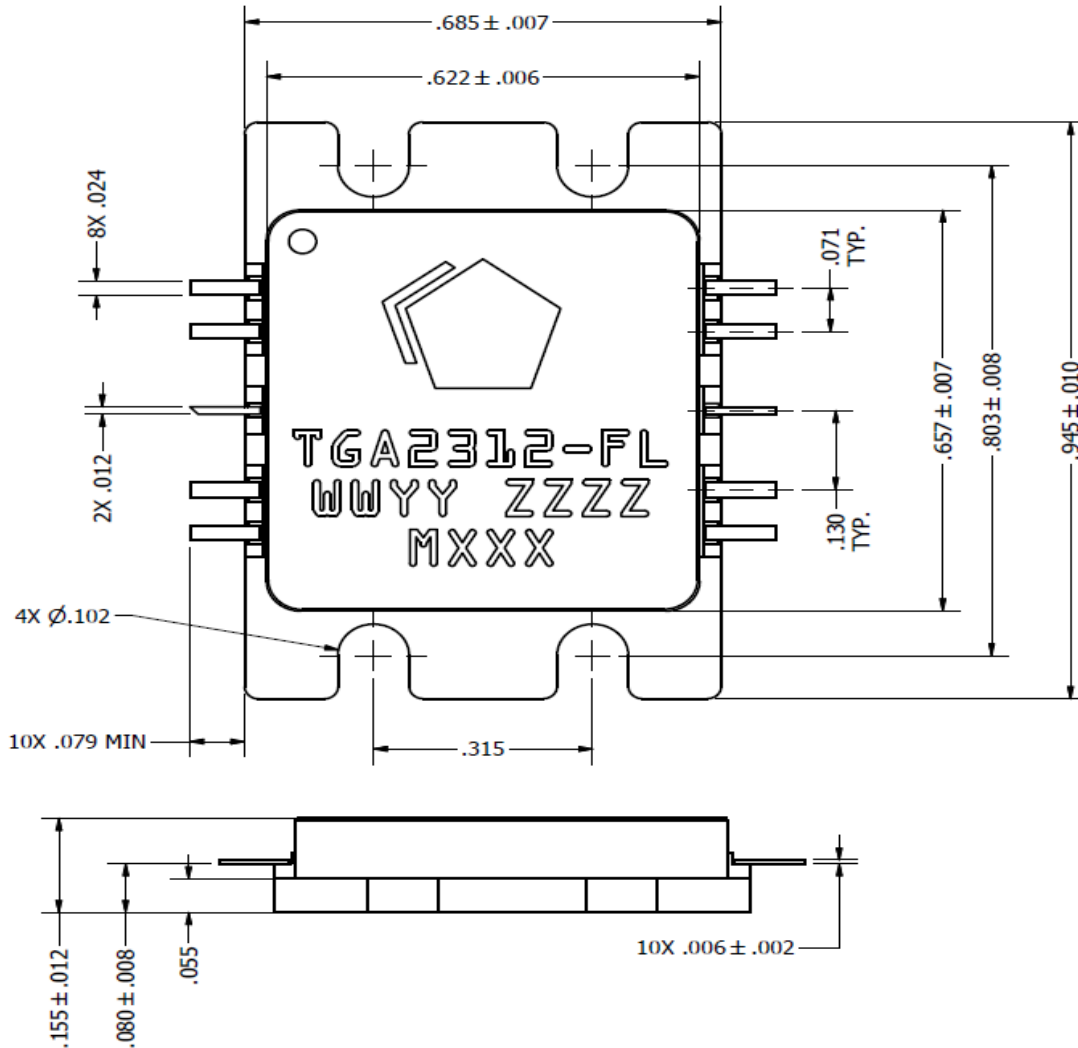

Marking: Part number – TGA2312-FL
 Week/Year code – WWYY
 Serial Number - ZZZZ
 Batch ID – MXXX

Package Materials:
 Base Copper Tungsten (CuW)
 Lead Copper Alloy 194
 Lid Kovar
 Plating Finish Gold Plating
 Part Is Hermetically Sealed

Assembly Notes

1. Clean the board or module with alcohol. Allow it to fully dry.
2. Nylock screws are recommended for mounting the TGA2312-FL to the board.
3. To improve the thermal and RF performance, we recommend the following:
 - a. Apply thermal compound or 4 mils indium shim between the package and the board.
 - b. Attach a heat sink to the bottom of the board and apply thermal compound or 4 mils indium shim between the heat sink and the board.
4. Apply solder to each pin of the TGA2312-FL.
5. Clean the assembly with alcohol.

Product Compliance Information**ESD Sensitivity Ratings**

Caution! ESD-Sensitive Device

ESD Rating: Class 1C
Value: 1800V
Test: Human Body Model (HBM)
Standard: JEDEC Standard JESD22-A114

MSL Rating

Level:: TBD

ECCN

US Department of Commerce: 3A001.b.3.b

RoHS Compliance

This part is compliant with EU 2002/95/EC RoHS directive (Restrictions on the Use of Certain Hazardous Substances in Electrical and Electronic Equipment).

This product also has the following attributes:

- Lead Free
- Halogen Free (Chlorine, Bromine)
- Antimony Free
- TBBP-A (C₁₅H₁₂Br₄O₂) Free
- PFOS Free
- SVHC Free

Contact Information

For the latest specifications, additional product information, worldwide sales and distribution locations, and information about TriQuint:

Web: www.triquint.com
Email: info-sales@triquint.com

Tel: +1.972.994.8465
Fax: +1.972.994.8504

For technical questions and application information: Email: info-products@triquint.com

Important Notice

The information contained herein is believed to be reliable. TriQuint makes no warranties regarding the information contained herein. TriQuint assumes no responsibility or liability whatsoever for any of the information contained herein. TriQuint assumes no responsibility or liability whatsoever for the use of the information contained herein. The information contained herein is provided "AS IS, WHERE IS" and with all faults, and the entire risk associated with such information is entirely with the user. All information contained herein is subject to change without notice. Customers should obtain and verify the latest relevant information before placing orders for TriQuint products. The information contained herein or any use of such information does not grant, explicitly or implicitly, to any party any patent rights, licenses, or any other intellectual property rights, whether with regard to such information itself or anything described by such information.

TriQuint products are not warranted or authorized for use as critical components in medical, life-saving, or life-sustaining applications, or other applications where a failure would reasonably be expected to cause severe personal injury or death.

Looking for pricing, stock, or lifecycle information?

Click below to explore more details on WIN SOURCE:

 [View TGA2312-FL on WIN SOURCE](#)

 [Qorvo US Inc. Information](#)

Optimize Your Supply Chain with WIN SOURCE Solutions

-  Global Sourcing Solution
-  Obsolete Management
-  Cost Control Management
-  Shortage Management
-  Alternative Solution
-  Excess Inventory Management