

3.5V - 38V / 3A / 0.85V - 6V Output

DESCRIPTION

The VDLM series Magl³C power module provides a fully integrated DC-DC power supply including the switching regulator with integrated MOSFETs, controller and compensation, as well as the shielded inductor in one package.

The 171033801 offers high efficiency and delivers up to 3A of output current. It operates with an input voltage from 3.5V to 38V and is designed for a small solution size.

The module maintains high efficiency throughout the output current range by automatically transitioning between operating modes based on the load demands.

The 171033801 is available in an LGA-12EP package (10 x 6 x 3.1mm).

This module has integrated protection circuitry that guards against thermal overstress with thermal shutdown and protects against electrical damage using overcurrent, output overvoltage, short circuit and undervoltage protections.

TYPICAL APPLICATIONS

- Point-of-Load DC-DC applications
- Industrial and medical applications
- Test and measurement applications
- DSPs, FPGAs, MCUs and MPUs supply
- I/O interface power supply

FEATURES

- Peak efficiency up to 96%
- Current capability up to 3A
- Input voltage range: 3.5V to 38V
- Output voltage range:
 - 0.85V to 13V at 2.5A
 - 0.85V to 6V at 3A
- 3.5μA typical quiescent current
- Integrated shielded inductor
- Adjustable switching frequency
- Current mode control
- Synchronous operation
- Undervoltage lockout
- Embedded soft-start
- Power good indicator
- Spread spectrum for optimized EMI performance
- Thermal shutdown
- Short circuit protection
- Overcurrent protection
- Output overvoltage protection
- Cycle-by-cycle current limit
- RoHS and REACH compliant
- Operating ambient temp. range: -40°C to 105°C
- Operating junction temp. range: -40°C to 125°C
- Complies with EN55032 class B conducted and radiated emissions standard

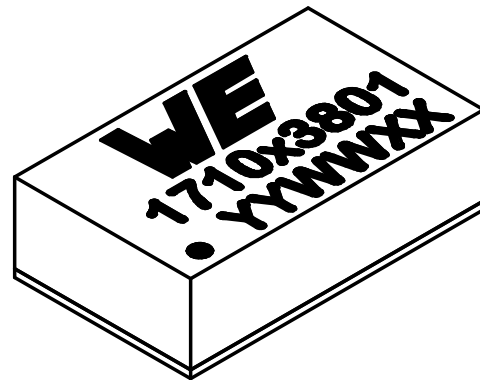

TYPICAL CIRCUIT DIAGRAM

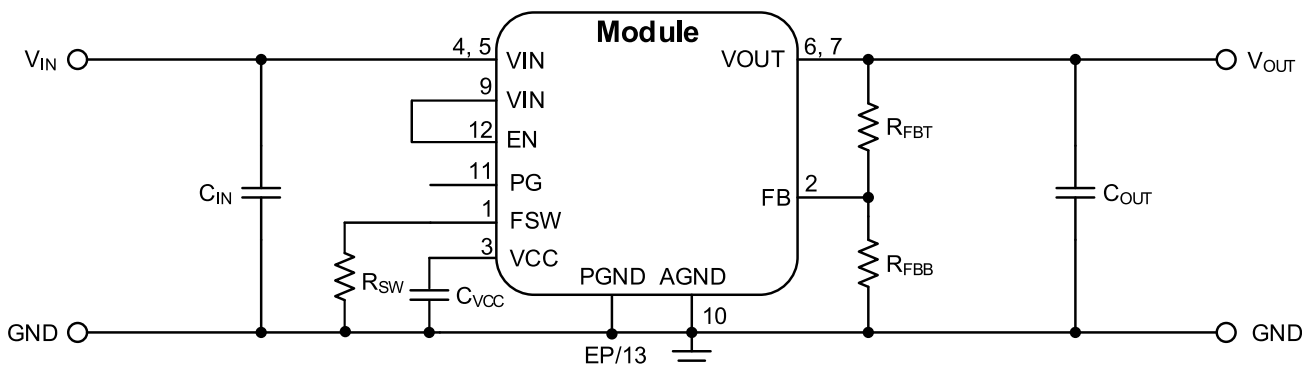

CONTENTS

1	PINOUT	4
2	ORDERING INFORMATION	5
3	PINOUT COMPATIBLE FAMILY MEMBERS	5
4	SALES INFORMATION	5
5	ABSOLUTE MAXIMUM RATINGS	6
6	OPERATING CONDITIONS	6
7	THERMAL SPECIFICATIONS	6
8	ELECTRICAL SPECIFICATIONS	7
9	RoHS, REACH	8
10	PACKAGE SPECIFICATIONS	8
11	NOTES	8
12	TYPICAL PERFORMANCE CURVES	9
12.1	Radiated and Conducted Emissions (With EMI Input Filter)	9
12.1.1	Radiated Emissions EN55032 (CISPR-32) Class B Complaint Test Setup	9
12.1.2	Conducted Emissions EN55032 (CISPR-32) Class B Complaint Test Setup	9
12.1.3	Radiated Emissions (Fixed Frequency)	10
12.1.4	Radiated Emissions (Spread Spectrum)	10
12.1.5	Conducted Emissions (Fixed Frequency)	11
12.1.6	Conducted Emissions (Spread Spectrum)	11
12.2	DC Performance Curves	12
12.2.1	Efficiency 12Vin	12
12.2.2	Efficiency 24Vin	12
12.2.3	Thermal Derating 12Vin	13
12.2.4	Thermal Derating 24Vin	13
12.2.5	Load Regulation 1.8Vout	14
12.2.6	Load Regulation 3.3Vout	14
12.2.7	Load Regulation 5Vout	15
12.2.8	Line Regulation 1.8Vout	15
12.2.9	Line Regulation 3.3Vout	16
12.2.10	Line Regulation 5Vout	16
13	BLOCK DIAGRAM	17
14	CIRCUIT DESCRIPTION	17
15	DESIGN FLOW	18
15.1	STEP 1 Set the Output Voltage (V_{OUT})	19
15.2	STEP 2 Select the Input Capacitor (C_{IN})	19
15.3	STEP 3 Select the Output Capacitor (C_{OUT})	19
15.4	STEP 4 Select the V_{CC} Capacitor (C_{VCC})	20
15.5	STEP 5 Select the Switching Frequency (f_{SW})	21
15.6	STEP 6 Optional: Set the Power Good Resistor	21
16	MODES OF OPERATION	21
17	OUTPUT VOLTAGE RIPPLE	22
17.1	PFM Operation	22

17.2 PWM Operation	22
18 PROTECTION FEATURES	23
18.1 Overcurrent Protection (OCP) and Short Circuit Protection (SCP)	23
18.2 Output Overvoltage Protection (OVP)	25
18.3 Over Temperature Protection (OTP)	25
18.4 Soft-Start	25
18.5 Enable and Integrated/Adjustable UVLO	25
19 DESIGN EXAMPLE	27
19.1 Layout	27
19.2 Schematic	28
19.3 Bill of Materials	28
20 HANDLING RECOMMENDATIONS	29
21 SOLDER PROFILE	29
22 PHYSICAL DIMENSIONS	30
22.1 Component	30
22.2 Example Landpattern Design	31
22.3 Tape	32
22.4 Reel	33
23 DOCUMENT HISTORY	34
24 LIST OF FIGURES	35
25 LIST OF TABLES	36
26 CAUTIONS AND WARNINGS	37
27 IMPORTANT NOTES	38

1 PINOUT

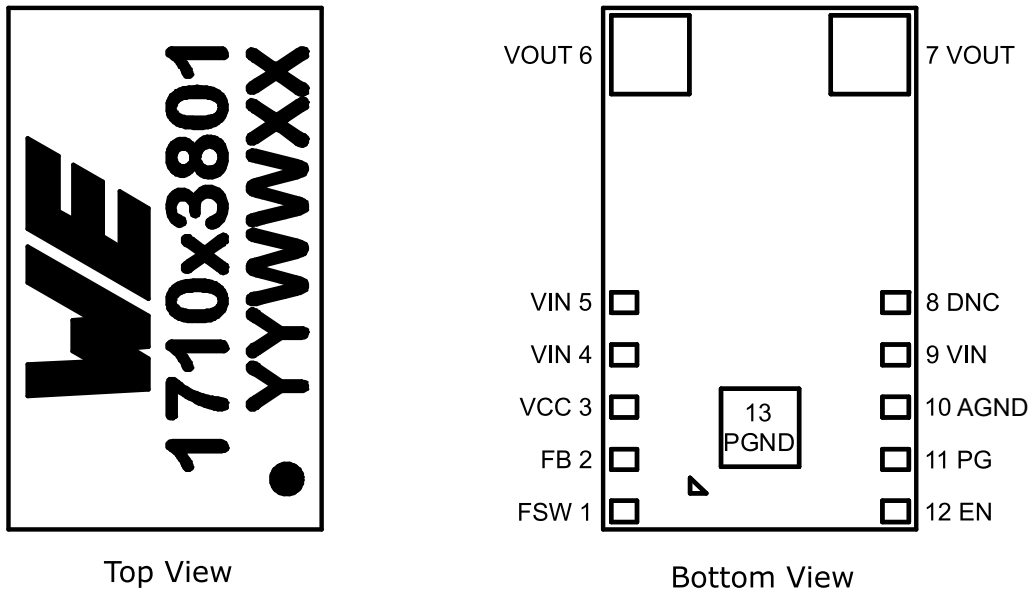

Figure 1: Pinout.

Table 1: Pin description.

SYMBOL	NUMBER	TYPE	DESCRIPTION
FSW	1	Input	Switching frequency selection pin. Connect an external resistor to select the switching frequency. The resistor can be connected to AGND to disable spread spectrum. The resistor can be connected to VCC to enable spread spectrum.
FB	2	Input	Feedback pin to the internal error amplifier. This pin must be connected to the external resistor divider to adjust the output voltage.
VCC	3	Power	VCC pin. This pin is attached to the output of the internal LDO. Connect a ceramic capacitor of 1 μ F to VCC and AGND. VCC be attached to FSW using a series resistor, R_{SW} . It should not be used to power other application functions.
VIN	4, 5	Power	Input voltage pins. Used for input power supply connection. Place the input capacitor as close as possible to VIN and PGND.
VOUT	6, 7	Power	Output voltage pins. Place output capacitors as close as possible to VOUT and PGND. For thermal performance use copper plane(s) at this pin.
DNC	8		This pin must be left floating.
VIN	9	Power	Input voltage pin. Internally connected to VIN, can be used to supply PG and EN pin. No need to connect externally to VIN trace (pin 4 and pin 5).
AGND	10	Power	Analog ground pin. Use this pin as ground for FSW, VCC and PG pins.
PG	11	Output	Power good flag pin. This open drain output asserts low if the output voltage is out of regulation. A pull-up resistor of 1M Ω is required if this function is used.
EN	12	Input	Enable pin. This pin has an internal voltage divider that sets the internal UVLO value. Pull this pin down to AGND to disable the module.
PGND	13 (EP)	Power	Exposed Pad. This pin is internally connected to PGND. It is recommended to connect this pin to the ground plane(s) for heat dissipation.

2 ORDERING INFORMATION

Table 2: Ordering information.

ORDER CODE	SPECIFICATIONS	PACKAGE	PACKAGING UNIT
171033801	3A / 0.85V-13V Vout	LGA-12EP	13" Reel (1000 pieces)
178033801	3A / 0.85V-13V Vout	Eval Board	1 piece

3 PINOUT COMPATIBLE FAMILY MEMBERS

Pinout compatible parts are listed below. This indicates identical assembly landpatterns only. The designer must take care to ensure that different pin assignments and functions may exist between pinout compatible parts and they should not be assumed to be swappable without design changes.

Table 3: Pinout compatible family members.

ORDER CODE	SPECIFICATIONS	PACKAGE	PACKAGING UNIT
171013801	1A / 0.85V-13V Vout	LGA-12EP	13" Reel (1000 pieces)
171023801	2A / 0.85V-13V Vout	LGA-12EP	13" Reel (1000 pieces)
171013802	1A / 0.85V-13V Vout, FPWM	LGA-12EP	13" Reel (1000 pieces)
171023802	2A / 0.85V-13V Vout, FPWM	LGA-12EP	13" Reel (1000 pieces)
171033802	3A / 0.85V-6V Vout, FPWM	LGA-12EP	13" Reel (1000 pieces)

4 SALES INFORMATION

Table 4: Sales information.

SALES CONTACT
Würth Elektronik eiSos GmbH & Co. KG EMC and Inductive Solutions Max-Eyth-Str. 1 74638 Waldenburg Germany Tel. +49 (0) 7942 945 0 www.we-online.com/powermodules Technical support: powermodules@we-online.com

5 ABSOLUTE MAXIMUM RATINGS

Caution:

Exceeding the listed absolute maximum ratings may affect the device negatively and may cause permanent damage.

Table 5: Absolute maximum ratings.

SYMBOL	PARAMETER	LIMIT		UNIT
		MIN ⁽¹⁾	MAX ⁽¹⁾	
V _{IN}	Input pin voltage	-0.3	42	V
V _{OUT}	Output pin voltage	-0.3	V _{IN} +0.3	V
FB	Feedback pin voltage	-0.3	8	V
EN	Enable pin voltage	-0.3	V _{IN} +0.3	V
PG	Power good pin voltage	-0.3	V _{IN} +0.3	V
VCC	VCC pin voltage with V _{IN} from 3.7V to 38V	-0.3	4	V
	VCC pin voltage with V _{IN} from 3.5V to 3.7V	-0.3	V _{IN} +0.3	V
FSW	Switching frequency selection pin voltage	-0.3	V _{CC} +0.3	V
T _{storage}	Assembled, non-operating storage temperature	-40	125	°C
V _{ESD}	ESD voltage (HBM), all pins (C=100pF R=1.5kΩ) ⁽⁴⁾	-2	2	kV

6 OPERATING CONDITIONS

Operating conditions are conditions under which the device is intended to be functional. All values are referenced to GND. MIN and MAX limits are valid for the recommended ambient temperature range of -40 °C to 105 °C. Typical values represents statistically the utmost probable values at the following conditions: V_{IN} = 24V, V_{OUT} = 5V, C_{IN} = 2 x 4.7µF ceramic, C_{OUT} = 47µF ceramic, T_A = 25 °C unless otherwise noted.

Table 6: Operating conditions.

SYMBOL	PARAMETER	MIN ⁽¹⁾	TYP ⁽³⁾	MAX ⁽¹⁾	UNIT
V _{IN}	Input Voltage	3.5	-	38	V
V _{OUT}	Output Voltage (Maximum I _{OUT} = 2.5A)	0.85	-	13	V
	Output Voltage (Maximum I _{OUT} = 3A)	0.85	-	6	V
T _a	Ambient temperature range	-40	-	105 ⁽²⁾	°C
T _j	Junction temperature range	-40	-	125	°C
I _{OUT}	Output current (Maximum V _{OUT} = 6V)	-	-	3	A

7 THERMAL SPECIFICATIONS

Typical values represents statistically the utmost probable values at the following conditions: V_{IN} = 24V, V_{OUT} = 5V, C_{IN} = 2 x 4.7µF ceramic, C_{OUT} = 47µF ceramic, T_A = 25 °C unless otherwise noted.

Table 7: Thermal specifications.

SYMBOL	PARAMETER	TYP ⁽³⁾	UNIT
Θ _{JA}	Junction-to-ambient thermal resistance ⁽³⁾	34	K/W
Θ _{JC}	Junction-to-case (top) thermal resistance ⁽³⁾	17	K/W
T _{SD}	Thermal shutdown, rising	165	°C
	Thermal shutdown, hysteresis	30	°C

8 ELECTRICAL SPECIFICATIONS

MIN and MAX limits are valid for the recommended ambient temperature range of -40°C to 105°C . Typical values represents statistically the utmost probable values at the following conditions: $V_{\text{IN}} = 24\text{V}$, $V_{\text{OUT}} = 5\text{V}$, $C_{\text{IN}} = 2 \times 4.7\mu\text{F}$ ceramic, $C_{\text{OUT}} = 47\mu\text{F}$ ceramic, $T_{\text{A}} = 25^{\circ}\text{C}$ unless otherwise noted.

Table 8: Electrical specifications.

SYMBOL	PARAMETER	TEST CONDITIONS	MIN ⁽¹⁾	TYP ⁽³⁾	MAX ⁽¹⁾	UNIT
V_{UVLO}	V_{IN} rising threshold		2.3	—	3.3	V
	V_{IN} falling threshold		2.15	—	3.15	V
I_{OC}	Overcurrent limit	No slope contribution	—	4.6	—	A
I_{RC}	Reverse current limit	OVP or PFM	—	1.5	—	A
$T_{\text{ON_MIN}}$	Minimum on-time		—	75	—	ns
$T_{\text{OFF_MIN}}$	Minimum off-time		—	200	—	ns
Enable						
V_{EN}	Enable threshold	Rising	1.08	1.2	1.32	V
		Hysteresis	—	0.2	—	V
VCC Regulator						
V_{CC}	LDO output voltage		3	3.3	3.6	V
Input Quiescent, No Load and Shutdown Current						
I_{SD}	Shutdown current from V_{IN}	$V_{\text{EN}} = \text{GND}$	—	2	—	μA
I_{Q}	Quiescent current from V_{IN}	$V_{\text{OUT}} \leq 3.2\text{V}$, no switching	20	35	60	μA
		$V_{\text{OUT}} > 3.2\text{V}$, no switching	1	3.5	6	μA
$I_{\text{IN-NL}}$	No load input current	$V_{\text{OUT}} = 3.3\text{V}$	—	15.3	—	μA
Output Voltage						
V_{FB}	Voltage reference	$T_{\text{J}} = -40^{\circ}\text{C} \leq T_{\text{J}} \leq 125^{\circ}\text{C}$	0.842	0.85	0.858	V
V_{OVP}	V_{FB} overvoltage threshold		115	120	125	%
$V_{\text{OVP_Hys}}$	V_{FB} overvoltage hysteresis		1	2	6	%
Soft-Start						
t_{SS}	Soft-start time	Rising edge to V_{OUT} (nom.)	1	1.3	1.6	ms
Switching Frequency						
f_{SW}	Switching frequency		200	—	2200	kHz
Power Good						
V_{PG}	Power good V_{OUT} threshold	$T_{\text{J}} = -40^{\circ}\text{C} \leq T_{\text{J}} \leq 125^{\circ}\text{C}$	87	90	93	%
V_{PG}	Power good $V_{\text{OUT_H}}$ threshold	$T_{\text{J}} = -40^{\circ}\text{C} \leq T_{\text{J}} \leq 125^{\circ}\text{C}$	—	120	—	%
$V_{\text{PG_HYS}}$	Power good V_{OUT} threshold hysteresis		—	3	—	%
Efficiency						
η	Efficiency	$V_{\text{IN}} = 12\text{V}$, $V_{\text{OUT}} = 3.3\text{V}$, $I_{\text{OUT}} = 3\text{A}$	—	87	—	%
		$V_{\text{IN}} = 12\text{V}$, $V_{\text{OUT}} = 5\text{V}$, $I_{\text{OUT}} = 3\text{A}$	—	89	—	%
		$V_{\text{IN}} = 24\text{V}$, $V_{\text{OUT}} = 5\text{V}$, $I_{\text{OUT}} = 3\text{A}$	—	86	—	%

9 RoHS, REACH

Table 9: RoHS, REACH.

RoHS directive		Directive 2011/65/EU of the European Parliament and the Council of June 8th, 2011 on the restriction of the use of certain hazardous substances in electrical and electronic equipment.
REACH directive		Directive 1907/2006/EU of the European Parliament and the Council of June 1st, 2007 regarding the Registration, Evaluation, Authorization and Restriction of Chemicals (REACH).

10 PACKAGE SPECIFICATIONS

Table 10: Package Specifications

ITEM	PARAMETER	TYP ⁽³⁾	UNIT
Lead Finish	ENEPIG	-	-
Weight	-	0.78	g

11 NOTES

- (1) Min and Max limits are 100% production tested at 25°C. Limits over the operating temperature range are guaranteed through correlation using Statistical Quality Control (SQC) methods.
- (2) Measured without heatsink. Natural convection (0 - 20LFM / 0- 0.1m/s) on a 80 x 80mm four layer board, with 70µm (2 ounce) copper.
- (3) Typical numbers are valid at 25°C ambient temperature and represent statistically the utmost probable values assuming a Gaussian distribution.
- (4) The human body model is a 100pF capacitor discharged through a 1.5Ωk resistor into each pin. Test method is per JESD-22-114.
- (5) Dependent on ambient temperature; see [THERMAL DERATING](#).

12 TYPICAL PERFORMANCE CURVES

If not otherwise specified, the following conditions apply: $T_A = 25^\circ\text{C}$.

12.1 Radiated and Conducted Emissions (With EMI Input Filter)

The 171033801 power modules were tested in several EMC configurations to give more realistic information about implementation in the applications. The test setup is based on CISPR16 with the limit values of CISPR32. All measurements were performed with the layout and components shown in [DESIGN EXAMPLE](#).

12.1.1 Radiated Emissions EN55032 (CISPR-32) Class B Complaint Test Setup

- Measured in a Fully Anechoic Room (FAR) at 3m antenna distance.
- Input wire length: 160cm (80cm horizontal + 80cm vertical)
- Measurement output wire length: 100cm

12.1.2 Conducted Emissions EN55032 (CISPR-32) Class B Complaint Test Setup

- Measurement input wire length: 80cm
- Measurement output wire length: 100cm

12.1.3 Radiated Emissions (Fixed Frequency)

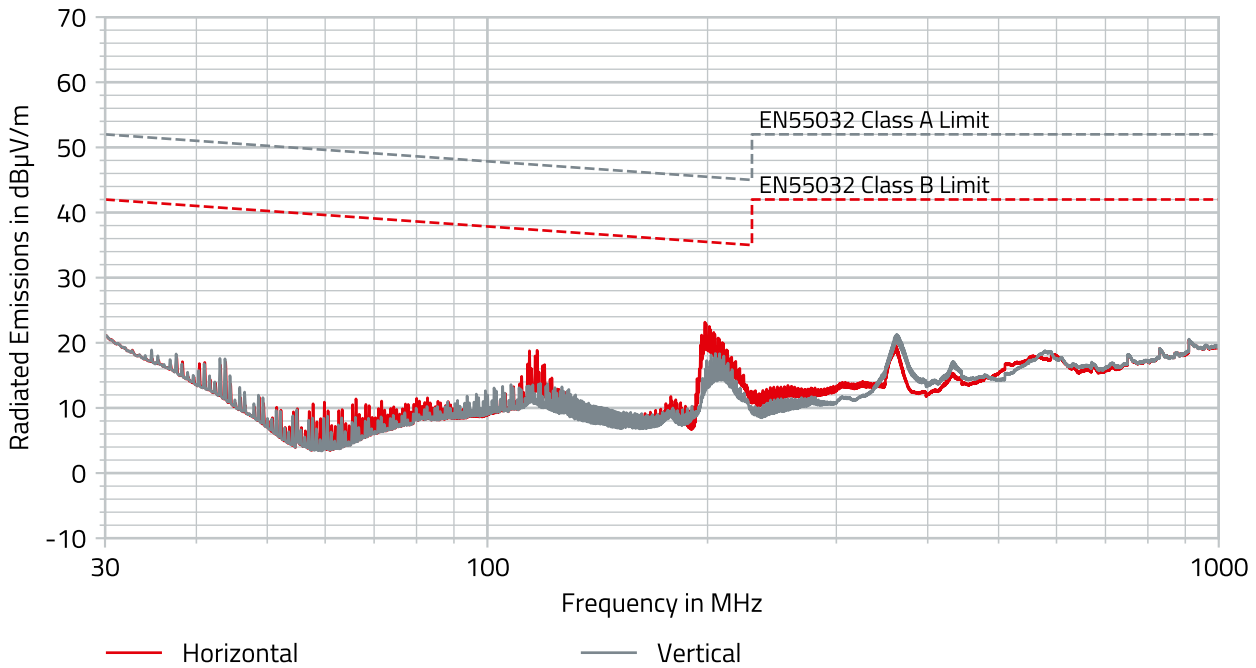

Figure 2: Radiated emissions (fixed frequency) 171033801 (3m antenna distance) $V_{IN} = 24V$, $V_{OUT} = 5V$, $I_{LOAD} = 3A$ with input filter

12.1.4 Radiated Emissions (Spread Spectrum)

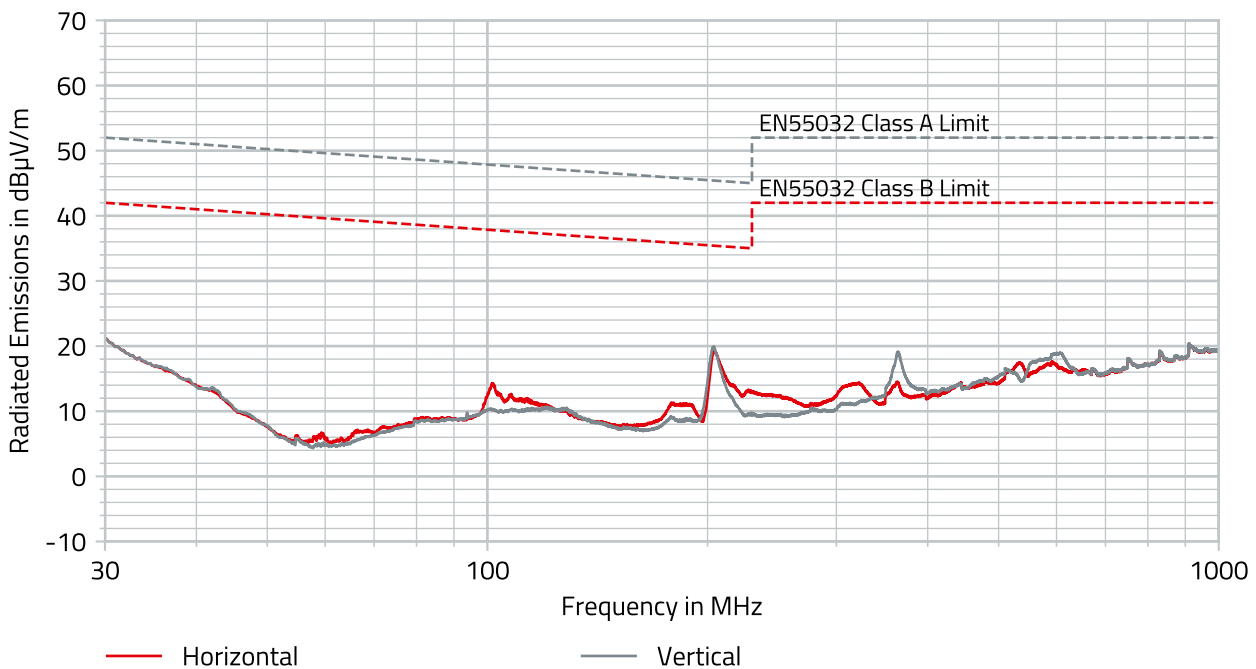

Figure 3: Radiated emissions (spread spectrum) 171033801 (3m antenna distance) $V_{IN} = 24V$, $V_{OUT} = 5V$, $I_{LOAD} = 3A$ with input filter.

12.1.5 Conducted Emissions (Fixed Frequency)

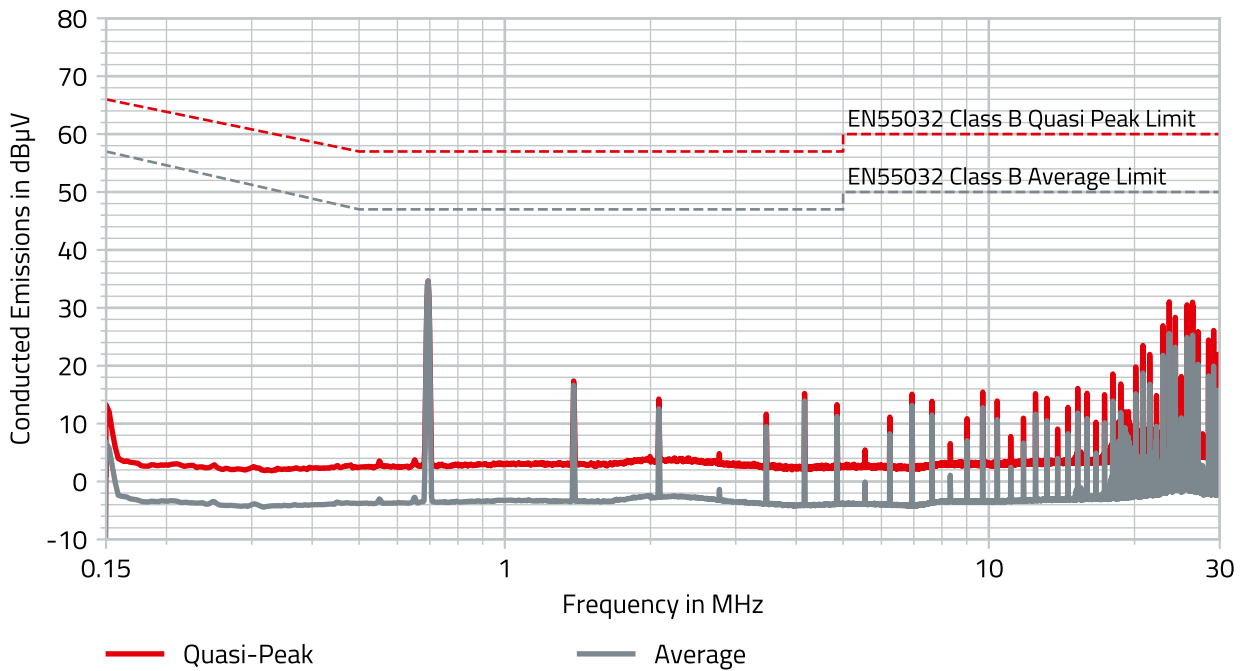

Figure 4: Conducted emissions (fixed frequency) 171033801 $V_{IN} = 24V$, $V_{OUT} = 5V$, $I_{LOAD} = 3A$ with input filter.

12.1.6 Conducted Emissions (Spread Spectrum)

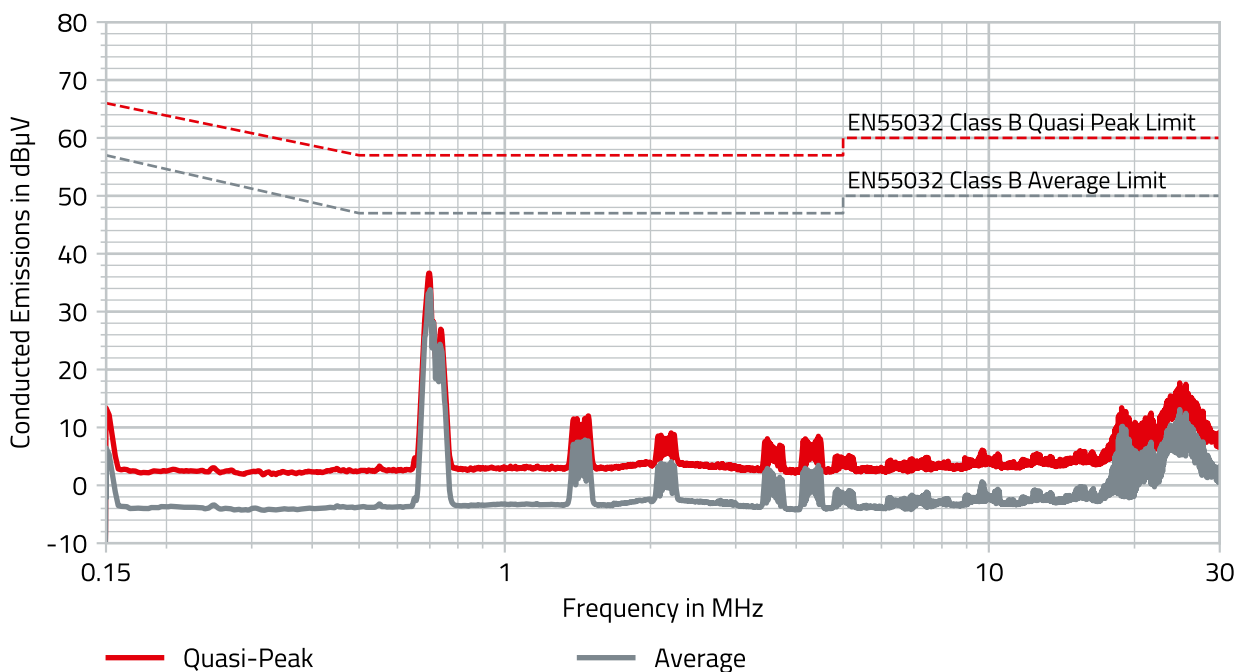

Figure 5: Conducted emissions (spread spectrum) 171033801 $V_{IN} = 24V$, $V_{OUT} = 5V$, $I_{LOAD} = 3A$ with input filter.

12.2 DC Performance Curves

12.2.1 Efficiency 12V_{IN}

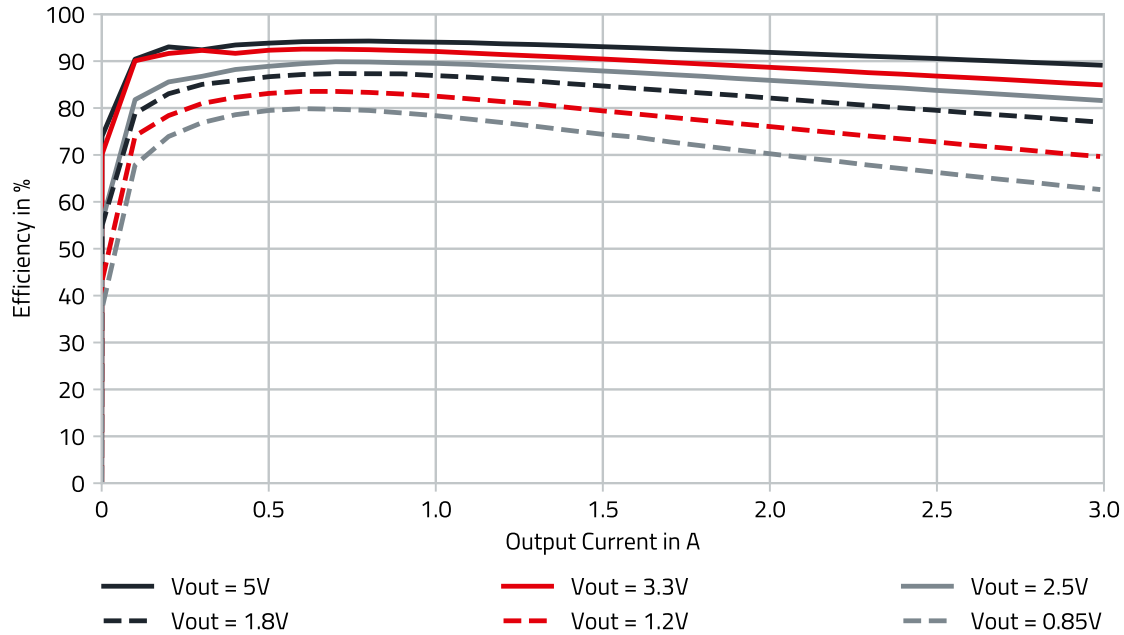

Figure 6: 171033801 efficiency V_{IN} = 12V.

12.2.2 Efficiency 24V_{IN}

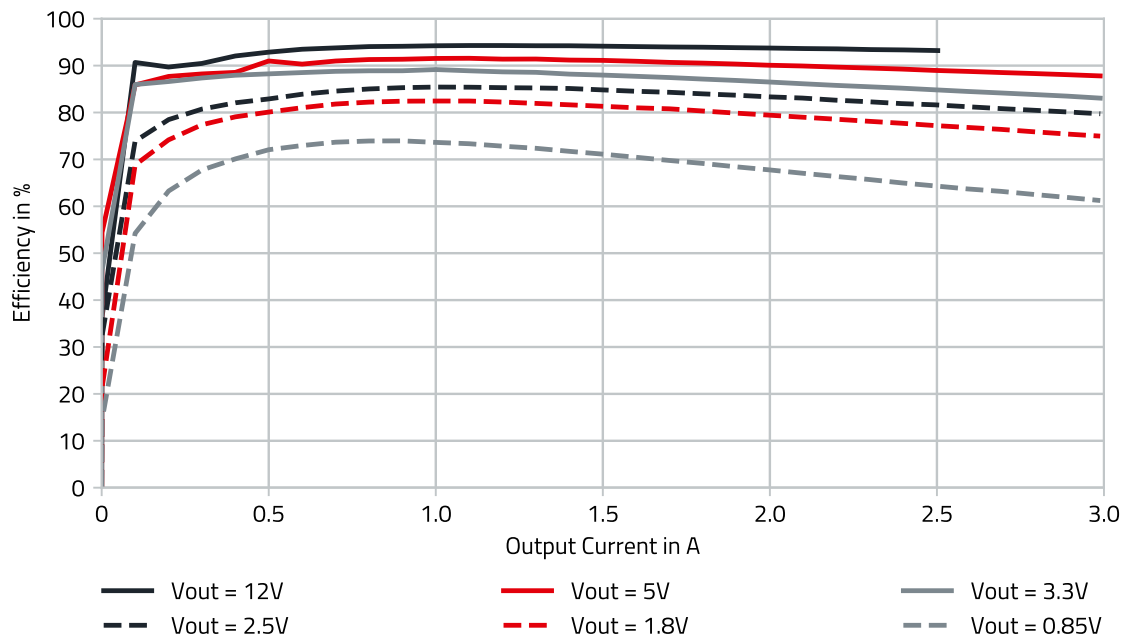

Figure 7: 171033801 efficiency V_{IN} = 24V.

12.2.3 Thermal Derating 12V_{IN}

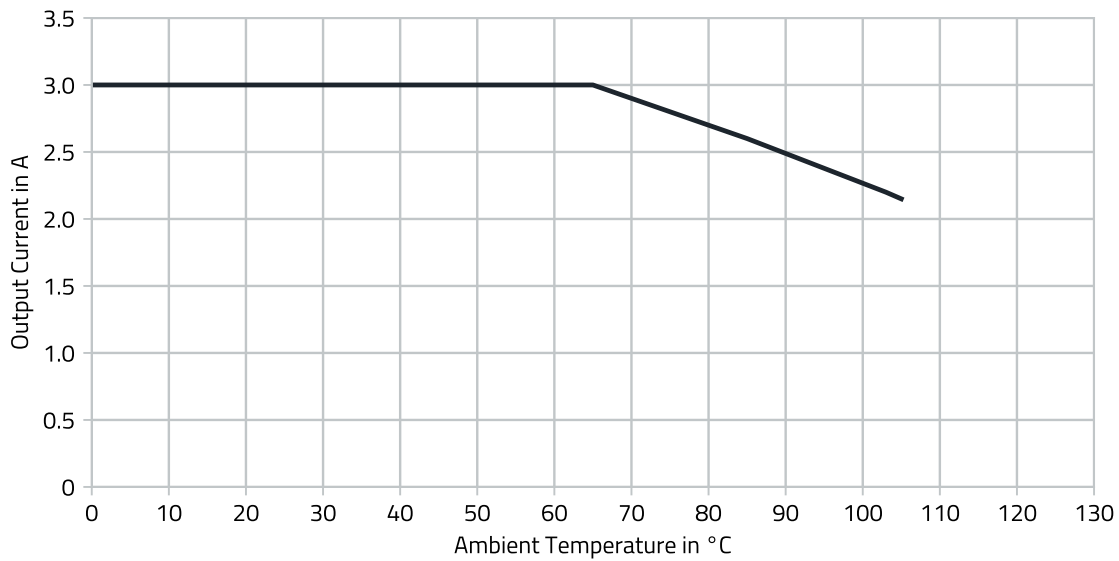

Figure 8: 171033801 output current thermal derating $V_{IN} = 12V$, $V_{OUT} = 5V$.

12.2.4 Thermal Derating 24V_{IN}

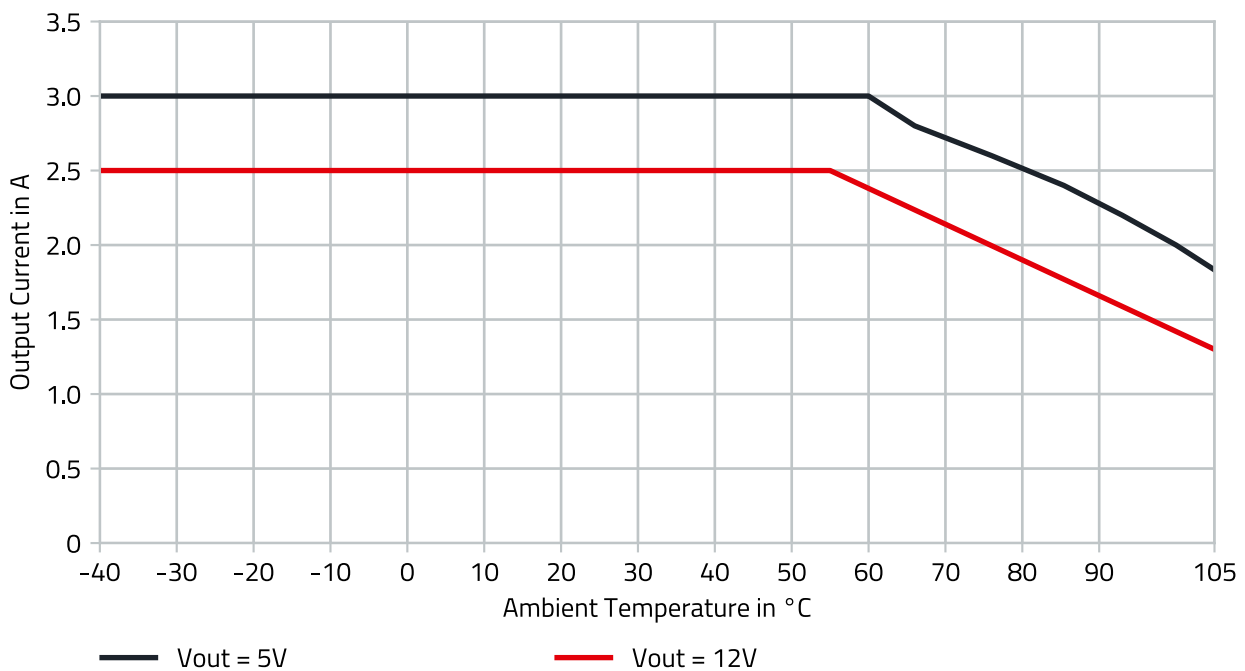

Figure 9: 171033801 output current thermal derating $V_{IN} = 24V$.

Note: Both thermal derating graphs were measured on the 178033801 Evaluation Board (80 x 80 mm, four layers, 70 μ m copper thickness). Please see T_A limits in [OPERATING CONDITIONS](#).

12.2.5 Load Regulation 1.8V_{OUT}

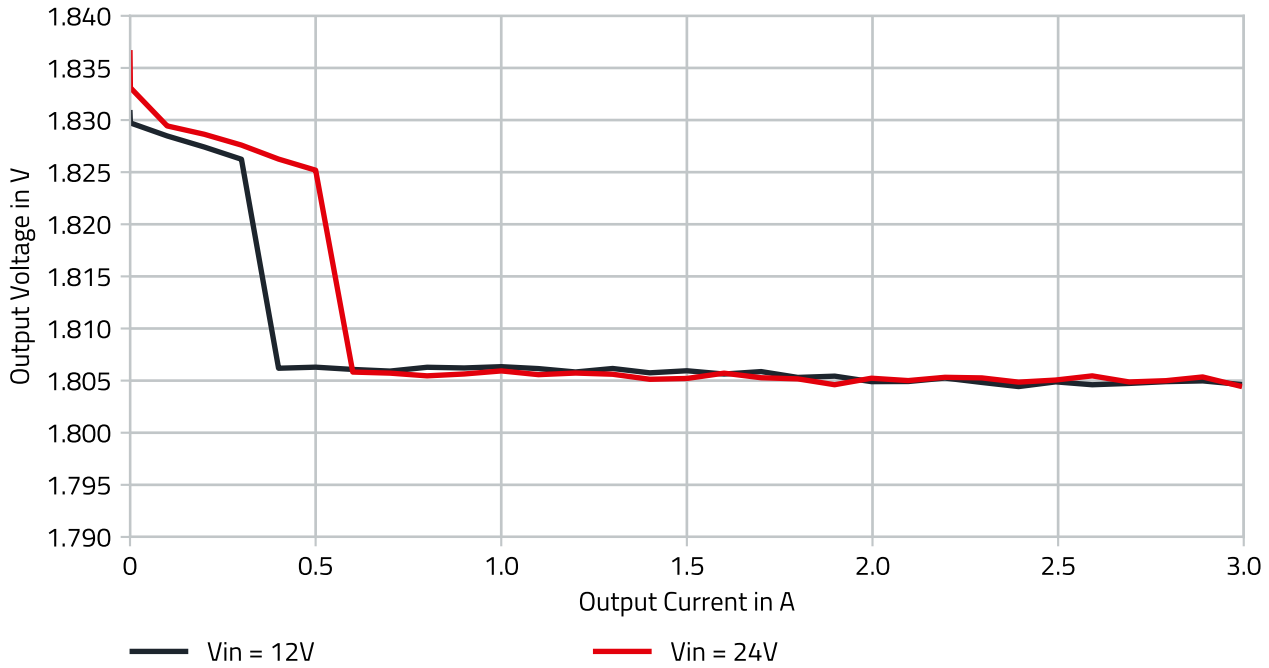

Figure 10: 171033801 Load Regulation $V_{OUT} = 1.8V$.

12.2.6 Load Regulation 3.3V_{OUT}

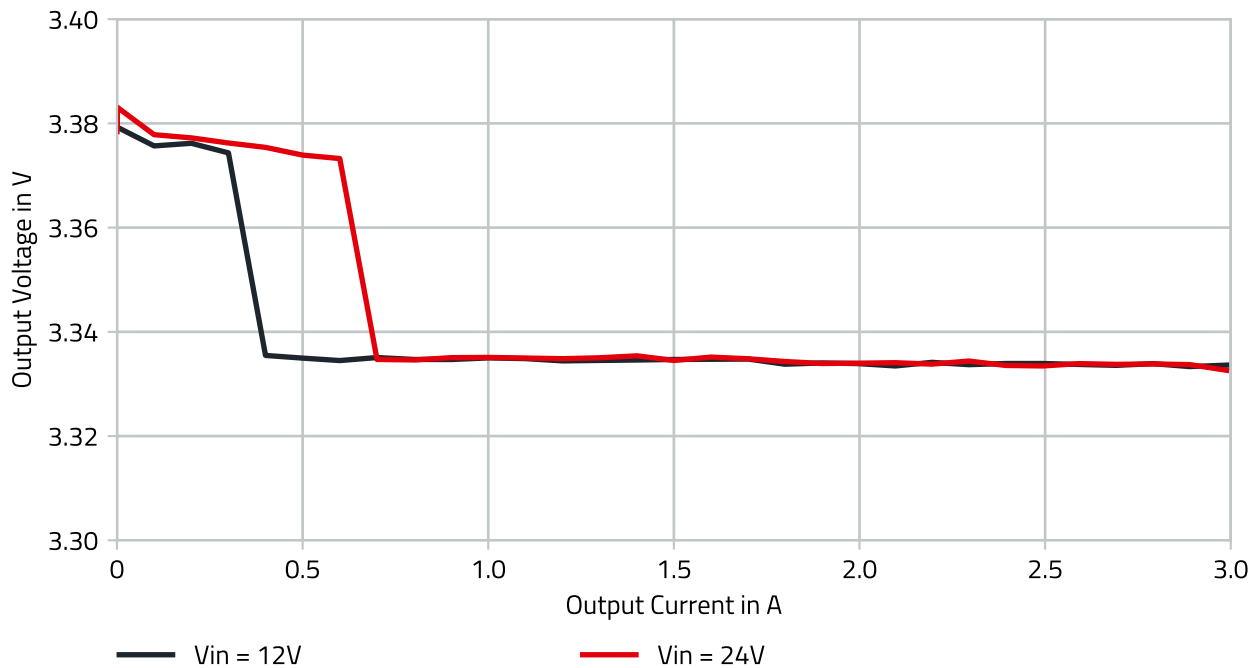

Figure 11: 171033801 Load Regulation $V_{OUT} = 3.3V$.

12.2.7 Load Regulation 5V_{OUT}

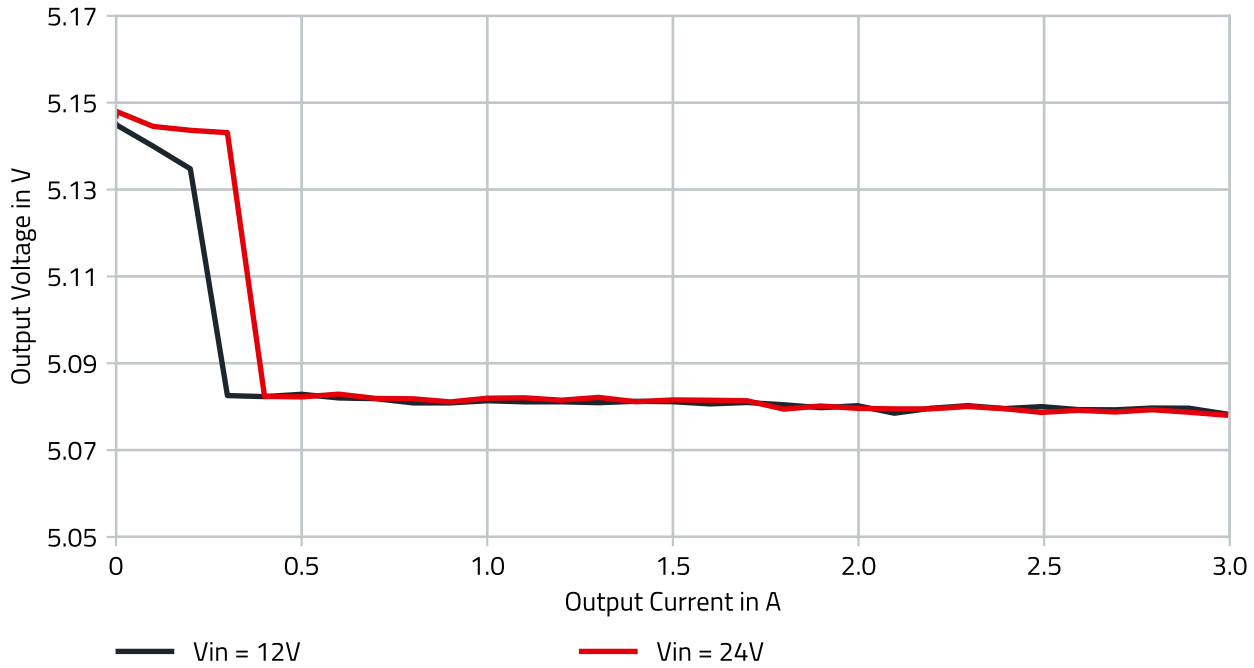

Figure 12: 171033801 Load Regulation $V_{OUT} = 5V$.

12.2.8 Line Regulation 1.8V_{OUT}

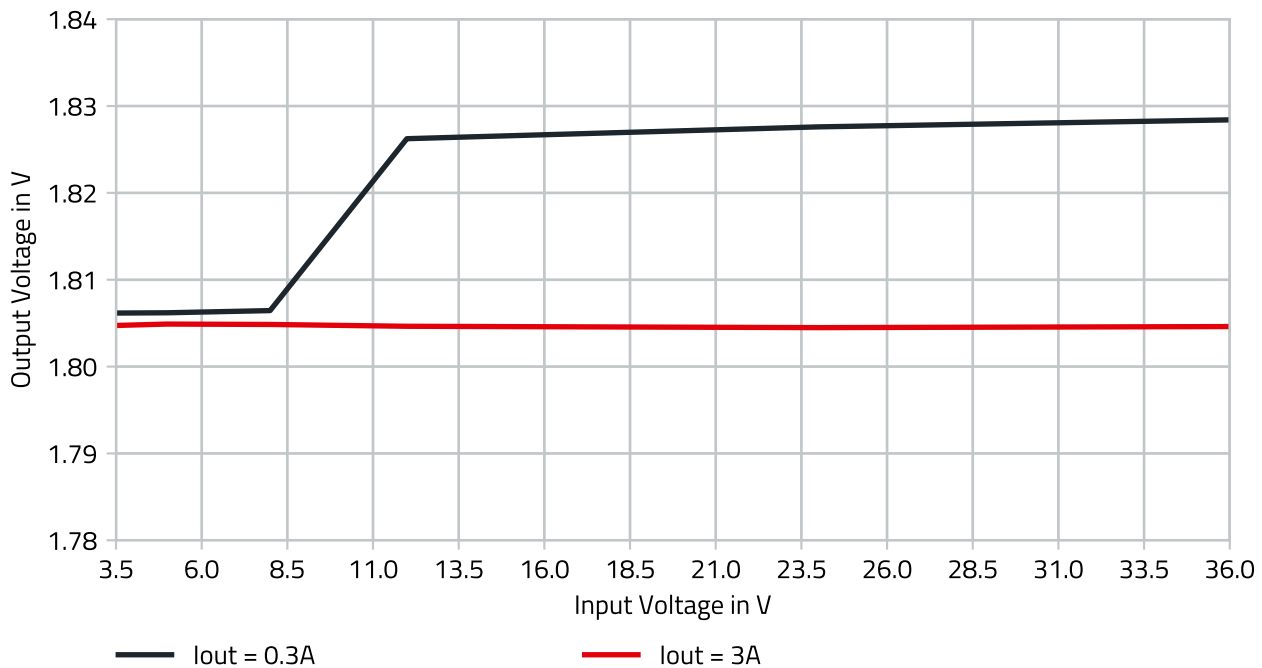

Figure 13: 171033801 Line Regulation $V_{OUT} = 1.8V$.

12.2.9 Line Regulation 3.3V_{OUT}

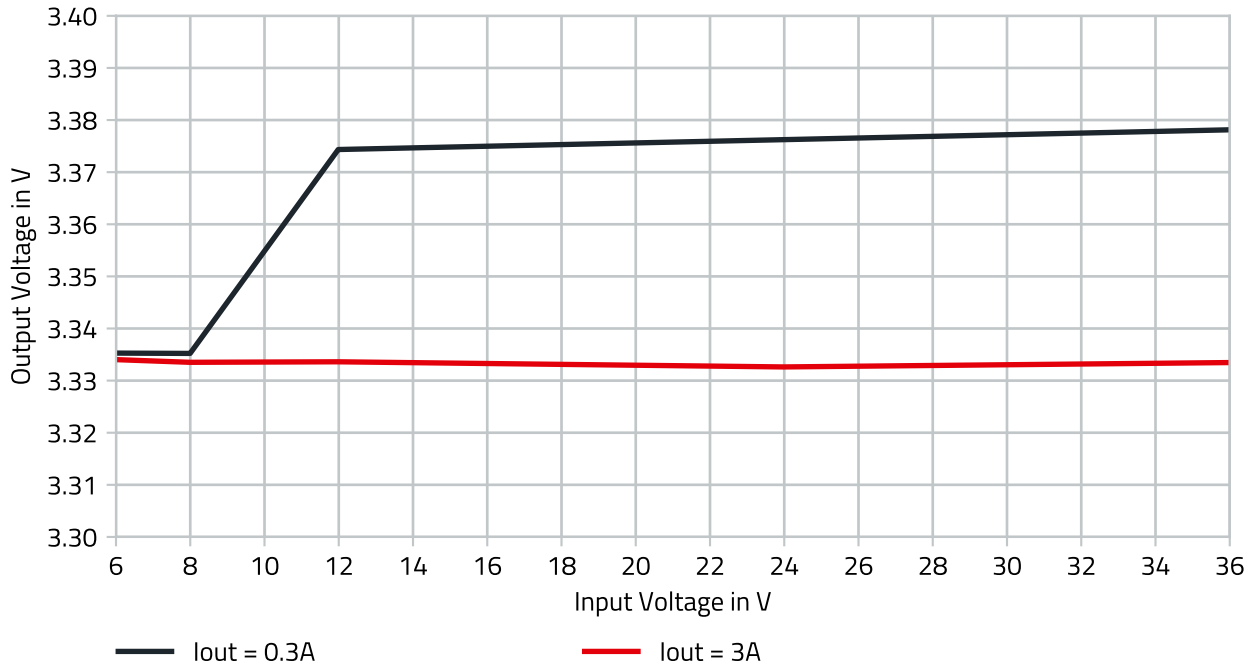

Figure 14: 171033801 Line Regulation $V_{OUT} = 3.3V$.

12.2.10 Line Regulation 5V_{OUT}

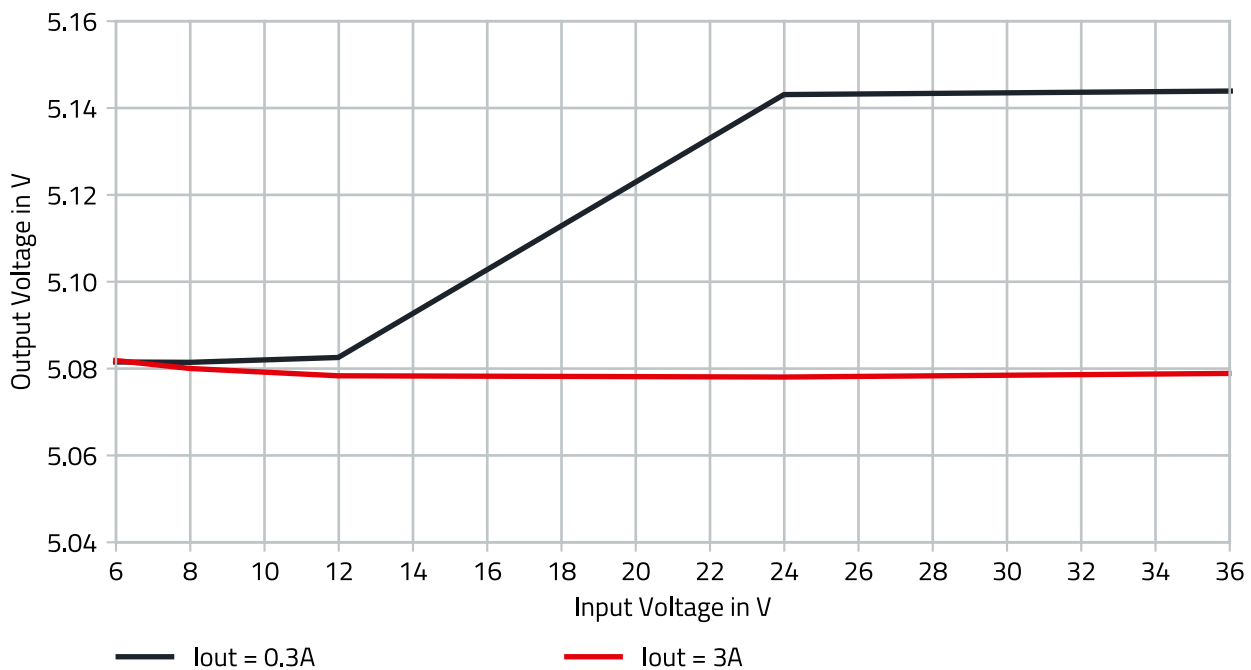

Figure 15: 171033801 Line Regulation $V_{OUT} = 5V$.

13 BLOCK DIAGRAM

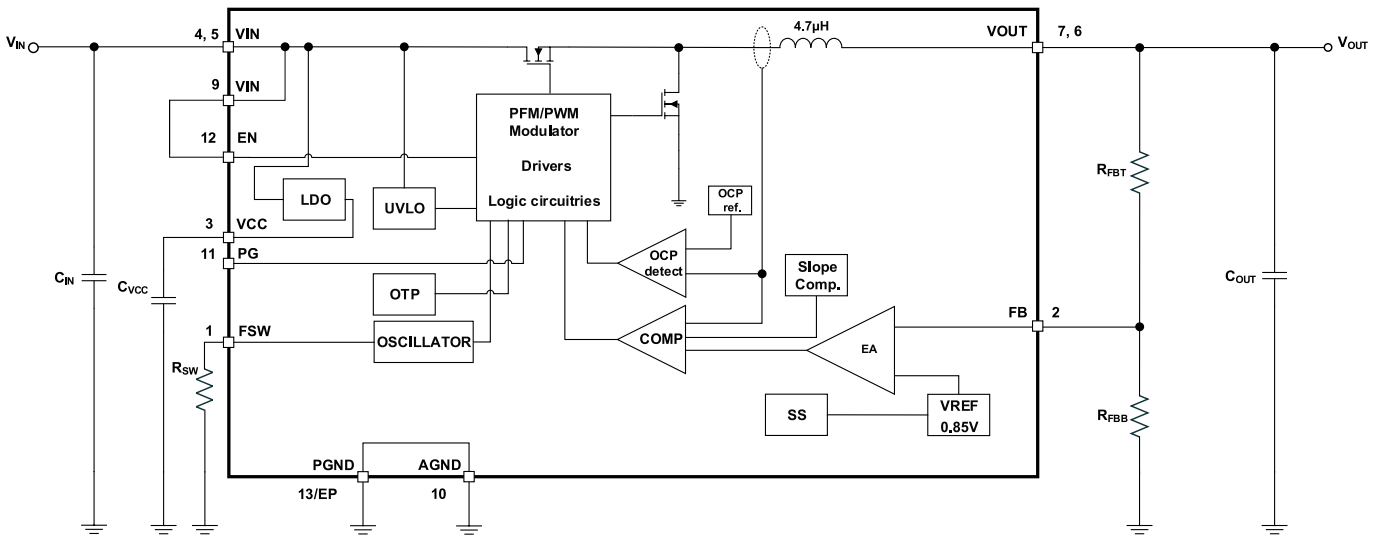

Figure 16: 171033801 block diagram.

14 CIRCUIT DESCRIPTION

The WPME-VDLM 171033801 power module is a DC-DC power supply including the switching regulator with integrated MOSFETs, controller and compensation, as well as the shielded inductor integrated in one package. The control scheme is based on a current mode (CM) regulation loop.

The V_{OUT} of the regulator is divided by the feedback resistor network R_{FBT} and R_{FBB} and fed into the FB pin. The error amplifier compares this signal with the internal 0.85V reference. The error signal is amplified and controls the on-time of a fixed frequency pulse width generator. This signal drives the power MOSFETs.

The current mode architecture features a constant frequency during load steps. Only the on-time is modulated. It is internally compensated and stable with low ESR output capacitors and requires no external compensation network.

This architecture supports fast transient response and very small output voltage ripples ($< 10mV_{p-p}$) are achieved.

15 DESIGN FLOW

The following simple steps will show how to select the external components to design the 171033801 into an application.

Essential Steps

1. Set output voltage
2. Select input capacitor
3. Select output capacitor
4. Select V_{CC} capacitor
5. Set switching frequency

Optional Steps

6. Set the power good resistor

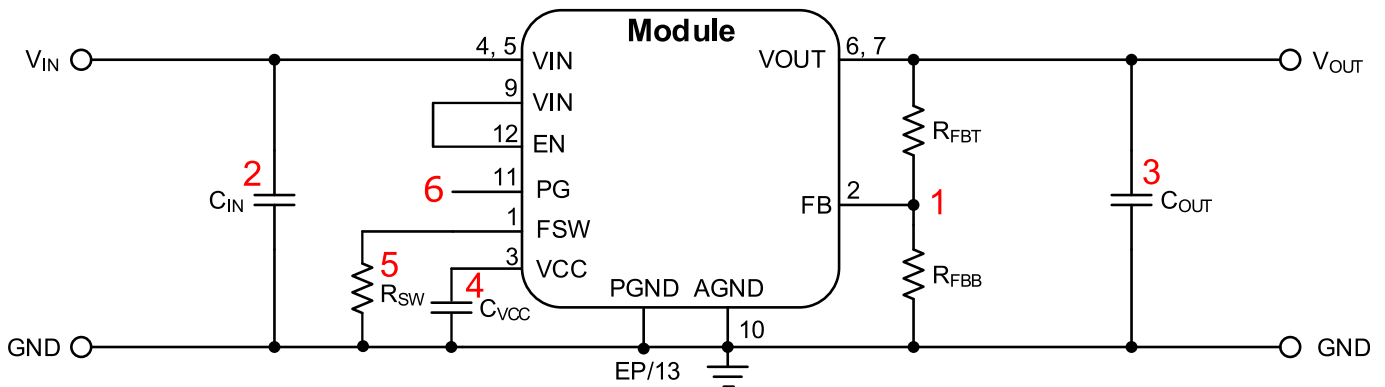

Figure 17: Design flow schematic.

15.1 STEP 1 Set the Output Voltage (V_{OUT})

The output voltage is selected with an external resistor divider between V_{OUT} and GND (see circuit below). The voltage across the lower resistor of the divider is provided to the FB pin and compared with a reference voltage of 0.85V (V_{REF}). The module can provide the entire output current of 3A with an output voltage range of 0.85V to 6V. If the output current is limited to 2.5A, the module can support a wider output voltage range of 0.85V to 13V. The output voltage can be calculated according to the following formula:

$$V_{OUT} = V_{REF} \cdot \left(\frac{R_{FBT}}{R_{FBB}} + 1 \right) \quad (1)$$

One resistor must be chosen and then the other resistor can be calculated. For example, if $R_{FBT} = 402\text{k}\Omega$ then the resistance value of the lower resistor in the feedback network is indicated in the table below for common output voltages.

Table 11: 171033801 output voltage selection.

V_{OUT} (V)	0.85	1.2	1.8	2.5	3.3	5.0	9.0*	12*
R_{FBB} (E96) ($\text{k}\Omega$)	Open	976	357	205	137	80.6	41.2	30.1

*Note that for output voltages above 6V, the output current may not exceed 2.5A.

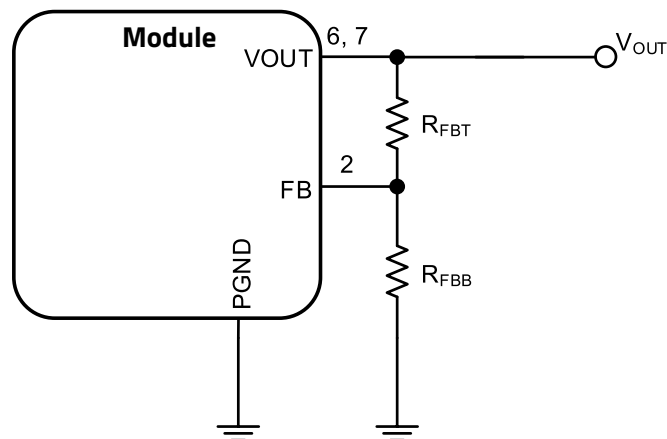

Figure 18: Output voltage selection schematic.

15.2 STEP 2 Select the Input Capacitor (C_{IN})

The energy at the input of the power module is stored in the input capacitor. An MLCC (multi-layer ceramic capacitor) input capacitor (10 μF) is required externally to provide cycle-by-cycle switching current and to support load transients. The external input capacitor must be placed directly at the VIN pin. Attention must be paid to the voltage, frequency, temperature derating and thermal class of the selected capacitor. Two of the Würth Elektronik 885012209048 MLCCs in parallel have been experimentally verified to work with this power module.

15.3 STEP 3 Select the Output Capacitor (C_{OUT})

The output capacitor should be selected in order to minimize the output voltage ripple and to provide a stable voltage at the output. It also affects the loop stability. Different output capacitors are recommended depending on the output voltage and

switching frequency selected for an application. Attention must be paid to the voltage, frequency and temperature derating and thermal class of the selected capacitor.

In general, the output voltage ripple can be calculated using the following equation:

$$V_{\text{OUT,ripple}} = \Delta I_L \cdot ESR + \Delta I_L \cdot \left(\frac{1}{8 \cdot f_{\text{SW}} \cdot C_{\text{OUT}}} \right) \quad (2)$$

where ΔI_L is the inductor current ripple and can be calculated with the following equation:

$$\Delta I_L = \frac{V_{\text{OUT}} \cdot (V_{\text{IN}} - V_{\text{OUT}})}{f_{\text{SW}} \cdot L \cdot V_{\text{IN}}} \quad (3)$$

The following table shows common output voltage values and their corresponding recommended output capacitance. These capacitance values have all been experimentally verified for their corresponding output voltages. Use of different output capacitors for a given output voltage requires the designer to verify the selected capacitor(s) for functionality. These capacitors can all be found within the Würth Elektronik capacitor portfolio, specifically the WCAP-CSGP and WCAP-PSLP families.

Table 12: 171033801 output capacitor selection.

V _{OUT} (V)	0.85	1.2	1.8	2.5	3.3	5.0
C _{OUT} (µF)	440 (6.3V)	200 (6.3V)	200 (6.3V)	100 (6.3V)	47 (6.3V)	47 (10V)

Using the recommended output capacitors, the transient response of the power module can appear as follows:

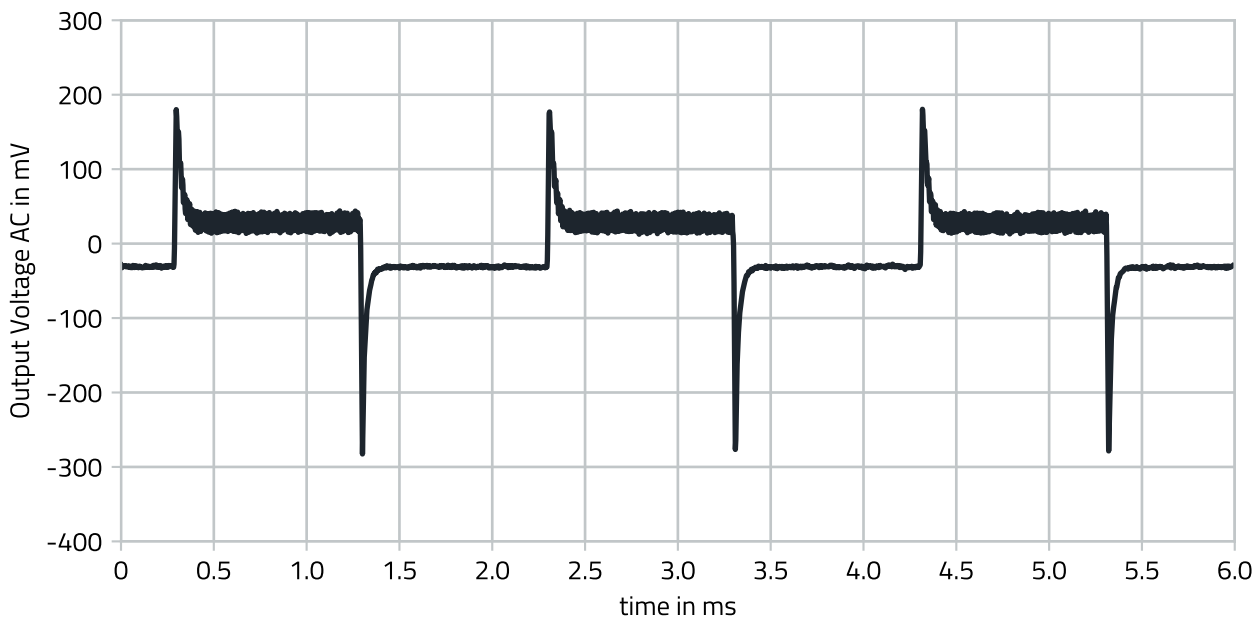

Figure 19: 171033801 V_{IN} = 24V, V_{OUT} = 5V, C_{OUT} = 47µF, load jumps 10% - 100%.

15.4 STEP 4 Select the V_{CC} Capacitor (C_{VCC})

The 171033801 MagI³C Module requires a capacitor (C_{VCC}) to be placed at the VCC pin to support the internal LDO integrated inside of the module. To ensure stable operation and optimum performance across the entire functional range, a 1µF capacitor is recommended. The Würth Elektronik 885012207051 capacitor has been experimentally evaluated for performance and is the recommended choice.

15.5 STEP 5 Select the Switching Frequency (f_{sw})

The switching frequency must be selected according to the input voltage, output voltage and load current for the best performance in loop regulation and transient response. This is done by choosing a resistor value from the table below based on the application conditions. This resistor can either be tied directly to AGND for a fixed switching frequency, indicated in the table below, or it can be tied to VCC allow for spread spectrum operation. Spread spectrum operation will allow for a change in switching frequency typically of $\pm 5\%$. The peaks of the switching spectrum will be reduced and spread, reducing the filter necessary to comply to EN55032 Radiated and Conducted Standards. The difference in EMI behavior can be seen in the EMI section of the data sheet.

Table 13: 171033801 switching frequency selection.

V_{OUT} (V)	0.85	1.2	1.8	2.5	3.3	5	9*	12*
Switching Frequency (kHz)	200	400	400	500	700	700	1500	1500
R_{SW} (k Ω)	1.8	0	0	3.3	5.6	5.6	18	18

*Note that for output voltages above 6V, the output current may not exceed 2.5A.
When R_{SW} is indicated as 0 k Ω , FSW should be tied directly to AGND or VCC.

These values have been experimentally validated for optimum performance with the given output voltages. Deviation from the recommendations is taken at the user's own risk and should be experimentally evaluated in the designated application to ensure proper functionality.

15.6 STEP 6 Optional: Set the Power Good Resistor

The PG pin is an open-drain output. Once the output voltage is above 90% (typ.) of the internal reference voltage, the PG pin transitions to a high impedance state. The recommended pull-up resistor value is 1M Ω , which should be connected to a voltage source such as VIN. The PG pin is pulled low when the output voltage is lower than 90% (typ.) or higher than 120% (typ.) of the internal reference voltage. The PG pin will be pulled low when the UVLO or thermal shutdown activates or when the EN pin is pulled low.

16 MODES OF OPERATION

The 171033801 power module has two different modes of operation and the transition takes place automatically depending on the load current value. Under light load conditions, the module operates in PFM mode where the Module runs at a lower switching frequency to reduce the current consumption, which leads to achieving a higher efficiency. The PFM control is achieved by creating a single pulse to turn on the high side switch while monitoring the inductor current. The high side switch is kept on until the inductor current hits a preset value of 600mA (typ.).

After reaching this value, the high side switch is turned off and the low side switch turns on. The inductor current decreases until it reaches zero. When the inductor current reaches zero, both switches are turned off (idle time) and the output capacitor solely supplies the load with energy. While the energy is supplied to the load, the output voltage starts to drop. The Module monitors the output voltage ripple value and when it hits a certain limit, while the two switches are off, another pulse is initiated and the cycle repeats. When the load current increases, the idle time decreases and the switching frequency increases until the nominal switching frequency is reached and the Module transitions to PWM mode.

17 OUTPUT VOLTAGE RIPPLE

If the power module is working in PWM mode, the output voltage ripple is very low and is determined by the switching frequency, which is set by the resistor R_{SW} . If the load current is low enough to be in the PFM mode of operation then the output voltage ripple will be higher with a frequency lower than the nominal switching frequency (see pictures below).

17.1 PFM Operation

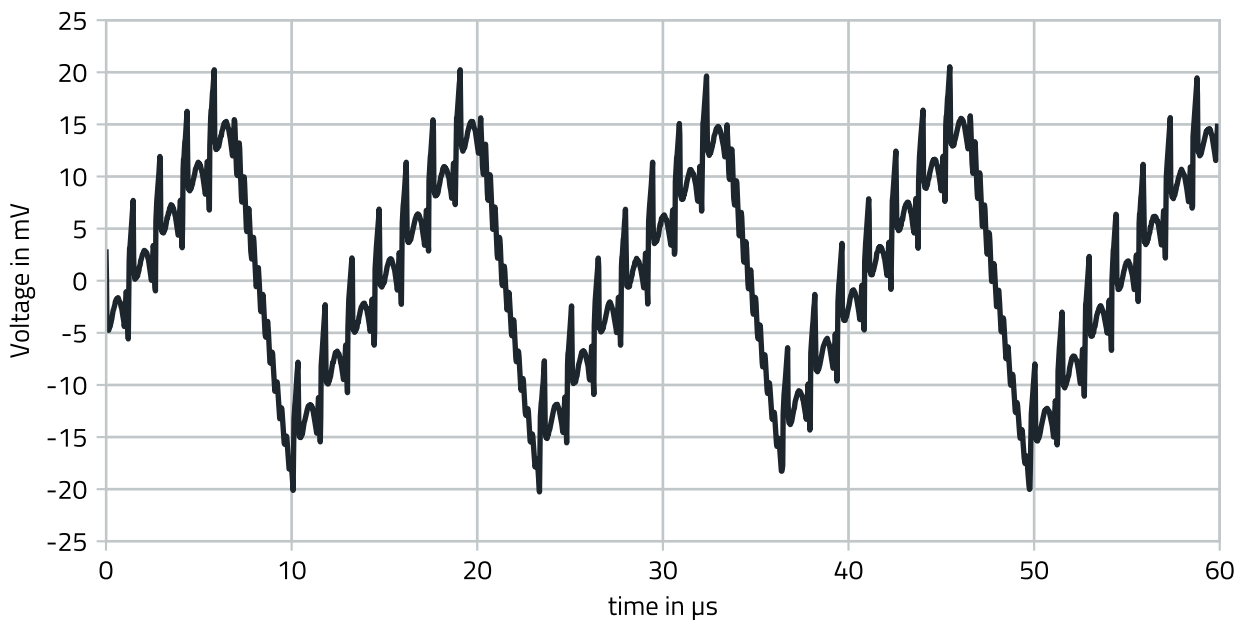

Figure 20: 171033801 output voltage ripple $V_{IN} = 24V$, $V_{OUT} = 5V$, $I_{OUT} = 300mA$, $C_{OUT} = 47\mu F$.

17.2 PWM Operation

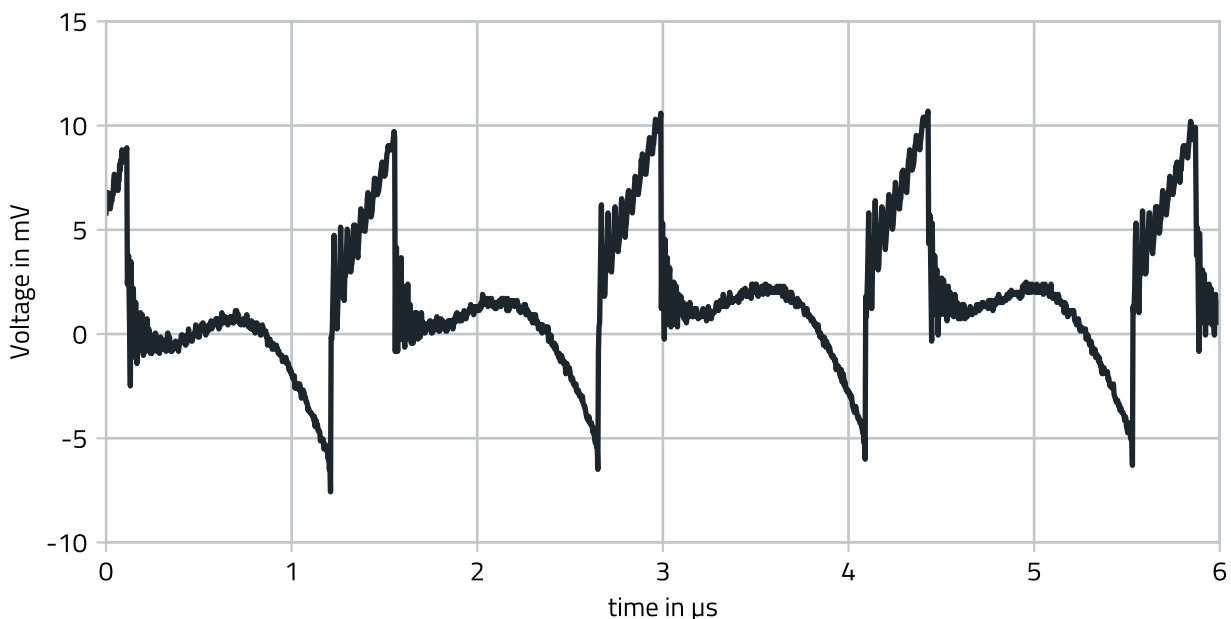

Figure 21: 171033801 output voltage ripple $V_{IN} = 24V$, $V_{OUT} = 5V$, $I_{OUT} = 3A$, $C_{OUT} = 47\mu F$.

18 PROTECTION FEATURES

18.1 Overcurrent Protection (OCP) and Short Circuit Protection (SCP)

The MagI³C 171033801 power module implements a cycle-by-cycle current limit (see I_{OCP} in [ELECTRICAL SPECIFICATION](#)), which is realized through the peak current mode control architecture of the power module. The peak current of the high side switch and the valley current of the low side switch are both monitored. Additionally, limiting the valley current during an overcurrent scenario reduces the thermal stresses generated inside of the power module by reducing the rms current value.

By monitoring both switch currents the user can be confident that the power module will be well protected against overcurrent and short circuit scenarios even in the most extreme conditions of operation, such as very high or low duty cycles. Under very low duty cycle conditions, the peak current can exceed the overcurrent preset value. When this occurs, the low side switch is turned on until the current drops below the preset valley current value. This behavior may result in pulse skipping, temporarily decreasing the effective switching frequency in order to better protect the power module during overcurrent scenarios.

The inductor current exceeding the peak protection value will only take place if the minimum on-time stated in the [ELECTRICAL SPECIFICATIONS](#) is violated. Even in such a scenario, the power module will still be protected. Following the recommended switching frequencies stated in [Step 5](#) of the [DESIGN FLOW](#) will always ensure the minimum on-time is maintained.

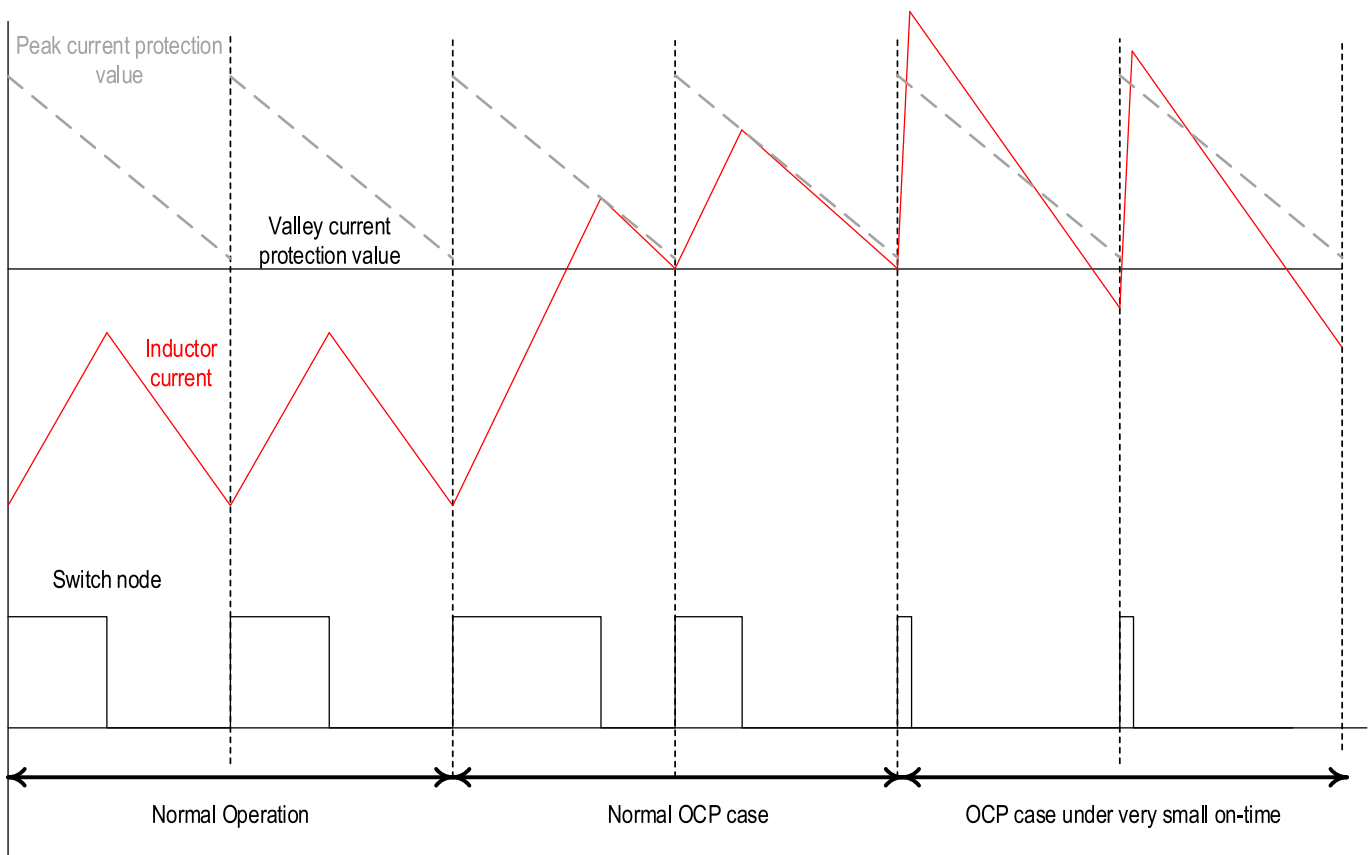

Figure 22: 171033801 overcurrent protection inductor current.

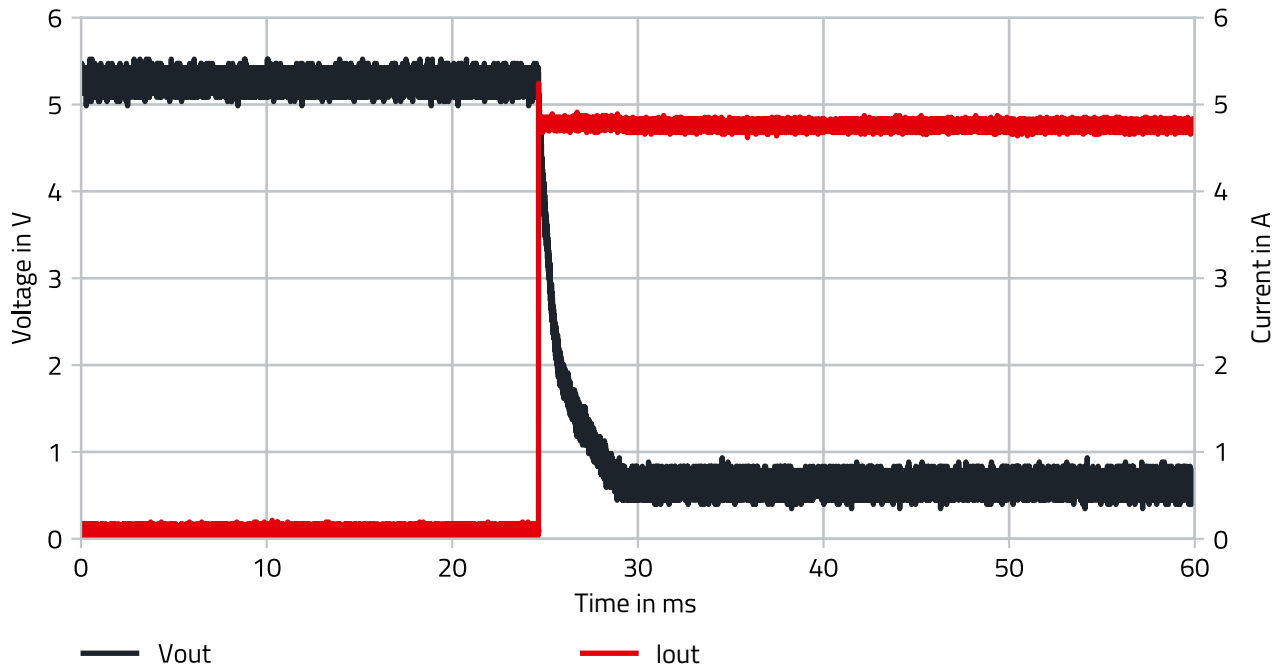

Figure 23: 171033801 overcurrent protection $V_{IN} = 24V$, $V_{OUT} = 5V$, $I_{OUT} = 0A$ to $4.8A$.

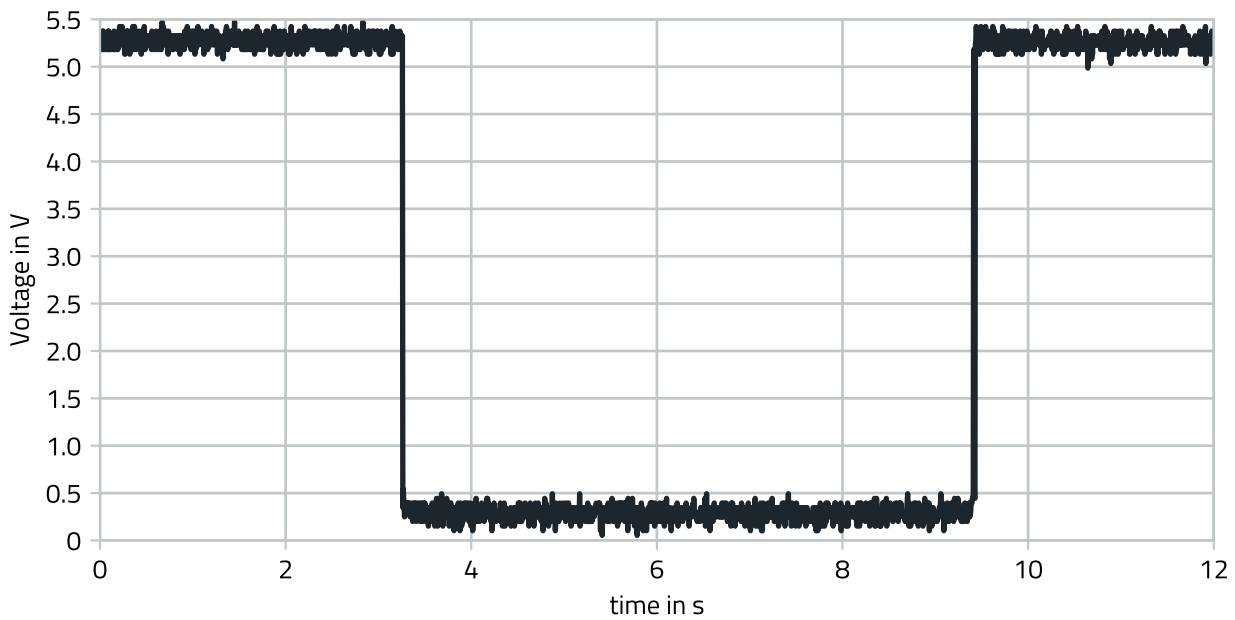

Figure 24: 171033801 short circuit protection $V_{IN} = 24V$, $V_{OUT} = 5V$.

18.2 Output Overvoltage Protection (OVP)

The MagI³C power module integrates an output overvoltage protection feature. This feature is implemented by monitoring the feedback pin and comparing it to the internal reference. When the feedback pin voltage is 20% higher than the reference voltage, the low side switch is turned on to discharge the output capacitor. There is also a negative current limit set on the low side switch to prevent overcurrent stress when this protection feature activates.

18.3 Over Temperature Protection (OTP)

Thermal protection helps prevent catastrophic failures due to accidental device overheating. The junction temperature of the MagI³C power module should not be allowed to exceed its maximum ratings. Thermal protection is implemented by an internal thermal shutdown circuit, which activates when the junction temperature reaches 165 °C (typ). Under the thermal shutdown condition both MOSFETs remain off, causing the output voltage to drop. When the junction temperature falls below 135 °C (typ) the internal soft-start is released, V_{OUT} rises smoothly, and normal operation resumes.

18.4 Soft-Start

The MagI³C power module implements an internal soft-start in order to limit the inrush current and avoid output voltage overshoot during start-up. The typical duration of the soft-start is around 1.3ms (see figure below).

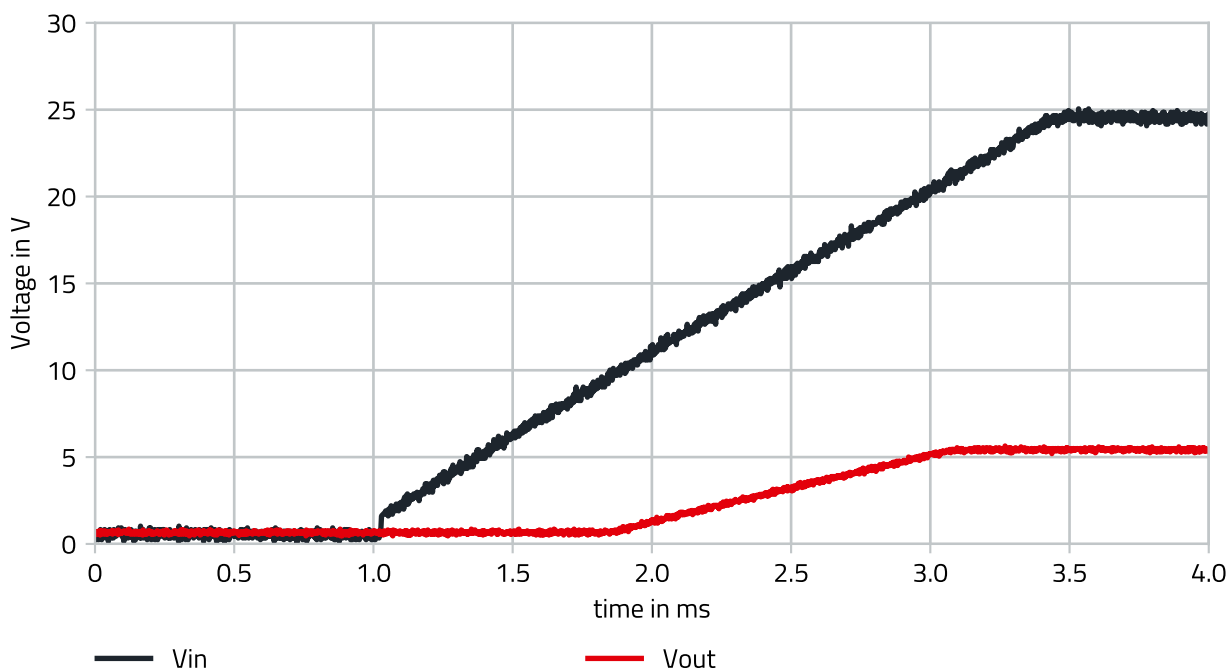

Figure 25: 171033801 soft-start $V_{IN} = 24V$, $V_{OUT} = 5V$, $T_A = 25^\circ C$.

18.5 Enable and Integrated/Adjustable UVLO

The MagI³C power module is enabled by setting the EN pin high. When the EN voltage reaches 1.2V the power module begins switching and the internal soft-start regulates the output voltage rise until the desired output voltage is met, allowing normal operation to take place.

The device incorporates an internal input undervoltage lockout (UVLO) to protect from unexpected behavior at input voltages below the recommended values. The thresholds of the internal UVLO are indicated in the [ELECTRICAL SPECIFICATIONS](#).

An additional UVLO threshold of the power module can be externally set by adding a resistor between VIN and EN and a second resistor between EN and GND. This voltage divider should be chosen so that the desired minimum input voltage

corresponds to 1.2V at EN.

The two resistors should be chosen based on the following ratio:

$$\frac{R_{ENT}}{R_{ENB}} = \frac{V_{UVLO(EXT.)}}{1.2} - 1 \quad (4)$$

$V_{UVLO(EXT.)}$ = User-programmable input voltage threshold to enable and disable the power module

This is often used in battery-powered systems to prevent deep discharge of the system battery. It is also useful in system designs with output rail sequencing or to prevent early turn-on of the supply as the main input voltage rail rises at power-up. Most systems will benefit by using the precision Enable threshold to establish a system undervoltage lockout based on specific application parameters.

In the case of sequencing supplies, the divider is connected to a rail that becomes active earlier in the power-up cycle than the MagI³C power module output rail. The recommended approach is to choose an input UVLO level that is higher than the target regulated output voltage for the stage.

19 DESIGN EXAMPLE

The design example shows a possible solution for 24V to 5V with a maximum output current of 3A. All of the necessary components to fulfill the requirements of the CISPR 32 EMI conducted- and radiated emissions tests are included in the design example. It passes the conducted emissions class B with 0.8m input and 1m output lines. Filter components may be omitted depending on the requirements of the final application.

19.1 Layout

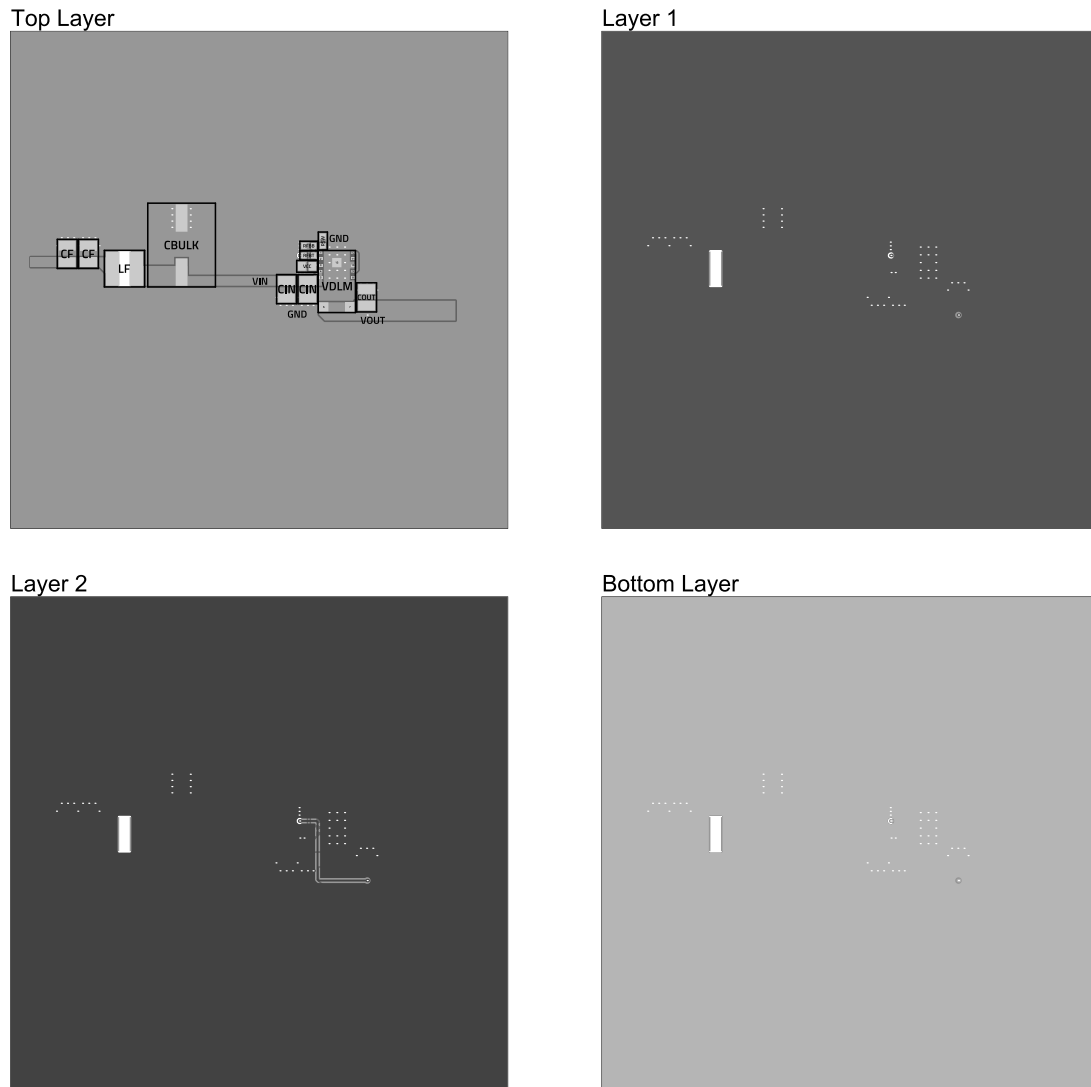

Figure 26: 171033801 layout recommendation.

The images above show the top, inner and bottom routed layers for a recommended four layer layout. There are two internal GND layers that are necessary for optimal thermal performance. The pictures above show a possible layout for the 171033801 MagI³C power module. Nevertheless, some recommendations should be followed when designing the layout:

1. The input and output capacitors should be placed as close as possible to the VIN and VOUT pins of the device.
2. The feedback resistor divider should be placed as close as possible to the FB pin.
3. Avoid placing vias in any of the pads for the module.

19.2 Schematic

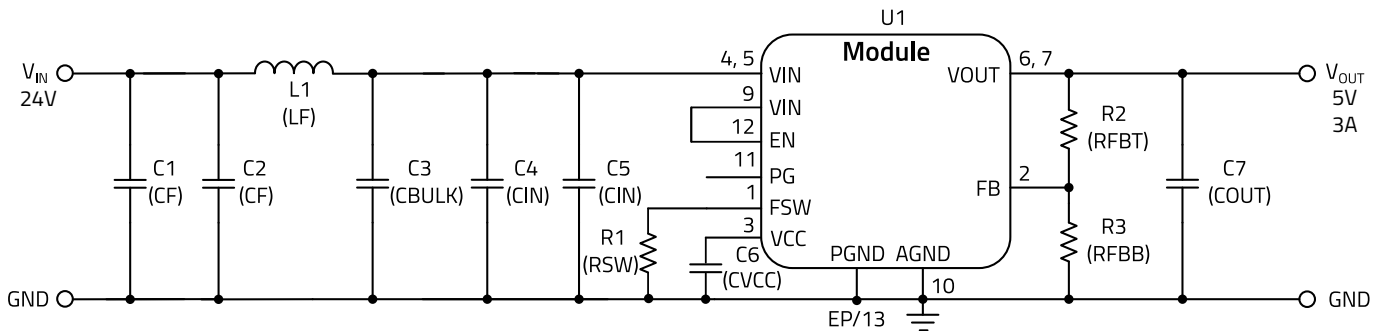

Figure 27: 171033801 design example schematic.

19.3 Bill of Materials

Table 14: 171033801 design example bill of materials.

Designator	Description	Function	Quantity	Order Code	Manufacturer
U1	Magl ³ C power module	Power supply	1	171033801	WE
L1	Filter inductor, 10 μ H, PD2 family, $I_{SAT} = 2.5A$, $I_R = 2.2A$	Input filter	1	74477410	WE
C1, C2, C4, C5	Ceramic chip capacitor 4.7 μ F, 50V, X7R, 1210	Input filter	1	885012209048	WE
C3	Aluminum electrolytic capacitor 220 μ F, 50V	Input filter	1	865060657012	WE
C6	Ceramic chip capacitor 1 μ F, 16V, X7R, 0805	Electrical performance	1	885012207051	WE
C7	Ceramic chip capacitor 47 μ F, 16V, X5R, 1210	Electrical performance	1	885012109011	WE
R1	5.6k Ω	Electrical performance	1	—	—
R2	402k Ω	Electrical performance	1	—	—
R3	80.6k Ω	Electrical performance	1	—	—

20 HANDLING RECOMMENDATIONS

1. The power module is classified as MSL3 (JEDEC Moisture Sensitivity Level 3) and requires special handling due to moisture sensitivity (JEDEC J-STD033D).
2. The parts are delivered in a sealed bag (Moisture Barrier Bag = MBB) and should be processed within one year.
3. When opening the moisture barrier bag, check the Humidity Indicator Card (HIC) for color status. Bake parts prior to soldering in case indicator color has changed according to the notes on the card.
4. Parts must be processed after 168 hour (7 days) of floor life. Once this time has been exceeded, bake parts prior to soldering per JEDEC J-STD033D recommendation.
5. Maximum number of solder cycles is two.
6. For minimum risk, solder the module in the last solder cycle of the PCB production.
7. For soldering process please consider lead material copper (Cu) and lead finish tin (Sn).
8. It is recommended to use a standard SAC Alloy such as SAC 305, type 3 or higher.
9. The profile below is valid for convection reflow only.
10. Other soldering methods (e.g. vapor phase) are not verified and have to be validated by the customer at their own risk.

21 SOLDER PROFILE

Table 15: Reflow solder profile.

Profile Feature	Symbol	Value
Preheat temperature minimum	T_{s_min}	150°C
Preheat temperature maximum	T_{s_max}	200°C
Preheat time from T_{s_min} to T_{s_max}	t_s	60-120 seconds
Liquidous temperature	T_L	217°C
Time maintained above T_L	t_L	60-150 seconds
Classification temperature	T_C	250°C
Peak package body temperature	T_P	$T_P \leq T_C$
Time within 5°C of actual peak temperature	t_p	$t_p \leq 30$ seconds
Ramp-up Rate (T_L to T_P)		3°C/second maximum
Ramp-down rate (T_P to T_L)		6°C/second maximum
Time 25°C to peak temperature		8 minutes maximum

Please refer to JEDEC J-STD020E for further information pertaining to reflow soldering of electronic components.

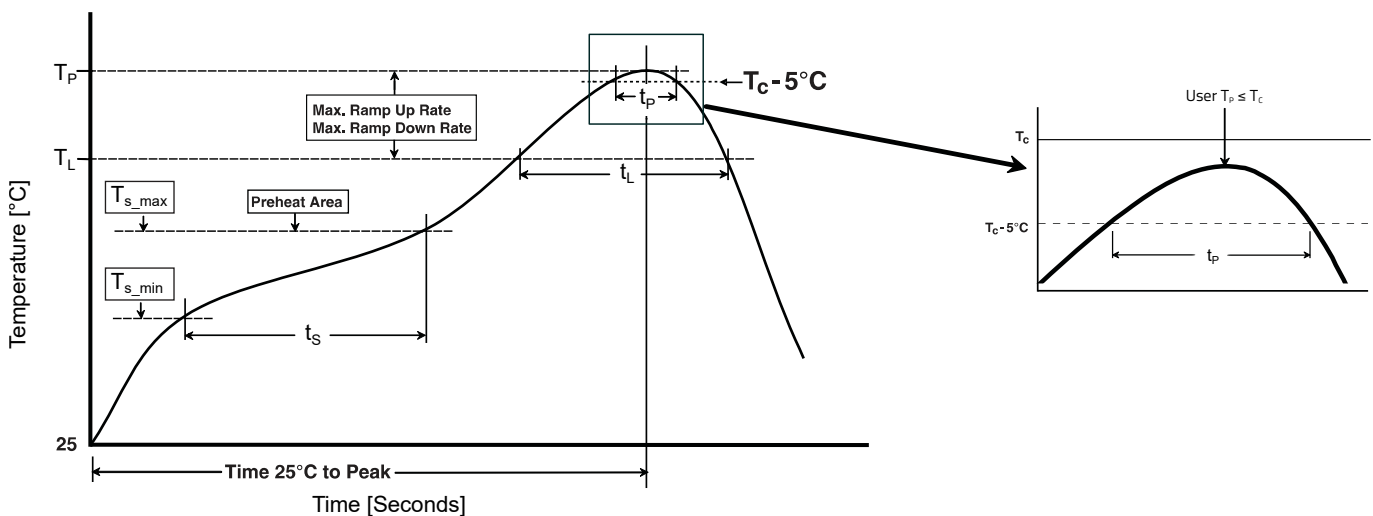
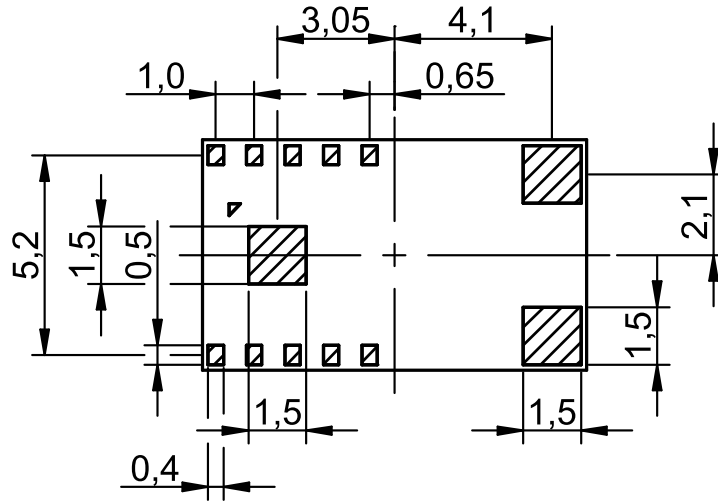

Figure 28: Solder profile.

22 PHYSICAL DIMENSIONS

22.1 Component



Bottom view

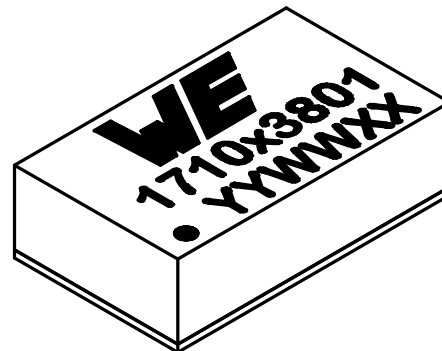
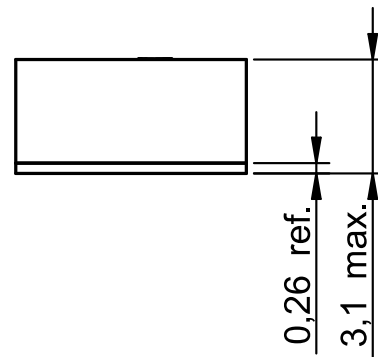
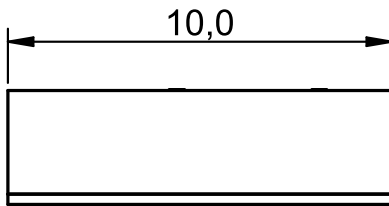

Figure 29: Physical dimensions.

All dimensions in mm
 Tolerances $\pm 0,1$ mm unless otherwise specified

22.2 Example Landpattern Design

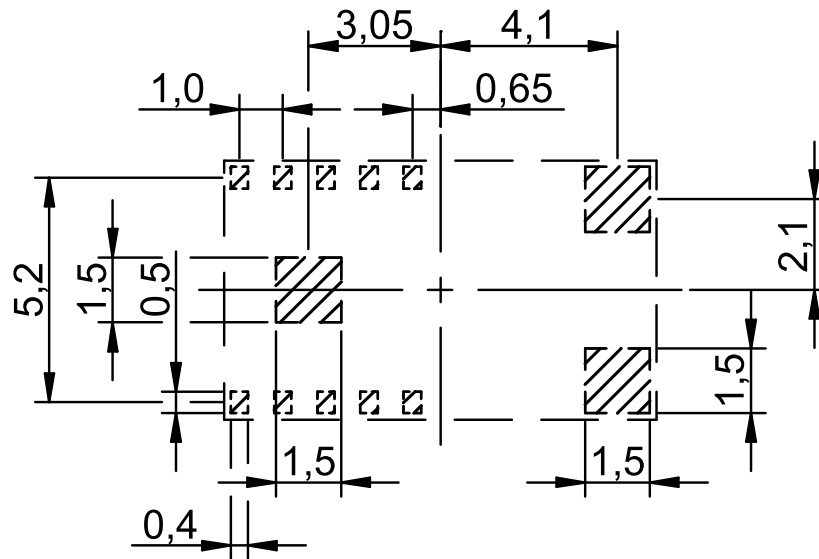

Figure 30: Example landpattern design.

All dimensions in mm
Stencil thickness of 100µm

22.3 Tape

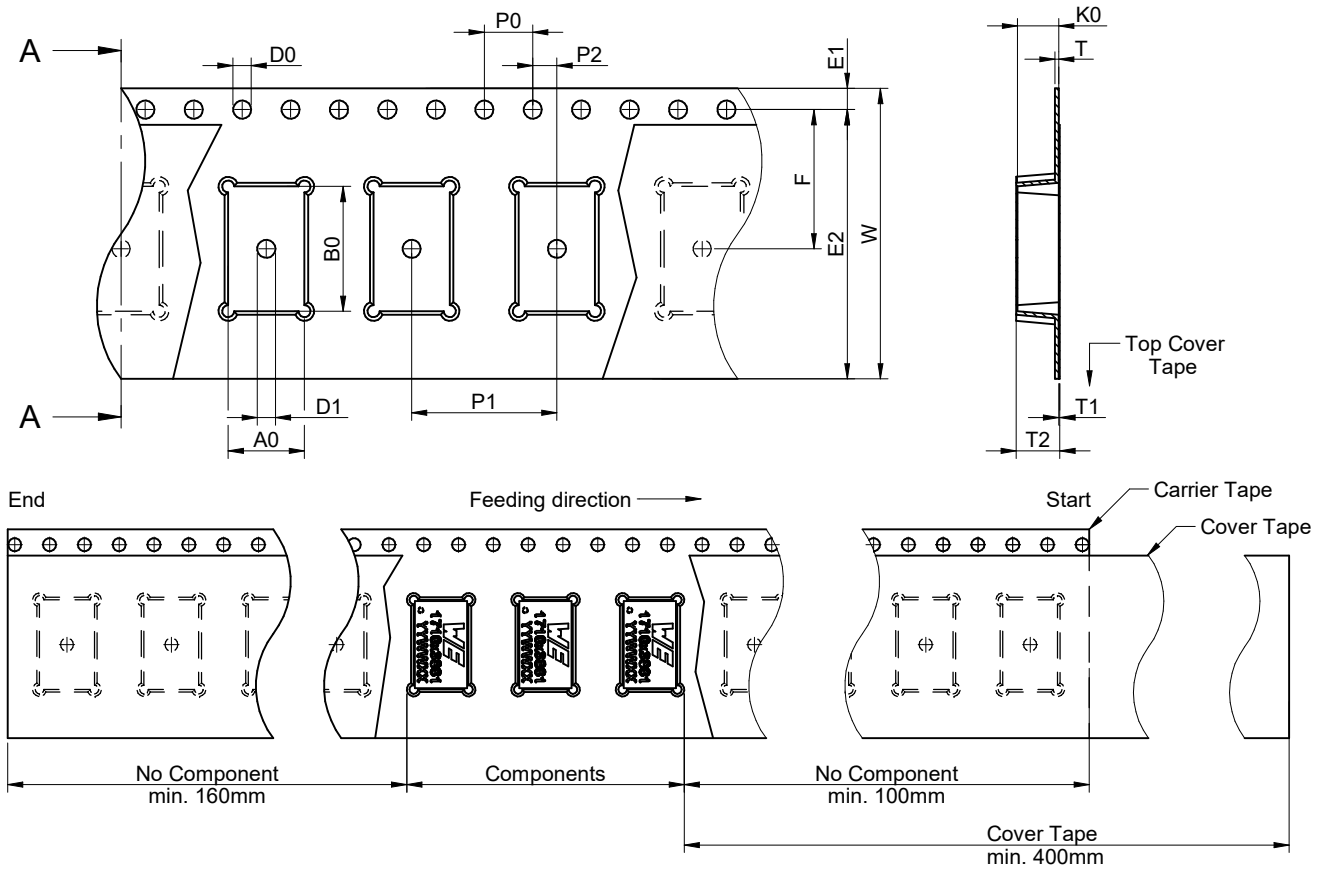

Figure 31: Tape.

Table 16: Tape dimensions.

Tape Type	A0	B0	W	T	K0	P0	P1	P2	D0	D1	E1	E2	F	Material
	±0.1	±0.1	±0.3	±0.05	±0.1	±0.1	±0.1	±0.1	+0.1	Min.	±0.1	±0.4	±0.1	
2a	6.3	10.3	24	0.3	3.4	4	12	2	1.5	.51	1.75	22.25	11.50	Polystyrene

All dimensions in mm

22.4 Reel

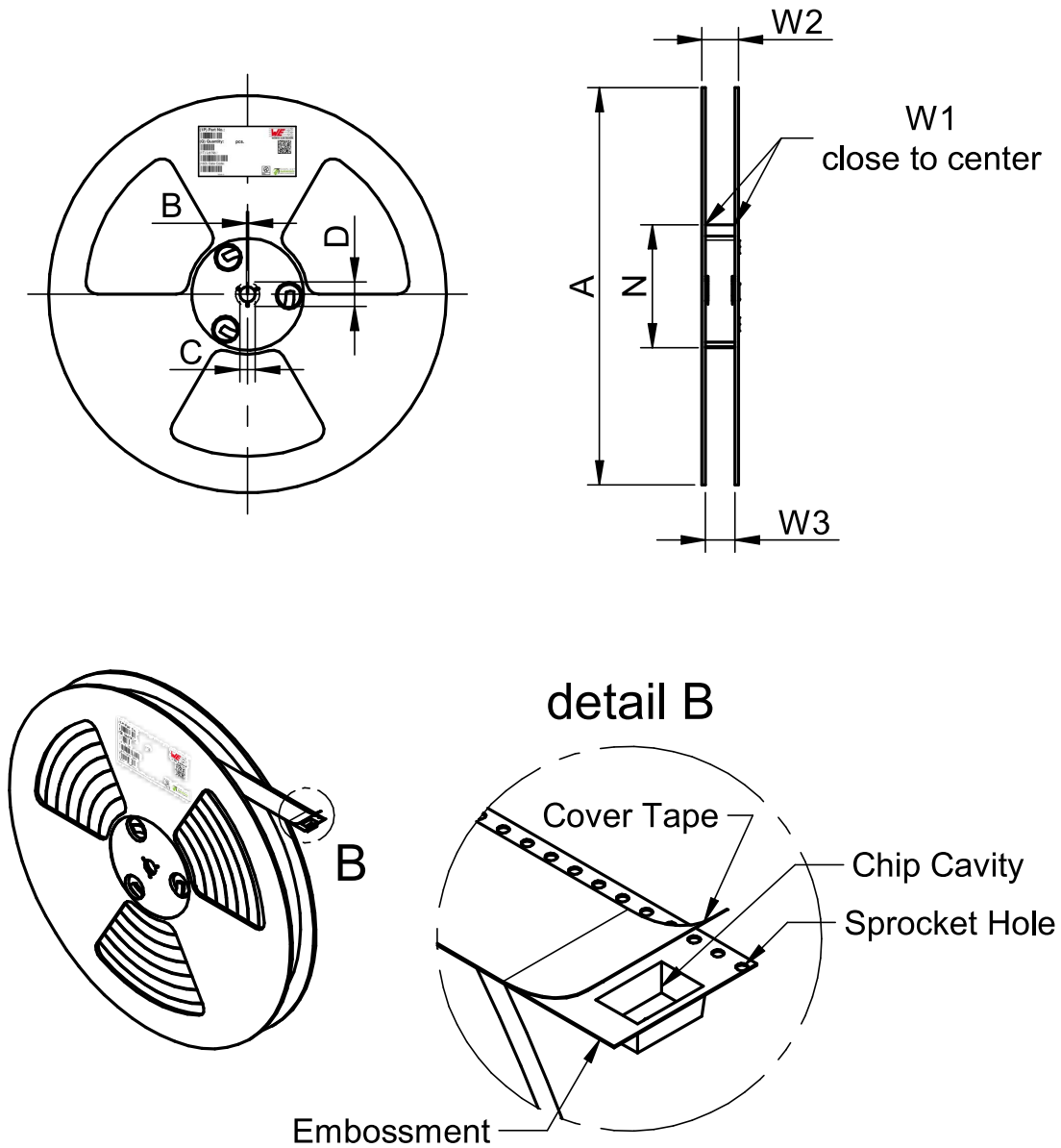

Figure 32: Reel.

Table 17: Reel dimensions.

A	B	C	D	N	W1	W2	W3	Material
±1.0	±0.5	±0.5	Min.	±0.5	Typ.	Typ.	Typ.	
330.00	2.0	13.00	12.50	102.00	30.2	30.2	24.8	Polystyrene

All dimensions in mm

All dimensions in mm.

23 DOCUMENT HISTORY

Table 18: Document history.

Revision	Date	Description	Comment
1.0	February 2022	Initial data sheet release	
1.1	March 2022	Correction of component values	1. Feedback resistor value for 5Vo corrected 2. Cff removed from EMI conditions
1.2	October 2022	Updated design example layout pictures	
2.0	February 2024	PCN	<p>For the purpose of a datasheet information enlargement, Würth Elektronik has added the minimum off-time in the electrical specification table. As a datasheet amendment, Würth Elektronik will no longer offer an output overvoltage protection feature. Due to internal standardization, Würth Elektronik aligned the datasheet to the internal standard.</p>
3.0	November 2024	PCN	<p>To increase the production capability, Würth Elektronik eiSos has shifted the production of the affected article numbers to a new factory location.</p> <p>With the aim of an extended product applicability, Würth Elektronik eiSos has updated the switching regulator IC used in the module to ensure the best performance and the electrical specifications and protection features sections have been expanded to included output overvoltage protection. The datasheet with the changes is attached to this PCN. This is only a revision of the existing IC and not a change to a new IC.</p>

24 LIST OF FIGURES

1	Pinout.	4
2	Radiated emissions (fixed frequency).	10
3	Radiated emissions (spread spectrum).	10
4	Conducted emissions (fixed frequency).	11
5	Conducted emissions (spread spectrum).	11
6	Efficiency $V_{IN} = 12V$	12
7	Efficiency $V_{IN} = 24V$	12
8	Output current thermal derating $V_{IN} = 12V, V_{OUT} = 5V$	13
9	Output current thermal derating $V_{IN} = 24V$	13
10	Load regulation $V_{OUT} = 1.8V$	14
11	Load regulation $V_{OUT} = 3.3V$	14
12	Load regulation $V_{OUT} = 5V$	15
13	Line regulation $V_{OUT} = 1.8V$	15
14	Line regulation $V_{OUT} = 3.3V$	16
15	Line regulation $V_{OUT} = 5V$	16
16	Block diagram.	17
17	Design flow schematic.	18
18	Output voltage selection schematic.	19
19	Transient response $V_{IN} = 24V, V_{OUT} = 5V, C_{OUT} = 47\mu F$, load jumps 10% - 100%.	20
20	Output voltage ripple $V_{IN} = 24V, V_{OUT} = 5V, I_{OUT} = 300mA, C_{OUT} = 47\mu F$	22
21	Output voltage ripple $V_{IN} = 24V, V_{OUT} = 5V, I_{OUT} = 3A, C_{OUT} = 47\mu F$	22
22	Overcurrent protection inductor current.	23
23	Overcurrent protection $V_{IN} = 24V, V_{OUT} = 5V, I_{OUT} = 0A$ to 4.8A.	24
24	Short circuit protection $V_{IN} = 24V, V_{OUT} = 5V$	24
25	Soft start $V_{IN} = 24V, V_{OUT} = 5V, T_A = 25^\circ C$	25
26	Layout recommendation.	27
27	Design example schematic.	28
28	Solder profile.	29
29	Physical dimensions.	30
30	Example landpattern design.	31
31	Tape.	32
32	Reel.	33



25 LIST OF TABLES

1	Pin description.	4
2	Ordering information.	5
3	Pinout compatible family members.	5
4	Sales information.	5
5	Absolute maximum ratings.	6
6	Operating conditions.	6
7	Thermal specifications.	6
8	Electrical specifications.	7
9	RoHS, REACH.	8
10	Package specifications	8
11	Output voltage selection.	19
12	Output capacitor selection.	20
13	Switching frequency selection.	21
14	Design example bill of materials.	28
15	Reflow solder profile.	29
16	Tape dimensions.	32
17	Reel dimensions.	33
18	Document history.	34

26 CAUTIONS AND WARNINGS

The following conditions apply to all goods within the product series of MagI³C of Würth Elektronik eiSos GmbH & Co. KG:

General:

- All recommendations according to the general technical specifications of the data-sheet have to be complied with.
- The usage and operation of the product within ambient conditions which probably alloy or harm the component surface has to be avoided.
- The responsibility for the applicability of customer specific products and use in a particular customer design is always within the authority of the customer. All technical specifications for standard products do also apply for customer specific products
- Residual washing varnish agent that is used during the production to clean the application might change the characteristics of the body, pins or termination. The washing varnish agent could have a negative effect on the long term function of the product. Direct mechanical impact to the product shall be prevented as the material of the body, pins or termination could flake or in the worst case it could break. As these devices are sensitive to electrostatic discharge customer shall follow proper IC Handling Procedures.
- Customer acknowledges and agrees that it is solely responsible for compliance with all legal, regulatory and safety-related requirements concerning its products, and any use of Würth Elektronik eiSos GmbH & Co. KG components in its applications, notwithstanding any applications-related information or support that may be provided by Würth Elektronik eiSos GmbH & Co. KG.
- Customer represents and agrees that it has all the necessary expertise to create and implement safeguards which anticipate dangerous consequences of failures, monitor failures and their consequences lessen the likelihood of failures that might cause harm and take appropriate remedial actions
- Customer will fully indemnify Würth Elektronik eiSos and its representatives against any damages arising out of the use of any Würth Elektronik eiSos GmbH & Co. KG components in safety-critical applications

Product specific:

Follow all instructions mentioned in the datasheet, especially:

- The solder profile has to comply with the technical reflow or wave soldering specification, otherwise this will void the warranty.
- All products are supposed to be used before the end of the period of 12 months based on the product date-code.
- Violation of the technical product specifications such as exceeding the absolute maximum ratings will void the warranty.
- It is also recommended to return the body to the original moisture proof bag and reseal the moisture proof bag again.
- ESD prevention methods need to be followed for manual handling and processing by machinery.

Disclaimer:

This electronic component has been designed and developed for usage in general electronic equipment only. This product is not authorized for use in equipment where a higher safety standard and reliability standard is especially required or where a failure of the product is reasonably expected to cause severe personal injury or death, unless the parties have executed an agreement specifically governing such use. Moreover Würth Elektronik eiSos GmbH & Co. KG products are neither designed nor intended for use in areas such as military, aerospace, aviation, nuclear control, submarine, transportation (automotive control, train control, ship control), transportation signal, disaster prevention, medical, public information network etc. Würth Elektronik eiSos GmbH & Co. KG must be informed about the intent of such usage before the design-in stage. In addition, sufficient reliability evaluation checks for safety must be performed on every electronic component which is used in electrical circuits that require high safety and reliability functions or performance. These cautions and warnings comply with the state of the scientific and technical knowledge and are believed to be accurate and reliable. However, no responsibility is assumed for inaccuracies or incompleteness.

27 IMPORTANT NOTES

General Customer Responsibility

Some goods within the product range of Würth Elektronik eiSos GmbH & Co. KG contain statements regarding general suitability for certain application areas. These statements about suitability are based on our knowledge and experience of typical requirements concerning the areas, serve as general guidance and cannot be estimated as binding statements about the suitability for a customer application. The responsibility for the applicability and use in a particular customer design is always solely within the authority of the customer. Due to this fact it is up to the customer to evaluate, where appropriate to investigate and decide whether the device with the specific product characteristics described in the product specification is valid and suitable for the respective customer application or not. Accordingly, the customer is cautioned to verify that the datasheet is current before placing orders.

Customer Responsibility Related to Specific, in Particular Safety-Relevant, Applications

It has to be clearly pointed out that the possibility of a malfunction of electronic components or failure before the end of the usual lifetime cannot be completely eliminated in the current state of the art, even if the products are operated within the range of the specifications. In certain customer applications requiring a very high level of safety and especially in customer applications in which the malfunction or failure of an electronic component could endanger human life or health it must be ensured by most advanced technological aid of suitable design of the customer application that no injury or damage is caused to third parties in the event of malfunction or failure of an electronic component.

Best Care and Attention

Any product-specific notes, warnings and cautions must be strictly observed. Any disregard will result in the loss of warranty.

Customer Support for Product Specifications

Some products within the product range may contain substances which are subject to restrictions in certain jurisdictions in order to serve specific technical requirements. Necessary information is available on request. In this case the field sales engineer or the internal sales person in charge should be contacted who will be happy to support in this matter.

Product R&D

Due to constant product improvement product specifications may change from time to time. As a standard reporting procedure of the Product Change Notification (PCN) according to the JEDEC-Standard we inform about minor and major changes. In case of further queries regarding the PCN, the field sales engineer or the internal sales person in charge should be contacted. The basic responsibility of the customer as per Section 1 and 2 remains unaffected.

Product Life Cycle

Due to technical progress and economical evaluation we also reserve the right to discontinue production and delivery of products. As a standard reporting procedure of the Product Termination Notification (PTN) according to the JEDEC Standard we will inform at an early stage about inevitable product discontinuance. According to this we cannot guarantee that all products within our product range will always be available. Therefore it needs to be verified with the field sales engineer or the internal sales person in charge about the current product availability expectancy before or when the product for application design-in disposal is considered. The approach named above does not apply in the case of individual agreements deviating from the foregoing for customer-specific products.

Property Rights

All the rights for contractual products produced by Würth Elektronik eiSos GmbH & Co. KG on the basis of ideas, development contracts as well as models or templates that are subject to copyright, patent or commercial protection supplied to the customer will remain with Würth Elektronik eiSos GmbH & Co. KG. Würth Elektronik eiSos GmbH & Co. KG does not warrant or represent that any license, either expressed or implied, is granted under any patent right, copyright, mask work right, or other intellectual property right relating to any combination, application, or process in which Würth Elektronik eiSos GmbH & Co. KG components or services are used.

General Terms and Conditions

Unless otherwise agreed in individual contracts, all orders are subject to the current version of the "General Terms and Conditions of Würth Elektronik eiSos Group", last version available at www.we-online.com.

Looking for pricing, stock, or lifecycle information?

Click below to explore more details on WIN SOURCE:

- ⊖ [View 171033801 on WIN SOURCE](#)
- ⊖ [Wurth Electronics Inc Information](#)

Optimize Your Supply Chain with WIN SOURCE Solutions

- ✓ Global Sourcing Solution
- ✓ Obsolete Management
- ✓ Cost Control Management
- ✓ Shortage Management
- ✓ Alternative Solution
- ✓ Excess Inventory Management