

- I/O isolation 1500 VDC
- Unregulated outputs
- Single and dual output models
- Input voltage 5, 12 and 24 VDC
- High efficiency up to 80%
- Operating temperature range -40°C to +90°C
- High accuracy of pin co-planarity
- Qualified for leadfree reflow solder process according IPC/JEDEC J-STD-020C
- Available in tape and reel package
- 3-year product warranty

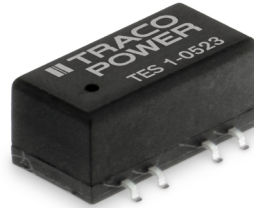

With their small footprint these 1 Watt DC/DC converters are an ideal and economical solution for many applications where an isolated voltage is required. Typical applications are ground loop elimination, noise reduction, voltage isolation in digital interfaces and voltage conversion in distributed power systems. With a new package design these converters are qualified for the higher temperatures requested by lead-free reflow solder processes. For automated SMD production lines the devices can be supplied in standard tape and reel package.

### Models

Order Code	Input Voltage Range	Output 1		Output 2		Efficiency typ.
		Vnom	I <sub>max</sub>	Vnom	I <sub>max</sub>	
TES 1-0510	4.5 - 5.5 VDC (5 VDC nom.)	3.3 VDC	300 mA			73 %
TES 1-0511		5 VDC	200 mA			78 %
TES 1-0519		9 VDC	110 mA			78 %
TES 1-0512		12 VDC	84 mA			78 %
TES 1-0513		15 VDC	67 mA			79 %
TES 1-0521		+5 VDC	100 mA	-5 VDC	100 mA	74 %
TES 1-0522		+12 VDC	42 mA	-12 VDC	42 mA	78 %
TES 1-0523		+15 VDC	33 mA	-15 VDC	33 mA	78 %
TES 1-1211	10.8 - 13.2 VDC (12 VDC nom.)	5 VDC	200 mA			76 %
TES 1-1219		9 VDC	110 mA			78 %
TES 1-1212		12 VDC	84 mA			79 %
TES 1-1213		15 VDC	67 mA			80 %
TES 1-1221		+5 VDC	100 mA	-5 VDC	100 mA	74 %
TES 1-1222		+12 VDC	42 mA	-12 VDC	42 mA	78 %
TES 1-1223		+15 VDC	33 mA	-15 VDC	33 mA	79 %
TES 1-2411		21.6 - 26.4 VDC (24 VDC nom.)	5 VDC	200 mA		
TES 1-2419	9 VDC		110 mA			77 %
TES 1-2412	12 VDC		84 mA			77 %
TES 1-2413	15 VDC		67 mA			79 %
TES 1-2421	+5 VDC		100 mA	-5 VDC	100 mA	73 %
TES 1-2422	+12 VDC		42 mA	-12 VDC	42 mA	78 %
TES 1-2423	+15 VDC		33 mA	-15 VDC	33 mA	78 %

### Input Specifications

Input Current	- At no load	5 Vin models: <b>30 mA typ.</b> 12 Vin models: <b>15 mA typ.</b> 24 Vin models: <b>8 mA typ.</b>
	- At full load	5 Vin models: <b>260 mA max.</b> 12 Vin models: <b>110 mA max.</b> 24 Vin models: <b>55 mA max.</b>
Surge Voltage		5 Vin models: <b>9 VDC max.</b> (1 s max.) 12 Vin models: <b>18 VDC max.</b> (1 s max.) 24 Vin models: <b>30 VDC max.</b> (1 s max.)
Recommended Input Fuse		(The need of an external fuse has to be assessed in the final application.)
Input Filter		Internal Capacitor

### Output Specifications

Voltage Set Accuracy		<b>±3% max.</b> (at 60% load, 3.3 & 5 Vout models) <b>±3% max.</b> (at 100% load, other output models)
Regulation (Unregulated)	- Input Variation (1% Vin step) - Load Variation - Voltage Balance (symmetrical load)	single output models: <b>1.5% max.</b> dual output models: <b>1.5% max.</b> See application note: <a href="http://www.tracopower.com/tes1-cc">www.tracopower.com/tes1-cc</a> dual output models: <b>1% max.</b>
Ripple and Noise	- 20 MHz Bandwidth	<b>120 mVp-p max.</b>
Capacitive Load		<b>33 µF max.</b>
Minimum Load		See application note: <a href="http://www.tracopower.com/tes1-cc">www.tracopower.com/tes1-cc</a> (Operation at lower load will not damage the converter, but it may not meet all specifications)
Temperature Coefficient		<b>±0.02 %/K max.</b>
Start-up Time		<b>400 ms max.</b>
Short Circuit Protection		Limited 0.5 s max., Automatic recovery

### Safety Specifications

Standards	- IT / Multimedia Equipment	Designed for IEC/EN/UL 62368-1 (not certified)
-----------	-----------------------------	------------------------------------------------

### General Specifications

Relative Humidity		<b>95% max.</b> (non condensing)
Temperature Ranges	- Operating Temperature - Case Temperature - Storage Temperature	<b>-40°C to +90°C</b> <b>+105°C max.</b> <b>-50°C to +125°C</b>
Power Derating	- High Temperature	<b>3.3 %/K above 75°C</b> See application note: <a href="http://www.tracopower.com/tes1-cc">www.tracopower.com/tes1-cc</a>
Cooling System		Natural convection (20 LFM)
Regulator Topology		Push-Pull Converter
Switching Frequency		<b>50 - 140 kHz (PFM)</b> <b>100 kHz typ. (PFM)</b>
Insulation System		Functional Insulation
Isolation Test Voltage	- Input to Output, 60 s - Input to Output, 1 s	<b>1'500 VDC</b> <b>1'800 VDC</b>
Isolation Resistance	- Input to Output, 500 VDC	<b>1'000 MΩ min.</b>
Isolation Capacitance	- Input to Output, 100 kHz, 1 V	<b>40 pF typ.</b> <b>100 pF max.</b>
Reliability	- Calculated MTBF	<b>2'000'000 h</b> (MIL-HDBK-217F, ground benign)
Moisture Sensitivity (MSL)		<b>Level 2</b> (J-STD-033C)
Washing Process		Not allowed

All specifications valid at nominal voltage, resistive full load and +25°C after warm-up time, unless otherwise stated.

Housing Material	Non-conductive Plastic (UL 94 V-0 rated)	
Base Material	Non-conductive Plastic (UL 94 V-0 rated)	
Pin Material	Phosphor Bronze (C5191)	
Pin Foundation Plating	Copper (1 - 3 $\mu\text{m}$ )	
Pin Surface Plating	Tin (7.5 $\mu\text{m}$ min.), matte	
Housing Type	Plastic Case	
Mounting Type	PCB Mount	
Connection Type	SMD (Surface-Mount Device)	
Footprint Type	SMD8 (single output models) SMD10 (dual output models)	
Soldering Profile	Lead-Free Reflow Soldering (acc. J-STD-020E) 245°C max. (Tp) 30 s max. (tp, at Tp - 5°C)	
	See application note:	<a href="http://www.tracopower.com/info/reflow-soldering.pdf">www.tracopower.com/info/reflow-soldering.pdf</a>
Weight	- single output - dual output	1.7 g 2 g
Environmental Compliance	- REACH Declaration  - RoHS Declaration	<a href="http://www.tracopower.com/info/reach-declaration.pdf">www.tracopower.com/info/reach-declaration.pdf</a> REACH SVHC list compliant REACH Annex XVII compliant <a href="http://www.tracopower.com/info/rohs-declaration.pdf">www.tracopower.com/info/rohs-declaration.pdf</a> Exemptions: No Exemptions

### Additional Information

Supporting Documents	<a href="http://www.tracopower.com/overview/tes1">www.tracopower.com/overview/tes1</a>
Frequently Asked Questions	<a href="http://www.tracopower.com/glossary-faq">www.tracopower.com/glossary-faq</a>
Glossary	<a href="http://www.tracopower.com/info/glossary.pdf">www.tracopower.com/info/glossary.pdf</a>

### Outline Dimensions

#### Single Output Models

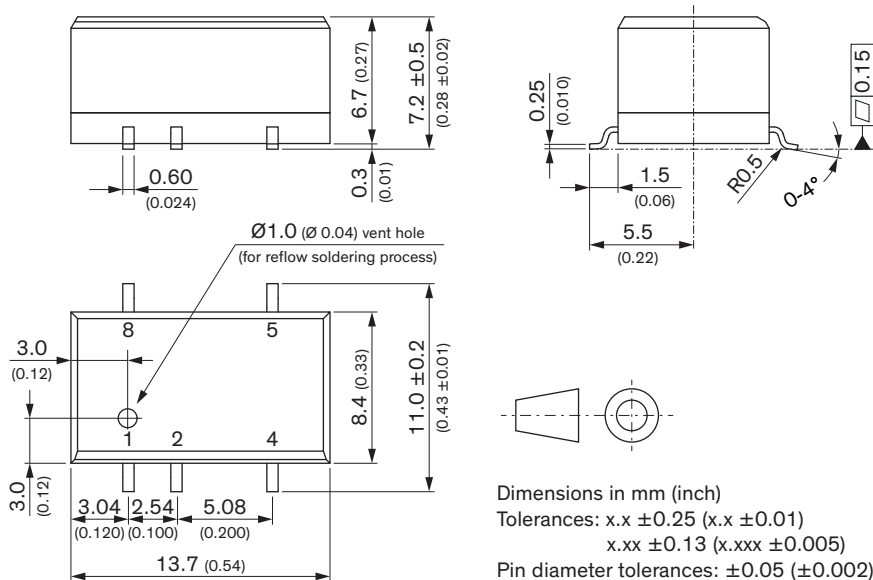

Pinout	
Pin	Single
1	-Vin (GND)
2	+Vin (Vcc)
4	-Vout
5	+Vout
8	NTC

NTC: Not to connect

All specifications valid at nominal voltage, resistive full load and +25°C after warm-up time, unless otherwise stated.

### Dual Output Models

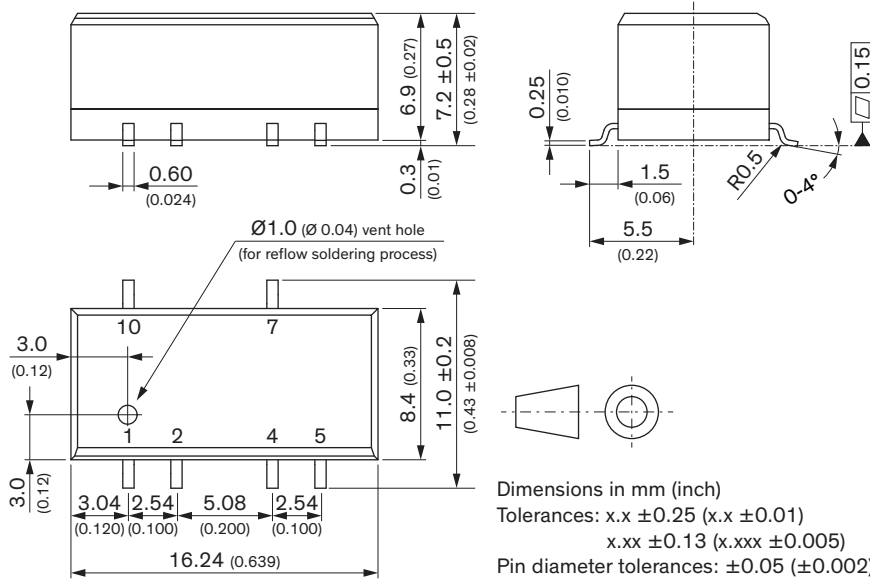

Pinout	
Pin	Dual
1	-Vin (GND)
2	+Vin (Vcc)
4	Common
5	-Vout
7	+Vout
10	NTC

NTC: Not to connect

### Recommended Solder Pad Layout

#### Single Output Models

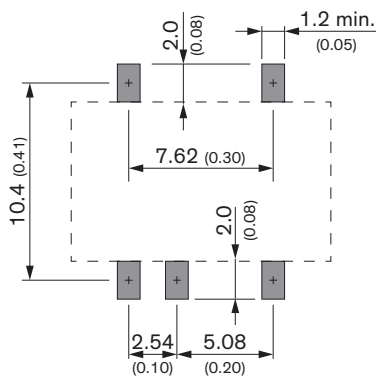

Dimensions in mm (inch)

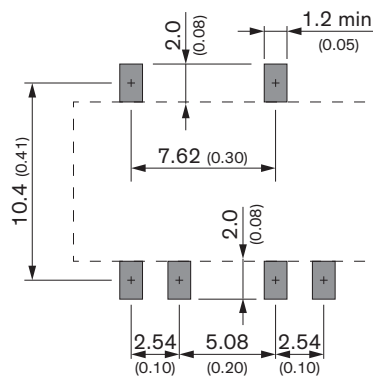

#### Dual Output Models



Dimensions in mm (inch)

## Looking for pricing, stock, or lifecycle information?

Click below to explore more details on WIN SOURCE:

-  [View TES 1-2423 on WIN SOURCE](#)
-  [Traco Power Information](#)

## Optimize Your Supply Chain with WIN SOURCE Solutions

-  Global Sourcing Solution
-  Obsolete Management
-  Cost Control Management
-  Shortage Management
-  Alternative Solution
-  Excess Inventory Management