

### Product Overview

Qorvo's QPA0708T is a power amplifier fabricated on Qorvo's 0.15um GaN on SiC process (QGaN15), mounted to a high thermal conductivity tab. Operating between 7.9 and 8.4 GHz, it achieves 36 dB small signal gain, 32 W linear power with -25 dBc intermodulation distortion products, and saturated output power of 72 W with a power-added efficiency of 49.3 %.

QPA0708T is ideally suited to support satellite communications.

To simplify system integration, the QPA0708T is fully matched to 50 ohms, with the DC shorted on the RF input port and integrated DC blocking caps on the RF output port.

The QPA0708T die is 100% DC and RF tested on-wafer to ensure compliance to electrical specifications.

Lead-free and RoHS compliant.



### Key Features

- Frequency Range: 7.9–8.4 GHz
- P<sub>SAT</sub> (P<sub>IN</sub>=18 dBm): 48.6 dBm
- PAE (P<sub>IN</sub>=18 dBm): 49.3 %
- Power Gain (P<sub>IN</sub>=18 dBm): 30.6 dB
- IMD3 (at 42 dBm/tone): -25 dBc
- Small Signal Gain: 36 dB
- Bias: V<sub>D</sub> = 26 V, I<sub>DQ</sub> = 904 mA
- Tab dimensions: 5.817 mm x 6.172 mm x 0.254 mm

*Performance is typical across frequency. Please reference electrical specification table and data plots for more details.*

### Functional Block Diagram

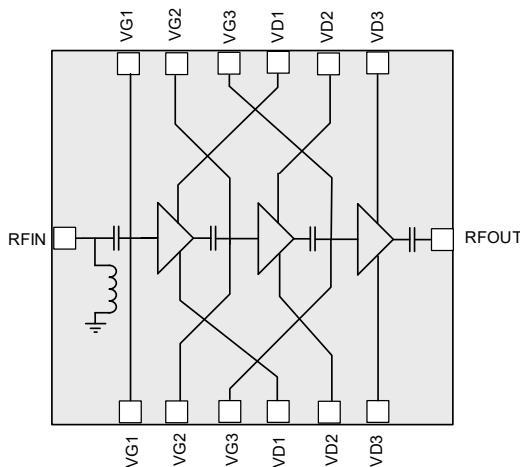

### Applications

- Satellite Communications

### Ordering Information

Part No.	Description
QPA0708T	7.9–8.4 GHz GaN Amplifier (20 Pcs.)
QPA0708TEVB	QPA0708T Evaluation Board

## Absolute Maximum Ratings

Parameter	Value / Range
Drain Voltage ( $V_D$ )	29.5 V
Gate Voltage Range ( $V_G$ )	-4 V to 0 V
Drain Current ( $I_{D1}$ ), Stage 1	0.36 A
Drain Current ( $I_{D2}$ ), Stage 2	1.6 A
Drain Current ( $I_{D2}$ ), Stage 3	11.52 A
Gate Current ( $I_G$ )	See plot pg. 18
Power Dissipation ( $P_{DISS}$ ), 85 °C	100 W
Input Power ( $P_{IN}$ ), 50 $\Omega$ , $V_D=22$ V, $I_{DQ}=280$ mA, 85 °C	29 dBm
Input Power ( $P_{IN}$ ), 3:1 VSWR, $V_D=22$ V, $I_{DQ}=280$ mA, 85 °C	25 dBm
Storage Temperature	-55 to +150 °C

Operation of this device outside the parameter ranges given above may cause permanent damage. These are stress ratings only, and functional operation of the device at these conditions is not implied.

## Recommended Operating Conditions

Parameter	Value / Range
Drain Voltage ( $V_D$ )	26
Drain Current, Total ( $I_{DQ}$ )	904 mA
Operating Temperature	-40 to +85 °C

Electrical specifications are measured at specified test conditions. Specifications are not guaranteed over all recommended operating conditions.

## Electrical Specifications

Parameter		Min	Typ	Max	Units
Operational Frequency		7.9		8.4	GHz
Saturated Output Power ( $P_{IN}=18$ dBm) <sup>1</sup>	7.90 GHz		48.6		dBm
	8.15 GHz		48.7		dBm
	8.40 GHz		48.6		dBm
Power Added Efficiency ( $P_{IN}=18$ dBm)	7.90 GHz		49.3		%
	8.15 GHz		49.4		%
	8.40 GHz		48.6		%
Small Signal Gain	7.90 GHz		37.7		dB
	8.15 GHz		36.7		dB
	8.40 GHz		36.2		dB
Input Return Loss	7.90 GHz		18		dB
	8.15 GHz		20		dB
	8.40 GHz		23		dB
Output Return Loss	7.90 GHz		12		dB
	8.15 GHz		13		dB
	8.40 GHz		15		dB
IMD3 ( $P_{OUT}/\text{Tone} = 42$ dBm, 10 MHz tone spacing)	7.90 GHz		-25.2		dBc
	8.15 GHz		-27.2		dBc
	8.40 GHz		-26.0		dBc
$P_{OUT}$ Temp. Coeff. (85 °C to 25 °C, $P_{IN} = 18$ dBm))			-0.023		dB/°C
Sm. Sig. Gain Temp. Coefficient (85 °C to -40 °C)			-0.073		dB/°C

Test conditions, unless otherwise noted:  $T = +25$  °C,  $V_D = 26$  V,  $I_{DQ} = 904$  mA  
All performance data presented is for the bare die

## Performance Plots – Large Signal

Test conditions, unless otherwise noted:  $V_D = 26\text{ V}$ ,  $I_{DQ} = 904\text{ mA}$ ,  $T = +25\text{ }^\circ\text{C}$ ,  $P_{IN} = 18\text{ dBm}$   
All performance data presented is for the bare die

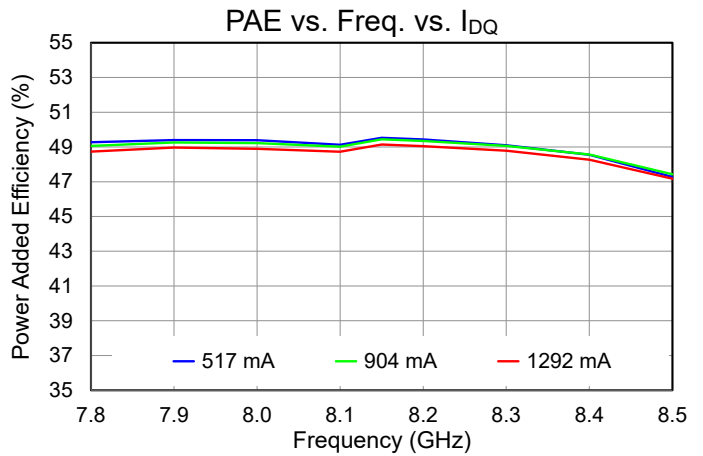
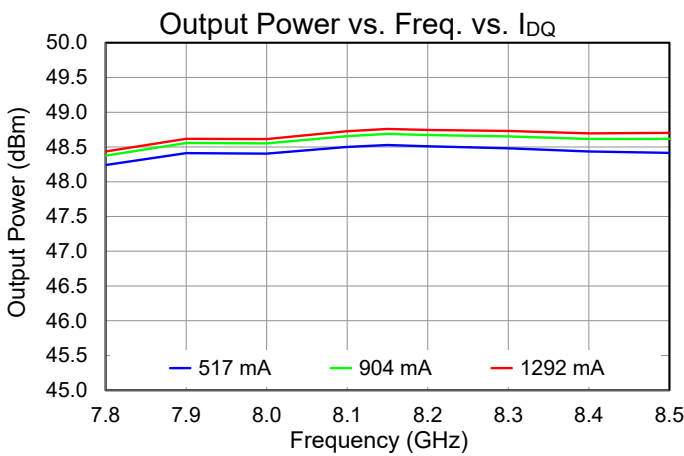
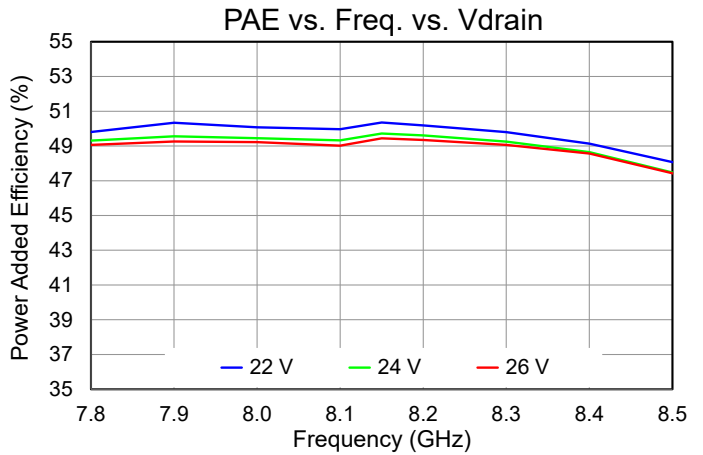
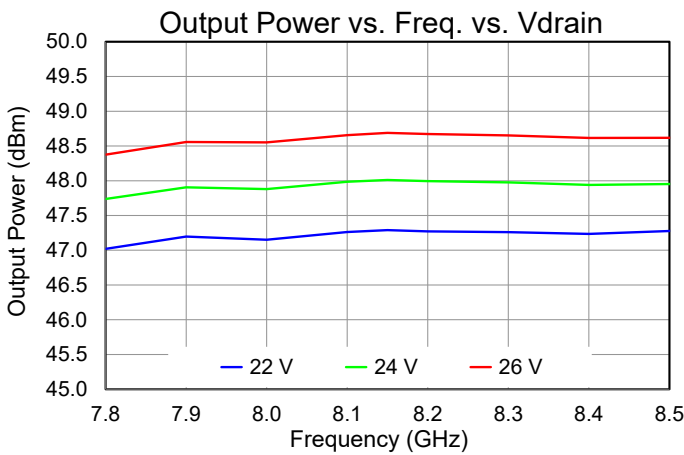
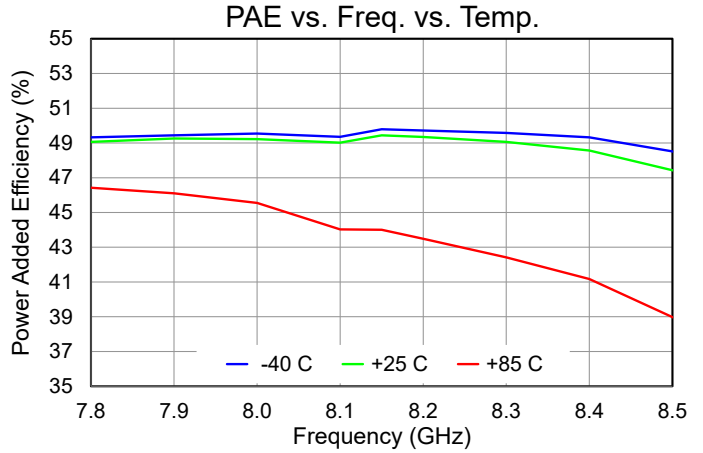
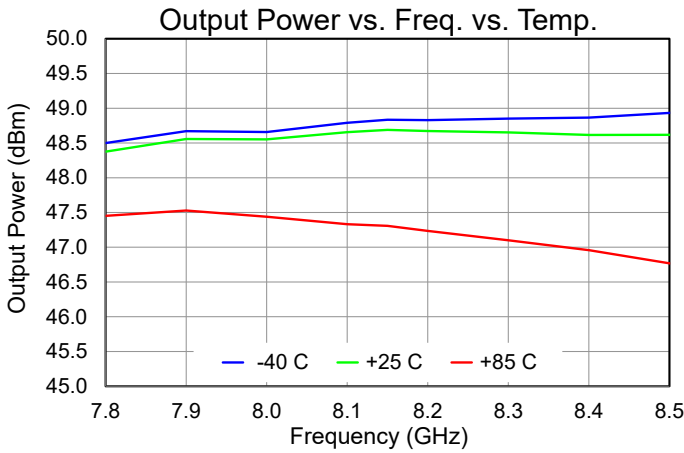

## Performance Plots – Large Signal

Test conditions, unless otherwise noted:  $V_D = 26\text{ V}$ ,  $I_{DQ} = 904\text{ mA}$ ,  $T = +25\text{ }^\circ\text{C}$ ,  $P_{IN} = 18\text{ dBm}$

All performance data presented is for the bare die

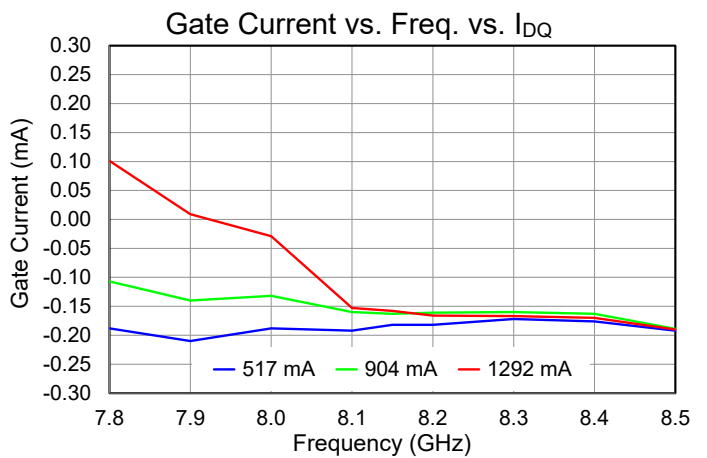
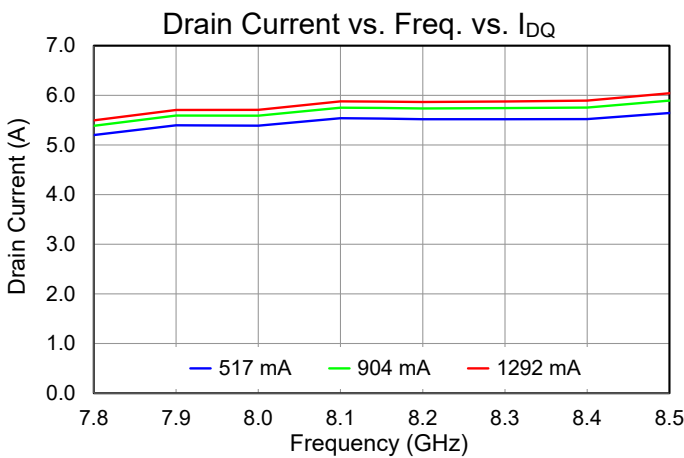
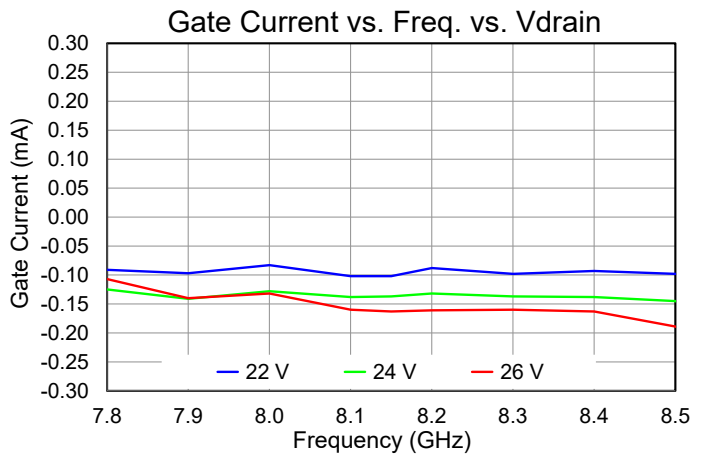
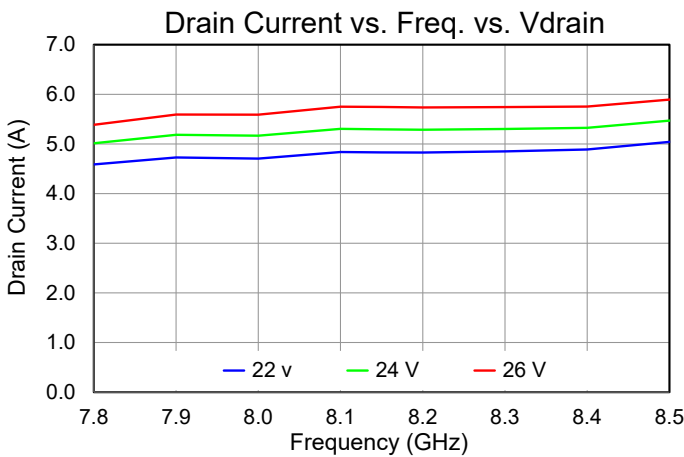
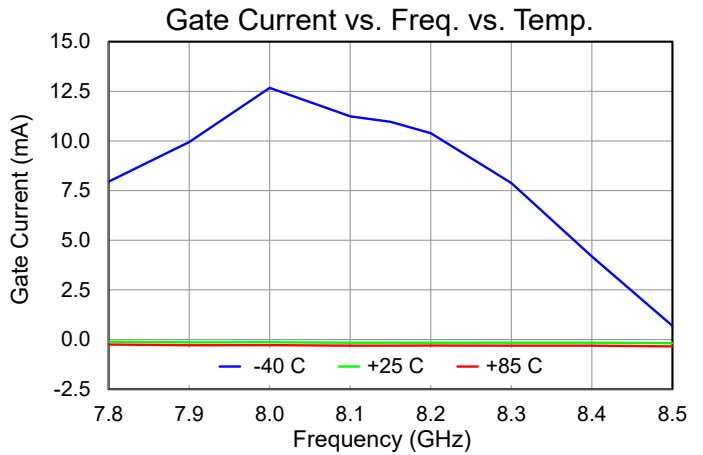
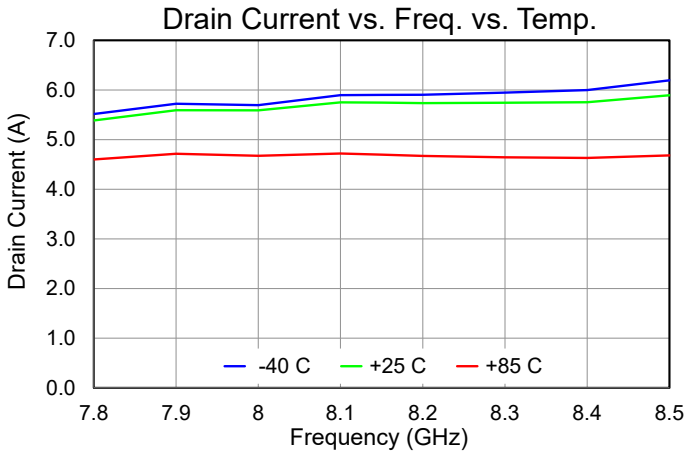

## Performance Plots – Large Signal

Test conditions, unless otherwise noted:  $V_D = 26\text{ V}$ ,  $I_{DQ} = 904\text{ mA}$ ,  $T = +25\text{ }^\circ\text{C}$   
All performance data presented is for the bare die

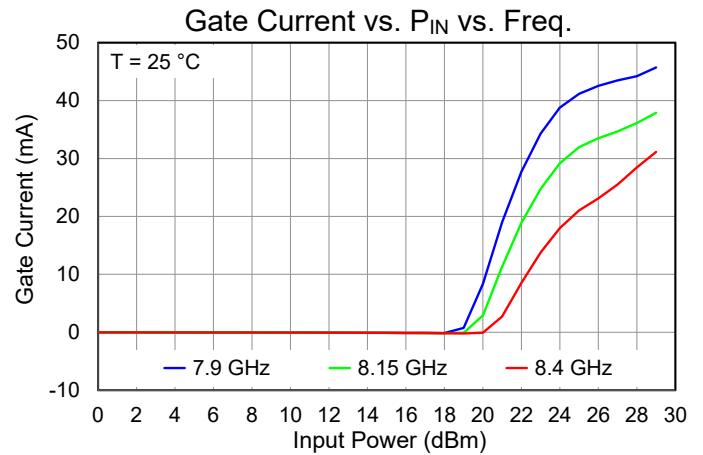
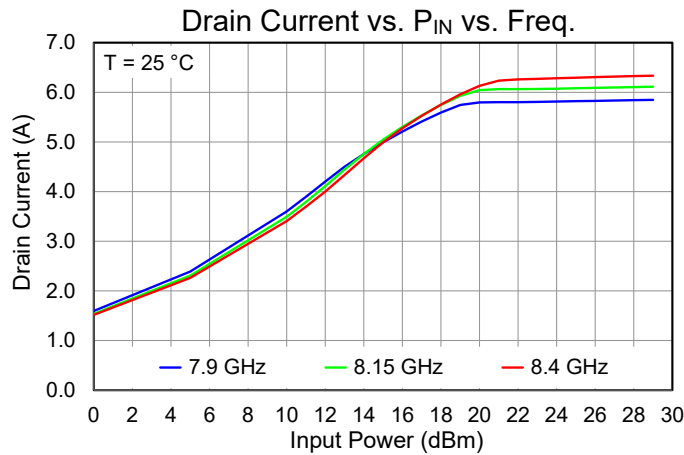
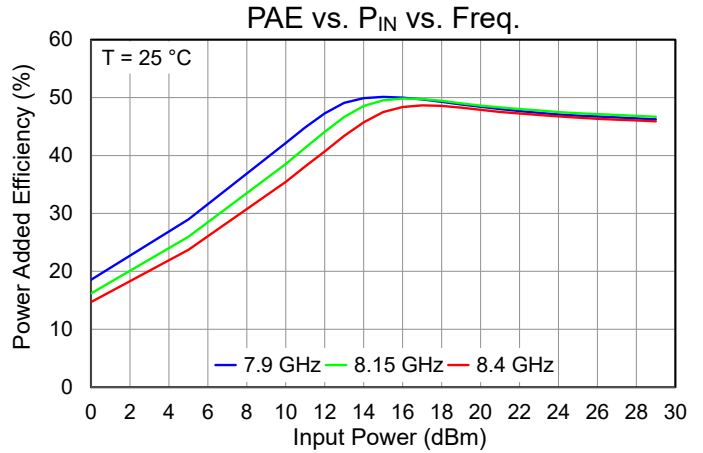
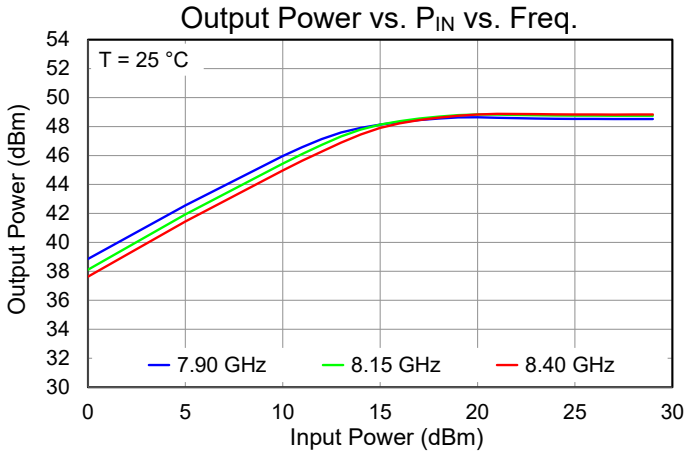

## Performance Plots – Large Signal

Test conditions, unless otherwise noted:  $V_D = 26\text{ V}$ ,  $I_{DQ} = 904\text{ mA}$ ,  $T = +25\text{ }^\circ\text{C}$   
All performance data presented is for the bare die

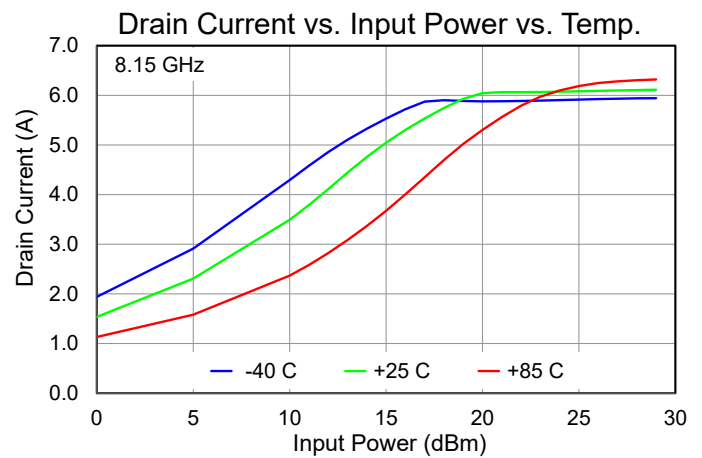
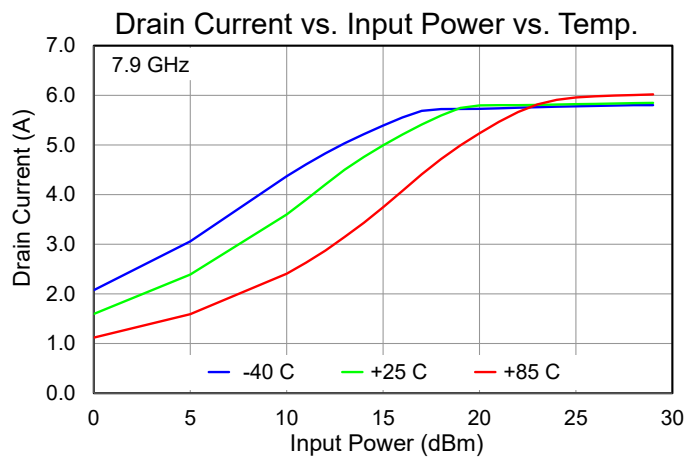
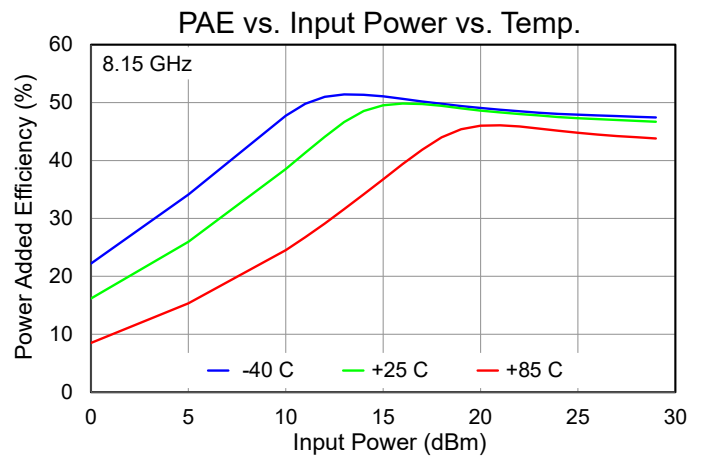
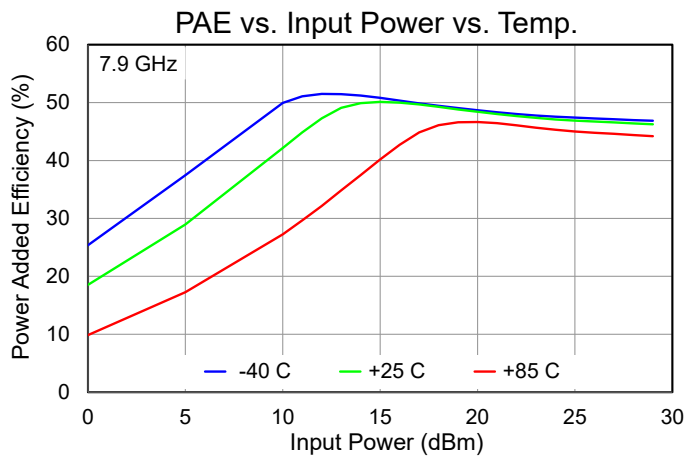
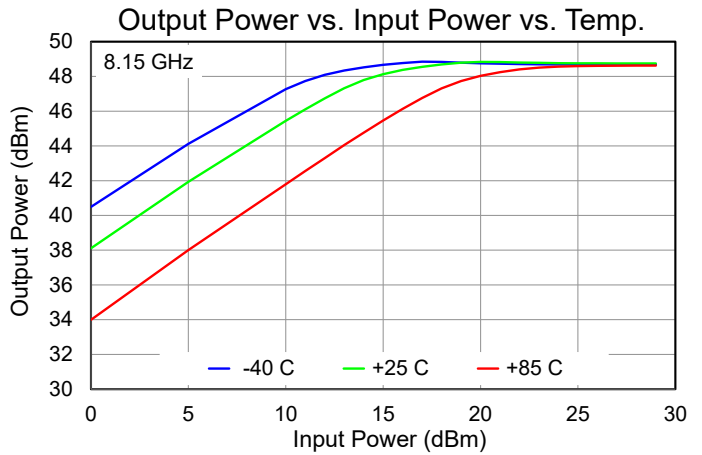
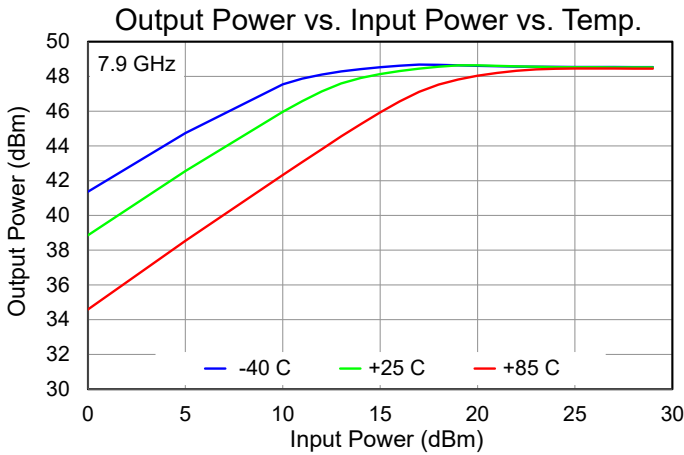

## Performance Plots – Large Signal

Test conditions, unless otherwise noted:  $V_D = 26\text{ V}$ ,  $I_{DQ} = 904\text{ mA}$ ,  $T = +25\text{ }^\circ\text{C}$   
All performance data presented is for the bare die

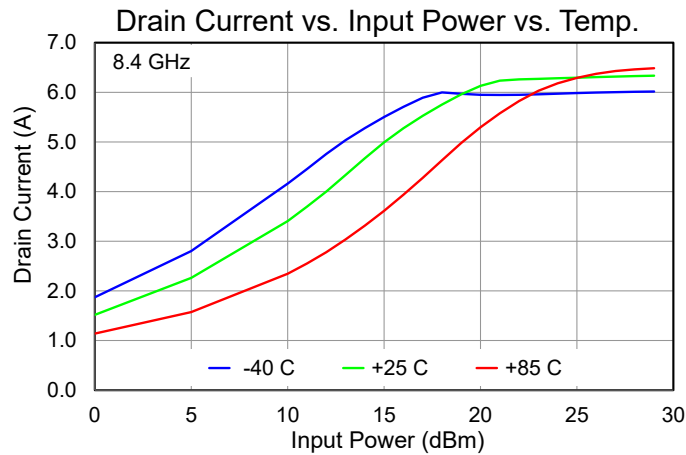
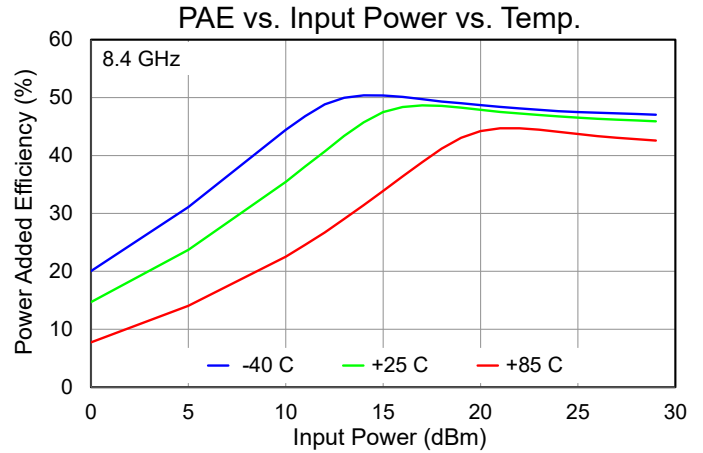
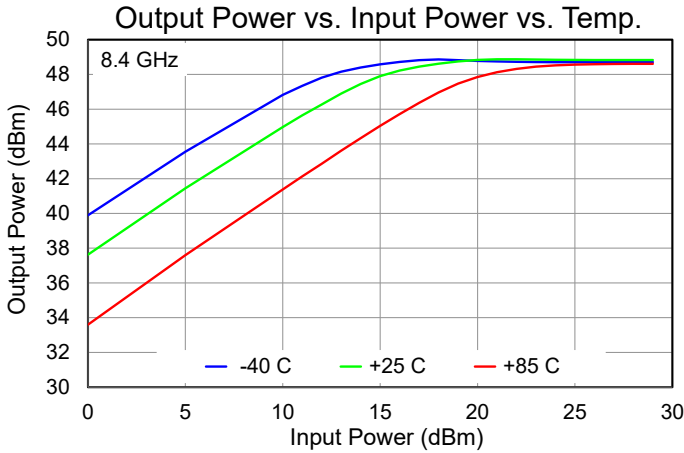

## Performance Plots – Large Signal

Test conditions, unless otherwise noted:  $V_D = 26\text{ V}$ ,  $I_{DQ} = 904\text{ mA}$ ,  $T = +25\text{ }^\circ\text{C}$   
All performance data presented is for the bare die

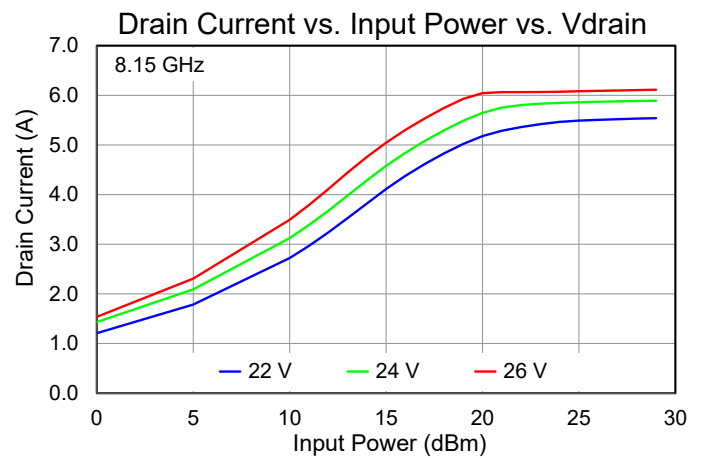
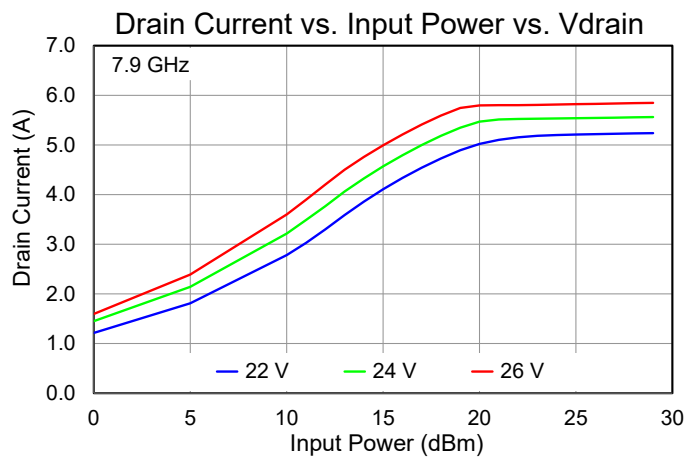
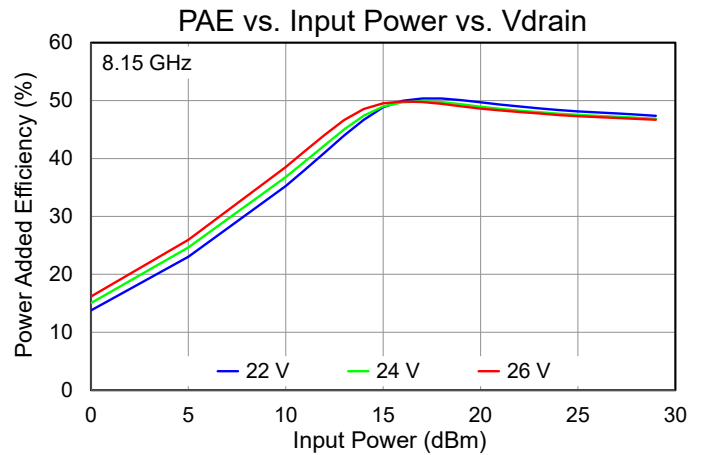
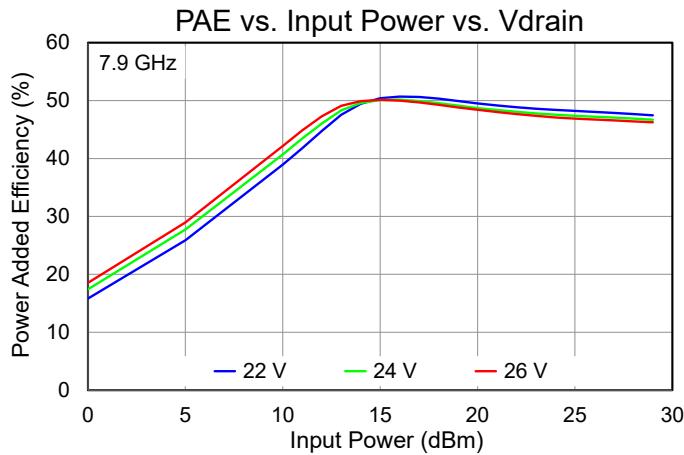
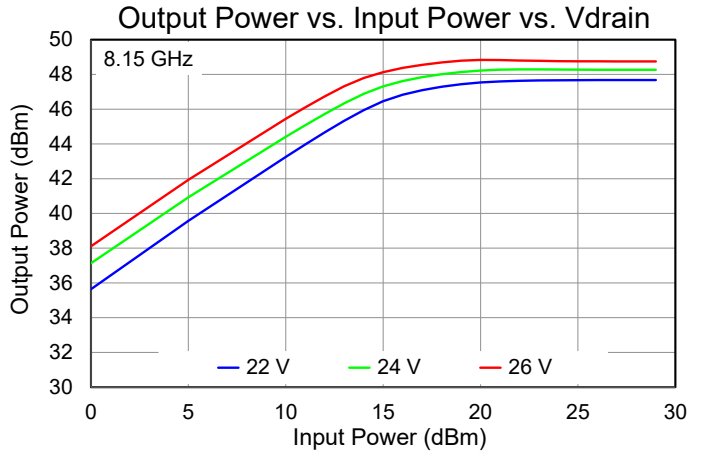
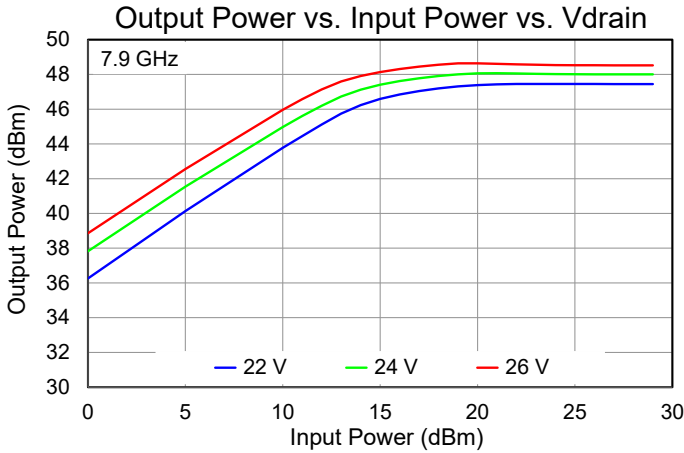

Performance Plots – Large Signal

Test conditions, unless otherwise noted:  $V_D = 26\text{ V}$ ,  $I_{DQ} = 904\text{ mA}$ ,  $T = +25\text{ }^\circ\text{C}$   
All performance data presented is for the bare die

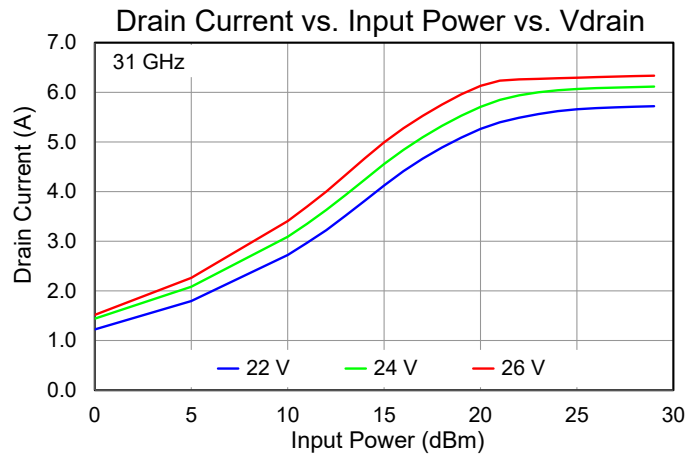
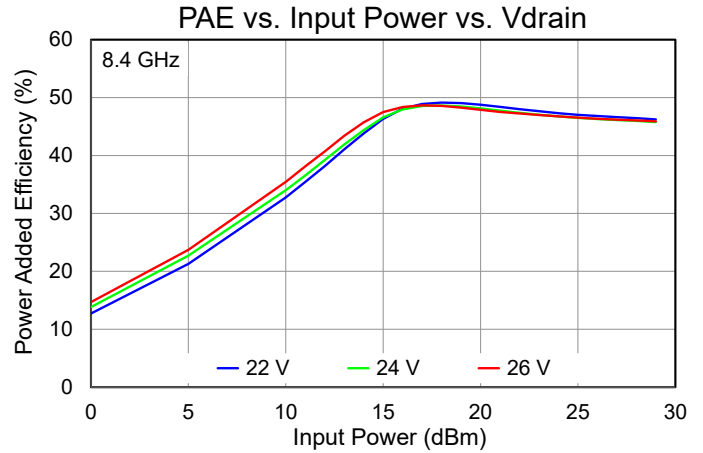
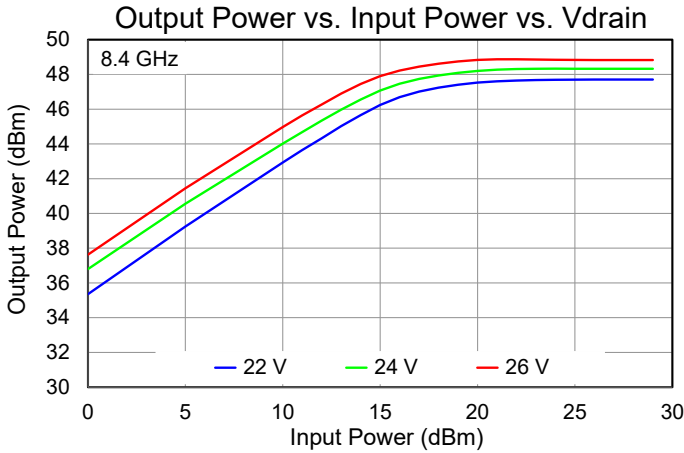

## Performance Plots – Large Signal

Test conditions, unless otherwise noted:  $V_D = 26\text{ V}$ ,  $I_{DQ} = 904\text{ mA}$ ,  $T = +25\text{ }^\circ\text{C}$   
 All performance data presented is for the bare die

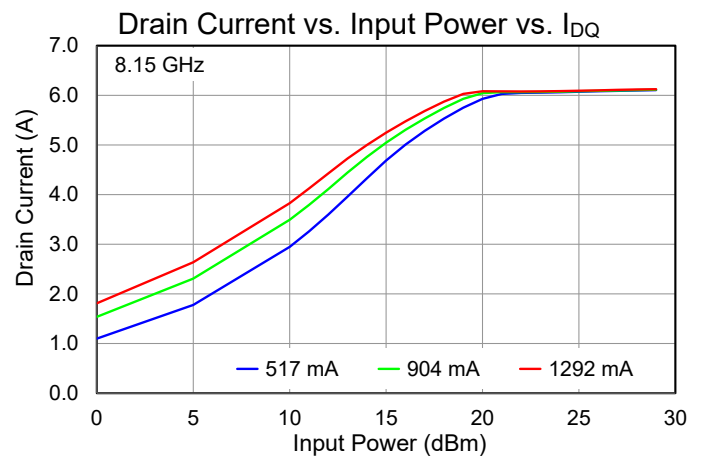
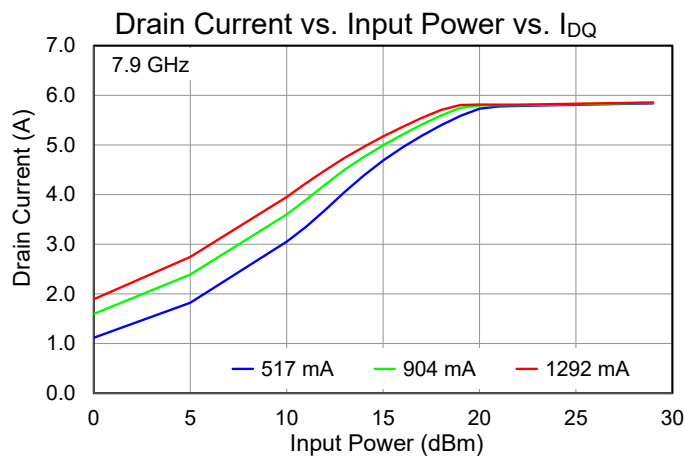
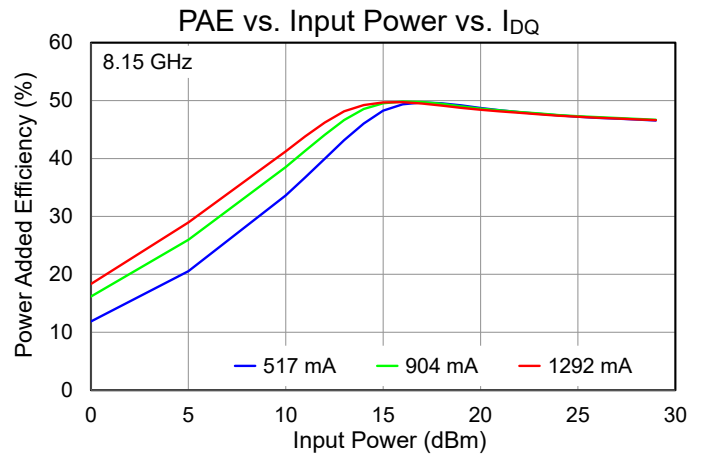
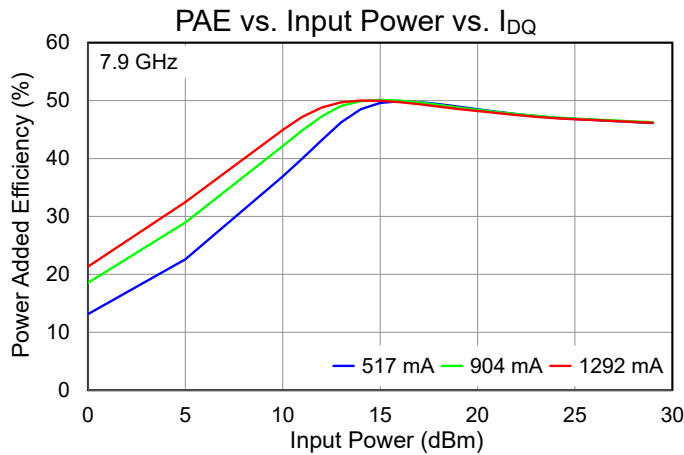
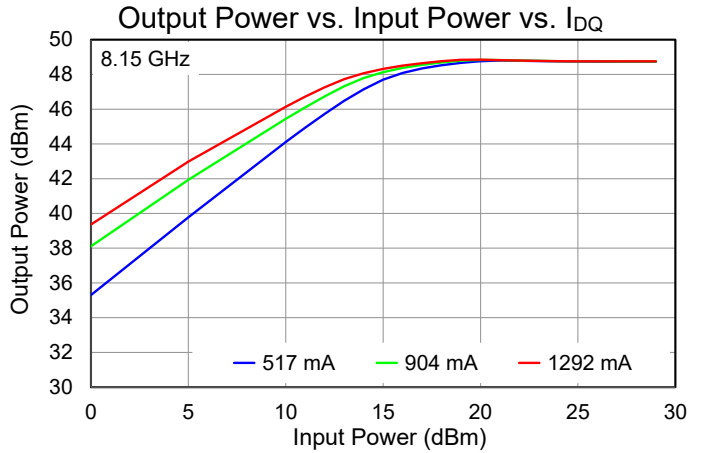
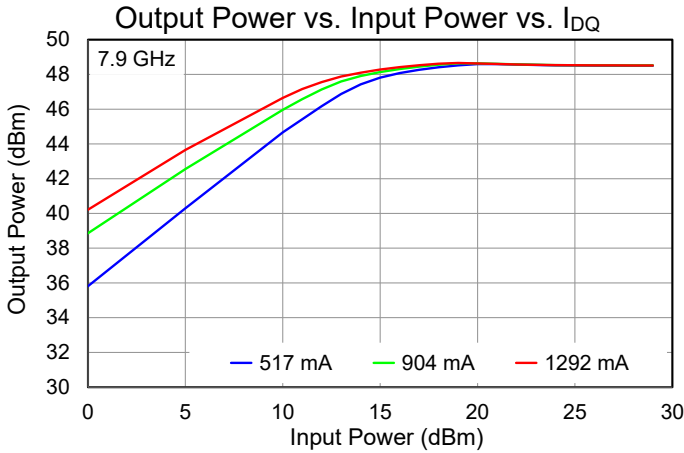

## Performance Plots – Large Signal

Test conditions, unless otherwise noted:  $V_D = 26\text{ V}$ ,  $I_{DQ} = 904\text{ mA}$ ,  $T = +25\text{ }^\circ\text{C}$   
All performance data presented is for the bare die

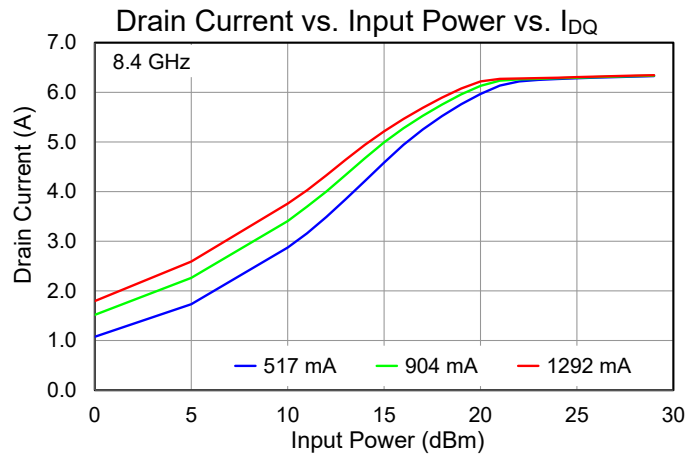
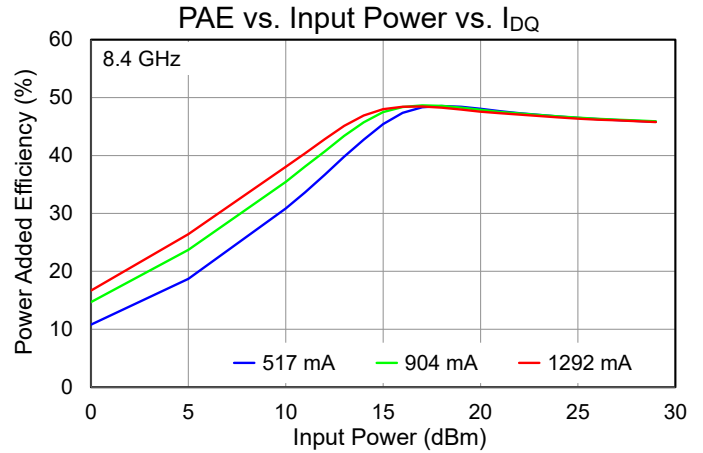
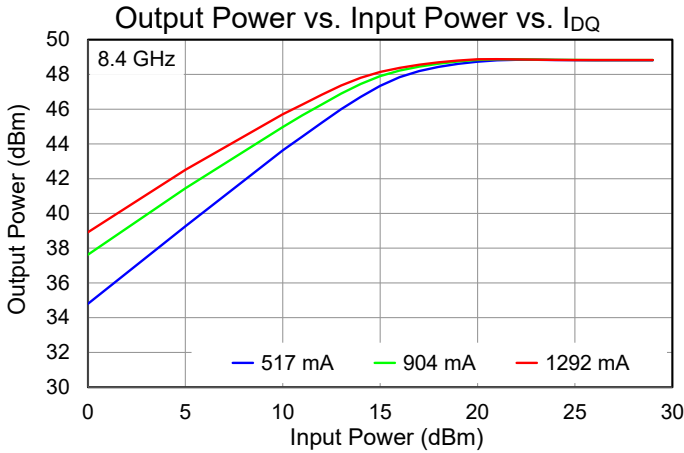

Performance Plots – 2<sup>ND</sup> Harmonic

Test conditions, unless otherwise noted:  $V_D = 26\text{ V}$ ,  $I_{DQ} = 904\text{ mA}$ ,  $T = +25\text{ }^\circ\text{C}$   
All performance data presented is for the bare die

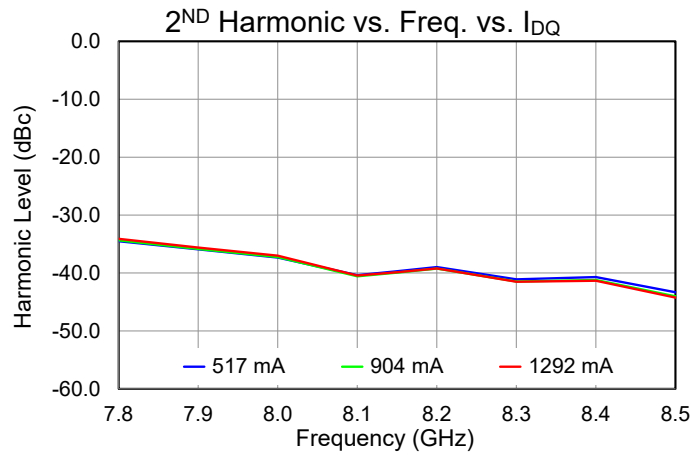
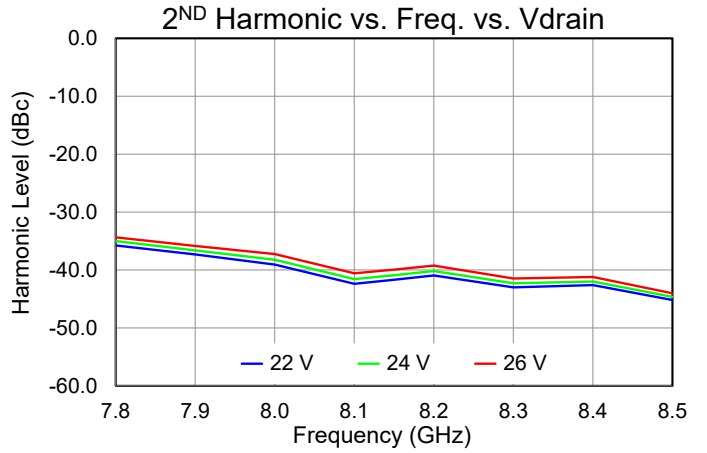
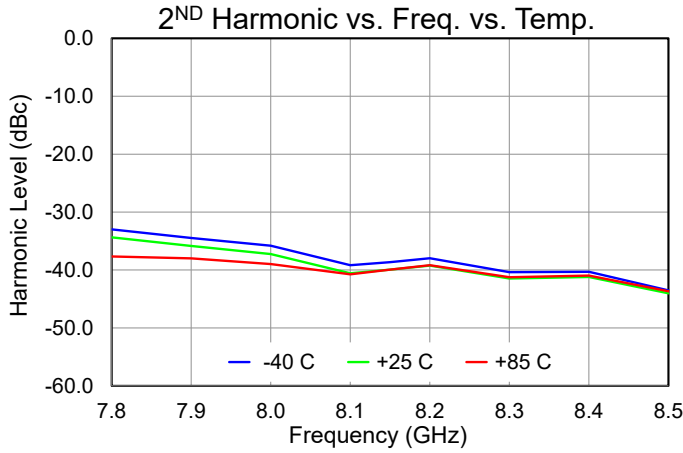

Performance Plots – Linearity

Test conditions, unless otherwise noted:  $V_D = 26\text{ V}$ ,  $I_{DQ} = 904\text{ mA}$ ,  $T = +25\text{ }^\circ\text{C}$ , Tone Spacing = 10 MHz  
All performance data presented is for the bare die

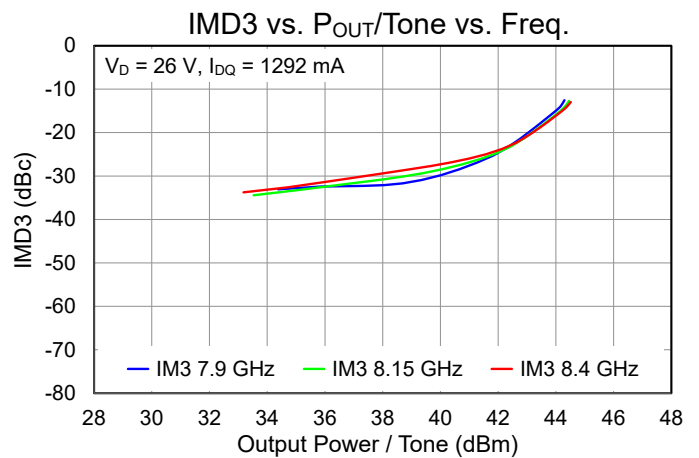
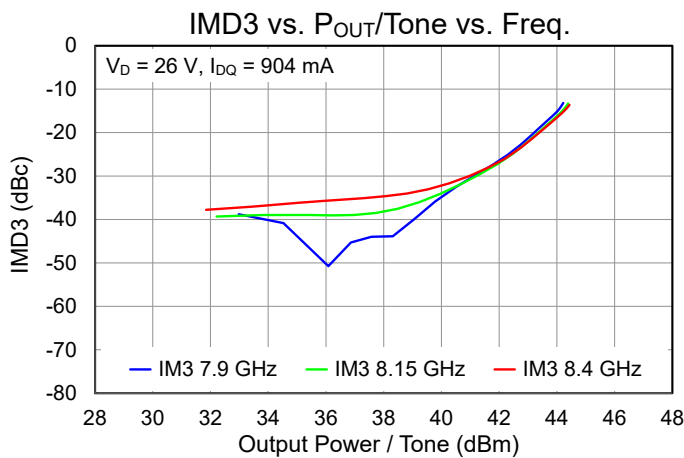
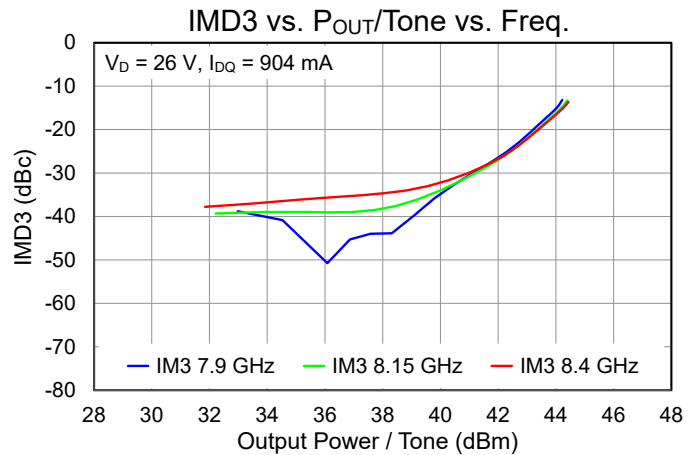
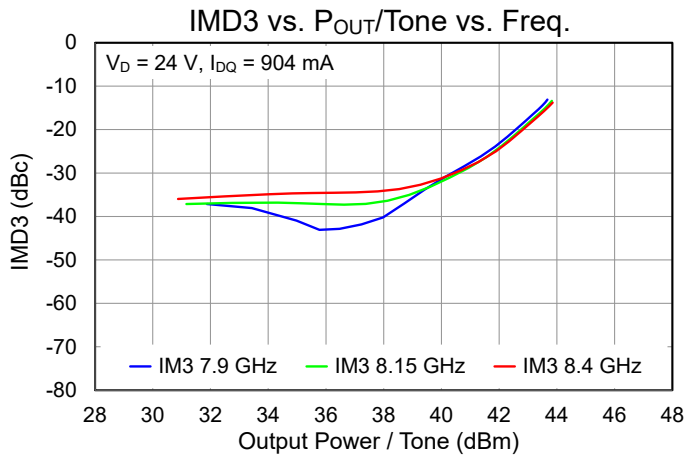
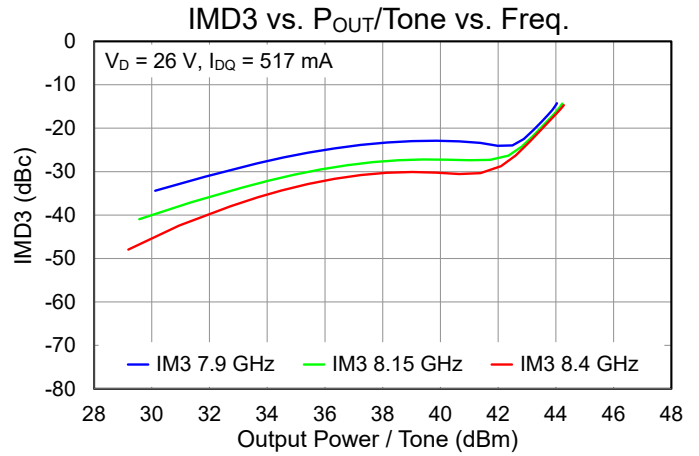
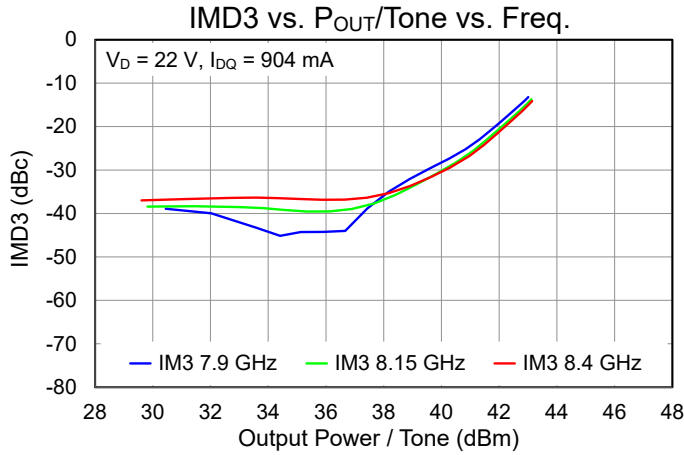

Performance Plots – Linearity

Test conditions, unless otherwise noted:  $V_D = 26\text{ V}$ ,  $I_{DQ} = 904\text{ mA}$ ,  $T = +25\text{ }^\circ\text{C}$ , Tone Spacing = 10 MHz  
All performance data presented is for the bare die

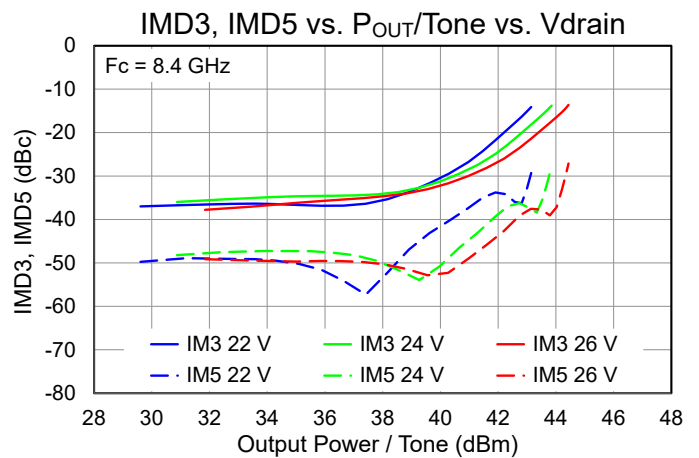
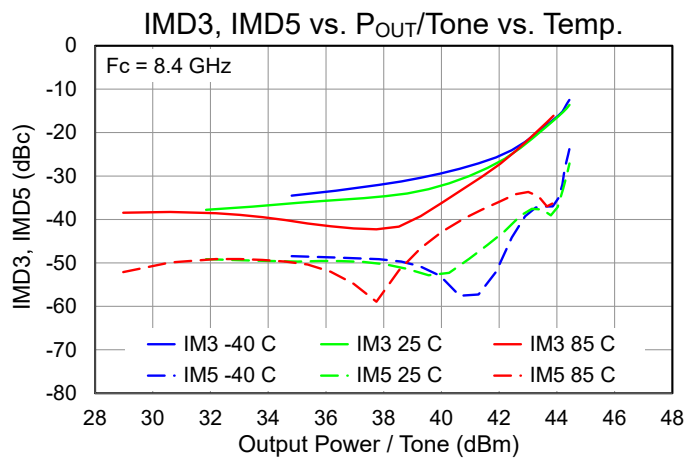
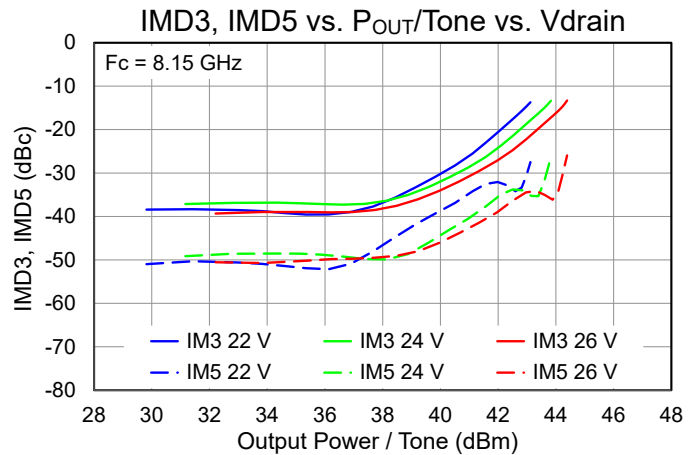
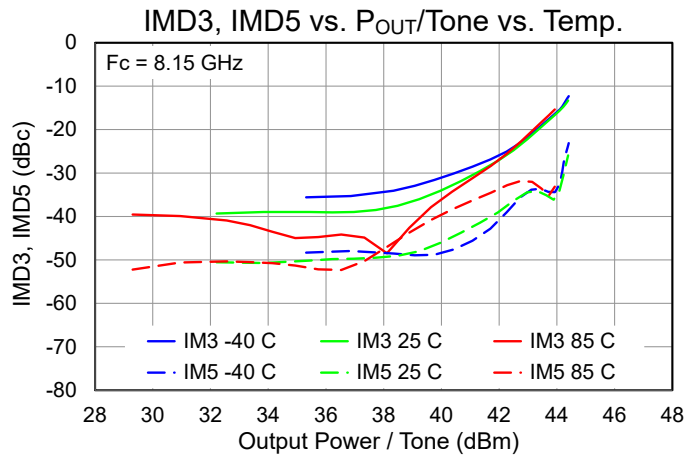
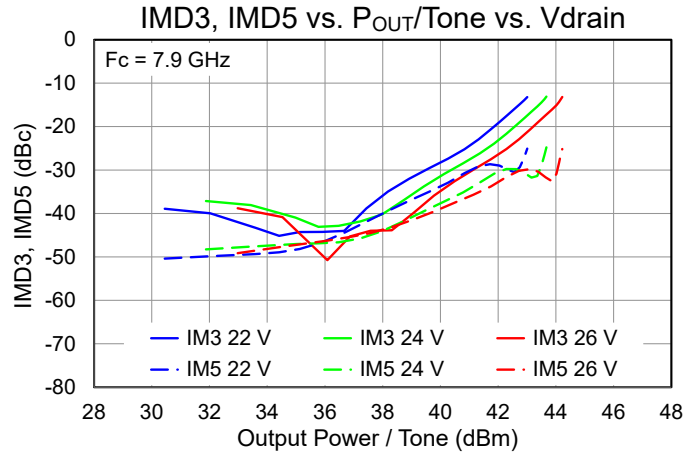
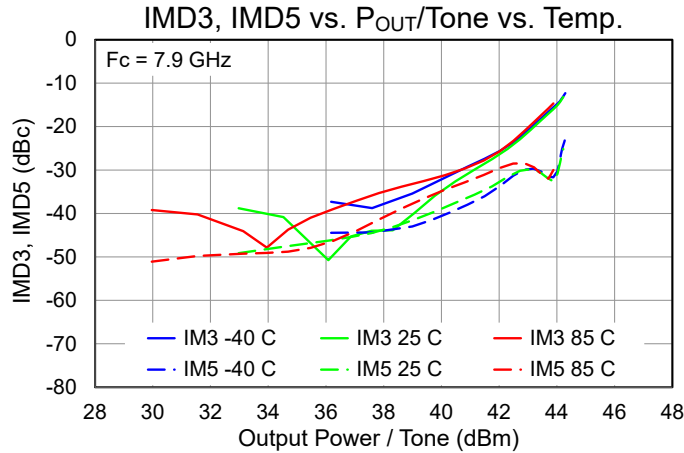

Performance Plots – Linearity

Test conditions, unless otherwise noted:  $V_D = 26\text{ V}$ ,  $I_{DQ} = 904\text{ mA}$ ,  $T = +25\text{ }^\circ\text{C}$ , Tone Spacing = 10 MHz  
All performance data presented is for the bare die

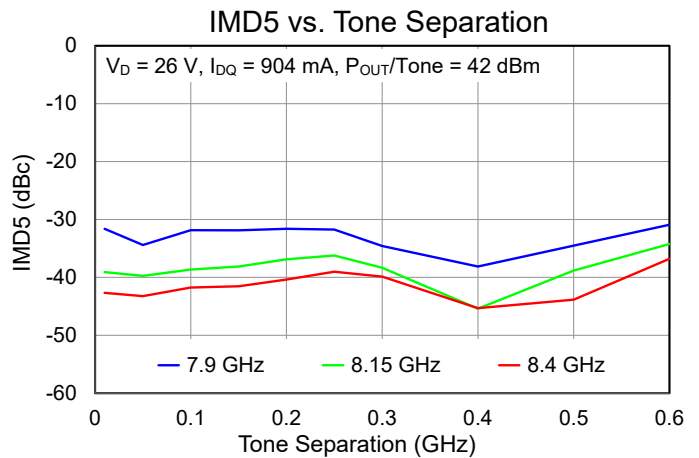
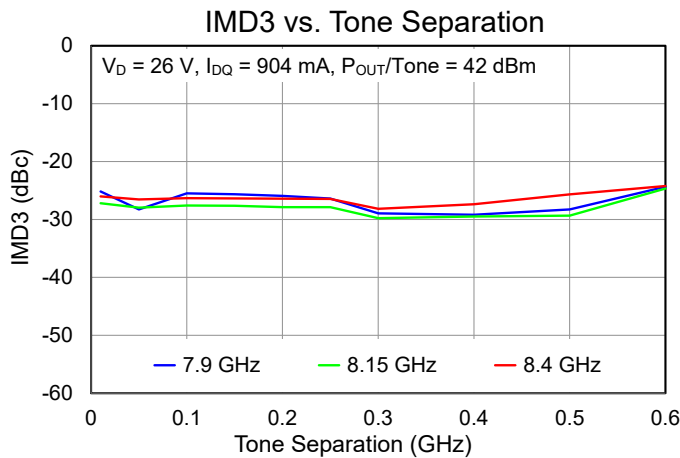
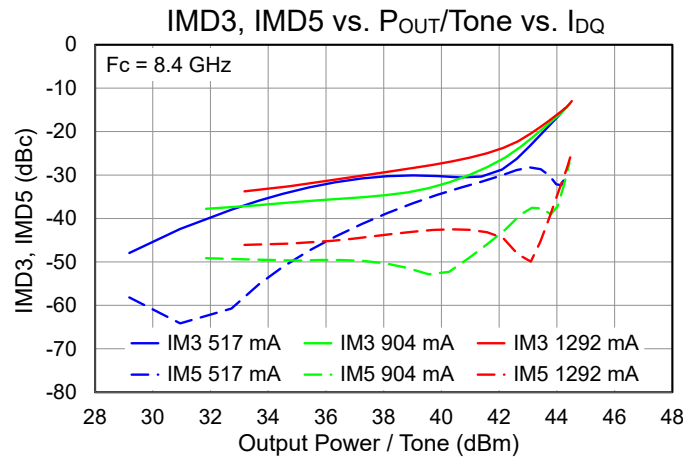
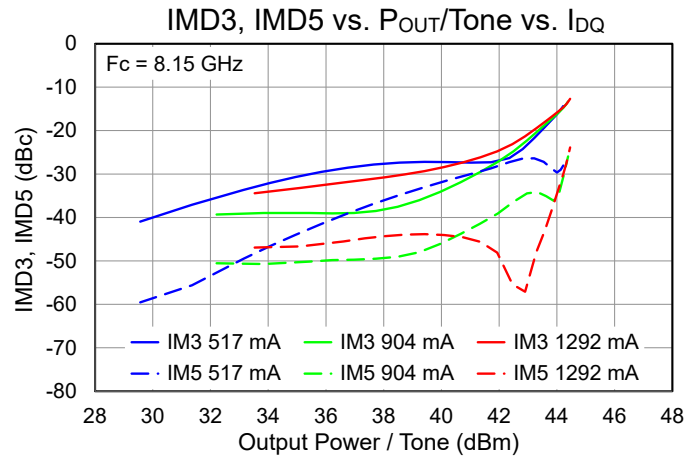
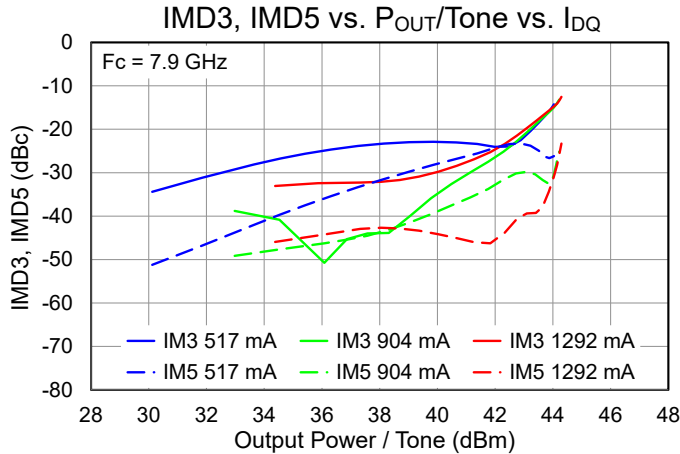

## Performance Plots – Small Signal

Test conditions, unless otherwise noted:  $V_D = 26\text{ V}$ ,  $I_{DQ} = 904\text{ mA}$ ,  $T = +25\text{ }^\circ\text{C}$   
All performance data presented is for the bare die

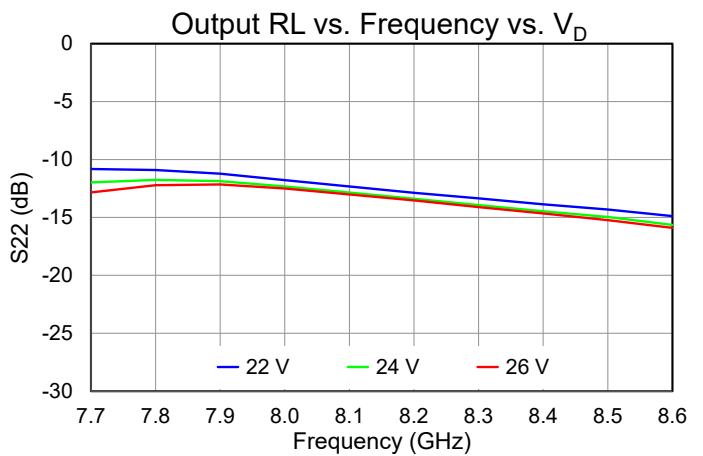
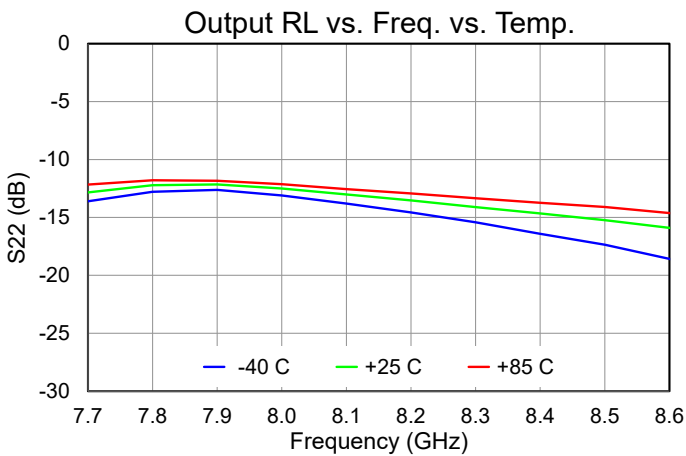
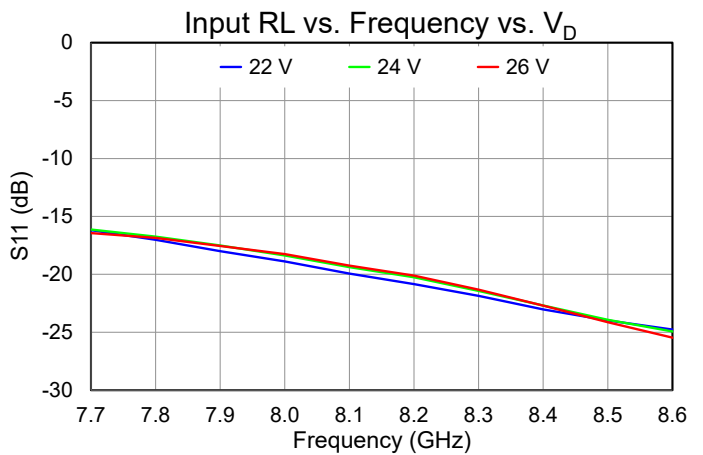
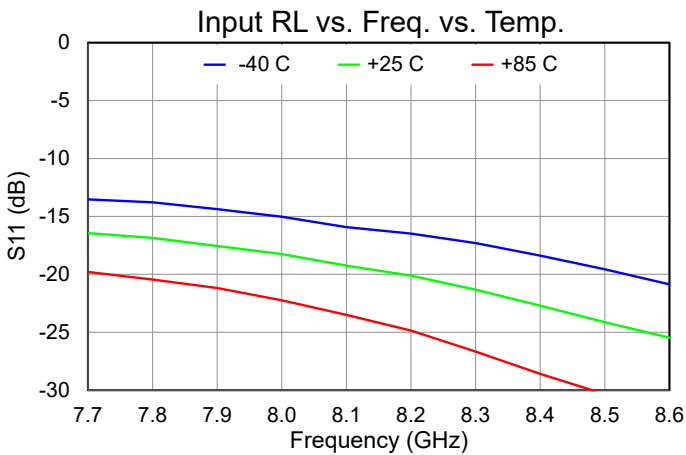
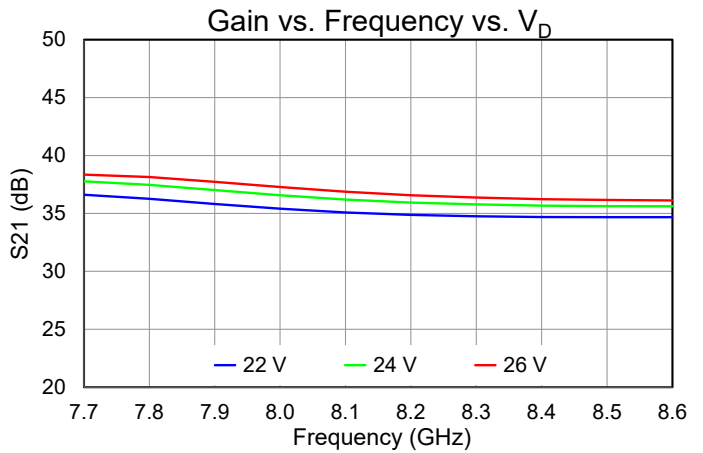
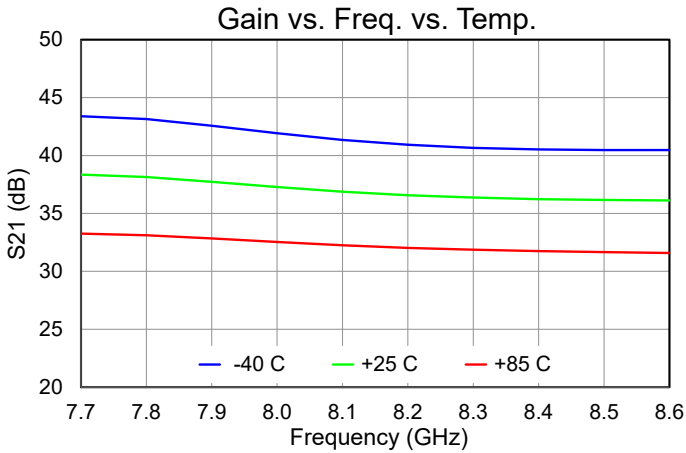

### Performance Plots – Small Signal

Test conditions, unless otherwise noted:  $V_D = 26\text{ V}$ ,  $I_{DQ} = 904\text{ mA}$ ,  $T = +25\text{ }^\circ\text{C}$   
 All performance data presented is for the bare die

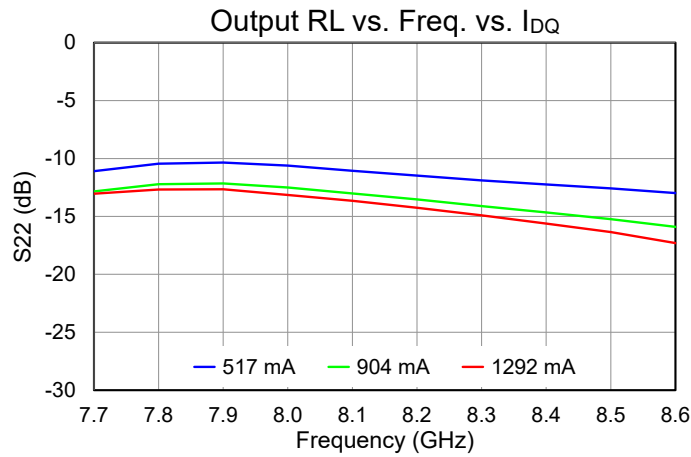
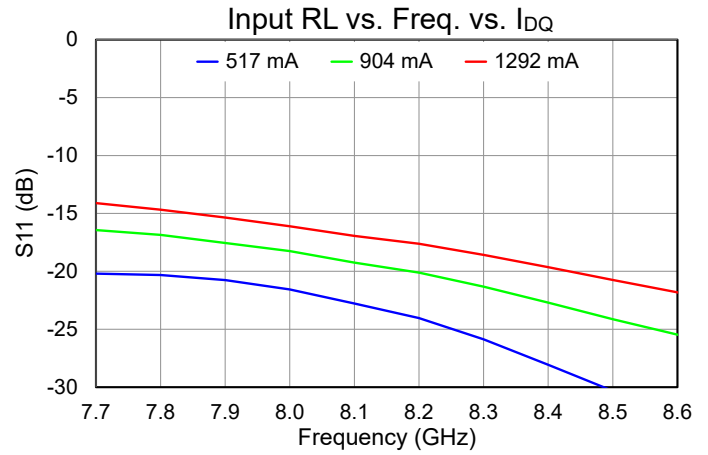
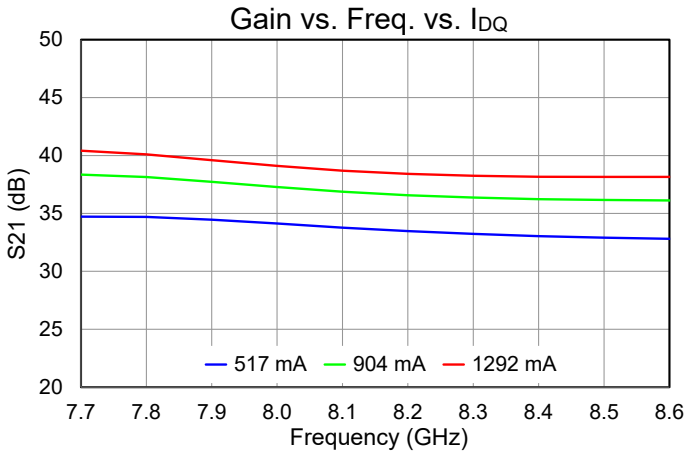

## Thermal and Reliability Information

Parameter	Test Conditions	Value	Units
Thermal Resistance ( $\theta_{JC}$ ) <sup>(1)</sup>	T <sub>base</sub> = 85 °C, V <sub>D</sub> = 26 V, I <sub>DQ</sub> = 904 mA, P <sub>DISS</sub> = 23.504 W, No RF (quiescent DC operation)	0.6351	°C/W
Channel Temperature, T <sub>CH</sub> (No RF) <sup>(2)</sup>		99.93	°C
Thermal Resistance ( $\theta_{JC}$ ) <sup>(1)</sup>	T <sub>base</sub> = 85 °C, V <sub>D</sub> = 26 V, I <sub>DQ</sub> = 940 mA, Freq = 8.4 GHz, I <sub>D_Drive</sub> = 4631 mA, P <sub>IN</sub> = 18 dBm, P <sub>OUT</sub> = 46.96 dBm, P <sub>DISS</sub> = 70.85 W	0.5699	°C/W
Channel Temperature, T <sub>CH</sub> (Under RF) <sup>(2)</sup>		125.4	°C

**Notes:**

1. Thermal resistance determined to the back of 20 mil CuMo carrier plate at 85 °C on die EVB
2. Data shown for bare die mounted onto 20 mil Cu-Mo carrier on the die EVB, not including the CMC tab
3. IR scan equivalent. Refer to the following document: [GaN Device Channel Temperature, Thermal Resistance, and Reliability Estimates](#)

## Dissipated Power and Maximum Gate Current

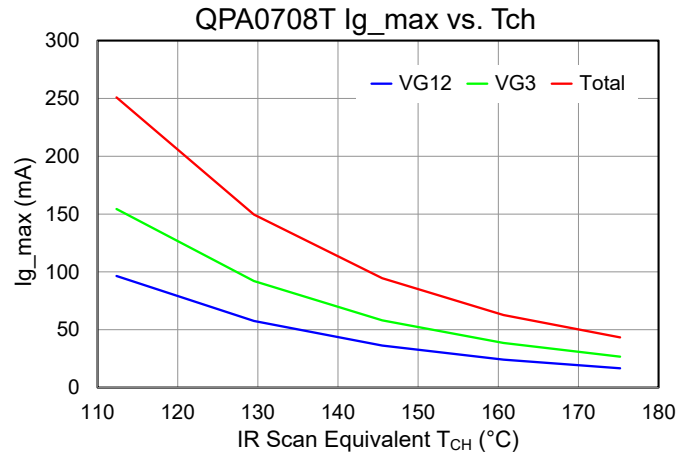
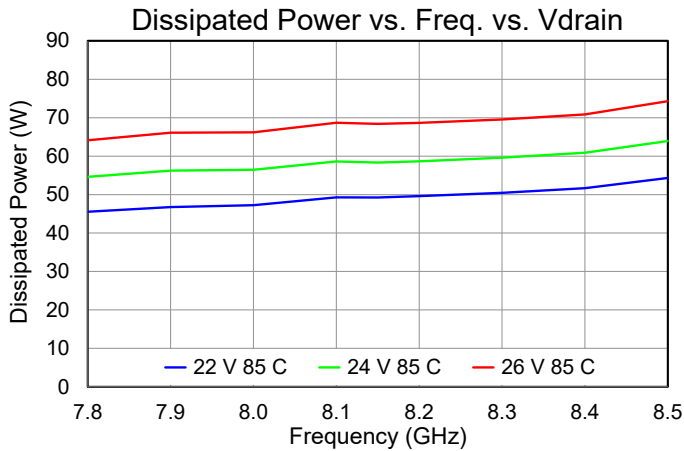

Test conditions, unless otherwise noted: V<sub>D</sub> = 26 V, I<sub>DQ</sub> = 904 mA, T<sub>+</sub> = +85 °C, P<sub>IN</sub> = 18 dBm  
 All performance data presented is for the bare die measured on the EVB

## Applications Information

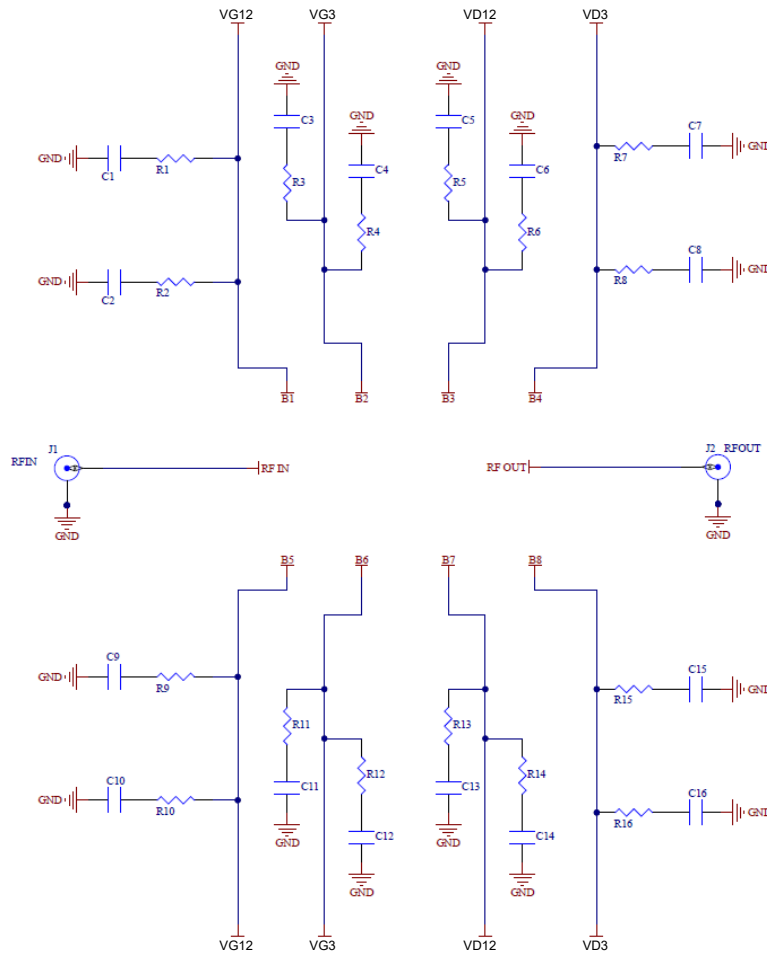

$V_{G\_TOP}$  and  $V_{G\_BOTTOM}$  should be tied together (apply bias from both sides)

$V_{D\_TOP}$  and  $V_{D\_BOTTOM}$  should be tied together (apply bias from both sides)

$V_{G12}$  and  $V_{G3}$  can be separated in a customer's system, if desired, in an attempt to improve IMD performance

### Bias-Up Procedure

1. Set  $I_D$  limit to 7500 mA,  $I_G$  limit to 40 mA
2. Set  $V_G$  to -4.0 V
3. Set  $V_D$  +26 V
4. Adjust  $V_G$  more positive until  $I_{DQ} \approx 904$  mA
5. Apply RF signal

### Bias-Down Procedure

1. Turn off RF signal
2. Reduce  $V_G$  to -4.0 V. Ensure  $I_{DQ} \sim 0$  mA
4. Set  $V_D$  to 0 V
5. Turn off  $V_D$  supply
6. Turn off  $V_G$  supply

Evaluation Board (EVB) Layout Assembly

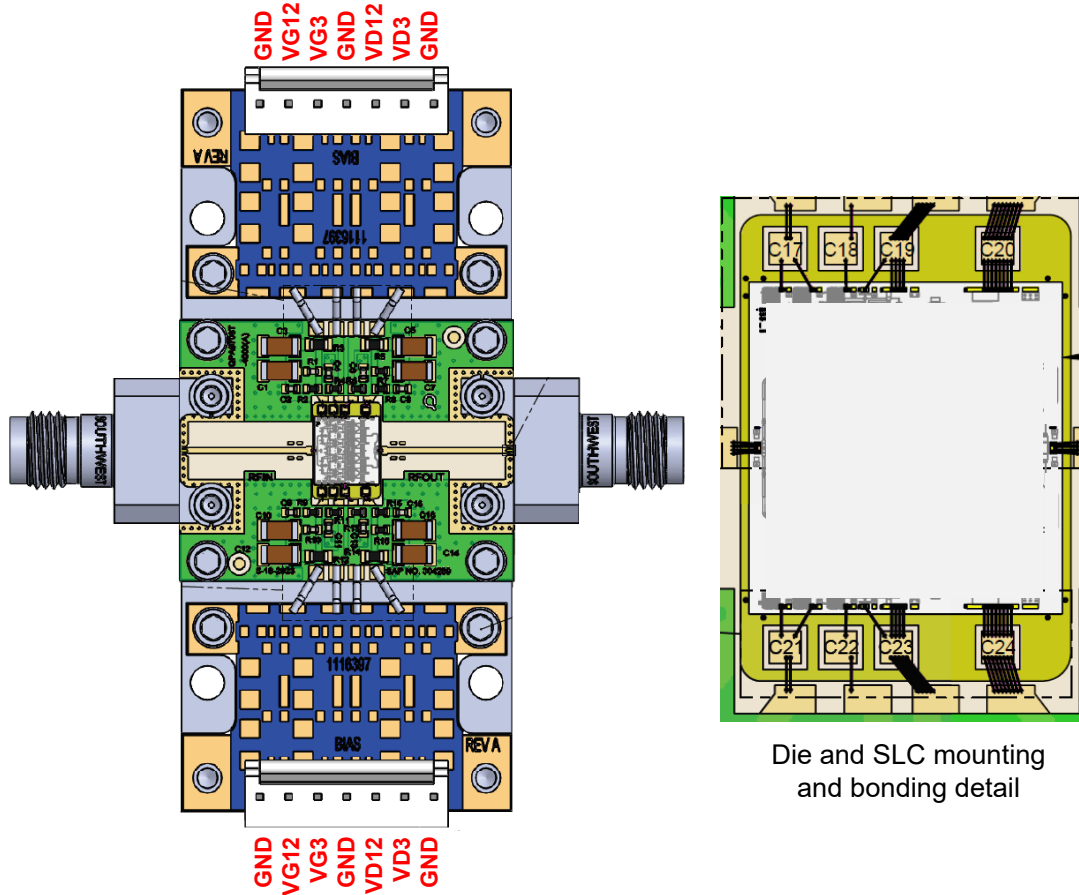

PCB is made from TACONICS RF-35HTC, 0.010 inch thick, 0.5 oz. copper both sides.  
Note: EVB shown is for the bare die; there is no EVB available for the QPA0708T.

Bill of Materials

Reference Des.	Value	Description	Manuf.	Part Number
C1,C3,C5,C7,C10,C12,C14,C16	10 uF	CAP, 10uF, 20%, 50V, 20%, X5R, 1206	Various	
C2,C4,C6,C8,C9,C11,C13,C15	0.01 uF	CAP, 0.01uF, 10%, 50V, X7R, 0402	Various	
C17,C18,C19,C20,C21,C22,C23,C24	10 nF	CAP, 10nF, 15%, 30V,0303,SL Si WFR NO UV	Various	
R2,R4,R6,R7,R8,R9,R11,R13,R15,R16	0 Ω	RES, 0 OHM, JMPR, 0402	Various	
R3,R5,R12,R14	5.1 Ω	RES, 5.1 OHM, 1%, 1/10W, 0603	Various	
R1,R10	5.1 Ω	RES, 5.1 OHM, 1%, 1/10W, 0402	Various	
J1, J2		RF Connector, SMA	Southwest Microwave	292-04A-5

Note: Schematic, EVB layout, and components based on the EVB for the bare die

## Mechanical Drawing and Bond Pad Description (MMIC Only)

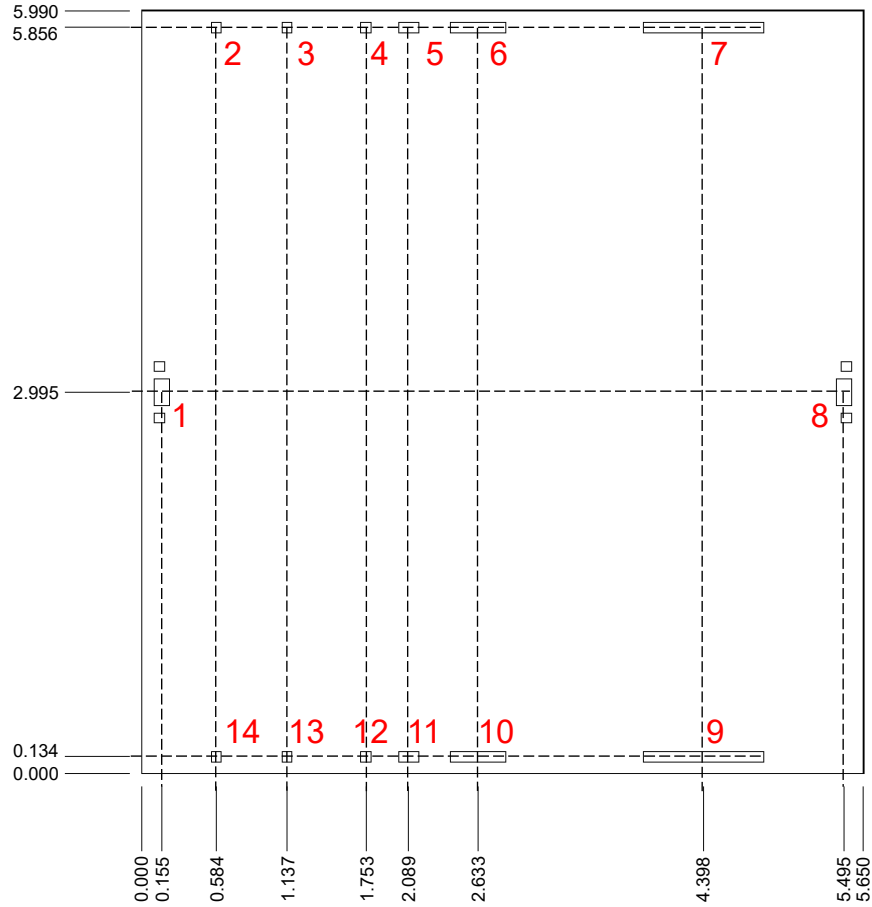

Dimensions are in mm  
Thickness: 0.100  
Die x, y size tolerance:  $\pm 0.050$   
Ground is backside of die

## Bond Pad Description

Pad No.	Symbol	Size ( $\mu\text{m} \times \mu\text{m}$ )	Description
1	RF IN	119 x 213	RF input. 50 Ohms. DC blocked; DC grounded.
2, 14	$V_{G1}$	77 x 77	Gate voltage stage 1. Bypass network required; refer to page 19.
3, 13	$V_{G2}$	77 x 77	Gate voltage stage 2. Bypass network required; refer to page 19.
4, 12	$V_{G3}$	77 x 77	Gate voltage stage 3. Bypass network required; refer to page 19.
5, 11	$V_{D1}$	152 x 77	Drain voltage stage 1. Bypass network required; refer to page 19.
6, 10	$V_{D2}$	432 x 77	Drain voltage stage 2. Bypass network required; refer to page 19.
7, 9	$V_{D3}$	942 x 77	Drain voltage stage 3. Bypass network required; refer to page 19.
8	RF OUT	119 x 213	RF output. 50 Ohms. DC blocked.

Mechanical Drawing (Die on Tab)

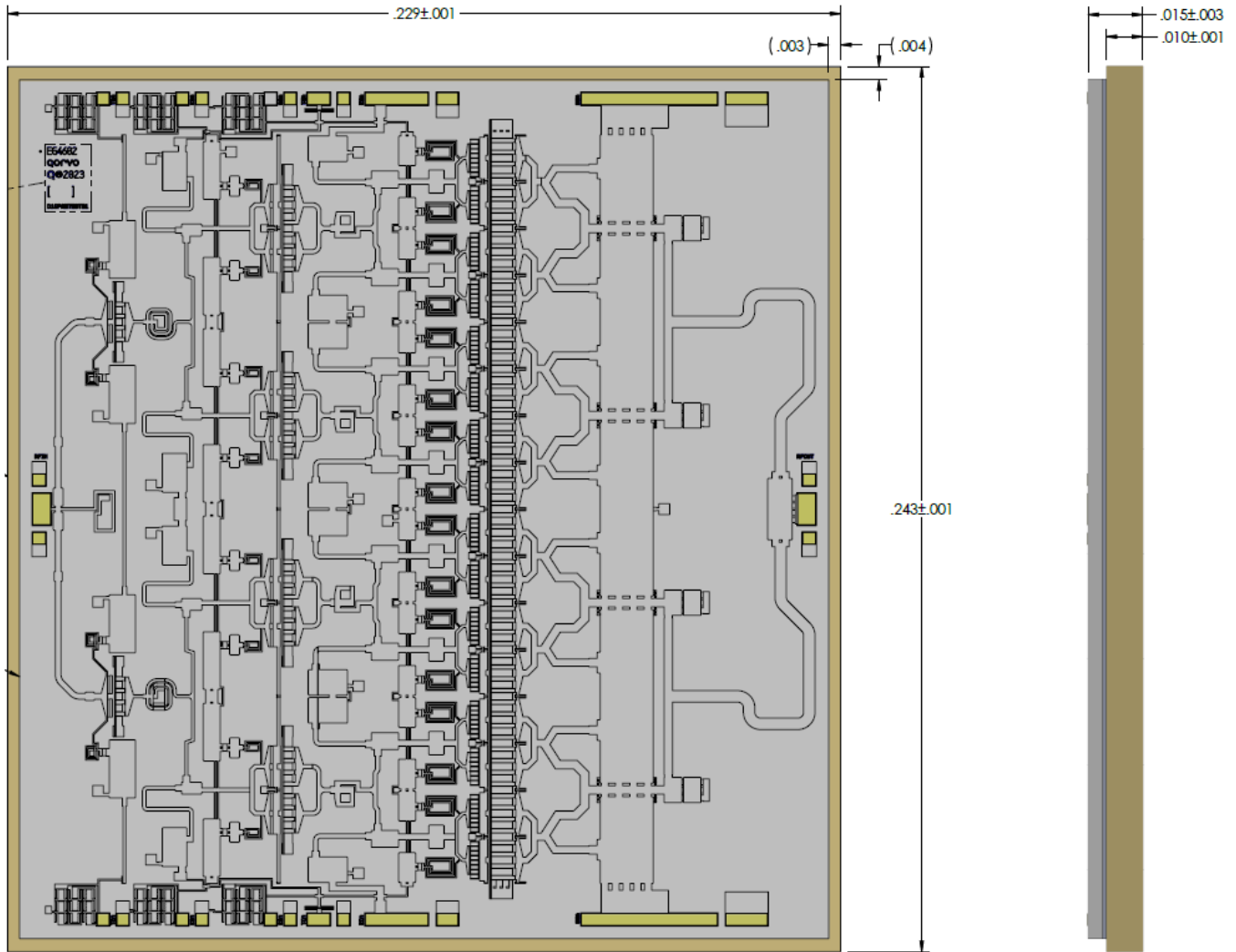

Notes:

1. Dimensions are in inches
2. Thermal spreader material: Cu-Mo
3. Plating: Gold

## Assembly Notes

---

Component placement and adhesive attachment assembly notes:

- Vacuum pencils and/or vacuum collets are the preferred method of pick up.
- Air bridges must be avoided during placement.
- The force impact is critical during auto placement.

Interconnect process assembly notes:

- Thermosonic ball bonding is the preferred interconnect technique.
- Force, time, and ultrasonic are critical parameters.
- Aluminum wire should not be used.
- Devices with small pad sizes should be bonded with 0.0007-inch wire.
- Maximum stage temperature is 200 °C.

## Handling Precautions

Parameter	Rating	Standard
ESD – Human Body Model (HBM)	Class 1A	ANSI/ESD/JEDEC JS-001



Caution!

ESD-Sensitive Device

## RoHS Compliance

This part is compliant with 2011/65/EU RoHS directive (Restrictions on the Use of Certain Hazardous Substances in Electrical and Electronic Equipment) as amended by Directive 2015/863/EU.

This product also has the following attributes:

- Lead Free
- Halogen Free (Chlorine, Bromine)
- Antimony Free
- TBBP-A (C<sub>15</sub>H<sub>12</sub>Br<sub>4</sub>O<sub>2</sub>) Free
- PFOS Free
- SVHC Free

## Contact Information

For the latest specifications, additional product information, worldwide sales and distribution locations:

**Web:** [www.qorvo.com](http://www.qorvo.com)

**Tel:** 1-844-890-8163

**Email:** [customer.support@qorvo.com](mailto:customer.support@qorvo.com)

## Important Notice

The information contained herein is believed to be reliable; however, Qorvo makes no warranties regarding the information contained herein and assumes no responsibility or liability whatsoever for the use of the information contained herein. All information contained herein is subject to change without notice. Customers should obtain and verify the latest relevant information before placing orders for Qorvo products. The information contained herein or any use of such information does not grant, explicitly or implicitly, to any party any patent rights, licenses, or any other intellectual property rights, whether with regard to such information itself or anything described by such information. **THIS INFORMATION DOES NOT CONSTITUTE A WARRANTY WITH RESPECT TO THE PRODUCTS DESCRIBED HEREIN, AND QORVO HEREBY DISCLAIMS ANY AND ALL WARRANTIES WITH RESPECT TO SUCH PRODUCTS WHETHER EXPRESS OR IMPLIED BY LAW, COURSE OF DEALING, COURSE OF PERFORMANCE, USAGE OF TRADE OR OTHERWISE, INCLUDING THE IMPLIED WARRANTIES OF MERCHANTABILITY AND FITNESS FOR A PARTICULAR PURPOSE.**

Without limiting the generality of the foregoing, Qorvo products are not warranted or authorized for use as critical components in medical, life-saving, or life-sustaining applications, or other applications where a failure would reasonably be expected to cause severe personal injury or death.

© 2025 Qorvo US, Inc. All rights reserved. This document is subject to copyright laws in various jurisdictions worldwide and may not be reproduced or distributed, in whole or in part, without the express written consent of Qorvo US, Inc.

## Looking for pricing, stock, or lifecycle information?

Click below to explore more details on WIN SOURCE:

 [View QPA0708T on WIN SOURCE](#)

 [Qorvo US Inc. Information](#)

## Optimize Your Supply Chain with WIN SOURCE Solutions

-  Global Sourcing Solution
-  Obsolete Management
-  Cost Control Management
-  Shortage Management
-  Alternative Solution
-  Excess Inventory Management