



Typical unit

FEATURES

- iLGA inspectable Land Grid Array
- 4.5-14Vdc input voltage range (W12) or 2.4-5.5Vdc input voltage range (W5)
- Settable output voltage from 0.591-5.5Vdc (W12) or from 0.6-3.63Vdc (W5)
- Drives up to 200 uF ceramic capacitive loads
- High power conversion efficiency at 93% (W12) or 95.3% (W5)
- Outstanding thermal derating performance
- Short circuit and over current protection
- On/Off control (W12 and W5) and Power Good signal (W12 only)
- Optional Sequence/Tracking operation (OKL2-T/3 models)
- Certified to UL/IEC 60950-1 safety, 2nd Edition
- RoHS hazardous substance compliance

PRODUCT OVERVIEW

The OKL-T/3-W12 and the OKL-T/3-W5 series are miniature non-isolated Point-of-Load (PoL) DC-DC power converters for embedded applications. Featuring inspectable Land Grid Array (iLGA) format, the OKL-T/3 measures only 0.48 x 0.48 x 0.244 inches max. (12.2 x 12.2 x 6.2 mm max.).

The input range is 4.5 to 14 Volts DC for the OKL-T/3-W12 and 2.4 to 5.5V for the OKL-T/3-W5. The maximum output current is 3 Amps. Based on fixed-frequency synchronous buck converter switching topology, the high-power conversion efficient Point of Load (PoL) module features settable output voltage and On/Off control.

These converters also include undervoltage lockout (UVLO), output short circuit protection, and over-current protections.

An optional sequence/tracking feature on OKL2-T/3 models allows power sequencing of PoL's. These units are certified to all standard UL/ IEC 60950-1 safety certifications (2nd Edition) and RoHS hazardous substance compliance.

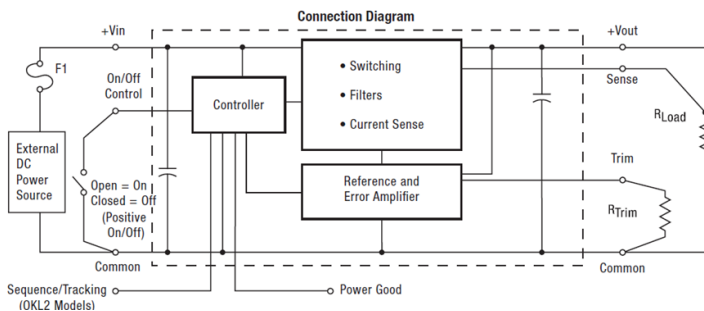

a) OKL-T/3-W12

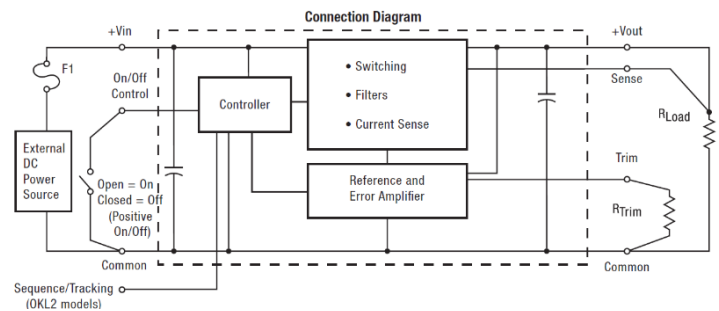

b) OKL-T/3-W5

Figure 1. Connection diagram

Note: Murata Power Solutions strongly recommends an external input fuse, F1. See specifications.



For full details go to
www.murata-ps.com/rohs



Performance Specifications and Ordering Guide

PERFORMANCE SPECIFICATIONS SUMMARY AND ORDERING GUIDE

Model Number	Output				Regulation (max.)		Input				Efficiency (%)		On/Off Logic	Seq/Track	Dimensions
	Vout (Volts) (1)	Iout (Amps, max.)	Power (Watts)	R/N (mV p-p) Max. (4)	Line	Load	Vin nom. (Volts)	Range (Volts)	Iin, no load (mA) (4)	Iin, full load (Amps) (2)	Min.	Typ.			Inches (mm)
OKL-T/3-W12P-C	0.591-5.5	3	15	37	±0.25%	±0.25%	12	4.5-14	20	1.34	91.0	93.0	Positive	no	0.48 x 0.48 x 0.244 (12.2 x 12.2 x 6.2)
OKL-T/3-W12N-C	0.591-5.5	3	15	37	±0.25%	±0.25%	12	4.5-14	20	1.34	91.0	93.0	Negative	no	0.48 x 0.48 x 0.244 (12.2 x 12.2 x 6.2)
OKL2-T/3-W12P-C	0.591-5.5	3	15	37	±0.25%	±0.25%	12	4.5-14	20	1.34	91.0	93.0	Positive	yes	0.48 x 0.48 x 0.244 (12.2 x 12.2 x 6.2)
OKL2-T/3-W12N-C	0.591-5.5	3	15	37	±0.25%	±0.25%	12	4.5-14	20	1.34	91.0	93.0	Negative	yes	0.48 x 0.48 x 0.244 (12.2 x 12.2 x 6.2)
OKL-T/3-W5P-C	0.6-3.63	3	9.9	25	±0.25%	±0.25%	5	2.4-5.5	25	2.08	93.3	95.3	Positive	no	0.48 x 0.48 x 0.244 (12.2 x 12.2 x 6.2)
OKL-T/3-W5N-C	0.6-3.63	3	9.9	25	±0.25%	±0.25%	5	2.4-5.5	25	2.08	93.3	95.3	Negative	no	0.48 x 0.48 x 0.244 (12.2 x 12.2 x 6.2)
OKL2-T/3-W5P-C	0.6-3.63	3	9.9	25	±0.25%	±0.25%	5	2.4-5.5	25	2.08	93.3	95.3	Positive	yes	0.48 x 0.48 x 0.244 (12.2 x 12.2 x 6.2)
OKL2-T/3-W5N-C	0.6-3.63	3	9.9	25	±0.25%	±0.25%	5	2.4-5.5	25	2.08	93.3	95.3	Negative	yes	0.48 x 0.48 x 0.244 (12.2 x 12.2 x 6.2)

- (1) The output range is limited by Vin. See detailed specs.
- (2) All specifications are at nominal line voltage, Vout = nominal (5V for W12 or 3.3V for W5) and full load, 25 degC. unless otherwise noted. Output capacitors are 10 uF ceramic. Input cap is 22 uF. I/O capacitors are necessary for our test equipment and may not be needed for your application.
- (3) Use adequate ground plane and copper thickness adjacent to the converter.
- (4) Ripple and Noise (R/N) and no-load input current are shown at Vout = 1V.

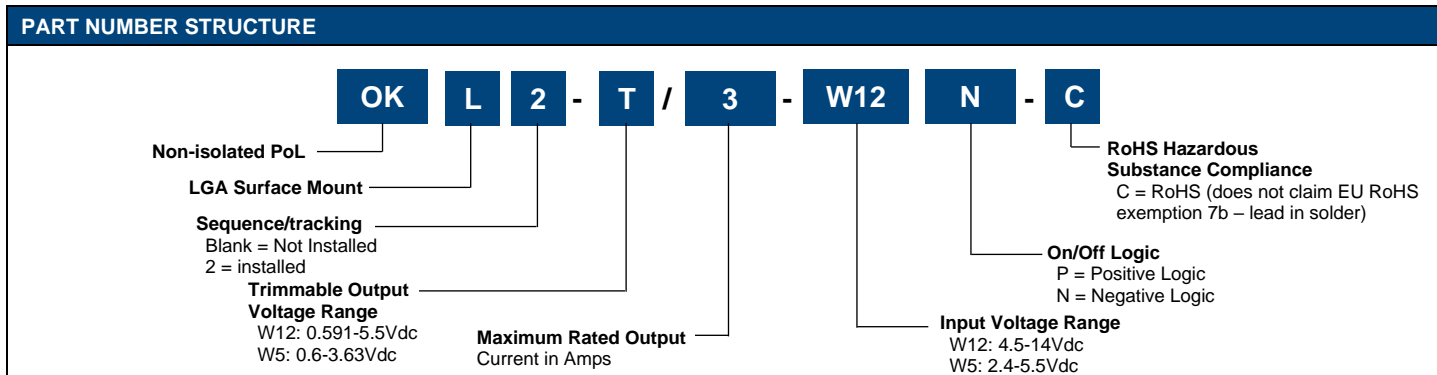

Product Label

Because of the small size of these products, the product label contains a character-reduced code to indicate the model number and manufacturing date code. Not all items on the label are always used. Please note that the label differs from the product photograph. Here is the layout of the label:

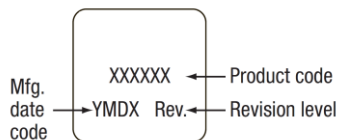

Figure 2. Label Artwork Layout

The label contains two rows of information:

- First row – Model number product code (see table)
- Second row – Manufacturing date code and revision level

Model Number	Product Code
OKL-T/3-W12P-C	L01103
OKL-T/3-W12N-C	L00103
OKL2-T/3-W12P-C	L21103
OKL2-T/3-W12N-C	L20103
OKL-T/3-W5P-C	L01003
OKL-T/3-W5N-C	L00003
OKL2-T/3-W5P-C	L21003
OKL2-T/3-W5N-C	L20003

The manufacturing date code is four characters:

- First character – Last digit of manufacturing year, example 2009
- Second character – Month code (1 through 9 = Jan-Sep.; X, Y, Z = Oct, Nov, Dec)
- Third character – Day code (1 through 9 = 1 to 9, 10 = 0 and 11 through 31 = A through Z)
- Fourth character – Manufacturing information

FUNCTIONAL SPECIFICATIONS

ABSOLUTE MAXIMUM RATINGS	Conditions (1)	Minimum	Typical/Nominal	Maximum	Units	
Input Voltage, Continuous	Continuous or transient	OKL-T/3-W12	0		15	Vdc
		OKL-T/3-W5	0		6	Vdc
Output Power	OKL-T/3-W12			16.5	W	
	OKL-T/3-W5			10.1	W	
Output Current	Current-limited, no damage, short-circuit protected	0		3	A	
On/Off Control		0		Vin	Vdc	
Power Good Pin	OKL-T/3-W12 only			5	Vdc	
Sequence Pin				Vin	Vdc	

Absolute maximums are stress ratings. Exposure of devices to greater than any of these conditions may adversely affect long-term reliability. Proper operation under conditions other than those listed in the Performance/Functional Specifications Table is not implied or recommended.

INPUT

Operating voltage range (7)	See output voltage vs input voltage	OKL-T/3-W12	4.5	12	14	Vdc
		OKL-T/3-W5	2.4	5	5.5	Vdc
Reverse Polarity Protection				None		
Recommended External Fuse	Fast blow				4	A
Turn On/Start-up threshold	Rising input voltage	OKL-T/3-W12	-	4.2	-	Vdc
		OKL-T/3-W5	-	2.05	-	Vdc
Undervoltage Shutdown (15)		OKL-T/3-W12	-	3.4	-	Vdc
		OKL-T/3-W5	-	1.92	-	Vdc
Overvoltage Shutdown				None		
Internal Filter Type				Capacitive		
Input current						
Full Load Conditions	Vin = 12V, 5Vout, Iout = 3A	OKL-T/3-W12		1.34		A
	Vin = 5V, 3.3Vout, Iout = 3A	OKL-T/3-W5		2.08		A
Low Line	Vin = 6.2V, 5Vout, Iout = 3A	OKL-T/3-W12		2.24		A
No Load Input Current	Vin = 12V, 1Vout, No load	OKL-T/3-W12		20		mA
		OKL-T/3-W5		25		mA
Shut-Down Mode Input Current				1		mA
Output in Short Circuit	OKL-T/3-W12			5		mA
	OKL-T/3-W5			10		mA

GENERAL and SAFETY

Efficiency	OKL-T/3-W12 Vin = 12V, Iout = 3A	5Vout	91	93		%
		3.3Vout		91.5		%
		2.5Vout		90		%
		1.8Vout		88		%
		1Vout		82		%
		0.591Vout		74		%
	OKL-T/3-W5 Vin = 5V, Iout = 3A	3.3Vout	93.3	95.3		%
		2.5Vout		93.8		%
		1.8Vout		91.7		%
		1.2Vout		88.8		%
				87		%
				80.8		%
Safety			Certified to UL-60950-1, CSA-C22.2 No.60950-1, IEC/60950-1, 2nd edition			
Calculated MTBF (4a)	Telcordia SR332, issue 1 class 3, ground fixed, Tambient = 25 degC	OKL-T/3-W12		10,011,000		Hours
		OKL2-T/3-W12		9,227,000		Hours
		OKL-T/3-W5		10,820,000		Hours
		OKL2-T/3-W5		5,229,000		Hours
Calculated MTBF (4b)	MIL-HDBK-217N2 Method	OKL-T/3-W12		4,448,000		Hours
		OKL2-T/3-W12		4,392,000		Hours
		OKL-T/3-W5		4,820,000		Hours
		OKL2-T/3-W5		3,832,000		Hours

DYNAMIC CHARACTERISTICS

Fixed Switching Frequency				600		KHz
Startup Time	Power ON to Vout regulated			6		mS
Startup Time	Remote ON to Vout regulated	3		4	6	mS
Dynamic Load Response (1)	50-100-50% load step, settling time to within $\pm 2\%$ of Vout di/dt = 1A/uSec	OKL-T/3-W12			200	uSec
		OKL-T/3-W5			50	uSec
Dynamic Load Peak Deviation	same as above			± 250		mV

FEATURES and OPTIONS	Conditions (1)	Minimum	Typical/Nominal	Maximum	Units	
Remote On/Off Control (5)						
"N" suffix						
Negative Logic, ON state	OKL-T/3-W12	-0.2	Open	0.3	V	
	OKL-T/3-W5	-0.2		Vin-1.6	V	
Negative Logic, OFF state	OKL-T/3-W12	3.5	Open	Vin	V	
	OKL-T/3-W5	Vin-0.8		Vin	V	
Control Current	See Figure 9					
"P" suffix						
Positive Logic, ON state	OKL-T/3-W12	3.5	Open	Vin	V	
	OKL-T/3-W5	1.2		Vin	V	
Positive Logic, OFF state	OKL-T/3-W12	-0.3	Open	0.4	V	
	OKL-T/3-W5	-0.3		0.3	V	
Control Current	See Figure 8					
Tracking/Sequencing(optional) (16)						
Slew Rate			2		V/ms	
Tracking Accuracy	Rising input (0.5V/ms)		±100		mV	
Tracking Accuracy	Falling input (0.5V/ms)		±100		mV	
Power Good Option						
PGOOD, Open Drain Configuration, Sinking (OKL-T/3-W12 only)						
Vout window for PGOOD: True		-10%		10%	Vset	
Vout window for PGOOD: False		0		0.4	Vdc	
Sink current				10	mA	
OUTPUT						
Total Output Power	OKL-T/3-W12	0	15	16.5	W	
	OKL-T/3-W5	0	9.9	10.1	W	
Voltage						
Nominal Output Voltage Range (13)	See trim formula	OKL-T/3-W12	0.591	5.5	Vdc	
		OKL-T/3-W5	0.6	3.63	Vdc	
Setting Accuracy	At 50% load	OKL-T/3-W12	-1.5	1.5	% of Vnom.	
		OKL-T/3-W5	-2.5	2.5	% of Vnom.	
Overvoltage Protection (16)			None			
Current						
Output Current Range		0		3	A	
Minimum Load			No minimum load			
Current Limit Inception (6)	98% of Vnom., after warmup	OKL-T/3-W12		6	A	
		OKL-T/3-W5		8	A	
Short Circuit						
Short Circuit Current (17)	Hiccup auto recovery upon overload removal		0.01		A	
Short Circuit Duration (remove short for recovery)	Output shorted to ground, no damage		Continuous			
Short circuit protection method			Current limiting			
Prebias Startup		Converter will start up if the external output voltage is less than Vnominal.				
Regulation (10)						
Total Regulation Band	Include line and load range Rtrim = 0.5% tolerance	OKL-T/3-W12	-2.5	Vo set	2.5	% Vo set
		OKL-T/3-W5	-3.0	Vo set	3.0	% Vo set
Line Regulation	Vin = min. to max. Vout = nom.			±0.25	%	
Load Regulation	Iout = min. to max.			±0.25	%	
Ripple and Noise (8)	Vin = 12V, 1Vout, BW = 20MHz	OKL-T/3-W12		37	mV pk-pk	
	Vin = 12V, 5Vout, BW = 20MHz			60	mV pk-pk	
	Vin = 5V, 1Vout, BW = 20MHz	OKL-T/3-W5		25	mV pk-pk	
Temperature Coefficient	At all outputs		±0.02% per degC of Vnom.			
Maximum Capacitive Loading (14)	Low ESR = 0.001 to 0.01 ohms	0		200	uF	

FUNCTIONAL SPECIFICATIONS (CONT.)

MECHANICAL	Conditions (1)	Minimum	Typical/Nominal	Maximum	Units
Outline Dimensions			0.48 x 0.48 x 0.244		inches
			12.2 x 12.2 x 6.2		mm
Weight			0.06		ounces
			1.6		grams
ENVIRONMENTAL					
Operating Ambient Temperature Range (9)	full power, all output voltages, see derating curves	-40		85	degC
Storage Temperature Range	Vin = Zero (no power)	-55		125	degC
Operating Humidity Range		20		85	%
Maximum Wet Bulb Temperature				39	degC
RoHS rating			RoHS		

Specification Notes:

- (1) Specifications are typical at 25 degC, Vin = nominal (+12V for W12 or +5V for W5), Vout = nominal (+5V for W12 or +3.3V for W5), full load, external caps and natural convection unless otherwise indicated. Extended tests at full power must supply substantial forced airflow. All models are tested and specified with external 10uF ceramic output capacitors and a 22 uF external input capacitor. All capacitors are low ESR types. These capacitors are necessary to accommodate our test equipment and may not be required to achieve specified performance in your applications. However, Murata Power Solutions recommends installation of these capacitors. All models are stable and regulate within spec under no-load conditions.
- (2) Input Back Ripple Current is tested and specified over a 5 Hz to 20 MHz bandwidth. Input filtering is Cin = 2 x 100 uF ceramic, Cbus = 1000 uF electrolytic, Lbus = 1 uH.
- (3) Note that Maximum Power Derating curves indicate an average current at nominal input voltage. At higher temperatures and/or lower airflow, the DC-DC converter will tolerate brief full current outputs if the total RMS current over time does not exceed the Derating curve.
- (4a) Mean Time Before Failure is calculated using the Telcordia (Belcore) SR-332 Method 1, Case 3, ground fixed conditions, Tpcbboard = 25 degC, full output load, natural air convection.
- (4b) Mean Time Before Failure is calculated using the MIL-HDBK-217N2 method, ground benign, 25 degC., full output load, natural convection.
- (5) The On/Off Control Input should use either a switch or an open collector/open drain transistor referenced to -Input Common. A logic gate may also be used by applying appropriate external voltages which do not exceed +Vin.
- (6) Short circuit shutdown begins when the output voltage degrades approximately 2% from the selected setting.
- (7) Please observe the voltage input and output specifications in the Voltage Range Graph.
- (8) Output noise may be further reduced by adding an external filter. At zero output current, the output may contain low frequency components which exceed the ripple specification. The output may be operated indefinitely with no load.
- (9) All models are fully operational and meet published specifications, including "cold start" at -40 degC.
- (10) Regulation specifications describe the deviation as the line input voltage or output load current is varied from a nominal midpoint value to either extreme.
- (11) Other input or output voltage ranges will be reviewed under scheduled quantity special order.
- (12) Maximum PC board temperature is measured with the sensor in the center of the converter.
- (13) Do not exceed maximum power specifications when adjusting the output trim.
- (14) The maximum output capacitive loads depend on the Equivalent Series Resistance (ESR) of the external output capacitor and, to a lesser extent, the distance and series impedance to the load. Larger caps will reduce output noise but may change the transient response. Newer ceramic caps with very low ESR may require lower capacitor values to avoid instability. Thoroughly test your capacitors in the application. Please refer to the Output Capacitive Load Application Note.
- (15) Do not allow the input voltage to degrade lower than the input undervoltage shutdown voltage at all times. Otherwise, you risk having the converter turn off. The undervoltage shutdown is not latching and will attempt to recover when the input is brought back into normal operating range.
- (16) The outputs are not intended to sink appreciable reverse current.
- (17) "Hiccup" overcurrent operation repeatedly attempts to restart the converter with a brief, full-current output. If the overcurrent condition still exists, the restart current will be removed and then tried again. This short current pulse prevents overheating and damaging the converter. Once the fault is removed, the converter immediately recovers normal operation.

OKL-T/3-W12 PERFORMANCE DATA AND OSCILLOGRAMS

Efficiency vs. Line Voltage and Load Current @25 degC
(Vout = 5V)

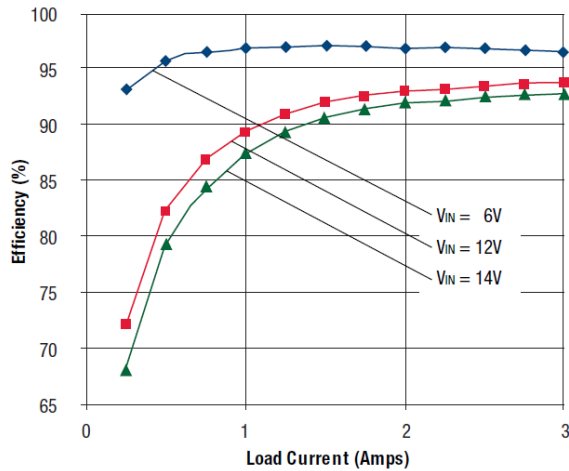

Maximum Current Temperature Derating at Sea Level
(Vin = 12V, Vout = 5V)

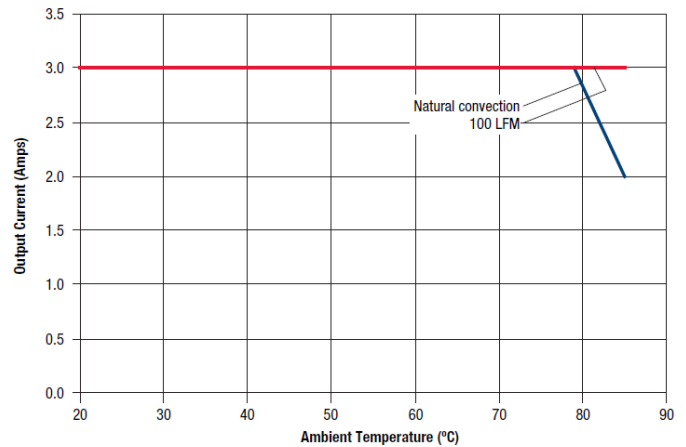

On/Off Enable Startup Delay (Vin = 12V, Vout = 5.0V, Iout = 3A, Cload = 0)
Trace 4 = Enable In, Trace2 = Vout

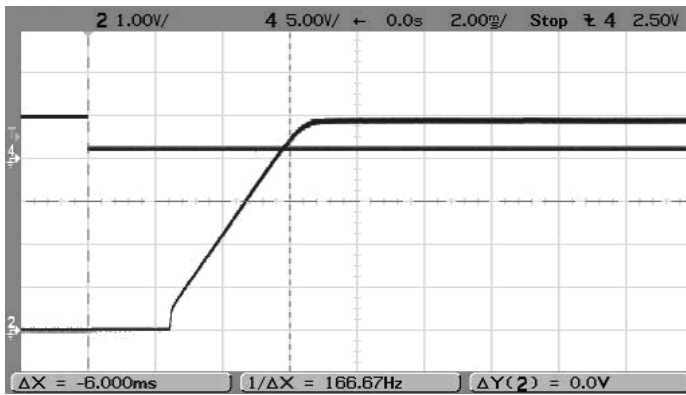

Output Ripple and Noise (Vin = 12V, Vout = 5.0V, Iout = 3A, Cload = 0, ScopeBW = 20MHz)

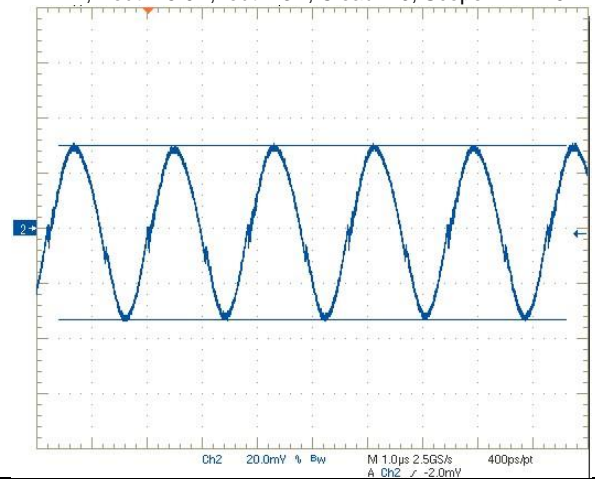

Step Load Transient Response (Vin = 12V, Vout = 5.0V, Cload = 0, Iout = 1.5 to 3A)
Trace 2 = Vout, 100 mV/div. Trace 4 = Iout, 2.5A/div.

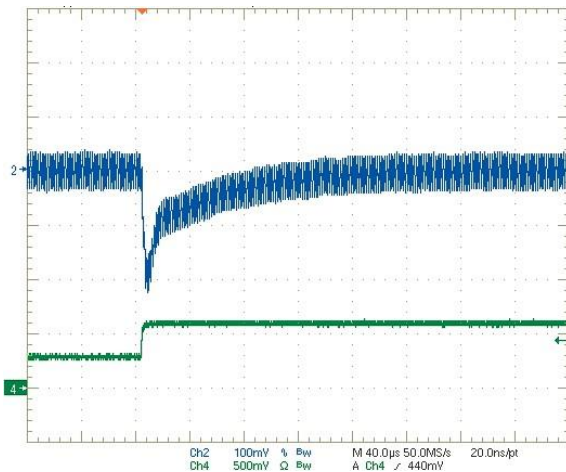

Step Load Transient Response (Vin = 12V, Vout = 5.0V, Cload = 0, Iout = 3 to 1.5A)
Trace 2 = Vout, 100 mV/div. Trace 4 = Iout, 2.5A/div.

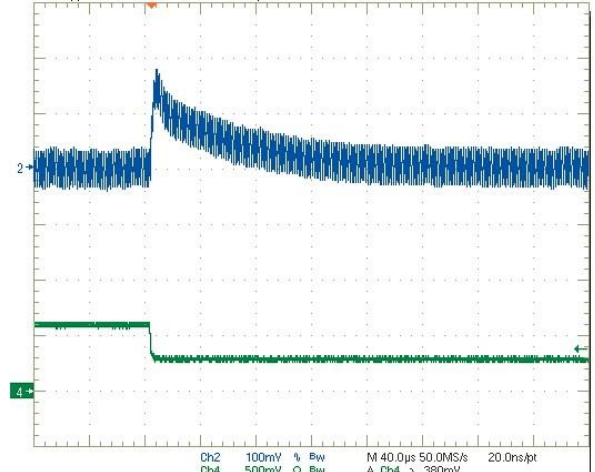

OKL-T/3-W12 PERFORMANCE DATA AND OSCILLOGRAMS

Efficiency vs. Line Voltage and Load Current @25 degC
(Vout = 3.3V)

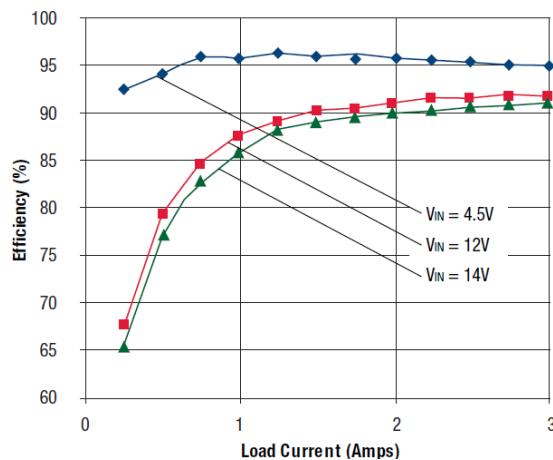

Maximum Current Temperature Derating at Sea Level
(Vin = 12V, Vout = 3.3V)

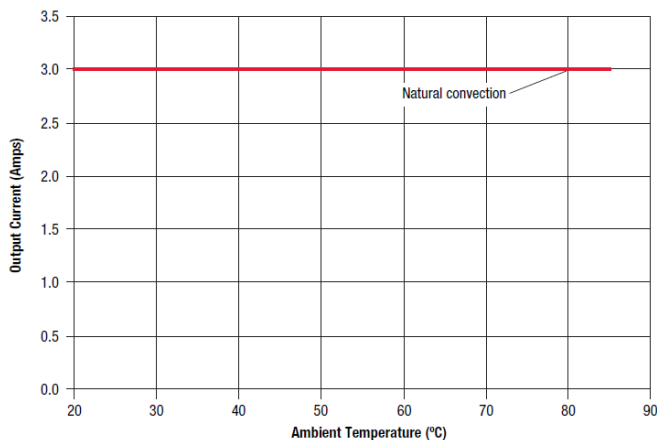

On/Off Enable Startup Delay (Vin = 12V, Vout = 3.3V, Iout = 3A, Cloud = 0)
Trace 4 = Enable In, Trace2 = Vout

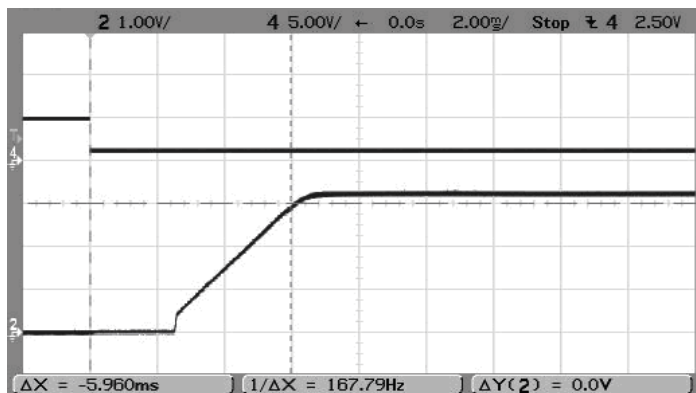

Output Ripple and Noise (Vin = 12V, Vout = 3.3V, Iout = 3A, Cloud = 0, ScopeBW = 20MHz)

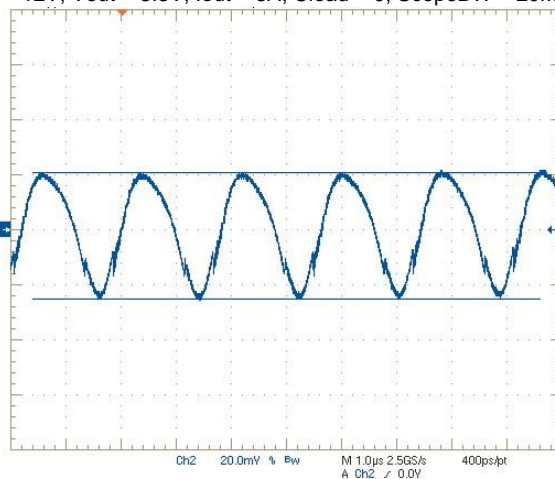

Step Load Transient Response (Vin = 12V, Vout = 3.3V, Cloud = 0, Iout = 1.5 to 3A)
Trace 2 = Vout, 100 mV/div. Trace 4 = Iout, 2.5A/div.

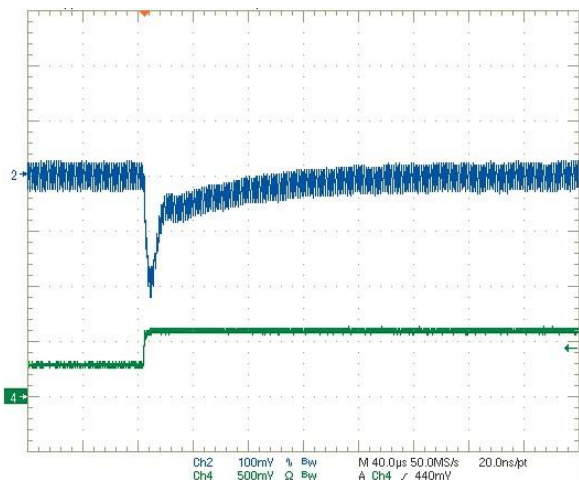

Step Load Transient Response (Vin = 12V, Vout = 3.3V, Cloud = 0, Iout = 3 to 1.5A)
Trace 2 = Vout, 100 mV/div. Trace 4 = Iout, 2.5A/div.

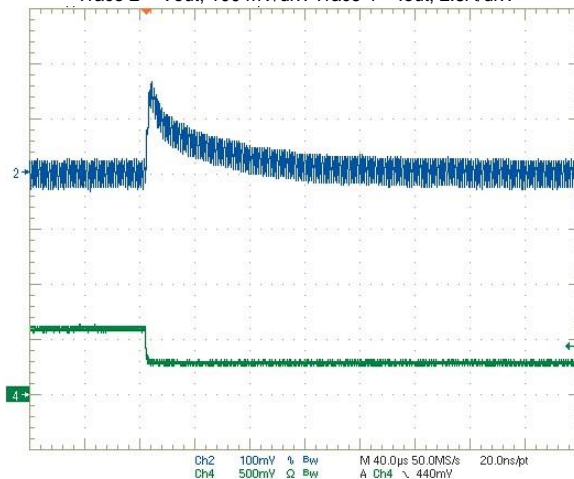

OKL-T/3-W12 PERFORMANCE DATA AND OSCILLOGRAMS

Efficiency vs. Line Voltage and Load Current @25 degC
(Vout = 2.5V)

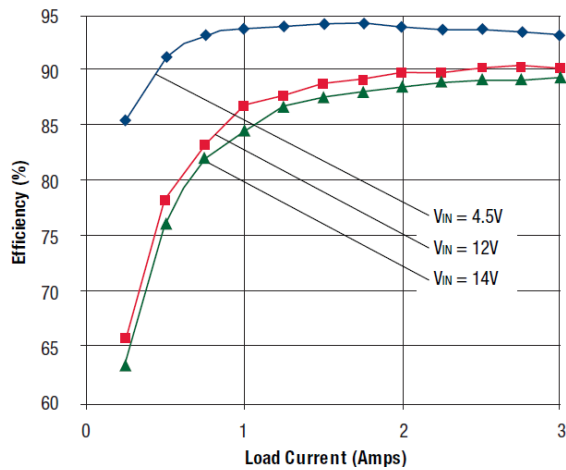

Maximum Current Temperature Derating at Sea Level
(Vin = 12V, Vout = 2.5V)

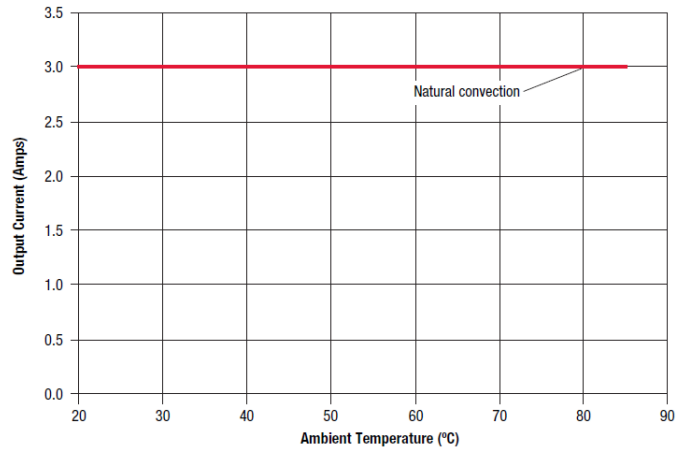

On/Off Enable Startup Delay (Vin = 12V, Vout = 2.5V, Iout = 3A, Cload = 0)
Trace 4 = Enable In, Trace2 = Vout

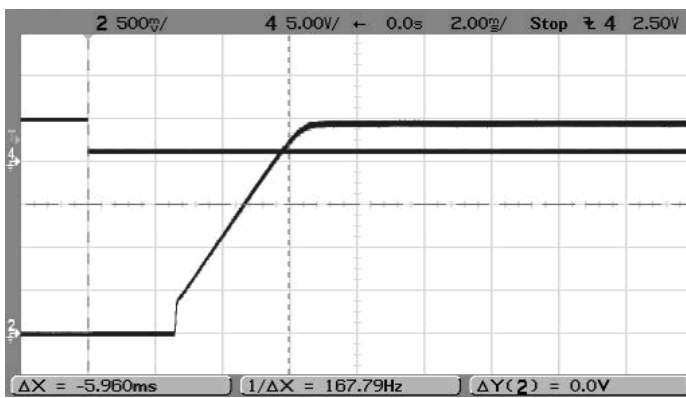

Output Ripple and Noise (Vin = 12V, Vout = 2.5V, Iout = 3A, Cload = 0, ScopeBW = 20MHz)

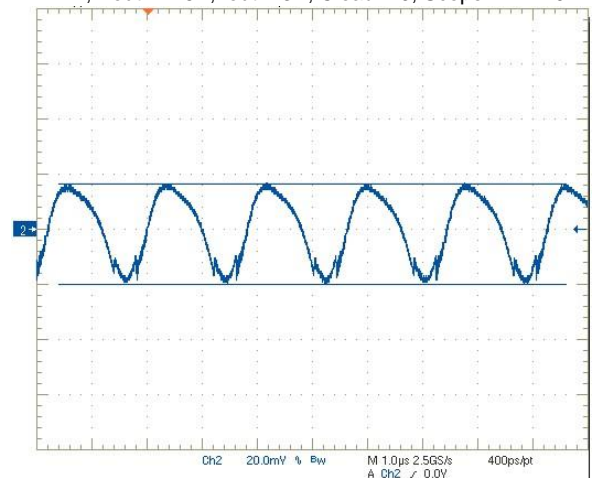

Step Load Transient Response (Vin = 12V, Vout = 2.5V, Cload = 0, Iout = 1.5 to 3A)
Trace 2 = Vout, 100 mV/div. Trace 4 = Iout, 2.5A/div.

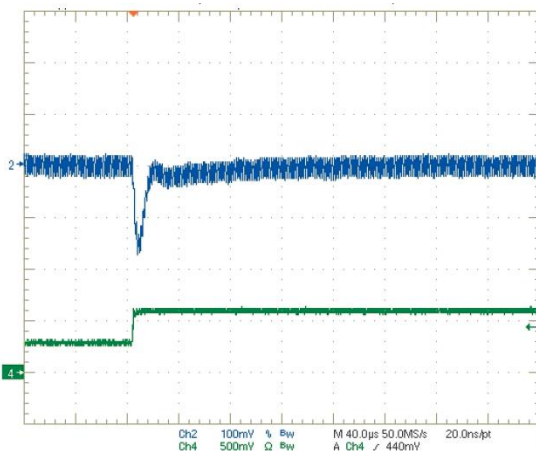

Step Load Transient Response (Vin = 12V, Vout = 2.5V, Cload = 0, Iout = 3 to 1.5A)
Trace 2 = Vout, 100 mV/div. Trace 4 = Iout, 2.5A/div.

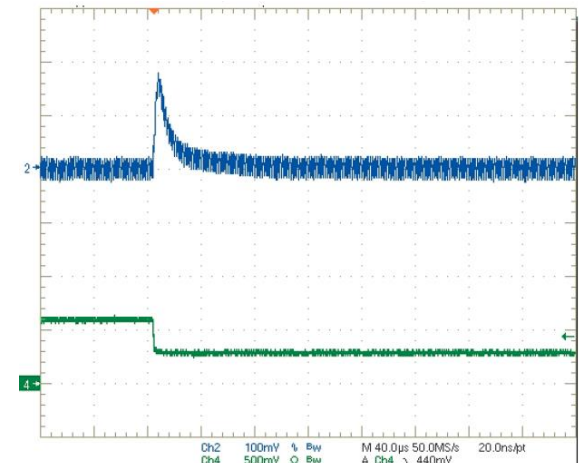

OKL-T/3-W12 PERFORMANCE DATA AND OSCILLOGRAMS

Output Ripple and Noise
($V_{in} = 12V$, $V_{out} = 1.8V$, $I_{out} = 3A$, $C_{load} = 0$, ScopeBW = 20MHz)

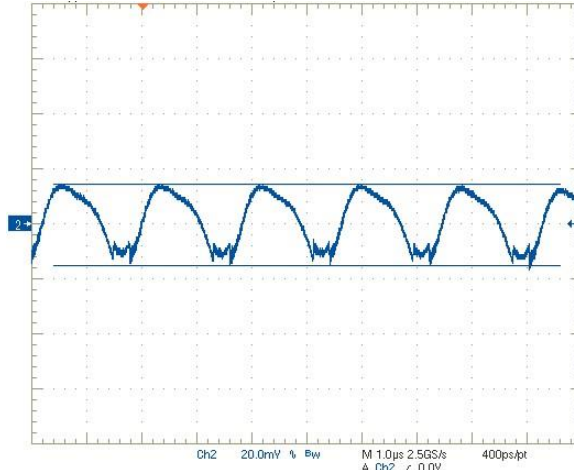

Step Load Transient Response ($V_{in} = 12V$, $V_{out} = 1.8V$, $C_{load} = 0$, $I_{out} = 1.5$ to $3A$)
Trace 2 = V_{out} , 100 mV/div. Trace 4 = I_{out} , 2.5A/div.

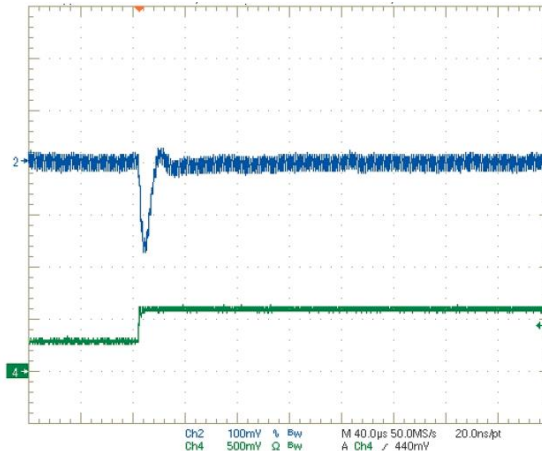

Step Load Transient Response ($V_{in} = 12V$, $V_{out} = 1.8V$, $C_{load} = 0$, $I_{out} = 3$ to $1.5A$)
Trace 2 = V_{out} , 100 mV/div. Trace 4 = I_{out} , 2.5A/div.

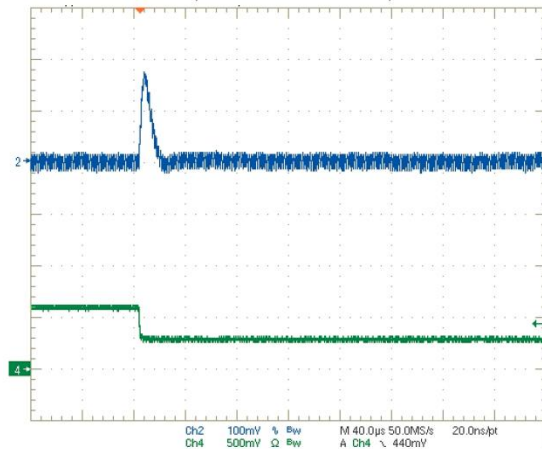

OKL-T/3-W12 PERFORMANCE DATA AND OSCILLOGRAMS

Efficiency vs. Line Voltage and Load Current @25 degC
(Vout = 1.2V)

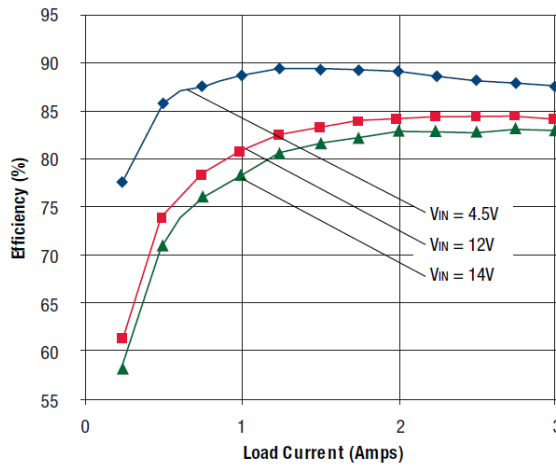

Maximum Current Temperature Derating at Sea Level
(Vin = 12V, Vout = 1.2V)

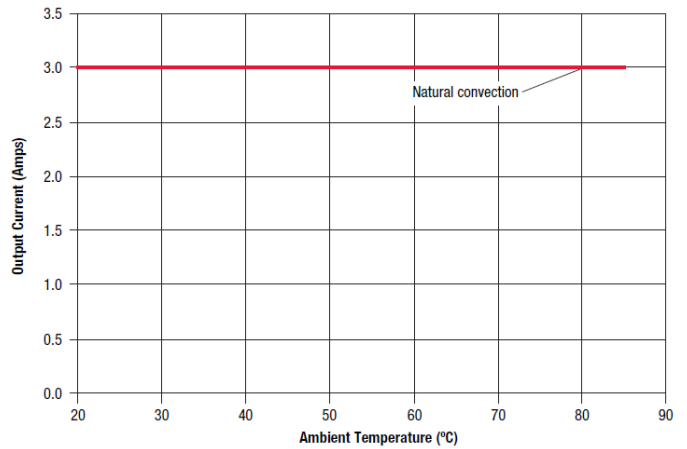

On/Off Enable Startup Delay (Vin = 12V, Vout = 1.2V, Iout = 3A, Clod = 0)
Trace 4 = Enable In, Trace2 = Vout

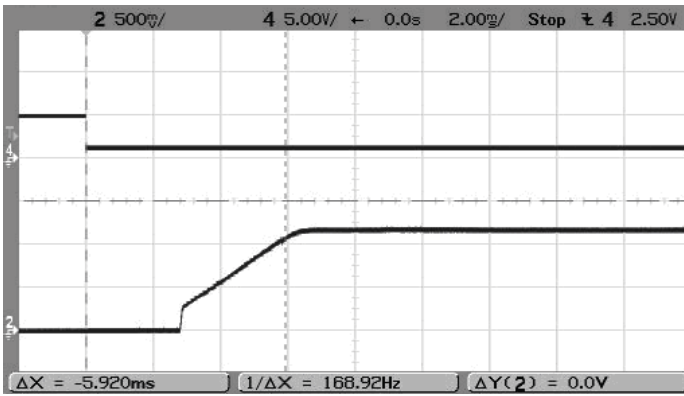

Output Ripple and Noise
(Vin = 12V, Vout = 1.2V, Iout = 3A, Clod = 0, ScopeBW = 20MHz)



Step Load Transient Response (Vin = 12V, Vout = 1.2V, Clod = 0, Iout = 1.5 to 3A)
Trace 2 = Vout, 100 mV/div. Trace 4 = Iout, 2.5A/div.

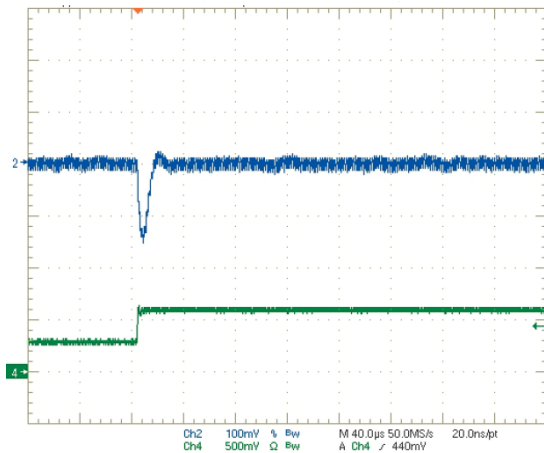

Step Load Transient Response (Vin = 12V, Vout = 1.2V, Clod = 0, Iout = 3 to 1.5A)
Trace 2 = Vout, 100 mV/div. Trace 4 = Iout, 2.5A/div.

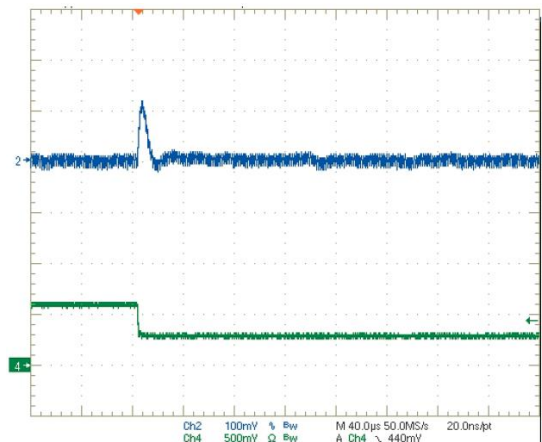

OKL-T/3-W12 PERFORMANCE DATA AND OSCILLOGRAMS

Output Ripple and Noise
($V_{in} = 12V$, $V_{out} = 1.0V$, $I_{out} = 3A$, $C_{load} = 0$, ScopeBW = 20MHz)

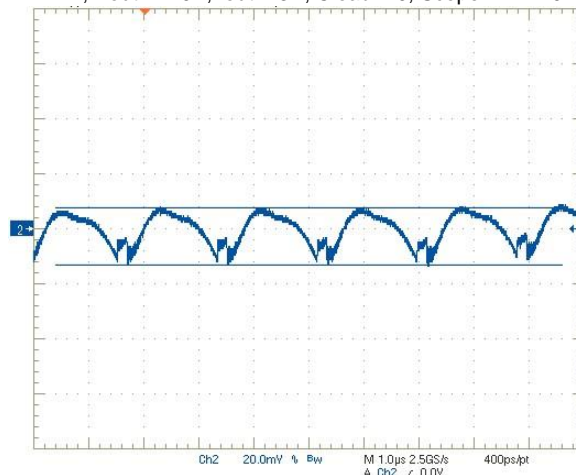

Step Load Transient Response ($V_{in} = 12V$, $V_{out} = 1.0V$, $C_{load} = 0$, $I_{out} = 1.5$ to $3A$)
Trace 2 = V_{out} , 100 mV/div. Trace 4 = I_{out} , 2.5A/div.

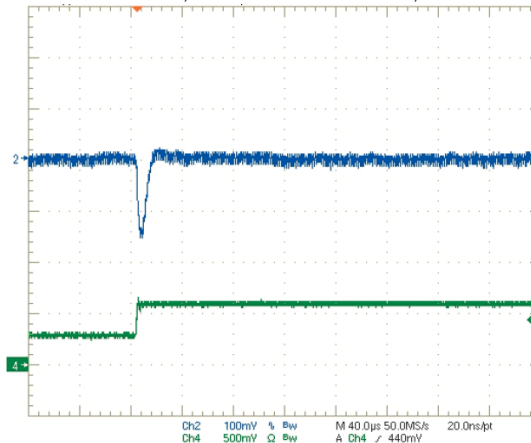

Step Load Transient Response ($V_{in} = 12V$, $V_{out} = 1.0V$, $C_{load} = 0$, $I_{out} = 3$ to $1.5A$)
Trace 2 = V_{out} , 100 mV/div. Trace 4 = I_{out} , 2.5A/div.

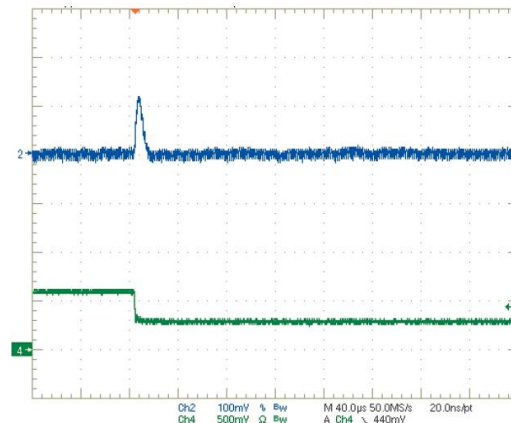

OKL-T/3-W5 PERFORMANCE DATA AND OSCILLOGRAMS

Efficiency vs. Line Voltage and Load Current @25 degC
(Vout = 3.3V)

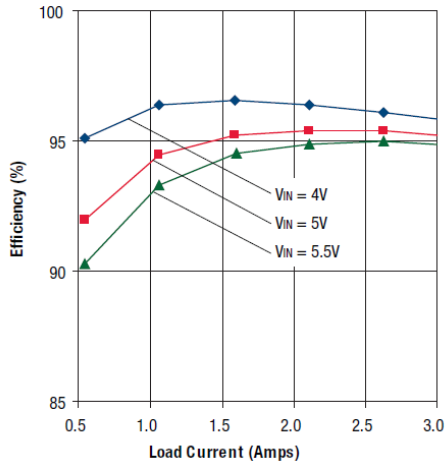

Maximum Current Temperature Derating at Sea Level
(Vin = 5V, Vout = 3.3V)

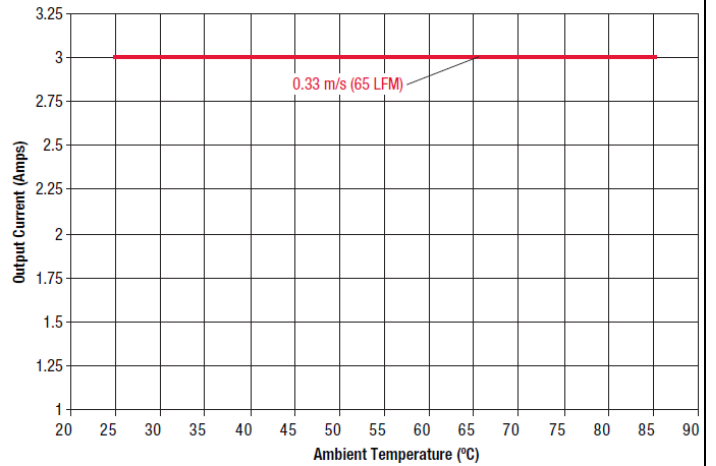

On/Off Enable Startup Delay (Vin = 5V, Vout = 3.3V, Iout = 3A, Clload = 0)
Trace 4 = Enable In, Trace2 = Vout

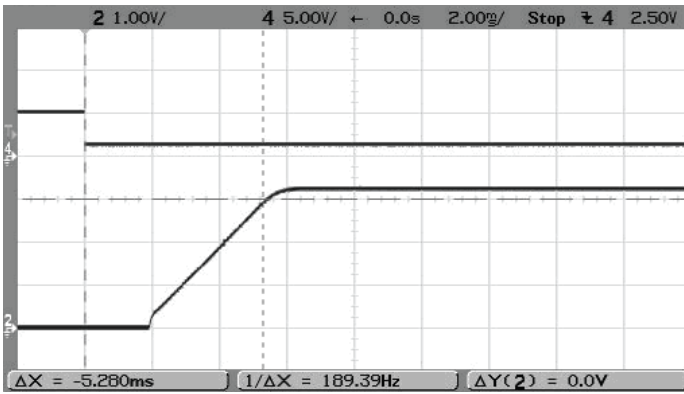

Output Ripple and Noise (Vin = 5V, Vout = 3.3V, Iout = 3A, Clload = 0, ScopeBW = 20MHz)

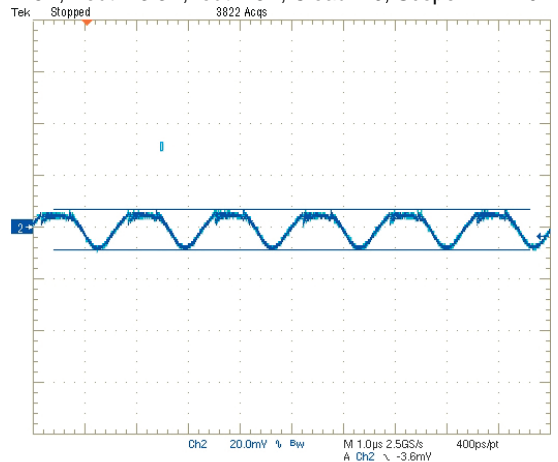

Step Load Transient Response (Vin = 5V, Vout = 3.3V, Clload = 0, Iout = 1.5 to 3A)
Trace 2 = Vout, 100 mV/div. Trace 4 = Iout, 2.5A/div.

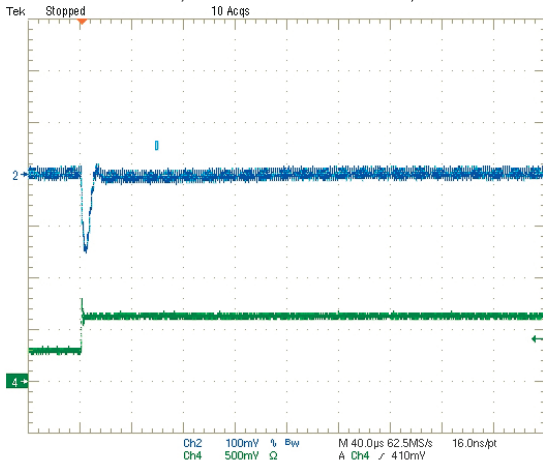

Step Load Transient Response (Vin = 5V, Vout = 3.3V, Clload = 0, Iout = 3 to 1.5A)
Trace 2 = Vout, 100 mV/div. Trace 4 = Iout, 2.5A/div.

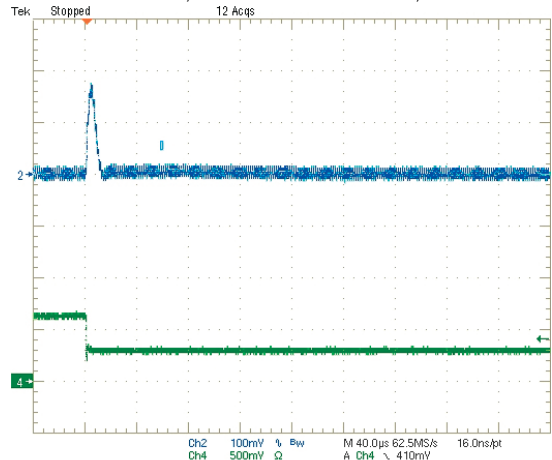

OKL-T/3-W5 PERFORMANCE DATA AND OSCILLOGRAMS

Efficiency vs. Line Voltage and Load Current @25 degC
(Vout = 2.5V)

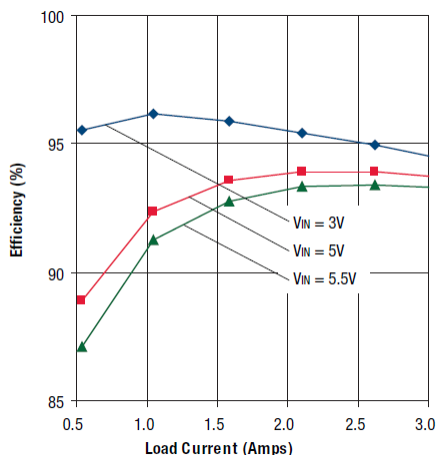

Maximum Current Temperature Derating at Sea Level
(Vin = 5V, Vout = 2.5V)

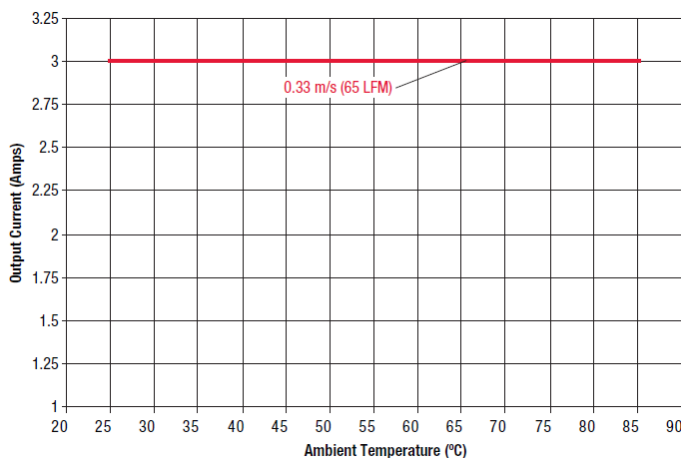

On/Off Enable Startup Delay (Vin = 5V, Vout = 2.5V, Iout = 3A, Clload = 0)
Trace 4 = Enable In, Trace2 = Vout

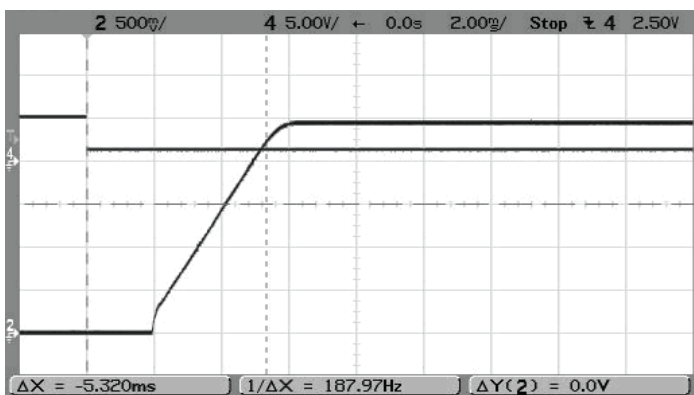

Output Ripple and Noise (Vin = 5V, Vout = 2.5V, Iout = 3A, Clload = 0, ScopeBW = 20MHz)

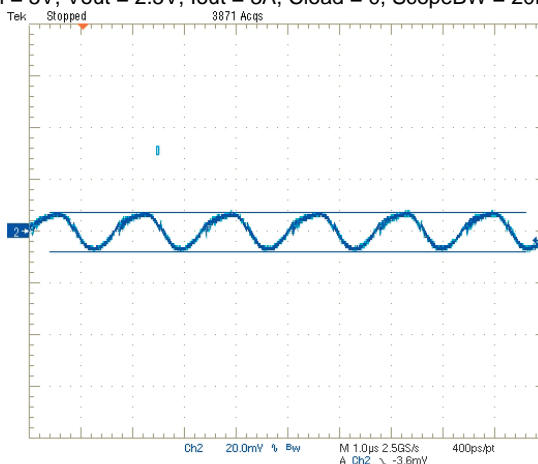

Step Load Transient Response (Vin = 5V, Vout = 2.5V, Clload = 0, Iout = 1.5 to 3A)
Trace 2 = Vout, 100 mV/div. Trace 4 = Iout, 2.5A/div.

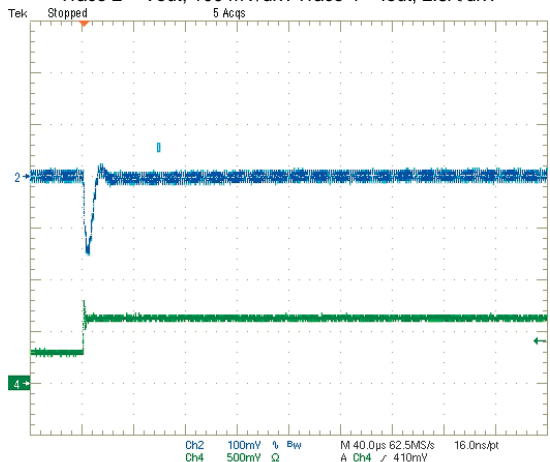

Step Load Transient Response (Vin = 5V, Vout = 2.5V, Clload = 0, Iout = 3 to 1.5A)
Trace 2 = Vout, 100 mV/div. Trace 4 = Iout, 2.5A/div.

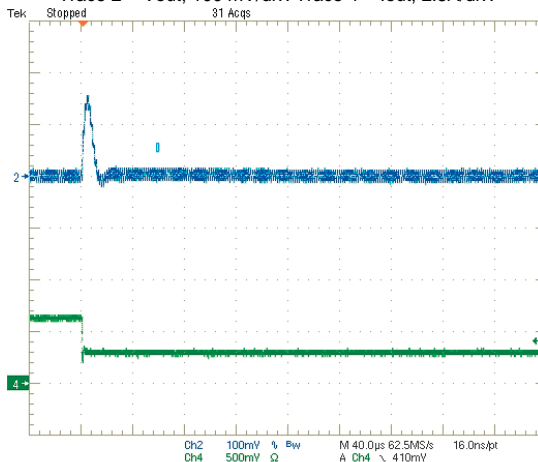

OKL-T/3-W5 PERFORMANCE DATA AND OSCILLOGRAMS

Efficiency vs. Line Voltage and Load Current @25 degC
(Vout = 1.8V)

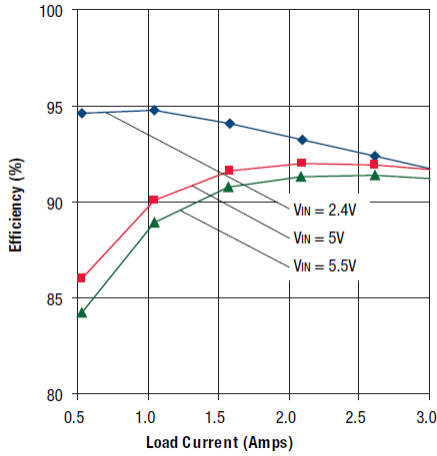

Maximum Current Temperature Derating at Sea Level
(Vin = 5V, Vout = 1.8V)

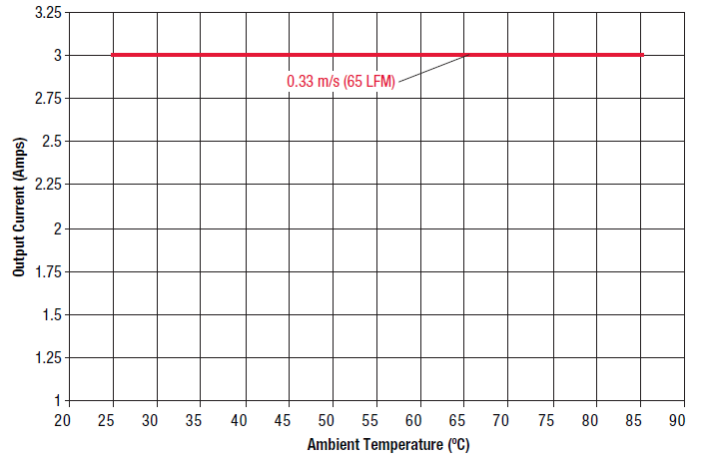

On/Off Enable Startup Delay (Vin = 5V, Vout = 1.8V, Iout = 3A, Clload = 0)
Trace 4 = Enable In, Trace2 = Vout

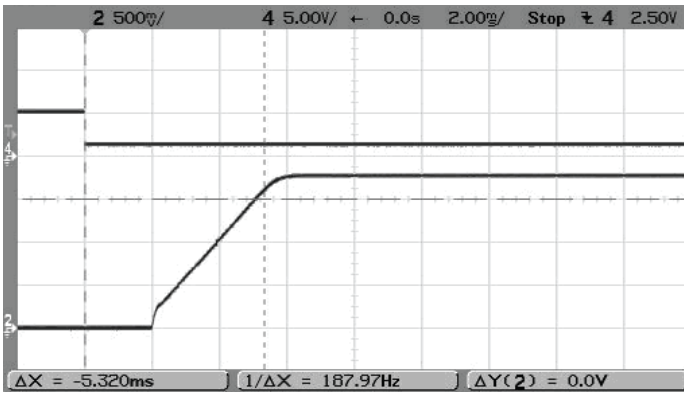

Output Ripple and Noise (Vin = 5V, Vout = 1.8V, Iout = 3A, Clload = 0, ScopeBW = 20MHz)

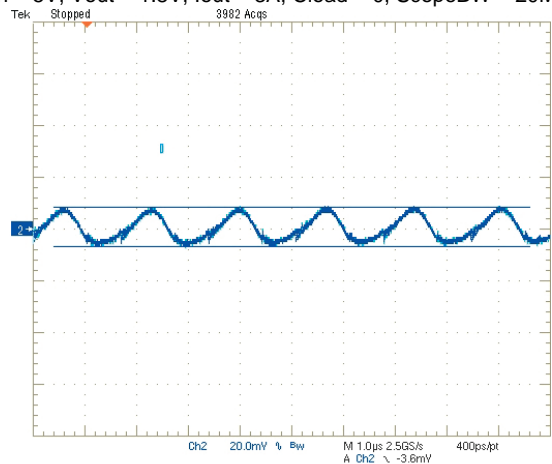

Step Load Transient Response (Vin = 5V, Vout = 1.8V, Clload = 0, Iout = 1.5 to 3A)
Trace 2 = Vout, 100 mV/div. Trace 4 = Iout, 2.5A/div.

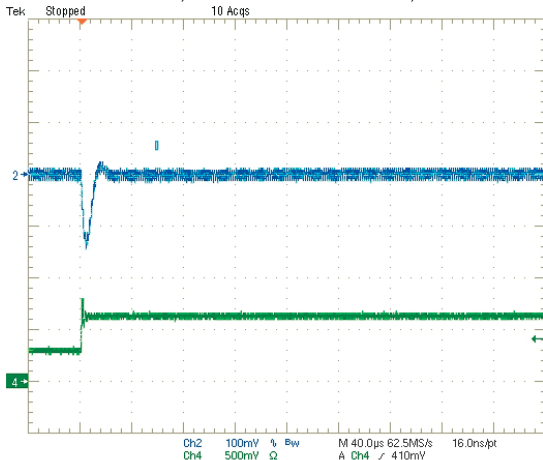

Step Load Transient Response (Vin = 5V, Vout = 1.8V, Clload = 0, Iout = 3 to 1.5A)
Trace 2 = Vout, 100 mV/div. Trace 4 = Iout, 2.5A/div.

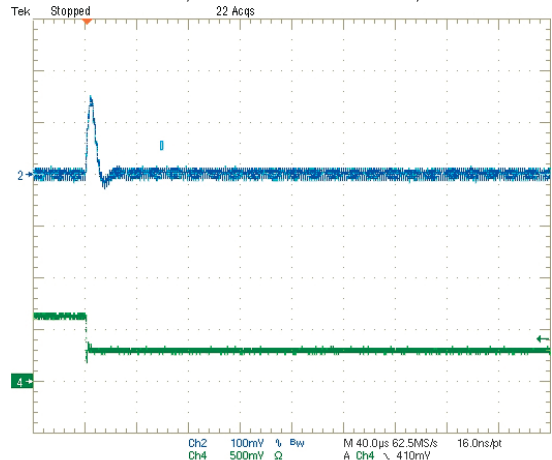

OKL-T/3-W5 PERFORMANCE DATA AND OSCILLOGRAMS

Efficiency vs. Line Voltage and Load Current @25 degC
(Vout = 1.5V)

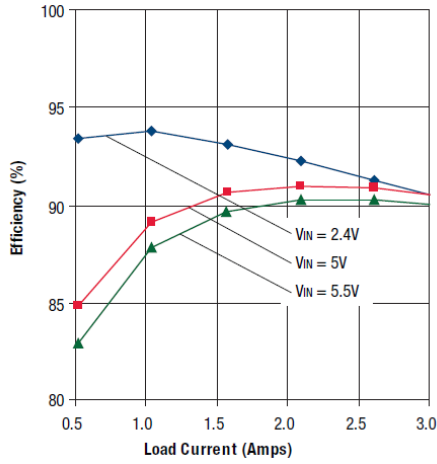

Maximum Current Temperature Derating at Sea Level
(Vin = 5V, Vout = 1.5V)

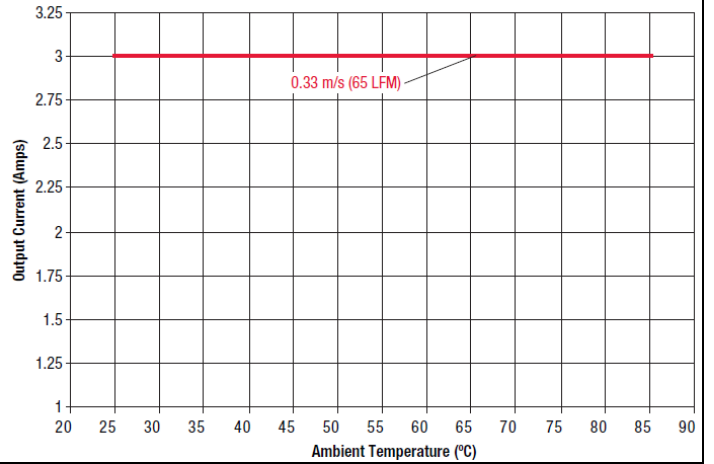

On/Off Enable Startup Delay (Vin = 5V, Vout = 1.5V, Iout = 3A, Clload = 0)
Trace 4 = Enable In, Trace2 = Vout

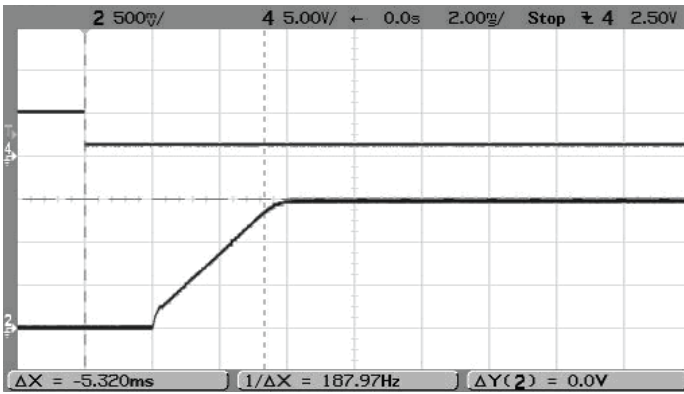

Output Ripple and Noise (Vin = 5V, Vout = 1.5V, Iout = 3A, Clload = 0, ScopeBW = 20MHz)

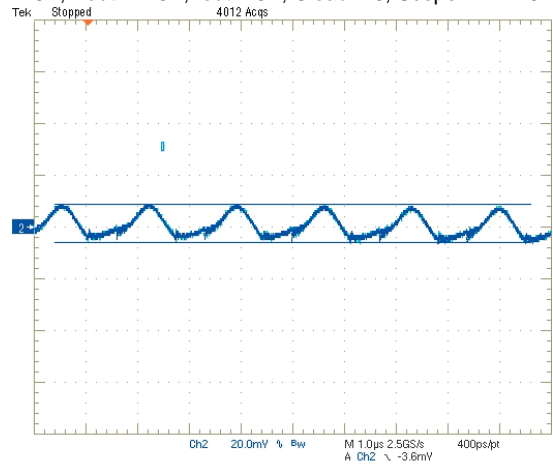

Step Load Transient Response (Vin = 5V, Vout = 1.5V, Clload = 0, Iout = 1.5 to 3A)
Trace 2 = Vout, 100 mV/div. Trace 4 = Iout, 2.5A/div.

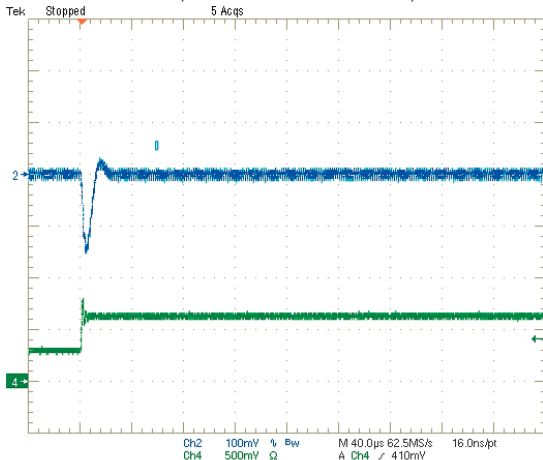

Step Load Transient Response (Vin = 5V, Vout = 1.5V, Clload = 0, Iout = 3 to 1.5A)
Trace 2 = Vout, 100 mV/div. Trace 4 = Iout, 2.5A/div.

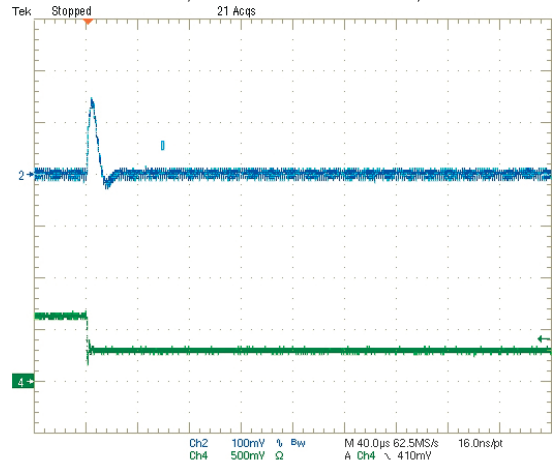

OKL-T/3-W5 PERFORMANCE DATA AND OSCILLOGRAMS

Efficiency vs. Line Voltage and Load Current @25 degC
(Vout = 1.2V)

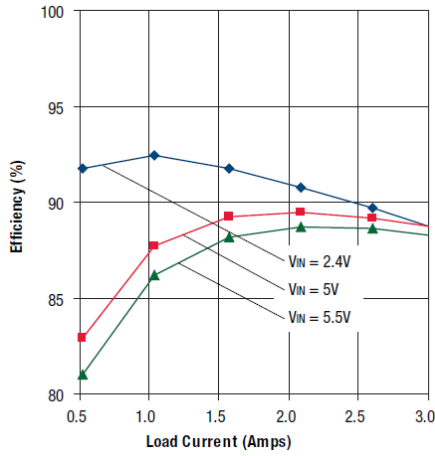

Maximum Current Temperature Derating at Sea Level
(Vin = 5V, Vout = 1.2V)

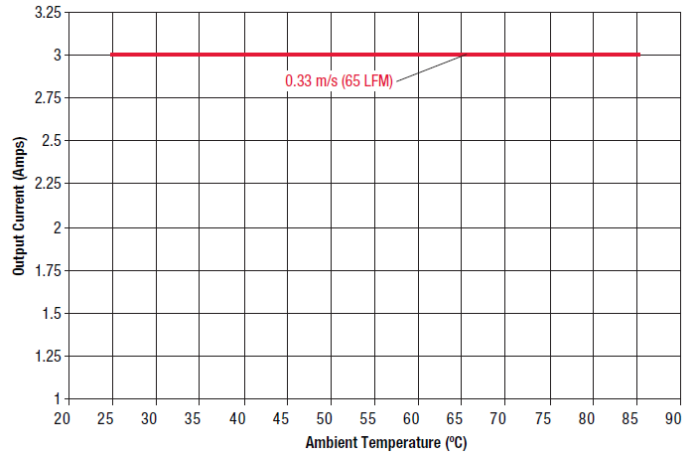

On/Off Enable Startup Delay (Vin = 5V, Vout = 1.2V, Iout = 3A, Clload = 0)
Trace 4 = Enable In, Trace2 = Vout

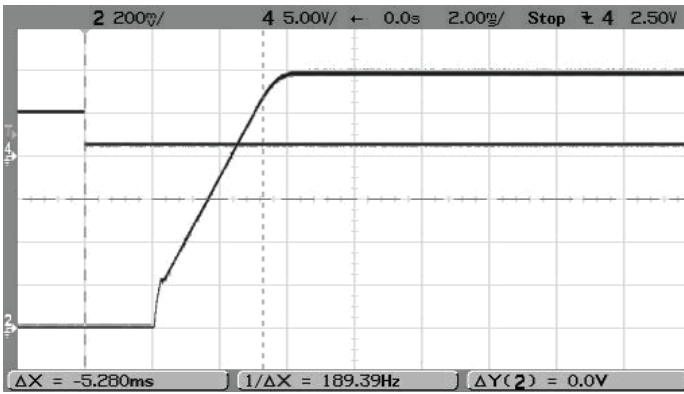

Output Ripple and Noise (Vin = 5V, Vout = 1.2V, Iout = 3A, Clload = 0, ScopeBW = 20MHz)

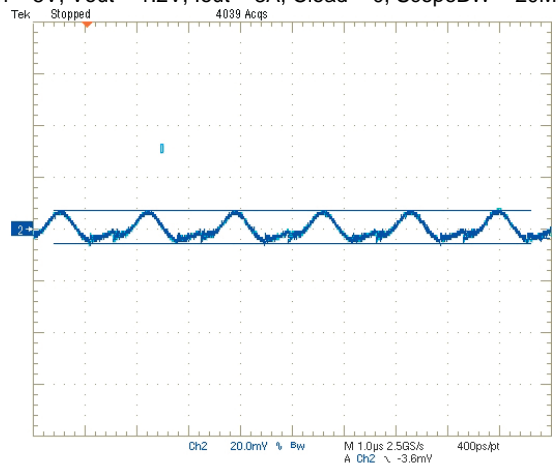

Step Load Transient Response (Vin = 5V, Vout = 1.2V, Clload = 0, Iout = 1.5 to 3A)
Trace 2 = Vout, 100 mV/div. Trace 4 = Iout, 2.5A/div.

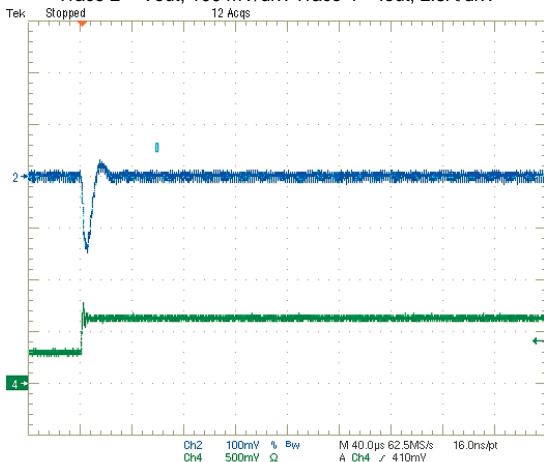

Step Load Transient Response (Vin = 5V, Vout = 1.2V, Clload = 0, Iout = 3 to 1.5A)
Trace 2 = Vout, 100 mV/div. Trace 4 = Iout, 2.5A/div.

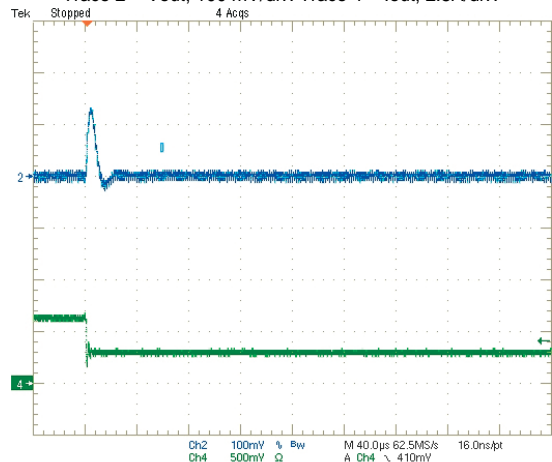

OKL-T/3-W5 PERFORMANCE DATA AND OSCILLOGRAMS

Efficiency vs. Line Voltage and Load Current @25 degC
(Vout = 1.0V)

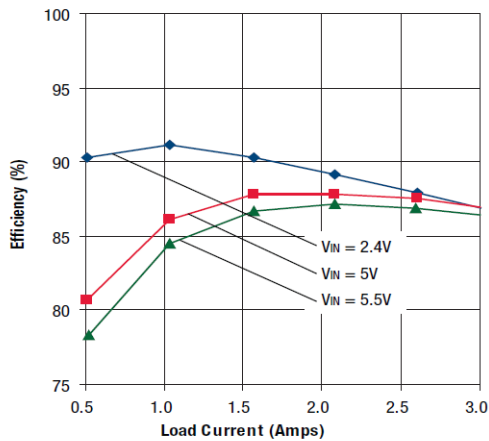

Maximum Current Temperature Derating at Sea Level
(Vin = 5V, Vout = 1.0V)

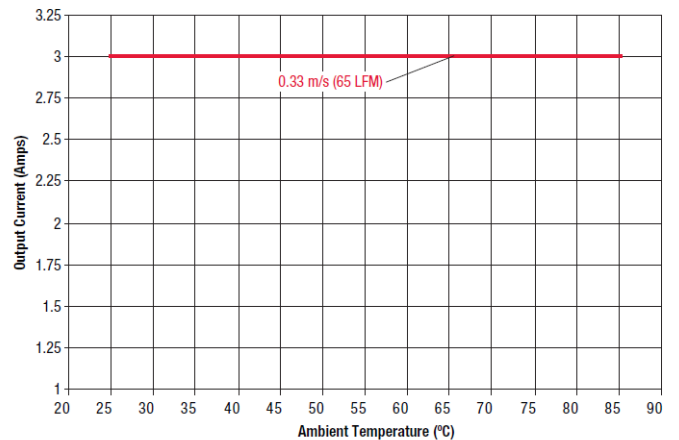

On/Off Enable Startup Delay (Vin = 5V, Vout = 1.0V, Iout = 3A, Cloud = 0)
Trace 4 = Enable In, Trace2 = Vout



Output Ripple and Noise (Vin = 5V, Vout = 1.0V, Iout = 3A, Cloud = 0, ScopeBW = 20MHz)

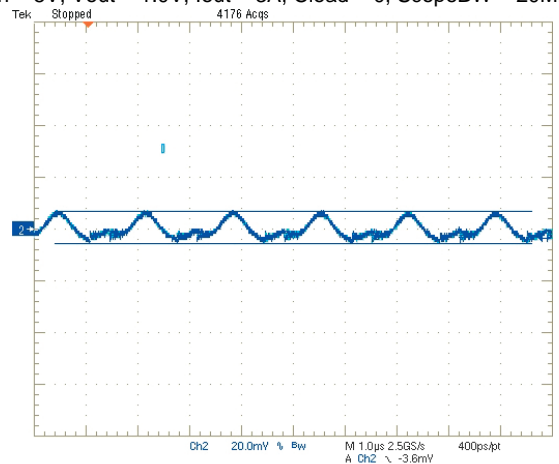

Step Load Transient Response (Vin = 5V, Vout = 1.0V, Cloud = 0, Iout = 1.5 to 3A)
Trace 2 = Vout, 100 mV/div. Trace 4 = Iout, 2.5A/div.

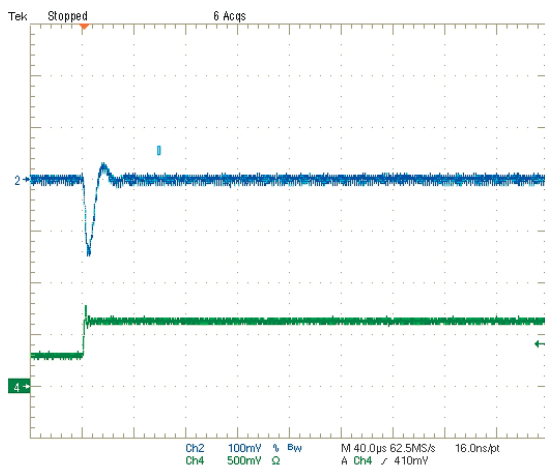

Step Load Transient Response (Vin = 5V, Vout = 1.0V, Cloud = 0, Iout = 3 to 1.5A)
Trace 2 = Vout, 100 mV/div. Trace 4 = Iout, 2.5A/div.

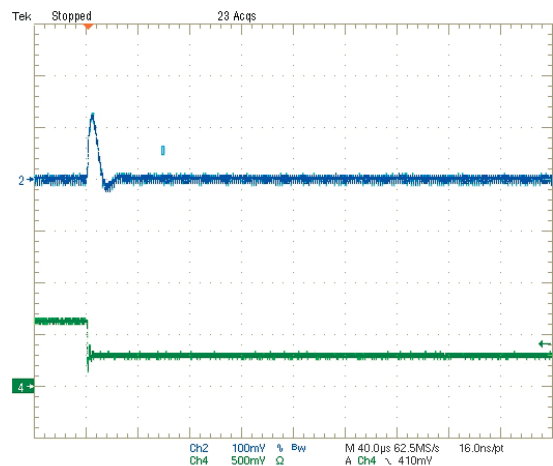

MECHANICAL SPECIFICATIONS

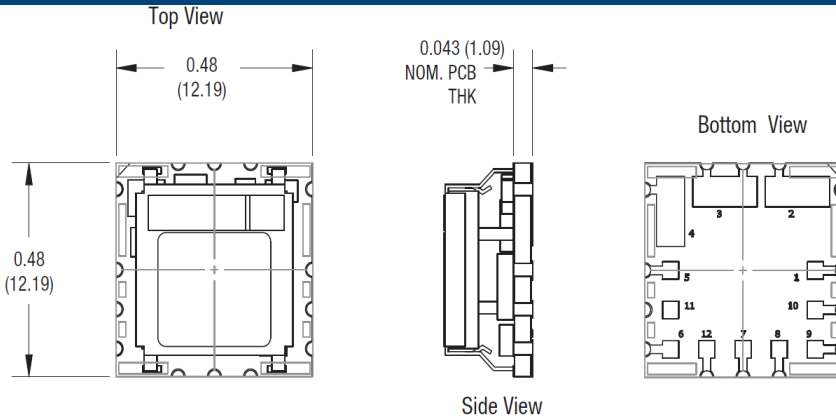

INPUT / OUTPUT CONNECTIONS		
P/N Pin	OKL-T/3-W12	OKL-T/3-W5
	Function	
1	On/Off Control (*1)	On/Off Control (*1)
2	V _{IN}	V _{IN}
3	Ground	Ground
4	V _{OUT}	V _{OUT}
5	Sense	Sense
6	Trim	Trim
7	Ground	Ground
8	No Connection	No Connection
9	Sequence/Tracking (*2)	Sequence/Tracking (*2)
10	Power Good out	No Connection
11	No Connection	No Connection
12	No Connection	No Connection

*1 The Remote On/Off can be provided with either positive (P suffix) or negative (N suffix) logic.
 *2 OKL2 models only

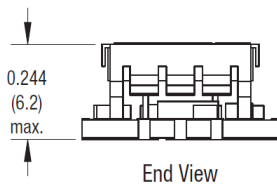

SOLDER PAD NOTES:

- [1] To avoid incorrect contacts with exposed via's and plated through holes on the bottom of the converter, do not have any exposed copper around the unit aside from our recommended footprint. Except for connections to the pads, keep all external circuits away from the board edge s.
- [2] Do not connect any additional components between the Trim pin and Vout or between the Trim and Sense pins. Use only the specified connections.

Bottom View

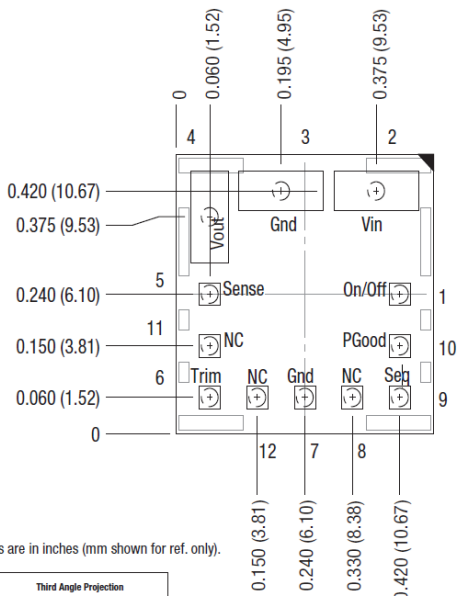

Dimensions are in inches (mm shown for ref. only).

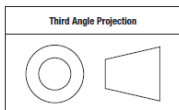

Tolerances (unless otherwise specified):
 .XX ± 0.02 (0.5)
 .XXX ± 0.010 (0.25)
 Angles ± 1°

Components are shown for reference only.

Plating Thickness:
 Gold overplate 1.18µ" (0.03µm)
 on Nickel subplate 118.1µ" (3.0µm)

**Recommended Footprint
 -through the Board-**

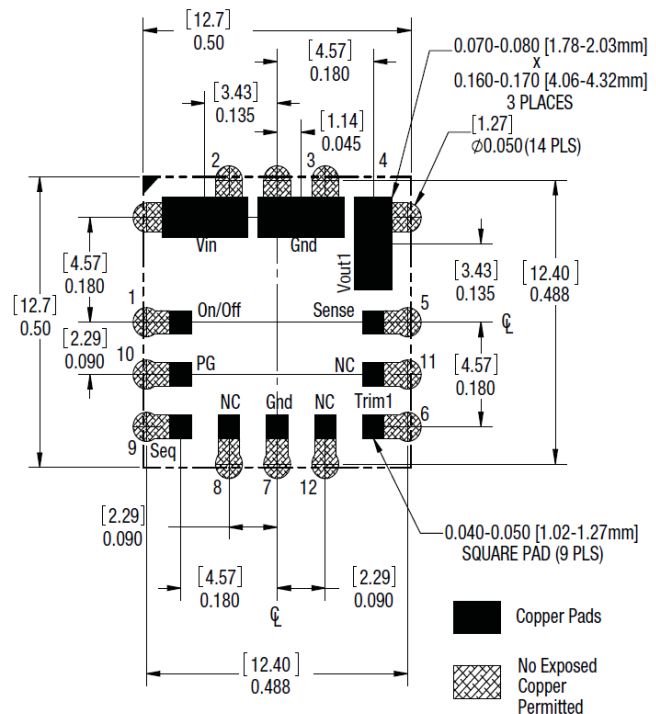
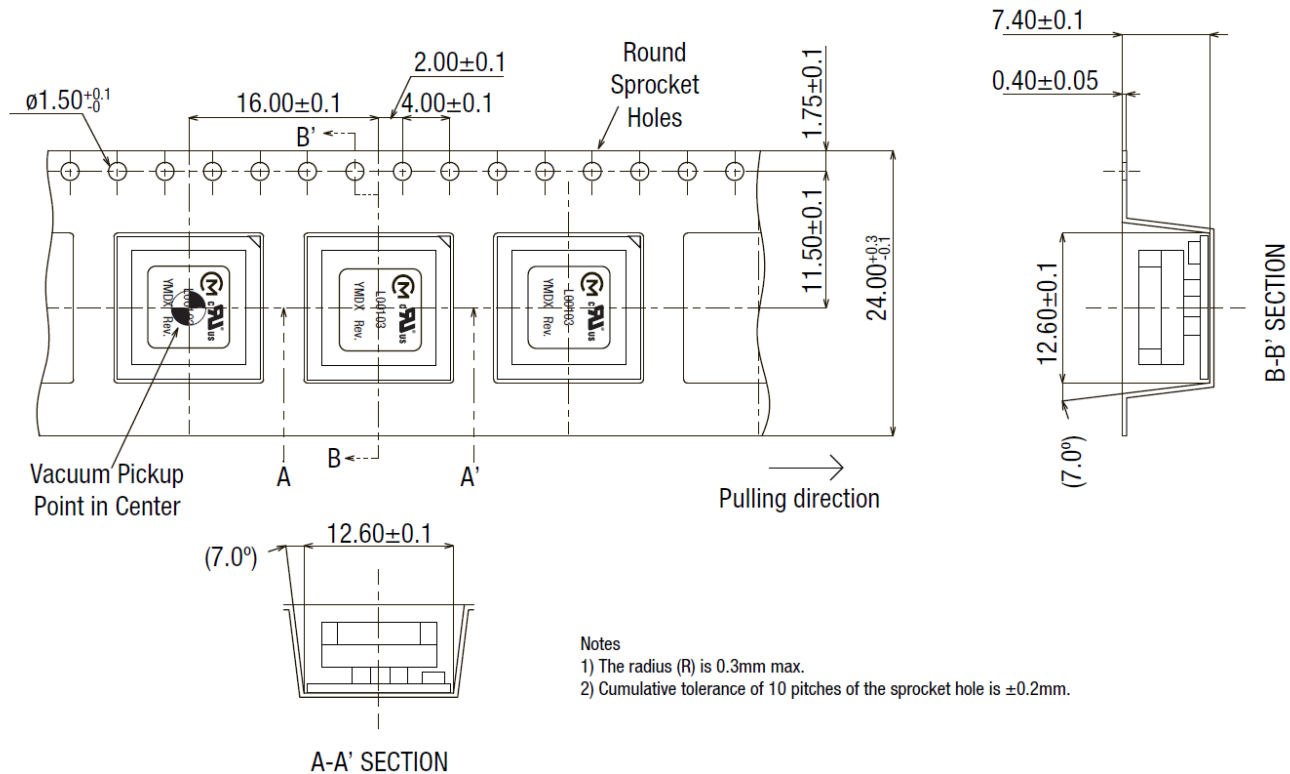

Figure 3. OKL-T/3 Mechanical Outline

TAPE AND REEL INFORMATION (MSL RATING 2)

Tape Details



Reel Details

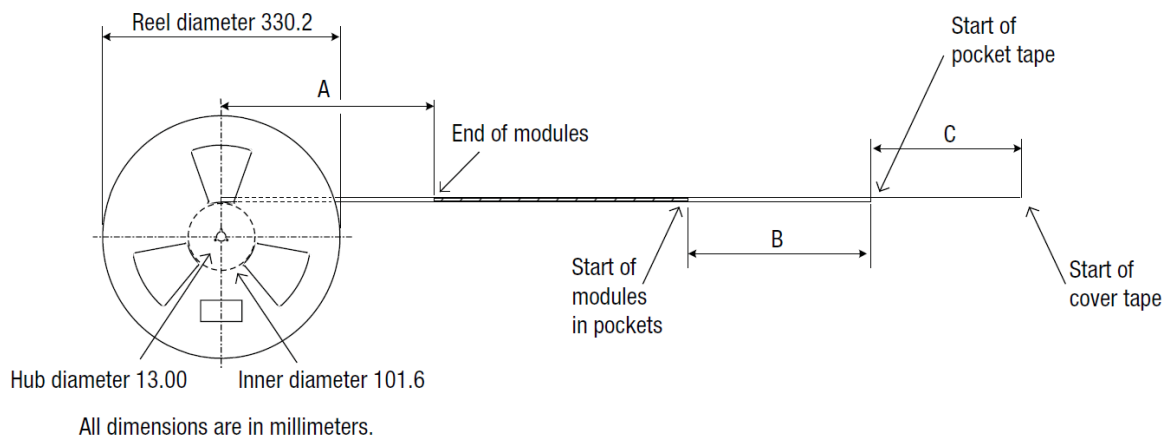

- Notes**
 1) The adhesive strength of the protective tape must be within 0.1-1.3N.
 2) The color of reel is not specified.

Reel Information (400 units per reel)

Key	Description	Length (mm)
A	Tape trailer (no modules)	800 \pm 40
B	Pocket tape length before modules	200 min.
C	Cover tape length before pocket tape	240 \pm 40

TECHNICAL NOTES

Output Voltage Adjustment

The output voltage may be adjusted over a limited range by connecting an external trim resistor (Rtrim) between the Trim pin and Ground. The Rtrim resistor is recommended to have a ±0.5% accuracy (or better) with low temperature coefficient, ±100 ppm/degC or better. Mount the resistor close to the converter with very short leads or use a surface mount trim resistor.

In the tables below, the calculated resistance is given. Do not exceed the specified limits of the output voltage or the converter's maximum power rating when applying these resistors. Also, avoid high noise at the Trim input. However, to prevent instability, you should never connect any capacitors to Trim.

OKL-T/3-W12

Output Voltage	Calculated Rtrim (KΩ)
5.0 V.	1.34
3.3 V.	2.18
2.5 V.	3.1
2.0 V.	4.19
1.8 V.	4.88
1.5 V.	6.50
1.2 V.	9.70
1.0 V.	14.45
0.591 V.	∞ (open)

Resistor Trim Equation, OKL-T/3-W12 models:

$$R_{TRIM} (k\Omega) = \frac{5.91}{V_{OUT} - 0.591}$$

OKL-T/3-W5

Output Voltage	Calculated Rtrim (KΩ)
3.3 V.	0.44
2.5 V.	0.63
2.0 V.	0.86
1.8 V.	1.0
1.5 V.	1.33
1.2 V.	2.0
1.0 V.	3.0
0.6 V.	∞ (open)

Resistor Trim Equation, OKL-T/3-W5 models:

$$R_{TRIM} (k\Omega) = \frac{1.2}{V_{OUT} - 0.6}$$

Do not connect any additional components between the Vtrim pin and Vout or between the Trim and Sense pins. Use only the specified connections as recommended per this data sheet.

Output voltage sensing

This function compensates for the voltage drop between the input and output of the load. By connecting the sense pin at the load, voltage drop caused by wiring is compensated.

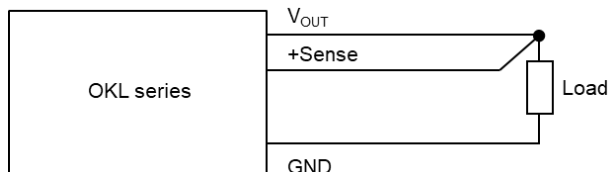

Do NOT connect the SENSE pin to the output of the LC filter on the Vout line. If connected this way, the product may not operate correctly.

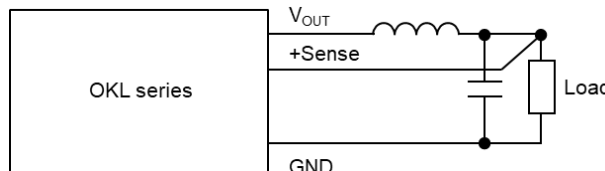

CAUTION: If the sense function is not used, please connect the Sense pin to the nearest Vout pin on the product.

Input Fusing

Certain applications and/or safety agencies may require fuses at the inputs of power conversion components. Fuses should also be used when there is the possibility of sustained input voltage reversal which is not current-limited. For greatest safety, we recommend a fast blow fuse installed in the ungrounded input supply line.

The installer must observe all relevant safety standards and regulations. For safety agency approvals, install the converter in compliance with the end-user safety standard.

Input Under-Voltage Shutdown and Start-Up Threshold

Under normal start-up conditions, converters will not begin to regulate properly until the ramping-up input voltage exceeds and remains at the Start-Up Threshold Voltage (see Specifications). Once operating, converters will not turn off until the input voltage drops below the Under-Voltage Shutdown Limit. Subsequent restart will not occur until the input voltage rises again above the Start-Up Threshold. This built-in hysteresis prevents any unstable on/off operation at a single input voltage.

Users should be aware however of input sources near the Under-Voltage Shutdown whose voltage decays as input current is consumed (such as capacitor inputs), the converter shuts off and then restarts as the external capacitor recharges. Such situations could oscillate. To prevent this, make sure the operating input voltage is well above the UV Shutdown voltage AT ALL TIMES.

Start-Up Time

Assuming that the output current is set at the rated maximum, the Vin to Vout Start-Up Time (see Specifications) is the time interval between the point when the ramping input voltage crosses the Start-Up Threshold and the fully loaded regulated output voltage enters and remains within its specified accuracy band. Actual measured times will vary with input source impedance, external input capacitance, input voltage slew rate and final value of the input voltage as it appears at the converter. These converters include a soft-start circuit to moderate the duty cycle of its PWM controller at power up, thereby limiting the input inrush current. The On/Off Remote Control interval from On command to Vout regulated assumes that the converter already has its input voltage stabilized above the Start-Up Threshold before the On command. The interval is measured from the On command until the output enters and remains within its specified accuracy band. The specification assumes that the output is fully loaded at maximum rated current. Similar conditions apply to the On to Vout regulated specification such as external load capacitance and soft-start circuitry.

Recommended Input Filtering

The user must assure that the input source has low AC impedance to provide dynamic stability and that the input supply has little or no inductive content, including long distributed wiring to a remote power supply. The converter will operate with no additional external capacitance if these conditions are met.

For best performance, we recommend installing a low-ESR capacitor immediately adjacent to the converter’s input terminals. The capacitor should be a ceramic type such as the Murata GRM32 series or a polymer type. Initial suggested capacitor values are 10 to 22 uF, rated at twice the expected maximum input voltage. Make sure that the input terminals do not go below the undervoltage shutdown voltage at all times. More input bulk capacitance may be added in parallel (either electrolytic or tantalum) if needed.

Recommended Output Filtering

The converter will achieve its rated output ripple and noise with no additional external capacitor. However, the user may install more external output capacitance to reduce the ripple even further or for improved dynamic response. Again, use low-ESR ceramic (Murata GRM32 series) or polymer capacitors. Initial values of 10 to 47 uF may be tried, either single or multiple capacitors in parallel. Mount these close to the converter. Measure the output ripple under your load conditions.

Use only as much capacitance as required to achieve your ripple and noise objectives. Excessive capacitance can make step load recovery sluggish or possibly introduce instability. Do not exceed the maximum rated output capacitance listed in the specifications.

Input Ripple Current and Output Noise

All models in this converter series are tested and specified for input reflected ripple current and output noise using designated external input/ output components, circuits and layout as shown in the figures below. The Cbus and Lbus components simulate a typical DC voltage bus. Please note that the values of Cin, Lbus and Cbus will vary according to the specific converter model.

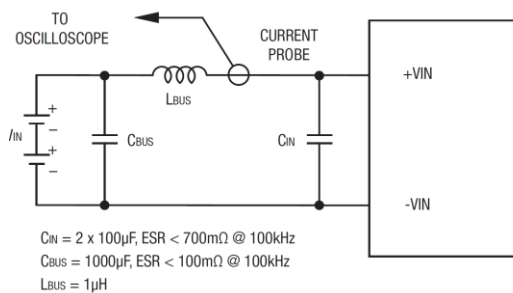

Figure 4. Measuring Input Ripple Current

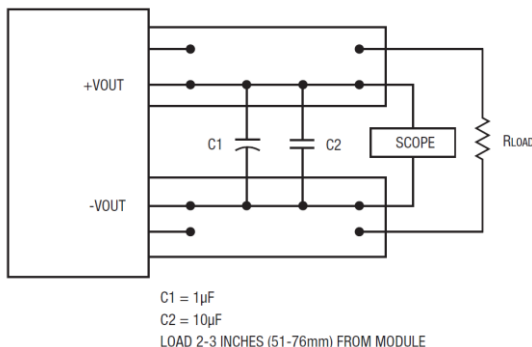

Figure 5. Measuring Output Ripple and Noise (PARD)

Minimum Output Loading Requirements

All models regulate within specification and are stable under no load to full load conditions. Operation under no load might however slightly increase output ripple and noise.

Thermal Shutdown

To prevent many over temperature problems and damage, these converters include thermal shutdown circuitry. If environmental conditions cause the temperature of the DC-DC’s to rise above the Operating Temperature Range up to the shutdown temperature, an on-board electronic temperature sensor will power down the unit. When the temperature decreases below the turn-on threshold, the converter will automatically restart. There is a small amount of hysteresis to prevent rapid on/off cycling.

CAUTION: If you operate too close to the thermal limits, the converter may shut down suddenly without warning. Be sure to thoroughly test your application to avoid unplanned thermal shutdown.

Temperature Derating Curves

The graphs in this data sheet illustrate typical operation under a variety of conditions. The Derating curves show the maximum continuous ambient air temperature and decreasing maximum output current which is acceptable under increasing forced airflow measured in Linear Feet per Minute (“LFM”). Note that these are AVERAGE measurements. The converter will accept brief increases in current or reduced airflow as long as the average is not exceeded.

Note that the temperatures are of the ambient airflow, not the converter itself which is obviously running at higher temperature than the outside air. Also note that very low flow rates (below about 25 LFM) are similar to “natural convection”, that is, not using fan-forced airflow.

Murata makes Characterization measurements in a closed cycle wind tunnel with calibrated airflow. We use both thermocouples and an infrared camera system to observe thermal performance.

CAUTION: These graphs are all collected at slightly above Sea Level altitude. Be sure to reduce the derating for higher density altitude.

Power Good Output (OKL-T/3-W12 only)

The PGood signal is an open drain output requiring a user’s external pullup resistor to +5V or less referred to -Vin. PGood indicates when the converter has stabilized and the output is approximately within regulation. PGood is TRUE (open drain, high impedance state) if the converter’s power output voltage within about +/-10% of the setpoint. When PGood is FALSE (saturated low impedance state, LOW), the output resides within about +0.4V or less referred to -Vin, depending on the pullup current.

Note that PGood does not directly measure an output overcurrent condition. However, gross overcurrent or output short circuit will set PGood to FALSE (less than +0.4V saturation, low impedance condition). Because of the open drain design, several converters may connect their PGood’s in parallel with a common external pullup resistor in a wired-OR method.

The following conditions will render PGood as FALSE (Low):

- +Vout is greater than 10% error from Vset.
- Soft-start is active and not yet complete.
- An input undervoltage is present at +Vin.
- An output short circuit has occurred.
- An over temperature (OT) condition has occurred.

At power up, before the converter has achieved stable regulation, PGood approximates a forward-biased diode to ground.

CAUTION: PGood is connected directly to the PWM controller and a small signal FET inside the PWM. Use electrostatic protection. The PWM may be destroyed by inadvertent static discharge or excess current into the PGood signal. Pull down current should be limited to 5 mA maximum and the external pullup voltage should never exceed +5V referred to the negative input, -Vin.

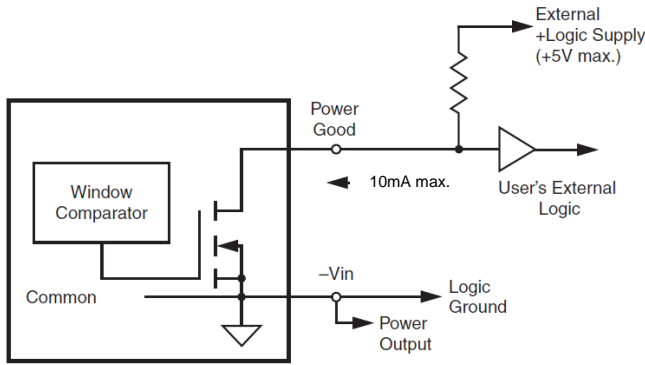

HI impedance (Open Drain) = Power Ok
 LO impedance (Saturation) = Power Not Ok

Figure 6. Power Good Circuit

Output Voltage Sequencing

The OKL modules include a sequencing feature that enables users to implement various types of output voltage sequencing in their applications. This is accomplished via an additional sequencing pin. When not using the sequencing feature, either tie the sequence pin to Vin or leave it unconnected.

When an analog voltage is applied to the sequence pin, the output voltage tracks this voltage until the output reaches the set-point voltage. The final value of the sequence voltage must be set higher than the set-point voltage of the module. The output voltage follows the voltage on the sequence pin on a one-to-one volt basis. By connecting multiple modules together, multiple modules can track their output voltages to the voltage applied on the sequence pin.

For proper voltage sequencing, first, input voltage is applied to the module. The On/Off pin of the module is left unconnected (or tied to GND for negative logic modules or tied to Vin for positive logic modules) so that the module is ON by default. After applying input voltage to the module, a minimum 10msec delay is required before applying voltage on the sequence pin. During this time, a voltage of 50mV (± 20 mV) is maintained on the sequence pin. This delay gives the module enough time to complete its internal powerup soft-start cycle. During the delay time, the sequence pin should be held close to ground (nominally 50mV ± 20 mV). This is required to keep the internal opamp out of saturation thus preventing output overshoot during the start of the sequencing ramp. By selecting resistor R1 according to the following equation

$$R1 = \frac{23500}{Vin - 0.05} \text{ ohms,}$$

the voltage at the sequencing pin will be 50mV when the sequencing signal is at zero. See Figure 7 for R1 connection for the sequencing signal to the SEQ pin.

[Click here to view Application Note DCAN-61](#)

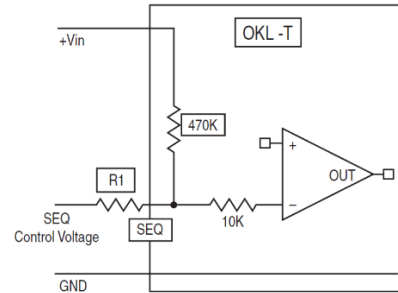
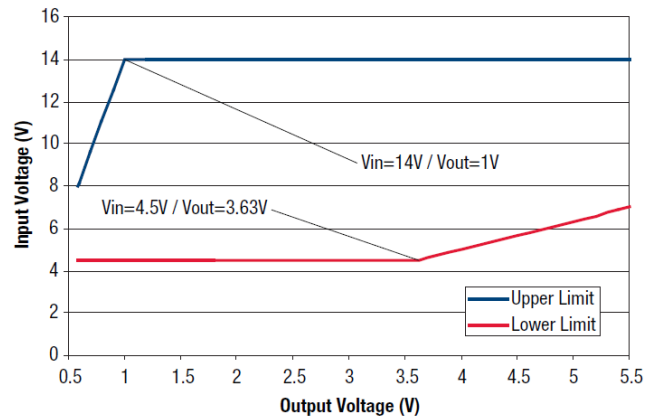

Figure 7. Sequencing Signal Interface of Module

Voltage Range Graph

Please observe the limits below for voltage input and output ranges. These limits apply at all output currents.



a) OKL-T/3-W12

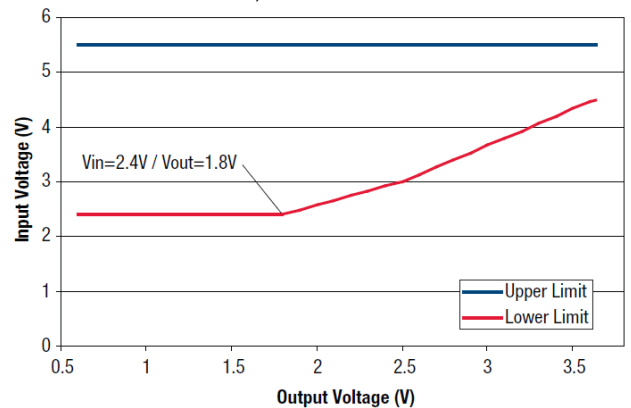

b) OKL-T/3-W5

Output Current Limiting

Current limiting inception is defined as the point at which full power falls below the rated tolerance. See the Performance/Functional Specifications. Note particularly that the output current may briefly rise above its rated value in normal operation as long as the average output power is not exceeded. This enhances reliability and continued operation of your application. If the output current is too high, the converter will enter the short circuit condition.

Output Short Circuit Condition

When a converter is in current-limit mode, the output voltage will drop as the output current demand increases.

Following a time-out period, the PWM will restart, causing the output voltage to begin rising to its appropriate value. If the short-circuit condition persists, another shutdown cycle will initiate. This rapid on/off cycling is called "hiccup mode". The hiccup cycling reduces the average output current, thereby preventing excessive internal temperatures and/or component damage.

The "hiccup" system differs from older latching short circuit systems because you do not have to power down the converter to make it restart. The system will automatically restore operation as soon as the short circuit condition is removed.

Remote On/Off Control

The OKL Series power modules can be specified with either a positive or negative logic type. See Figures 8 and 9 for On/Off circuit control. In the positive logic on/off option the unit turns on during a logic high on the On/Off pin and turns off during a logic low. In a negative logic on/off option, the unit turns off during logic high and on during logic low. The On/Off signal should always be reference to ground. For positive or negative option, leaving then On/Off pin disconnected will turn the unit on when input voltage is present.

Positive—Units are enabled when the on/off pin is left open or is pulled high to +Vin. The On/Off circuit control is shown in Figure 8. When the external transistor Q1 is in the off state, the internal PWM enable pin is pull high causing the unit to turn on. When Q1 is turn on, the On/Off pin is pulled low and the units is off. Rp should be around 20K ohms.

Negative—Units are enabled when the ON/Off is open or brought to within a low voltage (see specifications) with respect to -Vin. The unit is off when the ON/Off is pulled high with respect to -Vin (see specifications). The On/Off circuitry is shown in Figure 9. The On/Off pin should be pulled high with an external pull-up resistor (20K ohms or 8.2K ohm). When Q1 is in the off state, the On/Off pin is pulled high, an internal transistor is turn on and the unit is off. To turn on the unit, Q1 is turn on, pulling the On/Off pin low and turning the internal transistor off resulting on the unit being on.

Dynamic control of the On/Off function should be able to sink the specified signal current when brought low and withstand appropriate voltage when brought high. Be aware too that there is a finite time in milliseconds (see specifications) between the time of On/Off Control activation and stable, regulated output. This time will vary slightly with output load type and current and input conditions.

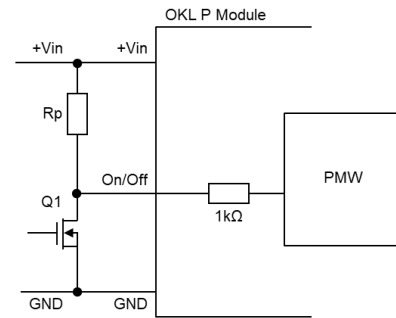

BOM → Rp → 20k
BOM → Q1 → Q SMT Nch-MOS 30V

a) OKL-T/3-W12

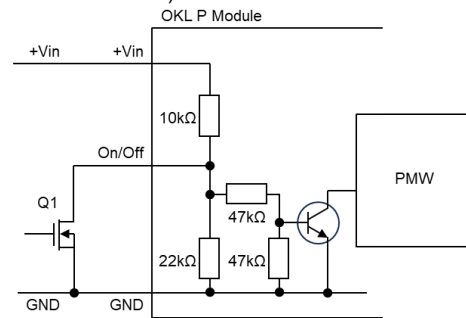

BOM → Q1 → Q SMT Nch-MOS 30V

b) OKL-T/3-W5

Figure 8. On/Off Circuit Control for Using Positive On/Off Logic

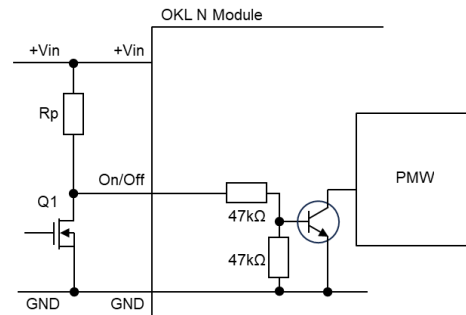

BOM → Rp → 20k
BOM → Q1 → Q SMT Nch-MOS 30V

a) OKL-T/3-W12

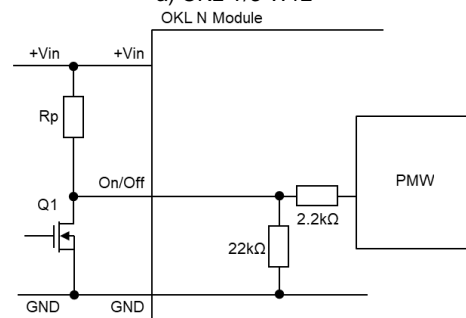

BOM → Rp → 8.2k
BOM → Q1 → Q SMT Nch-MOS 30V

b) OKL-T/3-W5

Figure 9. On/Off Circuit Control for Using Negative On/Off Logic

Output Capacitive Load

These converters do not require external capacitance added to achieve rated specifications. Users should only consider adding capacitance to reduce switching noise and/or to handle spike current load steps. Install only enough capacitance to achieve noise objectives. Excess external capacitance may cause regulation problems, degraded transient response and possible oscillation or instability.

Soldering Guidelines

Murata Power Solutions recommends the specifications below when installing these converters. These specifications vary depending on the solder type. Exceeding these specifications may cause damage to the product. Your production environment may differ therefore please thoroughly review these guidelines with your process engineers.

Reflow Solder Operations for surface-mount products (SMT)	
For Sn/Ag/Cu based solders:	
Preheat Temperature	Less than 1 degC per second
Time over Liquidus	60 to 150 seconds
Maximum Peak Temperature	260 degC
Cooling Rate	Less than 3 degC per second

Recommended Lead-free Solder Reflow Profile

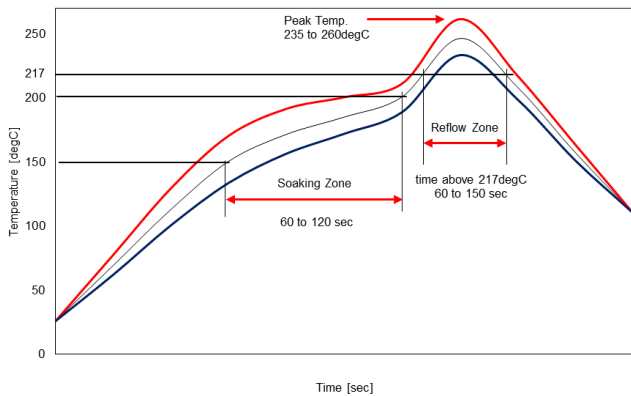

CAUTION: Do not reflow the DC-DC converter as follows, because the DC-DC converter may fall from the substrate during reflowing.

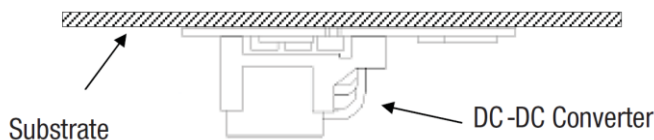

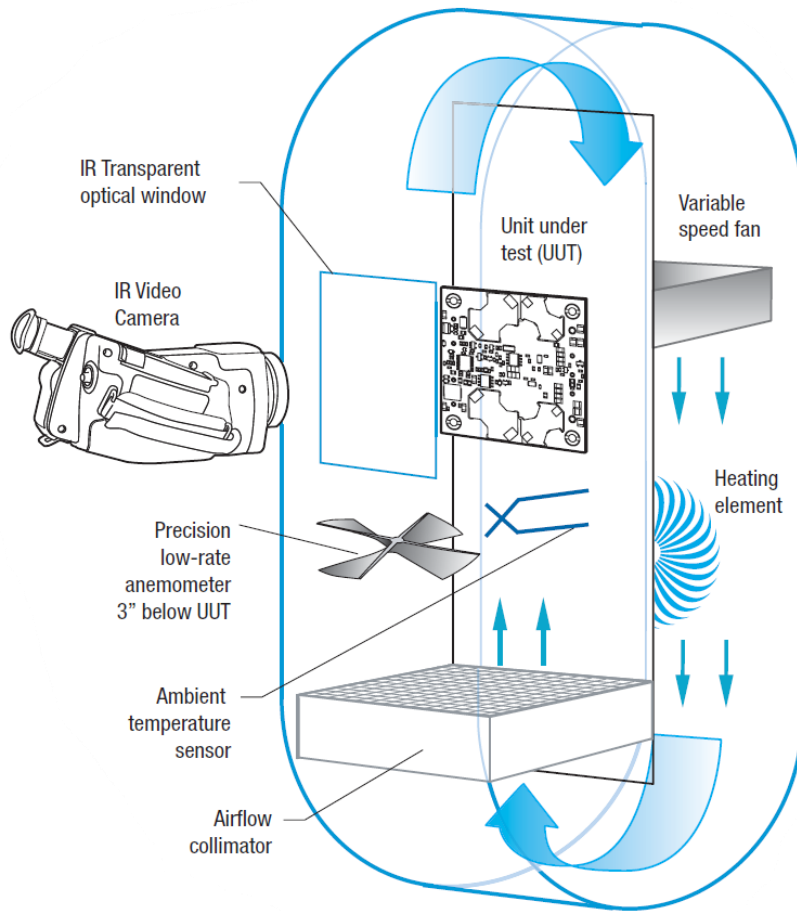

Figure 10. Vertical Wind Tunnel

Vertical Wind Tunnel

Murata Power Solutions employs a computer controlled custom-designed closed loop vertical wind tunnel, infrared video camera system, and test instrumentation for accurate airflow and heat dissipation analysis of power products. The system includes a precision low flow-rate anemometer, variable speed fan, power supply input and load controls, temperature gauges, and adjustable heating element.

The IR camera monitors the thermal performance of the Unit Under Test (UUT) under static steady-state conditions. A special optical port is used which is transparent to infrared wavelengths.

Both through-hole and surface mount converters are soldered down to a 10" x 10" host carrier board for realistic heat absorption and spreading. Both longitudinal and transverse airflow studies are possible by rotation of this carrier board since there are often significant differences in the heat dissipation in the two airflow directions. The combination of adjustable airflow, adjustable ambient heat, and adjustable Input/Output currents and voltages mean that a very wide range of measurement conditions can be studied.

The collimator reduces the amount of turbulence adjacent to the UUT by minimizing airflow turbulence. Such turbulence influences the effective heat transfer characteristics and gives false readings. Excess turbulence removes more heat from some surfaces and less heat from others, possibly causing uneven overheating.

Both sides of the UUT are studied since there are different thermal gradients on each side. The adjustable heating element and fan, built-in temperature gauges, and no-contact IR camera mean that power supplies are tested in real-world conditions.

Notices

Scope

The datasheet is applied to OKL-T/3-W12 series, OKL2-T/3-W12 series, OKL-T/3-W5 series and OKL2-T/3-W5 series.

- Specific applications: Consumer Electronics, Industrial Equipment

CAUTION

Limitation of Applications

The products listed in the datasheet (hereinafter the product is called the “Product”) are designed and manufactured for applications specified in the specification or the datasheet. (hereinafter called the “Specific Application”). We shall not warrant anything in connection with Products including fitness, performance, adequateness, safety, or quality, in the case of applications listed in from (1) to (11) written at the end of this precautions, which may generally require high performance, function, quality, management of production or safety. Therefore, Product shall be applied in compliance with the specific application.

We disclaim any loss and damages arising from or in connection with the products including but not limited to the case such loss and damages caused by the unexpected accident, in event that (i) the product is applied for the purpose which is not specified as the specific application for the product, and/or (ii) the product is applied for any following application purposes from (1) to (11) (except that such application purpose is unambiguously specified as specific application for the product in our catalog specification forms, datasheets, or other documents officially issued by us*).

- (1) Aircraft equipment
- (2) Aerospace equipment
- (3) Undersea equipment
- (4) Power plant control equipment
- (5) Medical equipment
- (6) Transportation equipment (such as vehicles, trains, ships)
- (7) Traffic control equipment
- (8) Disaster prevention/security equipment
- (9) Industrial data-processing equipment
- (10) Combustion/explosion control equipment
- (11) Equipment with complexity and required reliability equivalent to the applications listed in the above

For exploring information of the Products which will be compatible with the particular purpose other than those specified in the datasheet, please contact our sales offices, distribution agents, or trading companies with which you make a deal, or via our web contact form.

Contact form: <https://www.murata.com/contactform>

*We may design and manufacture particular products for applications listed in (1) to (11). Provided that, in such case we shall unambiguously specify such Specific Application in the specification or the datasheet without any exception. Therefore, any other documents and/or performances, whether exist or non-exist, shall not be deemed as the evidence to imply that we accept the applications listed in (1) to (11).

Storage

Please store the products in room where direct sunlight cannot come in and use the products within 6 months after delivery and maintain an appropriate storage condition using the following conditions.

- A temperature is +5 degC to +40 degC and a relative humidity is 20% to 70% as a standard condition. The temperature recommendation is less than 30 degC.
- If the storage period exceeds six months, check packaging, mounting, etc. before use.
- In addition, this may cause oxidation of the electrodes. If more than one year has elapsed since delivery, also check the solderability before use.
- Please do not store the products in the places such as : in a dusty place, in a place exposed directly to sea breeze, in an atmosphere containing corrosive gas (Cl₂, NH₃, SO₂, NO_x and so on).

This product is MSL2.

After opening bags, please store the products under maximum condition of 30degC, 60%RH and use the products within 1 year.

If the MSL floor life exceeds, it is recommended to proceed baking under the following conditions.

- 125 +10/-0 degC, 5 hours (for product)
- 40 degC, 5 %RH, 8 days (for reel packing or tray)

Fail-safe function

Be sure to add an appropriate fail-safe function to your finished product to prevent secondary damage in the unlikely event of an abnormality function or malfunction in our product.

Please connect the input terminal by right polarity. If you mistake the connection, it may break the DC-DC converter. In the case of destruction of the DC-DC converter inside, input over-current may flow. Please add a diode and fuse as following to protect them.

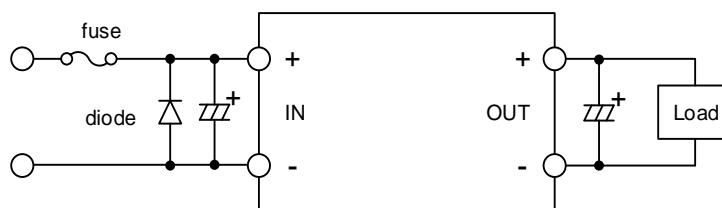

Please select diode and fuse after confirming the operation.

Figure 11. Circuit example with a diode and fuse

⚠ Note

1. Please make sure that your product has been evaluated in view of your specifications with our product being mounted to your product.
2. You are requested not to use our product deviating from the reference specifications.
3. If you have any concerns about materials other than those listed in the RoHS directive, please contact us.
4. Be sure to provide an appropriate fail-safe function on your product to prevent a second damage that may be caused by the abnormal function or the failure of our product.
5. Please don't wash this product under any conditions.

Product Specification

Product Specification in this datasheet are as of February 2026. Specifications and features may change in any manner without notice. Please check with our sales representatives.

Contact Form

<https://www.murata.com/contactform?Product=Power%20Device>

Disclaimers

The information described in this data sheet was carefully crafted for accuracy. However this product is based on the assumption that it will be used after thoroughly verifying and confirming the characteristics and system compatibility. Therefore, Murata is not responsible for any damages caused by errors in the description of the datasheet.

Murata constantly strives to improve the quality and reliability of our products, but it is inevitable that semiconductor products will fail with a certain probability. Therefore, regardless of whether the use conditions are within the range of this data sheet, Murata is not responsible for any damage caused by the failure of this product. (for example, secondary damage, compensation for accidents, punitive damage, loss of opportunity, and etc.) Also, regardless of whether Murata can foresee the events caused by the failure of our product, Murata has no obligations or responsibilities.

The buyer of this product and developer of systems incorporating this product must analyze, evaluate, and make judgements at their own risk in designing applications using this product. The buyer and the developer are responsible for verifying the safety of this product and the applications, and complying with all applicable laws, regulations, and other requirements.

Furthermore, the buyer and developer are responsible for predicting hazards and taking adequate safeguards against potential events at your own risk in order to prevent personal accidents, fire accidents, or other social damage. When using this product, perform thorough evaluation and verification of the safety design designed at your own risk for this product and the application.

Murata assumes that the buyer and developer have the expertise to verify all necessary issues for proper use of the product as described above and to take corrective action. Therefore, Murata has no liability arising out of the use of the product. The buyer and developer should take all necessary evaluations, verifications, corrective actions and etc., in your own responsibility and judgment.

This data sheet does not guarantee or grant any license to the information, including patents, copyrights, and other intellectual property rights, of the Murata or third parties. Regardless of whether the information described in this datasheet is express or implied, Murata does not take any responsibility or liability for any claims, damages, costs, losses, etc. relating to intellectual property rights or other rights from third parties due to the use of these information.

Patent Statement

Murata products are protected under one or more of the U.S. patents.

Copyright and Trademark

©2026 Murata Manufacturing Co., Ltd. All rights reserved.

Murata Power Solutions, Inc.
129 Flanders Rd., Westborough, MA 01581 U.S.A.
ISO 9001 and 14001 REGISTERED





This product is subject to the following operating requirements and the Life and Safety Critical Application Sales Policy:
Refer to: <https://power.murata.com/en/requirements>

Murata Manufacturing Co., Ltd makes no representation that the use of its products in the circuits described herein, or the use of other technical information contained herein, will not infringe upon existing or future patent rights. The descriptions contained herein do not imply the granting of licenses to make, use, or sell equipment constructed in accordance therewith.

Looking for pricing, stock, or lifecycle information?

Click below to explore more details on WIN SOURCE:

-  [View OKL-T/3-W12P-C on WIN SOURCE](#)
-  [Murata Power Solutions Inc. Information](#)

Optimize Your Supply Chain with WIN SOURCE Solutions

-  Global Sourcing Solution
-  Obsolete Management
-  Cost Control Management
-  Shortage Management
-  Alternative Solution
-  Excess Inventory Management