



**THE DATASHEET OF
ICS951416AFLF**





System Clock Chip for ATI RS480

Recommended Application:

ATI RS480 systems using AMD K8 processors

Output Features:

- 3 - 14.318 MHz REF clocks
- 1 - USB_48MHz USB clock
- 1 - HyperTransport 66 MHz clock seed
- 1 - PCI 33 MHz clock seed
- 2 - Pairs of AMD K8 clocks
- 6 - Pairs of SRC/PCI Express* clocks
- 2 - Pairs of ATIG (SRC/PCI Express) clocks

Features:

- 2 - Programmable Clock Request pins for SRC clocks
- ATIGCLKS are programmable for frequency
- Spread Spectrum for EMI reduction
- Outputs may be disabled via SMBus
- External crystal lead capacitors for maximum frequency accuracy

Pin Configuration

X1	1	56	VDDREF
X2	2	55	GND
VDD48	3	54	**FS0/REF0
USB_48MHz	4	53	**FS1/REF1
GND	5	52	REF2
NC	6	51	VDDPCI
SCLK	7	50	PCICLK0
SDATA	8	49	GNDPCI
**FS2	9	48	VDDHTT
**CLKREQA#	10	47	HTTCLK0
**CLKREQB#	11	46	GNDHTT
SRCCLKT7	12	45	CPUCLK8T0
SRCCLKC7	13	44	CPUCLK8C0
VDDSRC	14	43	VDDCPU
GNDSRC	15	42	GNDCPU
SRCCLKT6	16	41	CPUCLK8T1
SRCCLKC6	17	40	CPUCLK8C1
SRCCLKT5	18	39	VDDA
SRCCLKC5	19	38	GND A
GNDSRC	20	37	IREF
VDDSRC	21	36	GNDSRC
SRCCLKT4	22	35	VDDSRC
SRCCLKC4	23	34	SRCCLKT0
SRCCLKT3	24	33	SRCCLKC0
SRCCLKC3	25	32	VDDATI
GNDSRC	26	31	GNDATI
ATIGCLKT1	27	30	ATIGCLKT0
ATIGCLKC1	28	29	ATIGCLKC0

ICS951416

Note: Pins preceded by *** have a 120 Kohm Internal Pull Down resistor

56 Pin SSOP/TSSOP

Power Groups

Pin Number		Description
VDD	GND	
56	55	Xtal, REF
51	49	PCICLK output
48	46	HTTCLK output
43	42	CPU Outputs
14, 21, 32,35	15, 20, 26,31,36	SRC outputs
39	38	Analog, CPU PLL
3	5	USB_48MHz output

Functionality

FS2	FS1	FS0	CPU	HTT	PCI
			MHz	MHz	MHz
0	0	0	Hi-Z	Hi-Z	Hi-Z
0	0	1	X	X/3	X/6
0	1	0	180.00	60.00	30.00
0	1	1	220.00	73.12	36.56
1	0	0	100.00	66.66	33.33
1	0	1	133.33	66.66	33.33
1	1	1	200.00	66.66	33.33



Pin Descriptions

PIN #	PIN NAME	PIN TYPE	DESCRIPTION
1	X1	IN	Crystal input, Nominally 14.318MHz.
2	X2	OUT	Crystal output, Nominally 14.318MHz
3	VDD48	PWR	Power pin for the 48MHz output.3.3V
4	USB_48MHz	OUT	48.00MHz USB clock
5	GND	PWR	Ground pin.
6	NC	N/A	No Connection.
7	SCLK	IN	Clock pin of SMBus circuitry, 5V tolerant.
8	SDATA	I/O	Data pin for SMBus circuitry, 5V tolerant.
9	**FS2	IN	Frequency select pin.
10	**CLKREQA#	IN	Output enable for PCI Express (SRC) outputs. SMBus selects which outputs are controlled. 0 = enabled, 1 = tri-stated
11	**CLKREQB#	IN	Output enable for PCI Express (SRC) outputs. SMBus selects which outputs are controlled. 0 = enabled, 1 = tri-stated
12	SRCCLKT7	OUT	True clock of differential SRC clock pair.
13	SRCCLKC7	OUT	Complement clock of differential SRC clock pair.
14	VDDSRC	PWR	Supply for SRC clocks, 3.3V nominal
15	GNDSRC	PWR	Ground pin for the SRC outputs
16	SRCCLKT6	OUT	True clock of differential SRC clock pair.
17	SRCCLKC6	OUT	Complement clock of differential SRC clock pair.
18	SRCCLKT5	OUT	True clock of differential SRC clock pair.
19	SRCCLKC5	OUT	Complement clock of differential SRC clock pair.
20	GNDSRC	PWR	Ground pin for the SRC outputs
21	VDDSRC	PWR	Supply for SRC clocks, 3.3V nominal
22	SRCCLKT4	OUT	True clock of differential SRC clock pair.
23	SRCCLKC4	OUT	Complement clock of differential SRC clock pair.
24	SRCCLKT3	OUT	True clock of differential SRC clock pair.
25	SRCCLKC3	OUT	Complement clock of differential SRC clock pair.
26	GNDSRC	PWR	Ground pin for the SRC outputs
27	ATIGCLKT1	OUT	True clock of differential SRC clock pair.
28	ATIGCLKC1	OUT	Complementary clock of differential SRC clock pair.

**Pin Descriptions (Continued)**

PIN #	PIN NAME	TYPE	DESCRIPTION
29	ATIGCLKC0	OUT	Complementary clock of differential SRC clock pair.
30	ATIGCLKT0	OUT	True clock of differential SRC clock pair.
31	GNDATI	PWR	Ground for ATI Gclocks, nominal 3.3V
32	VDDATI	PWR	Power supply ATI Gclocks, nominal 3.3V
33	SRCCLKC0	OUT	Complement clock of differential SRC clock pair.
34	SRCCLKT0	OUT	True clock of differential SRC clock pair.
35	VDDSRC	PWR	Supply for SRC clocks, 3.3V nominal
36	GNDSRC	PWR	Ground pin for the SRC outputs
37	IREF	OUT	This pin establishes the reference current for the differential current-mode output pairs. This pin requires a fixed precision resistor tied to ground in order to establish the appropriate current. 475 ohms is the standard value.
38	GND A	PWR	Ground pin for the PLL core.
39	VDD A	PWR	3.3V power for the PLL core.
40	CPUCLK8C1	OUT	Complementary clock of differential 3.3V push-pull K8 pair.
41	CPUCLK8T1	OUT	True clock of differential 3.3V push-pull K8 pair.
42	GND CPU	PWR	Ground pin for the CPU outputs
43	VDD CPU	PWR	Supply for CPU clocks, 3.3V nominal
44	CPUCLK8C0	OUT	Complementary clock of differential 3.3V push-pull K8 pair.
45	CPUCLK8T0	OUT	True clock of differential 3.3V push-pull K8 pair.
46	GND HTT	PWR	Ground pin for the HTT outputs
47	HTTCLK0	OUT	3.3V Hyper Transport output
48	VDD HTT	PWR	Supply for HTT clocks, nominal 3.3V.
49	GND PCI	PWR	Ground pin for the PCI outputs
50	PCI CLK0	OUT	PCI clock output.
51	VDD PCI	PWR	Power supply for PCI clocks, nominal 3.3V
52	REF2	OUT	14.318 MHz reference clock.
53	**FS1/REF1	I/O	Frequency select latch input pin / 14.318 MHz reference clock.
54	**FS0/REF0	I/O	Frequency select latch input pin / 14.318 MHz reference clock.
55	GND	PWR	Ground pin.
56	VDD REF	PWR	Ref, XTAL power supply, nominal 3.3V



General Description

The **ICS951416** is a main clock synthesizer chip that provides all clocks required for ATI RS480-based systems.

An SMBus interface allows full control of the device.

Block Diagram

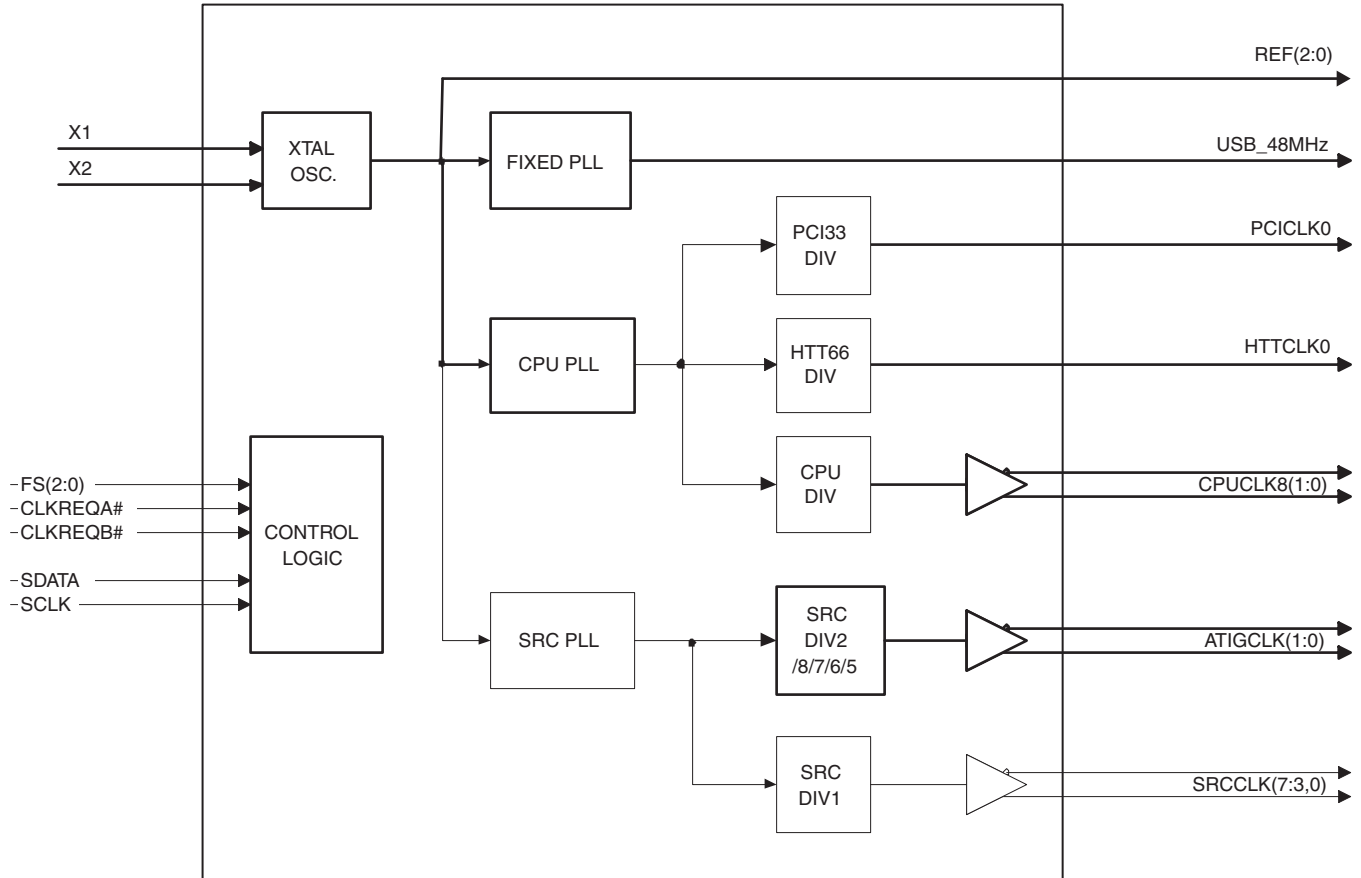



General SMBus serial interface information

How to Write:

- Controller (host) sends a start bit.
- Controller (host) sends the write address $D2_{(H)}$
- ICS clock will **acknowledge**
- Controller (host) sends the beginning byte location = N
- ICS clock will **acknowledge**
- Controller (host) sends the data byte count = X
- ICS clock will **acknowledge**
- Controller (host) starts sending **Byte N through Byte N + X - 1**
(see Note 2)
- ICS clock will **acknowledge** each byte **one at a time**
- Controller (host) sends a Stop bit

How to Read:

- Controller (host) will send start bit.
- Controller (host) sends the write address $D2_{(H)}$
- ICS clock will **acknowledge**
- Controller (host) sends the beginning byte location = N
- ICS clock will **acknowledge**
- Controller (host) will send a separate start bit.
- Controller (host) sends the read address $D3_{(H)}$
- ICS clock will **acknowledge**
- ICS clock will send the data byte count = X
- ICS clock sends **Byte N + X - 1**
- ICS clock sends **Byte 0 through byte X (if $X_{(H)}$ was written to byte 8)**.
- Controller (host) will need to acknowledge each byte
- Controller (host) will send a not acknowledge bit
- Controller (host) will send a stop bit

Index Block Write Operation			
Controller (Host)		ICS (Slave/Receiver)	
T	starT bit		
Slave Address $D2_{(H)}$			
WR	WRite		
		ACK	
Beginning Byte = N			
		ACK	
Data Byte Count = X			
		ACK	
Beginning Byte N		X Byte	
			ACK
○			○
○			○
○			○
Byte N + X - 1			
		ACK	
P	stoP bit		

Index Block Read Operation			
Controller (Host)		ICS (Slave/Receiver)	
T	starT bit		
Slave Address $D2_{(H)}$			
WR	WRite		
		ACK	
Beginning Byte = N			
		ACK	
RT	Repeat starT		
Slave Address $D3_{(H)}$			
RD	ReaD		
		ACK	
		Data Byte Count = X	
ACK			
		X Byte	
ACK			Beginning Byte N
○			○
○			○
○			○
		Byte N + X - 1	
N	Not acknowledge		
P	stoP bit		



Table1: CPU Frequency Selection Table

CPU FS4 (B0:b4)	CPU FS3 (B0:b3)	Bit2 FS2	Bit1 FS1	Bit0 FS0	CPU (MHz)	HTT66 (MHz)	PCI33 (MHz)	Spread %
0	0	0	0	0	Hi-Z	Hi-Z	Hi-Z	None
0	0	0	0	1	X/6	X/12	X/24	None
0	0	0	1	0	180.00	60.00	30.00	None
0	0	0	1	1	220.00	73.33	36.67	None
0	0	1	0	0	100.00	66.67	33.33	None
0	0	1	0	1	133.33	66.67	33.33	None
0	0	1	1	0	166.67	66.67	33.33	None
0	0	1	1	1	200.00	66.67	33.33	None
0	1	0	0	0	186.00	62.00	31.00	None
0	1	0	0	1	214.00	71.33	35.67	None
0	1	0	1	0	190.00	63.33	31.67	None
0	1	0	1	1	210.00	70.00	35.00	None
0	1	1	0	0	102.00	68.00	34.00	None
0	1	1	0	1	136.00	68.00	34.00	None
0	1	1	1	0	170.00	68.00	34.00	None
0	1	1	1	1	204.00	68.00	34.00	None
1	0	0	0	0	169.58	56.53	28.26	-0.5%
1	0	0	0	1	229.43	76.48	38.24	-0.5%
1	0	0	1	0	179.55	59.85	29.93	-0.5%
1	0	0	1	1	219.45	73.15	36.58	-0.5%
1	0	1	0	0	99.75	66.50	33.25	-0.5%
1	0	1	0	1	133.00	66.50	33.25	-0.5%
1	0	1	1	0	166.25	66.50	33.25	-0.5%
1	0	1	1	1	199.50	66.50	33.25	-0.5%
1	1	0	0	0	185.54	61.85	30.92	-0.5%
1	1	0	0	1	106.73	71.16	35.58	-0.5%
1	1	0	1	0	189.53	63.18	31.59	-0.5%
1	1	0	1	1	209.48	69.83	34.91	-0.5%
1	1	1	0	0	101.75	67.83	33.92	-0.5%
1	1	1	0	1	135.66	67.83	33.91	-0.5%
1	1	1	1	0	169.58	67.83	33.92	-0.5%
1	1	1	1	1	203.49	67.83	33.92	-0.5%



Table2: SRC & ATIG Frequency Selection Table

Byte 5					SRC(7:3,0), ATIG(1:0) (MHz)	Spread %	SRC OverClock
Bit4	Bit3	Bit2	Bit1	Bit0			
SRC FS4 Spread Enable	SRC FS3	SRC FS2	SRC FS1	SRC FS0			
0	0	0	0	0	100.00	0	1.00
0	0	0	0	1	100.00	0	1.00
0	0	0	1	0	100.00	0	1.00
0	0	0	1	1	100.00	0	1.00
0	0	1	0	0	101.00	0	1.01
0	0	1	0	1	101.00	0	1.01
0	0	1	1	0	101.00	0	1.01
0	0	1	1	1	101.00	0	1.01
0	1	0	0	0	102.00	0	1.02
0	1	0	0	1	102.00	0	1.02
0	1	0	1	0	102.00	0	1.02
0	1	0	1	1	102.00	0	1.02
0	1	1	0	0	104.00	0	1.04
0	1	1	0	1	104.00	0	1.04
0	1	1	1	0	104.00	0	1.04
0	1	1	1	1	104.00	0	1.04
1	0	0	0	0	99.75	-0.5%	1.00
1	0	0	0	1	99.75	-0.5%	1.00
1	0	0	1	0	99.75	-0.5%	1.00
1	0	0	1	1	99.75	-0.5%	1.00
1	0	1	0	0	100.74	-0.5%	1.01
1	0	1	0	1	100.74	-0.5%	1.01
1	0	1	1	0	100.74	-0.5%	1.01
1	0	1	1	1	100.74	-0.5%	1.01
1	1	0	0	0	101.74	-0.5%	1.02
1	1	0	0	1	101.74	-0.5%	1.02
1	1	0	1	0	101.74	-0.5%	1.02
1	1	0	1	1	101.74	-0.5%	1.02
1	1	1	0	0	103.74	-0.5%	1.04
1	1	1	0	1	103.74	-0.5%	1.04
1	1	1	1	0	103.74	-0.5%	1.04
1	1	1	1	1	103.74	-0.5%	1.04



Table 3: CPU Divider Ratios

Divider (1:0)	Divider (3:2)								
	Bit	00		01		10		11	MSB
	00	0000	2	0100	4	1000	8	1100	16
	01	0001	3	0101	6	1001	12	1101	24
	10	0010	5	0110	10	1010	20	1110	40
	11	0011	15	0111	30	1011	60	1111	120
LSB	Address	Div	Address	Div	Address	Div	Address	Div	

Table 4: HTT Divider Ratios

Divider (1:0)	Divider (3:2)								
	Bit	00		01		10		11	MSB
	00	0000	4	0100	8	1000	16	1100	32
	01	0001	3	0101	6	1001	12	1101	24
	10	0010	5	0110	10	1010	20	1110	40
	11	0011	15	0111	30	1011	60	1111	120
LSB	Address	Div	Address	Div	Address	Div	Address	Div	

Table 5: SRC, ATIG Divider Ratios

Divider (1:0)	Divider (3:2)								
	Bit	00		01		10		11	MSB
	00	0000	2	0100	4	1000	8	1100	16
	01	0001	3	0101	6	1001	12	1101	24
	10	0010	5	0110	10	1010	20	1110	40
	11	0011	7	0111	14	1011	28	1111	56
LSB	Address	Div	Address	Div	Address	Div	Address	Div	

Table 6: Group Skews

	Parameter	Description	Test Conditions	Skew Window	Unit
m e l i n d e p e n d e n t	Tsk_CPU_CPU	CPU to CPU Skew	Measured at crossing points of CPUCLKT rising edges	250	ps
	Tsk_CPU_PCI	CPU to PCI skew	Measured at crossing point for CPUCLKT and 1.5V for PCI clock	2000	ps
	Tsk_PCI33-HT66	PCI33 to HT66 skew	Measured between rising edges at 1.5V	500	ps
	Tsk_CPU_HT66	CPU to HT66 skew	Measured at crossing point for CPUCLKT and 1.5V for HT66 clock	2000	ps
T i m e v a r i a n t	Tsk_CPU_CPU	CPU to CPU Skew	Measured at crossing points of CPUCLKT rising edges	200	ps
	Tsk_CPU_PCI	CPU to PCI skew	Measured at crossing point for CPUCLKT and 1.5V for PCI clock	200	ps
	Tsk_PCI33-HT66	PCI33 to HT66 skew	Measured between rising edges at 1.5V	200	ps
	Tsk_CPU_HT66	CPU to HT66 skew	Measured at crossing point for CPUCLKT and 1.5V for HT66 clock	200	ps
	Tsk_SRC_SRC	SRC to SRC skew	Measured at crossing point for SRCCLKT	N/A	ps



SMBus Table: Frequency Select Register

Byte 0	Pin #	Name	Control Function	Type	0	1	PWD
Bit 7	-	FS Source	Latched Input or SMBus Frequency Select	RW	Latched Inputs	SMBus	0
Bit 6	-	SS_EN	PLL Spread Enable	RW	OFF	ON	0
Bit 5	-	Reserved	Reserved	RW	Reserved	Reserved	0
Bit 4	-	FS4	Freq Select Bit 4	RW	See Table 1: CPU Frequency Selection		0
Bit 3	-	FS3	Freq Select Bit 3	RW			0
Bit 2	-	FS2	Freq Select Bit 2	RW			Latched
Bit 1	-	FS1	Freq Select Bit 1	RW			Latched
Bit 0	-	FS0	Freq Select Bit 0	RW			Latched

Note: Byte 0 Bit 6, Byte 0 Bit 4 and Byte 5 Bit 4 must be set to '1' to fully enable spread.

SMBus Table: Output Control Register

Byte 1	Pin #	Name	Control Function	Type	0	1	PWD
Bit 7	50	PCICLK0	Output Enable	RW	Disable	Enable	1
Bit 6	47	HTTCLK0	Output Enable	RW	Disable	Enable	1
Bit 5	4	USB_48MHz	Output Enable	RW	Disable	Enable	1
Bit 4	54	REF0	Output Enable	RW	Disable	Enable	1
Bit 3	53	REF1	Output Enable	RW	Disable	Enable	1
Bit 2	52	REF2	Output Enable	RW	Disable	Enable	1
Bit 1	45,44	CPUCLK8(0)	Output Enable	RW	Disable	Enable	1
Bit 0	41,40	CPUCLK8(1)	Output Enable	RW	Disable	Enable	1

SMBus Table: CLKREQB# Output Control Register

Byte 2	Pin #	Name	Control Function	Type	0	1	PWD
Bit 7	12,13	REQBSRC7	CLKREQB# Controls SRC7	RW	Does not control	Controls	0
Bit 6	16,17	REQBSRC6	CLKREQB# Controls SRC6	RW	Does not control	Controls	0
Bit 5	18,19	REQBSRC5	CLKREQB# Controls SRC5	RW	Does not control	Controls	0
Bit 4	22,23	REQBSRC4	CLKREQB# Controls SRC4	RW	Does not control	Controls	0
Bit 3	24,25	REQBSRC3	CLKREQB# Controls SRC3	RW	Does not control	Controls	0
Bit 2	-	Reserved	Reserved	RW	Reserved	Reserved	X
Bit 1	-	Reserved	Reserved	RW	Reserved	Reserved	X
Bit 0	34,33	REQBSRC0	CLKREQB# Controls SRC0	RW	Does not control	Controls	0



SMBus Table: SRCCLK(7:3,0), CLKREQA# Output Control Register

Byte 3	Pin #	Name	Control Function	Type	0	1	PWD
Bit 7	12,13	SRCCLK7	Master Output control. Enables or disables output, regardless of CLKREQ# inputs.	RW	Disable	Enable	1
Bit 6	16,17	SRCCLK6		RW	Disable	Enable	1
Bit 5	18,19	SRCCLK5		RW	Disable	Enable	1
Bit 4	22,23	SRCCLK4		RW	Disable	Enable	1
Bit 3	24,25	SRCCLK3		RW	Disable	Enable	1
Bit 2	34,33	SRCCLK0		RW	Disable	Enable	1
Bit 1	24,25	REQASRC3	CLKREQA# Controls SRC3	RW	Does not control	Controls	0
Bit 0	34,33	REQASRC0	CLKREQA# Controls SRC0	RW	Does not control	Controls	0

SMBus Table: SRCCLK(3,0), ATIGCLK Output Control Register

Byte 4	Pin #	Name	Control Function	Type	0	1	PWD
Bit 7	12,13	REQASRC7	CLKREQA# Controls SRC7	RW	Does not control	Controls	0
Bit 6	16,17	REQASRC6	CLKREQA# Controls SRC6	RW	Does not control	Controls	0
Bit 5	18,19	REQASRC5	CLKREQA# Controls SRC5	RW	Does not control	Controls	0
Bit 4	22,23	REQASRC4	CLKREQA# Controls SRC4	RW	Does not control	Controls	0
Bit 3	27,28	ATIGCLK1	Output Enable These outputs cannot be controlled by CLKREQ# pins.	RW	Disabled	Enabled	1
Bit 2	30,29	ATIGCLK0		RW	Disabled	Enabled	1
Bit 1	-	Reserved	Reserved	RW	Reserved	Reserved	0
Bit 0	4	USB_48Str	48MHz Strength Control	RW	1X	2X	0

**Note: Do NOT simultaneously select CLKREQA# and CLKREQB# to control an SRC output.
Behavior of the device is undefined under these conditions.**

SMBus Table: Output Drive and ATIG Frequency Control Register

Byte 5	Pin #	Name	Control Function	Type	0	1	PWD
Bit 7	52	REF2Str	REF2 Strength Control	RW	1X	2X	0
Bit 6	-	Reserved	Reserved	RW	Reserved	Reserved	0
Bit 5	-	Reserved	Reserved	RW	Reserved	Reserved	0
Bit 4	-	SRCFS4 SSEN	Freq Select Bit 4 Spread Enable	RW	See Table 2: SRC Frequency Selection		0
Bit 3	-	SRCFS3	Freq Select Bit 3	RW			0
Bit 2	-	SRCFS2	Freq Select Bit 2	RW			0
Bit 1	-	SRCFS1	Freq Select Bit 1	RW			0
Bit 0	-	SRCFS0	Freq Select Bit 0	RW			0



SMBus Table: Device ID Register

Byte 6	Pin #	Name	Control Function	Type	0	1	PWD
Bit 7	-	DevID 7	Device ID MSB	R	-	-	0
Bit 6	-	DevID 6	Device ID 6	R	-	-	0
Bit 5	-	DevID 5	Device ID 5	R	-	-	0
Bit 4	-	DevID 4	Device ID4	R	-	-	1
Bit 3	-	DevID 3	Device ID3	R	-	-	0
Bit 2	-	DevID 2	Device ID2	R	-	-	1
Bit 1	-	DevID 1	Device ID1	R	-	-	1
Bit 0	-	DevID 0	Device ID LSB	R	-	-	0

SMBus Table: Vendor ID Register

Byte 7	Pin #	Name	Control Function	Type	0	1	PWD
Bit 7	-	RID3	Revision ID	R	-	-	X
Bit 6	-	RID2		R	-	-	X
Bit 5	-	RID1		R	-	-	X
Bit 4	-	RID0		R	-	-	X
Bit 3	-	VID3	VENDOR ID (0001 = ICS)	R	-	-	0
Bit 2	-	VID2		R	-	-	0
Bit 1	-	VID1		R	-	-	0
Bit 0	-	VID0		R	-	-	1

SMBus Table: Byte Count Register

Byte 8	Pin #	Name	Control Function	Type	0	1	PWD
Bit 7	-	BC7	Byte Count Programming b(7:0)	RW	Writing to this register will configure how many bytes will be read back, default is 9 bytes.		0
Bit 6	-	BC6		RW			0
Bit 5	-	BC5		RW			0
Bit 4	-	BC4		RW			0
Bit 3	-	BC3		RW			1
Bit 2	-	BC2		RW			0
Bit 1	-	BC1		RW			0
Bit 0	-	BC0		RW			1

SMBus Table: WD Timer Control Register

Byte 9	Pin #	Name	Control Function	Type	0	1	PWD
Bit 7	-	WDH_EN	Watchdog Hard Alarm Enable	RW	Disable	Enable	0
Bit 6	-	WDS_EN	Watchdog Soft Alarm Enable	RW	Disable	Enable	0
Bit 5	-	WD Hard Status	WD Hard Alarm Status	R	Normal	Alarm	X
Bit 4	-	WD Soft Status	WD Soft Alarm Status	R	Normal	Alarm	X
Bit 3	-	WDTCtrl	Watch Dog Time base Control	RW	290ms Base	1160ms Base	0
Bit 2	-	WD2	WD Timer Bit 2	RW	These bits represent X*290ms (or 1.16S) the watchdog timer waits		1
Bit 1	-	WD1	WD Timer Bit 1	RW			1
Bit 0	-	WD0	WD Timer Bit 0	RW			1



SMBus Table: M/N Programming & WD Safe Frequency Control Register

Byte 10	Pin #	Name	Control Function	Type	0	1	PWD
Bit 7	-	M/N_EN	CPU/SRC M/N Programming Enable	RW	Disable	Enable	0
Bit 6	-	Reserved	Reserved	RW	-	-	0
Bit 5	-	WD Safe Freq Source	WD Safe Freq Source	RW	B10b(4:0)	Latch Inputs	0
Bit 4	-	WD SF4	Watch Dog Safe Freq Programming bits	RW	Writing to these bit will configure the safe frequency as Byte0 bit (4:0).		0
Bit 3	-	WD SF3		RW			0
Bit 2	-	WD SF2		RW			0
Bit 1	-	WD SF1		RW			0
Bit 0	-	WD SF0		RW			0

SMBus Table: CPU Frequency Control Register

Byte 11	Pin #	Name	Control Function	Type	0	1	PWD
Bit 7	-	N Div8	N Divider Prog bit 8	RW	The decimal representation of M and N Divider in Byte 11 and 12 will configure the CPU VCO frequency. Default at power up = latch-in or Byte 0 Rom table. VCO Frequency =		X
Bit 6	-	N Div9	N Divider Prog bit 9	RW			X
Bit 5	-	M Div5	M Divider Programming bit (5:0)	RW			X
Bit 4	-	M Div4		RW			X
Bit 3	-	M Div3		RW			X
Bit 2	-	M Div2		RW			X
Bit 1	-	M Div1		RW			X
Bit 0	-	M Div0	RW	X			

SMBus Table: CPU Frequency Control Register

Byte 12	Pin #	Name	Control Function	Type	0	1	PWD
Bit 7	-	N Div7	N Divider Programming Byte12 bit(7:0) and Byte11 bit(7:6)	RW	The decimal representation of M and N Divider in Byte 11 and 12 will configure the CPU VCO frequency. Default at power up = latch-in or Byte 0 Rom table. VCO Frequency =		X
Bit 6	-	N Div6		RW			X
Bit 5	-	N Div5		RW			X
Bit 4	-	N Div4		RW			X
Bit 3	-	N Div3		RW			X
Bit 2	-	N Div2		RW			X
Bit 1	-	N Div1		RW			X
Bit 0	-	N Div0		RW			X

SMBus Table: CPU Spread Spectrum Control Register

Byte 13	Pin #	Name	Control Function	Type	0	1	PWD
Bit 7	-	SSP7	Spread Spectrum Programming bit(7:0)	RW	These Spread Spectrum bits in Byte 13 and 14 will program the spread percentage of CPU		X
Bit 6	-	SSP6		RW			X
Bit 5	-	SSP5		RW			X
Bit 4	-	SSP4		RW			X
Bit 3	-	SSP3		RW			X
Bit 2	-	SSP2		RW			X
Bit 1	-	SSP1		RW			X
Bit 0	-	SSP0		RW			X



SMBus Table: CPU Spread Spectrum Control Register

Byte 14	Pin #	Name	Control Function	Type	0	1	PWD
Bit 7	-	Reserved	Reserved	R	-	-	0
Bit 6	-	SSP14	Spread Spectrum Programming bit(14:8)	RW	These Spread Spectrum bits in Byte 13 and 14 will program the spread percentage of CPU		X
Bit 5	-	SSP13		RW			X
Bit 4	-	SSP12		RW			X
Bit 3	-	SSP11		RW			X
Bit 2	-	SSP10		RW			X
Bit 1	-	SSP9		RW			X
Bit 0	-	SSP8		RW			X

SMBus Table: SRC Frequency Control Register

Byte 15	Pin #	Name	Control Function	Type	0	1	PWD
Bit 7	-	N Div8	N Divider Prog bit 8	RW	The decimal representation of M and N Divier in Byte 15 and 16 will configure the SRC VCO frequency. Default at power up = latch-in or Byte 0 Rom table. VCO Frequency		X
Bit 6	-	N Div9	N Divider Prog bit 9	RW			X
Bit 5	-	M Div5	M Divider Programming bits	RW			X
Bit 4	-	M Div4		RW			X
Bit 3	-	M Div3		RW			X
Bit 2	-	M Div2		RW			X
Bit 1	-	M Div1		RW			X
Bit 0	-	M Div0		RW			X

SMBus Table: SRC Frequency Control Register

Byte 16	Pin #	Name	Control Function	Type	0	1	PWD
Bit 7	-	N Div7	N Divider Programming b(7:0)	RW	The decimal representation of M and N Divier in Byte 15 and 16 will configure the SRC VCO frequency. Default at power up = latch-in or Byte 0 Rom table. VCO Frequency =		X
Bit 6	-	N Div6		RW			X
Bit 5	-	N Div5		RW			X
Bit 4	-	N Div4		RW			X
Bit 3	-	N Div3		RW			X
Bit 2	-	N Div2		RW			X
Bit 1	-	N Div1		RW			X
Bit 0	-	N Div0		RW			X

SMBus Table: SRC Spread Spectrum Control Register

Byte 17	Pin #	Name	Control Function	Type	0	1	PWD
Bit 7	-	SSP7	Spread Spectrum Programming b(7:0)	RW	These Spread Spectrum bits in Byte 17 and 18 will program the spread percentage of SRC		X
Bit 6	-	SSP6		RW			X
Bit 5	-	SSP5		RW			X
Bit 4	-	SSP4		RW			X
Bit 3	-	SSP3		RW			X
Bit 2	-	SSP2		RW			X
Bit 1	-	SSP1		RW			X
Bit 0	-	SSP0		RW			X

**SMBus Table: SRC Spread Spectrum Control Register**

Byte 18	Pin #	Name	Control Function	Type	0	1	PWD
Bit 7	-	Reserved	Reserved	R	-	-	0
Bit 6	-	SSP14	Spread Spectrum Programming b(14:8)	RW	These Spread Spectrum bits in Byte 17 and 18 will program the spread percentage of SRC		X
Bit 5	-	SSP13		RW			X
Bit 4	-	SSP12		RW			X
Bit 3	-	SSP11		RW			X
Bit 2	-	SSP10		RW			X
Bit 1	-	SSP9		RW			X
Bit 0	-	SSP8		RW			X

SMBus Table: Programmable Output Divider Register

Byte 19	Pin #	Name	Control Function	Type	0	1	PWD
Bit 7	-	CPUDiv3	CPU Divider Ratio Programming Bits	RW	See Table 3: CPU Divider Ratios		X
Bit 6	-	CPUDiv2		RW			X
Bit 5	-	CPUDiv1		RW			X
Bit 4	-	CPUDiv0		RW			X
Bit 3	-	HTTDiv3	HTT Divider Ratio Programming Bits (PCI divider is always 2x the HTT divider or 1/2 freq.)	RW	See Table 4: HTT Divider Ratios		X
Bit 2	-	HTTDiv2		RW			X
Bit 1	-	HTTDiv1		RW			X
Bit 0	-	HTTDiv0		RW			X

SMBus Table: Programmable Output Divider Register

Byte 20	Pin #	Name	Control Function	Type	0	1	PWD
Bit 7	-	SRC_Div3	SRC_Divider Ratio Programming Bits	RW	See Table 5: SRC and ATIG Divider Ratios		X
Bit 6	-	SRC_Div2		RW			X
Bit 5	-	SRC_Div1		RW			X
Bit 4	-	SRC_Div0		RW			X
Bit 3	-	ATIG_Div3	ATIG_Divider Ratio Programming Bits	RW			X
Bit 2	-	ATIG_Div2		RW			X
Bit 1	-	ATIG_Div1		RW			X
Bit 0	-	ATIG_Div0		RW			X



Absolute Maximum Ratings

Supply Voltage 3.8V
 Logic Inputs GND –0.5 V to $V_{DD} + 3.8$ V
 Ambient Operating Temperature 0°C to +70°C
 Storage Temperature –65°C to +150°C
 ESD Protection Input ESD protection using human body model > 1KV

Stresses above those listed under *Absolute Maximum Ratings* may cause permanent damage to the device. These ratings are stress specifications only and functional operation of the device at these or any other conditions above those listed in the operational sections of the specifications is not implied. Exposure to absolute maximum rating conditions for extended periods may affect product reliability.

Electrical Characteristics - Input/Supply/Common Output Parameters

$T_A = 0 - 70^\circ\text{C}$; Supply Voltage $V_{DD} = 3.3$ V +/-5%

PARAMETER	SYMBOL	CONDITIONS	MIN	TYP	MAX	UNITS	NOTES
Input High Voltage	V_{IH}	3.3 V +/-5%	2		$V_{DD} + 0.3$	V	1
Input Low Voltage	V_{IL}	3.3 V +/-5%	$V_{SS} - 0.3$		0.8	V	1
Input High Current	I_{IH}	$V_{IN} = V_{DD}$	-5		5	uA	1
Input Low Current	I_{IL1}	$V_{IN} = 0$ V; Inputs with no pull-up resistors	-5			uA	1
	I_{IL2}	$V_{IN} = 0$ V; Inputs with pull-up resistors	-200			uA	1
Operating Current	$I_{DD3,30P}$	all outputs driven			300	mA	
Input Frequency ³	F_i	$V_{DD} = 3.3$ V		14.31818		MHz	3
Pin Inductance ¹	L_{pin}				7	nH	1
Input Capacitance ¹	C_{IN}	Logic Inputs			5	pF	1
	C_{OUT}	Output pin capacitance			6	pF	1
	C_{INX}	X1 & X2 pins			5	pF	1
Clk Stabilization ^{1,2}	T_{STAB}	From V_{DD} Power-Up or de-assertion of PD# to 1st clock			3	ms	1,2
Modulation Frequency		Triangular Modulation	30		33	kHz	1
SMBus Voltage	V_{DD}		2.7		5.5	V	1
Low-level Output Voltage	V_{OL}	@ I_{PULLUP}			0.4	V	1
Current sinking at $V_{OL} = 0.4$ V	I_{PULLUP}		4			mA	1
SCLK/SDATA Clock/Data Rise Time ³	T_{RI2C}	(Max $V_{IL} - 0.15$) to (Min $V_{IH} + 0.15$)			1000	ns	1
SCLK/SDATA Clock/Data Fall Time ³	T_{FI2C}	(Min $V_{IH} + 0.15$) to (Max $V_{IL} - 0.15$)			300	ns	1

¹Guaranteed by design and characterization, not 100% tested in production.

²See timing diagrams for timing requirements.

³ Input frequency should be measured at the REFOUT pin and tuned to ideal 14.31818MHz to meet ppm frequency accuracy on PLL outputs.



Electrical Characteristics - K8 Push Pull Differential Pair

$T_A = 0 - 70^\circ\text{C}$; $V_{DD} = 3.3\text{ V} \pm 5\%$; $C_L = \text{AMD64 Processor Test Load}$

PARAMETER	SYMBOL	CONDITIONS	MIN	TYP	MAX	UNITS	NOTES
Rising Edge Rate	$\delta V/\delta t$	Measured at the AMD64 processor's test load. 0 V +/- 400 mV (differential measurement)	2		10	V/ns	1
Falling Edge Rate	$\delta V/\delta t$		2		10	V/ns	1
Differential Voltage	V_{DIFF}	Measured at the AMD64 processor's test load. (single-ended measurement)	0.4	1.25	2.3	V	1
Change in V_{DIFF_DC} Magnitude	ΔV_{DIFF}		-150		150	mV	1
Common Mode Voltage	V_{CM}		1.05	1.25	1.45	V	1
Change in Common Mode Voltage	ΔV_{CM}		-200		200	mV	1
Jitter, Cycle to cycle	$t_{jyc-cyc}$	Measurement from differential waveform. Maximum difference of cycle time between 2 adjacent cycles.	0	100	200	ps	1
Jitter, Accumulated	t_{ja}	Measured using the JIT2 software package with a Tek 7404 scope. TIE (Time Interval Error) measurement technique: Sample resolution = 50 ps, Sample Duration = 10 us	-1000		1000		1,2,3
Duty Cycle	d_{t3}	Measurement from differential waveform	45		53	%	1
Output Impedance	R_{ON}	Average value during switching transition. Used for determining series termination value.	15	35	55	Ω	1
Group Skew	$t_{src-skew}$	Measurement from differential waveform			250	ps	1

¹Guaranteed by design and characterization, not 100% tested in production.

²All accumulated jitter specifications are guaranteed assuming that REF is at 14.31818MHz

³Spread Spectrum is off



Electrical Characteristics - SRC 0.7V Current Mode Differential Pair

T_A = 0 - 70°C; V_{DD} = 3.3 V +/-5%; C_L =2pF, R_S=33.2Ω, R_P=49.9Ω, I_{REF} = 475Ω

PARAMETER	SYMBOL	CONDITIONS	MIN	TYP	MAX	UNITS	NOTES
Current Source Output Impedance	Z _o	V _O = V _x	3000			Ω	1
Voltage High	V _H High	Statistical measurement on single ended signal using oscilloscope math function.	660		850	mV	1,3
Voltage Low	V _L Low		-150		150		1,3
Max Voltage	V _{ovs}	Measurement on single ended signal using absolute value.			1150	mV	1
Min Voltage	V _{uds}		-300				1
Crossing Voltage (abs)	V _{cross(abs)}		250	350	550	mV	1
Crossing Voltage (var)	d-V _{cross}	Variation of crossing over all edges		12	140	mV	1
Long Accuracy	ppm	see T _{period} min-max values	-300		300	ppm	1,2
Average period	T _{period}	75.00 MHz nominal	8.5684	8.5714	8.5744	ns	2
		75.00 MHz spread	8.5684		8.6244	ns	2
		100.00 MHz nominal	9.9970	10.0000	10.0030	ns	2
		100.00 MHz spread	9.9970		10.0530	ns	2
		116.67 MHz nominal	13.3303	13.3333	13.3363	ns	2
		116.67 MHz spread	13.3303		13.3863	ns	2
		133.33 MHz nominal	7.4972	7.5002	7.5032	ns	2
		133.33 MHz spread	7.4972		7.5532	ns	2
Absolute min period	T _{absmin}	@ 100.00MHz nominal/spread	9.8720			ns	1,2
Rise Time	t _r	V _{OL} = 0.175V, V _{OH} = 0.525V	175		700	ps	1
Fall Time	t _f	V _{OH} = 0.525V V _{OL} = 0.175V	175		700	ps	1
Rise Time Variation	d-t _r			30	125	ps	1
Fall Time Variation	d-t _f			30	125	ps	1
Duty Cycle	d ₁₃	Measurement from differential waveform	45		55	%	1
Group Skew	t _{src-skew}	Measurement from differential waveform			250	ps	
Jitter, Cycle to cycle	t _{j_{cyc-cyc}}	Measurement from differential waveform			100	ps	1

¹Guaranteed by design and characterization, not 100% tested in production.

²All Long Term Accuracy and Clock Period specifications are guaranteed assuming that REF is at 14.31818MHz

³I_{REF} = V_{DD}/(3xR_R). For R_R = 475Ω (1%), I_{REF} = 2.32mA. I_{OH} = 6 x I_{REF} and V_{OH} = 0.7V @ Z_O=50Ω.



Electrical Characteristics - PCI33, HTT66 Clocks

$T_A = 0 - 70^\circ\text{C}$; $V_{DD} = 3.3\text{V} \pm 5\%$; $C_L = 30\text{ pF}$ (unless otherwise specified)

PARAMETER	SYMBOL	CONDITIONS	MIN	TYP	MAX	UNITS	Notes
Long Accuracy	ppm	see Tperiod min-max values	-300		300	ppm	1,2
PCI33 Clock period	T_{period}	33.33MHz output nominal	29.9910		30.0090	ns	2
		33.33MHz output spread	29.9910		30.1598	ns	2
HTT66 Clock period	T_{period}	66.67MHz output nominal	14.9955		15.0045	ns	2
		66.67MHz output spread	14.9955		15.0799	ns	2
Output High Voltage	V_{OH}	$I_{OH} = -1\text{ mA}$	2.4			V	1
Output Low Voltage	V_{OL}	$I_{OL} = 1\text{ mA}$			0.55	V	1
Output High Current	I_{OH}	$V_{OH} @ \text{MIN} = 1.0\text{ V}$	-33		-46	mA	1
		$V_{OH} @ \text{MAX} = 3.135\text{ V}$	-50		-80	mA	1
Output Low Current	I_{OL}	$V_{OL} @ \text{MIN} = 1.95\text{ V}$	47		64	mA	1
		$V_{OL} @ \text{MAX} = 0.4\text{ V}$	58		91	mA	1
Edge Rate	$\delta V / \delta t$	Rising edge rate	1		4	V/ns	1
Edge Rate	$\delta V / \delta t$	Falling edge rate	1		4	V/ns	1
Rise Time	t_{r1}	$V_{OL} = 0.4\text{ V}, V_{OH} = 2.4\text{ V}$	0.5		2	ns	1
Fall Time	t_{f1}	$V_{OH} = 2.4\text{ V}, V_{OL} = 0.4\text{ V}$	0.5		2	ns	1
Duty Cycle	d_{t1}	$V_T = 1.5\text{ V}$	45		55	%	1
Skew	t_{sk1}	$V_T = 1.5\text{ V}$			500	ps	1
Jitter, Cycle to cycle	$t_{j\text{cyc-cyc}}$	$V_T = 1.5\text{ V}$			180	ps	1

¹Guaranteed by design and characterization, not 100% tested in production.

²All Long Term Accuracy and Clock Period specifications are guaranteed with the assumption that REF is at 14.31818MHz



Electrical Characteristics - 48MHz, USB

$T_A = 0 - 70^\circ\text{C}$; $V_{DD} = 3.3\text{ V} \pm 5\%$; $C_L = 10\text{-}20\text{ pF}$ (unless otherwise specified)

PARAMETER	SYMBOL	CONDITIONS	MIN	TYP	MAX	UNITS	Notes
Long Accuracy	ppm	see Tperiod min-max values	-200		200	ppm	1,2
Clock period	T_{period}	48.00MHz output nominal	20.8257		20.8340	ns	2
Output High Voltage	V_{OH}	$I_{OH} = -1\text{ mA}$	2.4			V	1
Output Low Voltage	V_{OL}	$I_{OL} = 1\text{ mA}$			0.55	V	1
Output High Current	I_{OH}	$V_{OH} @ \text{MIN} = 1.0\text{ V}$	-33		-46	mA	1
		$V_{OH} @ \text{MAX} = 3.135\text{ V}$	-50		-80	mA	1
Output Low Current	I_{OL}	$V_{OL} @ \text{MIN} = 1.95\text{ V}$	47		64	mA	1
		$V_{OL} @ \text{MAX} = 0.4\text{ V}$	58		91	mA	1
Edge Rate	$\delta V/\delta t$	Rising edge rate	1		2	V/ns	1
Edge Rate	$\delta V/\delta t$	Falling edge rate	1		2	V/ns	1
Rise Time	t_{r1}	$V_{OL} = 0.4\text{ V}, V_{OH} = 2.4\text{ V}$	1	1.43	2	ns	1
Fall Time	t_{f1}	$V_{OH} = 2.4\text{ V}, V_{OL} = 0.4\text{ V}$	1	1.33	2	ns	1
Duty Cycle	d_{t1}	$V_T = 1.5\text{ V}$	45	48	55	%	1
Jitter, Cycle to cycle	$t_{j\text{cyc-cyc}}$	$V_T = 1.5\text{ V}$			180	ps	1

¹Guaranteed by design and characterization, not 100% tested in production.

²All Long Term Accuracy and Clock Period specifications are guaranteed with the assumption that REF is at 14.31818MHz



Electrical Characteristics - REF-14.318MHz

$T_A = 0 - 70^\circ\text{C}$; $V_{DD} = 3.3\text{ V} \pm 5\%$; $C_L = 10\text{-}20\text{ pF}$ (unless otherwise specified)

PARAMETER	SYMBOL	CONDITIONS	MIN	TYP	MAX	UNITS	Notes
Long Accuracy	ppm	see Tperiod min-max values	-300		300	ppm	1
Clock period	T_{period}	14.318MHz output nominal	69.8270		69.8550	ns	2
Output High Voltage	V_{OH}	$I_{OH} = -1\text{ mA}$	2.4			V	1
Output Low Voltage	V_{OL}	$I_{OL} = 1\text{ mA}$			0.4	V	1
Output High Current	I_{OH}	$V_{OH} @ \text{MIN} = 1.0\text{ V}$	-29		-41	mA	1
		$V_{OH} @ \text{MAX} = 3.135\text{ V}$	-45		-71		
Output Low Current	I_{OL}	$V_{OL} @ \text{MIN} = 1.95\text{ V}$	39		54	mA	1
		$V_{OL} @ \text{MAX} = 0.4\text{ V}$	49		77		
Edge Rate	$\delta V/\delta t$	Rising edge rate	1		4	V/ns	1
Edge Rate	$\delta V/\delta t$	Falling edge rate	1		4	V/ns	1
Rise Time	t_{r1}	$V_{OL} = 0.4\text{ V}, V_{OH} = 2.4\text{ V}$	1		2	ns	1
Fall Time	t_{f1}	$V_{OH} = 2.4\text{ V}, V_{OL} = 0.4\text{ V}$	1		2	ns	1
Skew	t_{sk1}	$V_T = 1.5\text{ V}$			500	ps	1
Duty Cycle	d_{t1}	$V_T = 1.5\text{ V}$	45		55	%	1
Jitter, Cycle to cycle	$t_{jyc-cyc}$	$V_T = 1.5\text{ V}$			700	ps	1

¹Guaranteed by design and characterization, not 100% tested in production.

²All Long Term Accuracy and Clock Period specifications are guaranteed with the assumption that REF is at 14.31818MHz

SRC Reference Clock				
Common Recommendations for Differential Routing		Dimension or Value	Unit	Figure
L1 length, Route as non	-coupled 50 ohm trace.	0.5 max	inch	2, 3
L2 length, Route as non	-coupled 50 ohm trace.	0.2 max	inch	2, 3
L3 length, Route as non	-coupled 50 ohm trace.	0.2 max	inch	2, 3
Rs		33	ohm	2, 3
Rt		49.9	ohm	2, 3

Down Device Differential Routing		Dimension or Value	Unit	Figure
L4 length, Route as coupled differential trace.	microstrip 100 ohm	2 min to 16 max	inch	2
L4 length, Route as coupled differential trace.	stripline 100 ohm	1.8 min to 14.4 max	inch	2

Differential Routing to PCI Express Connector		Dimension or Value	Unit	Figure
L4 length, Route as coupled differential trace.	microstrip 100 ohm	0.25 to 14 max	inch	3
L4 length, Route as coupled differential trace.	stripline 100 ohm	0.225 min to 12.6 max	inch	3

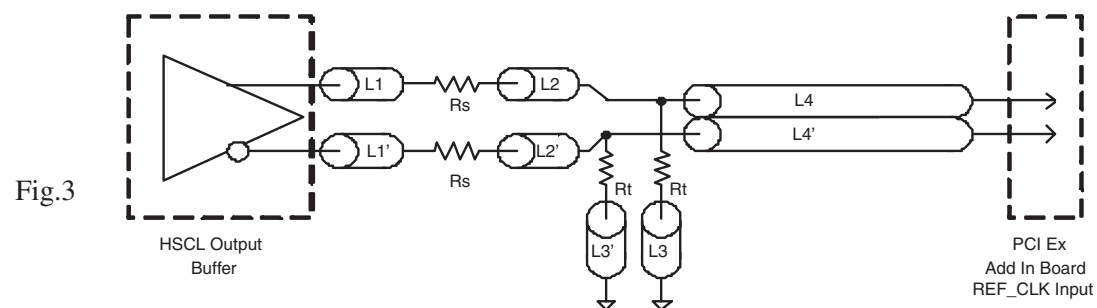
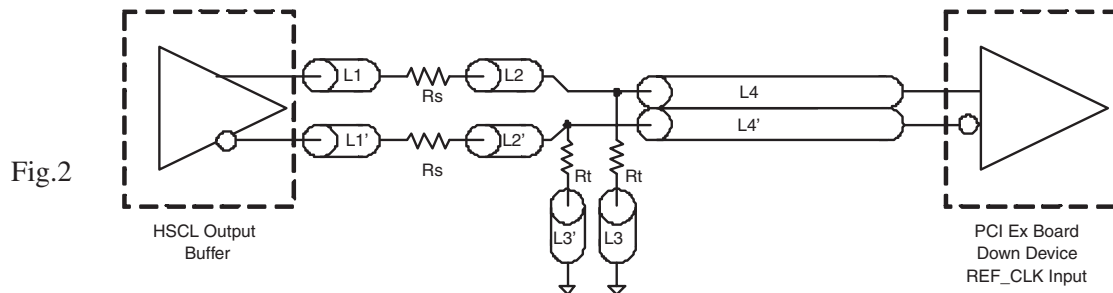
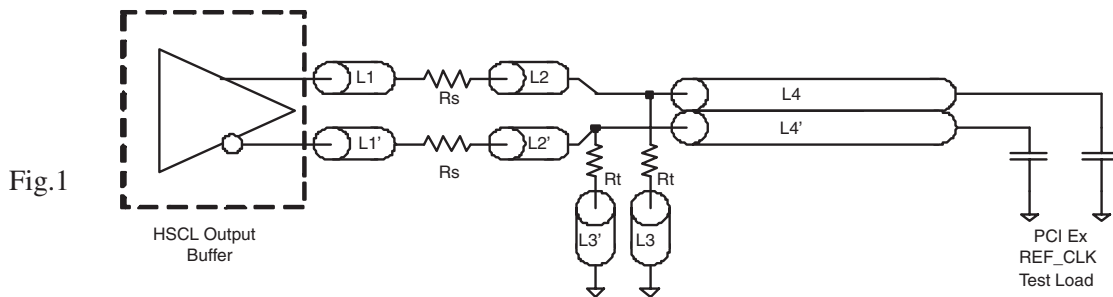



Shared Pin Operation - Input/Output Pins

The I/O pins designated by (input/output) on the **ICS951416** serve as dual signal functions to the device. During initial power-up, they act as input pins. The logic level (voltage) that is present on these pins at this time is read and stored into a 5-bit internal data latch. At the end of Power-On reset, (see AC characteristics for timing values), the device changes the mode of operations for these pins to an output function. In this mode the pins produce the specified buffered clocks to external loads.

To program (load) the internal configuration register for these pins, a resistor is connected to either the VDD (logic 1) power supply or the GND (logic 0) voltage potential. A 10 Kilohm (10K) resistor is used to provide both the solid CMOS programming voltage needed during the power-up programming period and to provide an insignificant load on the output clock during the subsequent operating period.

Figure 1 shows a means of implementing this function when a switch or 2 pin header is used. With no jumper is installed the pin will be pulled high. With the jumper in place the pin will be pulled low. If programmability is not necessary, than only a single resistor is necessary. The programming resistors should be located close to the series termination resistor to minimize the current loop area. It is more important to locate the series termination resistor close to the driver than the programming resistor.

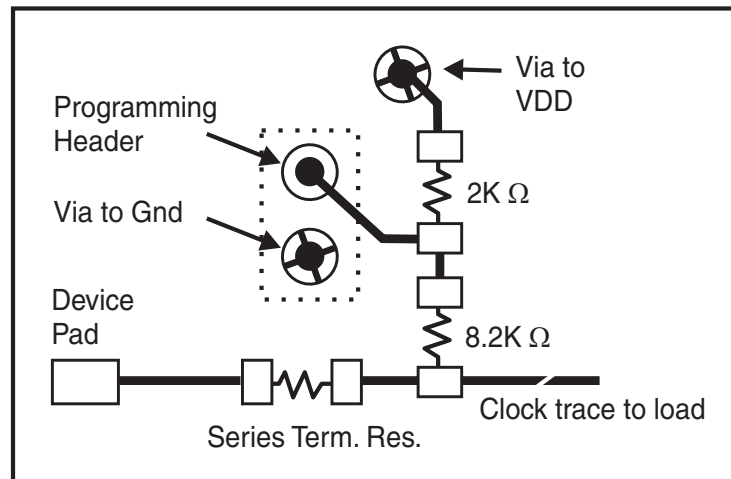
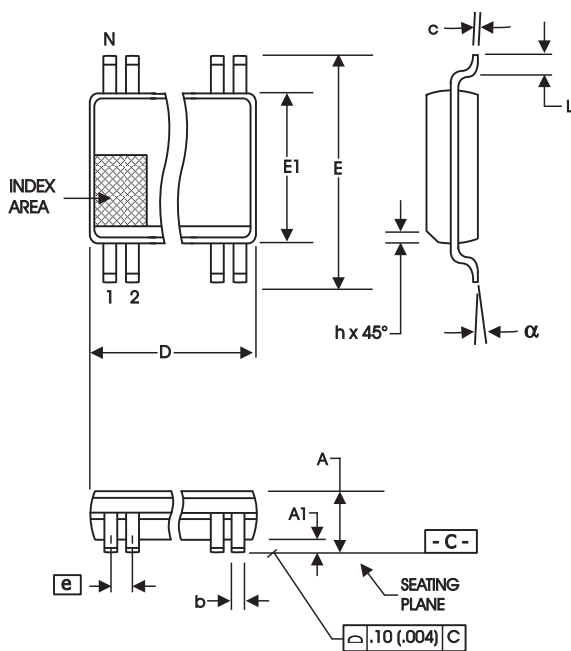

Fig. 1



56-Lead, 300 mil Body, 25 mil, SSOP

SYMBOL	In Millimeters COMMON DIMENSIONS		In Inches COMMON DIMENSIONS	
	MIN	MAX	MIN	MAX
A	2.41	2.80	.095	.110
A1	0.20	0.40	.008	.016
b	0.20	0.34	.008	.0135
c	0.13	0.25	.005	.010
D	SEE VARIATIONS		SEE VARIATIONS	
E	10.03	10.68	.395	.420
E1	7.40	7.60	.291	.299
e	0.635 BASIC		0.025 BASIC	
h	0.38	0.64	.015	.025
L	0.50	1.02	.020	.040
N	SEE VARIATIONS		SEE VARIATIONS	
a	0°	8°	0°	8°

VARIATIONS

N	D mm.		D (inch)	
	MIN	MAX	MIN	MAX
56	18.31	18.55	.720	.730

Reference Doc.: JEDEC Publication 95, MO-118

10-0034

Ordering Information

ICS951416yFLFT

Example:

ICS XXXX y F - LFT

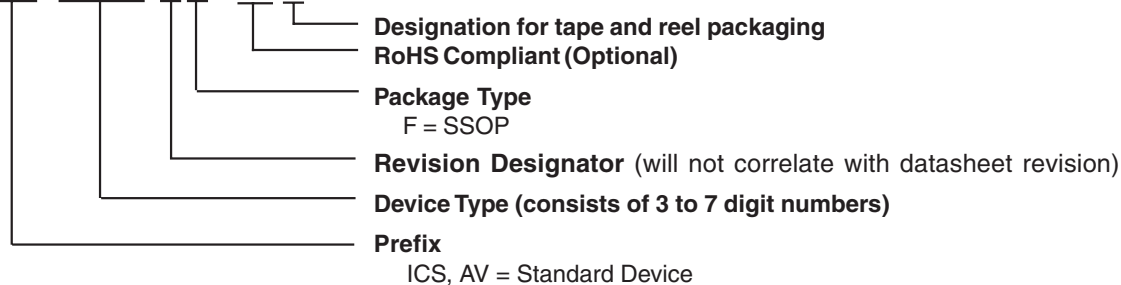

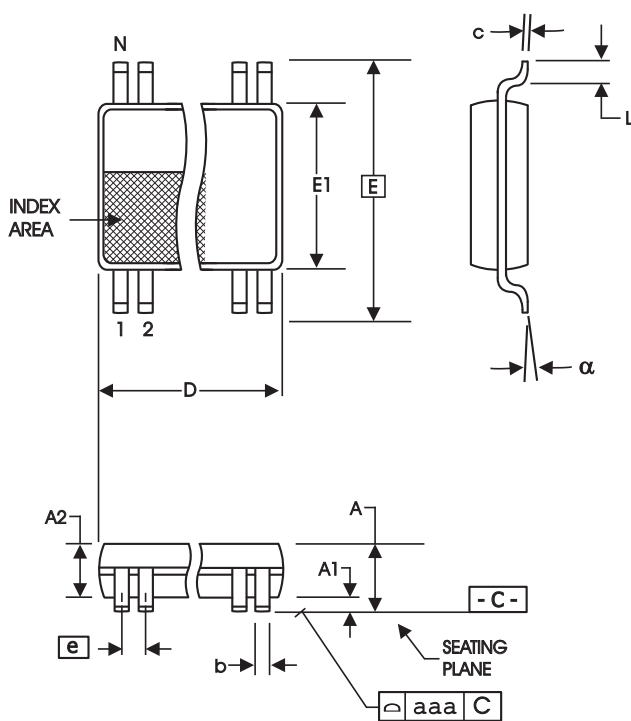

56-Lead 6.10 mm. Body, 0.50 mm. Pitch TSSOP
(240 mil) (20 mil)

SYMBOL	In Millimeters		In Inches	
	COMMON DIMENSIONS	COMMON DIMENSIONS	COMMON DIMENSIONS	COMMON DIMENSIONS
A	--	1.20	--	.047
A1	0.05	0.15	.002	.006
A2	0.80	1.05	.032	.041
b	0.17	0.27	.007	.011
c	0.09	0.20	.0035	.008
D	SEE VARIATIONS		SEE VARIATIONS	
E	8.10 BASIC		0.319 BASIC	
E1	6.00	6.20	.236	.244
e	0.50 BASIC		0.020 BASIC	
L	0.45	0.75	.018	.030
N	SEE VARIATIONS		SEE VARIATIONS	
a	0°	8°	0°	8°
aaa	--	0.10	--	.004

VARIATIONS

N	D mm.		D (inch)	
	MIN	MAX	MIN	MAX
56	13.90	14.10	.547	.555

Reference Doc.: JEDEC Publication 95, MO-153

10-0039

Ordering Information

ICS951416yGLFT

Example:

ICS XXXX y G - LFT

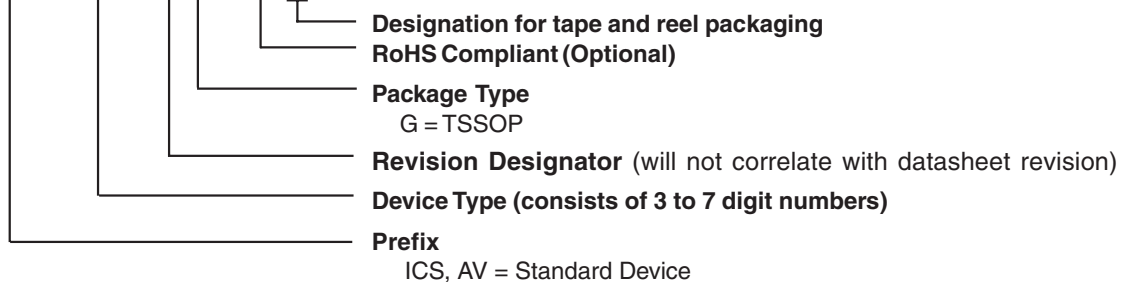



Revision History

Rev.	Issue Date	Description	Page #
D	11/11/2004	Changes Pull Down Symbol from ~ to **	1,2,3
E	12/8/2004	Update CPU and SRC frequency selection table.	6,7
F	4/22/2005	1. Updated the Electrical Characteristics for HTT. 2. Updated Ordering Information from "Lead Free" to "Annealed Lead Free".	18,23-24
G	4/29/2005	Updated the Electrical Characteristics for REF and USB.	19, 20
H	5/26/2005	1. Changed Byte 10 bit 7 to "CPU/SRC M/N Programming Bit." 2. Updated LF Ordering Information to "RoHS Compliant"	12, 23-24

Looking for pricing, stock, or lifecycle information?

Click below to explore more details on WIN SOURCE:

- [⊖ View ICS951416AFLF on WIN SOURCE](#)
- [⊖ IDT, Integrated Device Technology Inc Information](#)

Optimize Your Supply Chain with WIN SOURCE Solutions

- ✓ Global Sourcing Solution
- ✓ Obsolete Management
- ✓ Cost Control Management
- ✓ Shortage Management
- ✓ Alternative Solution
- ✓ Excess Inventory Management