

Product Overview

The QPQ1282 is a high performance Bulk Acoustic Wave (BAW) Duplexer designed for Band 1 uplink/downlink applications.

The QPQ1282 provides low insertion loss and high rejection making it an ideal choice for Small Cells. This duplexer is housed in a compact, RoHs compliant 2.00 mm x 2.50 mm x 0.91 surface mount package (SMP).

The QPQ1282 is part of Qorvo's extensive portfolio of RF BAW and SAW filters.



9 Pad 2.00 mm x 2.50 mm x 0.91 mm SMP

Functional Block Diagram

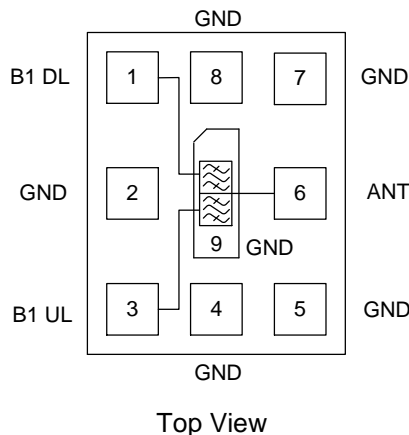

Pin Configuration

Pin No.	Label
1	Band 1 Downlink
2, 4, 5, 7, 8, 9	Ground
3	Band 1 Uplink
6	Antenna Port

Key Features

- 60 MHz Bandwidth – Band 1 UL
- 60 MHz Bandwidth – Band 1 DL
- High Attenuation
- Low Loss
- No External Matching Required
- Single Input, Single Output Operation
- Small Size: 2.00 mm x 2.50 mm x 0.91 mm
- Surface Mount Package (SMP)
- RoHS Compliant, Pb-Free

Applications

- Band 1
- Base Station Infrastructure
- Small Cells
- Repeaters
- Routers
- LTE Dongles
- General Purpose Wireless

Ordering Information

Part No.	Description
QPQ1282SR	100 pieces on a 7" reel
QPQ1282TR7	2,500 pieces on a 7" reel (standard)
QPQ1282EVB	Evaluation Board

Absolute Maximum Ratings

Parameter	Rating
Storage Temperature	-40 to +125°C
Operation Temperature	-40 to +85 °C

Life Test

Conditions	Rating
+30 dBm DL, +85°C, FD-LTE, 5MHz 16QAM, PAR = 8dB ⁽¹⁾	> 230,000 hours
+23 dBm UL, +85°C, CW ⁽²⁾	> 245,000 hours

Notes:

1. Power applied to Pin 1.
2. Power applied to Pin 6.

Electrical Specifications ^(1, 2) – Band 1 Uplink

Parameter ⁽³⁾	Conditions	Min	Typ ⁽⁴⁾	Max	Units
Center Frequency		–	1950	–	MHz
Max Insertion Loss	1920 – 1980 MHz (-40 to +85 °C)	–	2.0	3.8	dB
Average Insertion Loss	1920 – 1925 MHz (-40 to +85 °C)	–	–	3.0	dB
	1925 – 1975 MHz (-40 to +85 °C) (5 MHz sliding Window)	–	–	2.4	dB
	1975 – 1980 MHz (-40 to +85 °C)	–	–	2.7	dB
Lower Band edge ⁽⁵⁾ Upper Band edge ⁽⁵⁾	3.5dB	– 1980	– –	1920 –	MHz
Amplitude Ripple ⁽⁶⁾	1920– 1980 MHz	–	1.5	1.6	dB p-p
	1920 – 1980 MHz (-40 to +85 °C)	–	1.5	2.2	dB p-p
Group Delay Variation	1920 – 1980 MHz	–	–	40	ns
	1920 – 1980 MHz (5 MHz sliding Window)	–	–	20	ns
EVM ⁽⁸⁾	1920 – 1980 MHz (5 MHz sliding Window)	–	0.8	–	%
Input VSWR	1920 – 1980 MHz	–	–	2.1:1	
Output VSWR		–	–	2.2:1	
Attenuation ⁽⁵⁾	0.9 – 1880 MHz	37	41.6	–	dB
	1880 – 1900 MHz	13	26.9	–	
	2000 – 2010 MHz	13	35.4	–	
	2010 – 2110 MHz	27	50.6	–	
	2110 – 2285 MHz	46.5	49.1	–	
	2285 – 2485 MHz	46	49.2	–	
	2485 – 2690 MHz	43.5	45.4	–	
	2690 – 3400 MHz	22	35.4	–	
	3400 – 3700 MHz	22	24.0	–	
3700 – 3800 MHz	20	22.0	–		
3800 – 5850 MHz	13.8	18.5	–		
Source/Load Impedance ⁽⁷⁾	Single-ended	–	50	–	Ω

Notes:

Test conditions unless otherwise noted: Temp= +25°C

1. All specifications are based on the Qorvo schematic for the main reference design.
2. The Specifications are guaranteed by design and are not tested in the final production test.
3. Electrical margin has been built into the design to account for the variations due to temperature drift and manufacturing tolerances.
4. Typical values are based on average measurements of 12 devices at room temperature.
5. Relative to zero dB.
6. This is defined as the worst difference between a peak and adjacent valley within defined frequency points.
7. This is the optimum impedance in order to achieve the performance shown.
8. Test per 3GPP TS25.141 V8.5

Electrical Specifications ^(1, 2) – Band 1 Downlink

Parameter ⁽³⁾	Conditions	Min	Typ ⁽⁴⁾	Max	Units
Center Frequency		–	2140	–	MHz
Max Insertion Loss	2110 – 2170 MHz (-40 to +85 °C)	–	2.0	3.2	dB
Average Insertion Loss	2110 – 2115 MHz (-40 to +85 °C)	–	–	2.5	dB
	2115 – 2165 MHz (-40 to +85 °C) (5 MHz sliding Window)	–	–	2.4	dB
	2165 – 2170 MHz (-40 to +85 °C)	–	–	2.7	dB
Lower Band edge ⁽⁵⁾	3.5dB	–	–	2110	MHz
Upper Band edge ⁽⁵⁾		2170	–	–	
Amplitude Ripple ⁽⁶⁾	2110–2170 MHz @ 25 °C	–	1.0	1.2	dB p-p
	2110–2170 MHz @ -40 to +85 °C	–	1.0	1.8	dB p-p
Group Delay Variation	2110–2170 MHz	–	–	40	ns
	2110–2170 MHz (5 MHz Sliding Window)	–	–	20	ns
EVM ⁽⁸⁾	2110–2170 MHz (5 MHz Sliding Window)	–	0.8	–	%
Input VSWR	2110 – 2170 MHz	–	–	2.1:1	
Output VSWR		–	–	2.2:1	
Attenuation ⁽⁵⁾	0.9 – 1920 MHz	37	40.3	–	dB
	1920 – 1980 MHz	48	50.0	–	
	1980 – 2025 MHz	27	39.3	–	
	2025 – 2070 MHz	17	31.8	–	
	2210 – 2300 MHz	17	51.1	–	
	2300 – 2690 MHz	44	46.2	–	
	2690 – 3400 MHz	27	35.9	–	
	3400 – 4200 MHz	17	33.7	–	
	4200 – 4400 MHz	32	33.6	–	
	5150 – 5850 MHz	15	18.5	–	
Isolation S32	1920—1980Mhz	50	–	–	dB
	2110—2170Mhz	49	–	–	dB
Source/Load Impedance ⁽⁷⁾	Single-ended	–	50	–	Ω

Notes:

Test conditions unless otherwise noted: Temp= +25°C

1. All specifications are based on the Qorvo schematic for the main reference design.
2. The Specifications are guaranteed by design and are not tested in the final production test.
3. Electrical margin has been built into the design to account for the variations due to temperature drift and manufacturing tolerances.
4. Typical values are based on average measurements of 12 devices at room temperature.
5. Relative to zero dB.
6. This is defined as the worst difference between a peak and adjacent valley within defined frequency points.
7. This is the optimum impedance in order to achieve the performance shown.
8. Test per 3GPP TS25.141 V8.5

QPQ1282EVB Evaluation Board

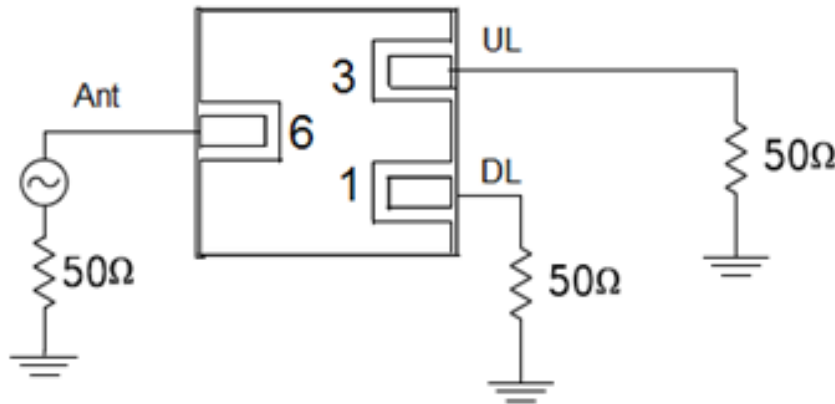
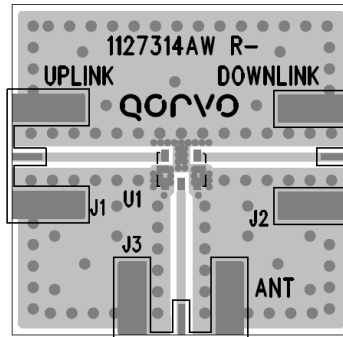

Notes:

1. Top, middle & bottom layers: 1/2 oz copper, Substrates: FR4 dielectric, 0.062" thick, Finish plating: Nickel: 3-8 μm thick, Gold: 0.03-0.2 μm thick, Hole plating: Copper min 0.0008 μm thick

Bill of Material – QPQ1282EVB

Reference Des.	Value	Description	Manuf.	Part Number
U1	n/a	QPQ1282	Qorvo	QPQ1282
SMA	n/a	SMA connector	Amphenol	901-100-44-6RFX
PCB	n/a	3-Layer	Multiple	1127314AW

Performance Plots Band 1 Uplink

Test conditions unless otherwise noted: Temp= +25°C

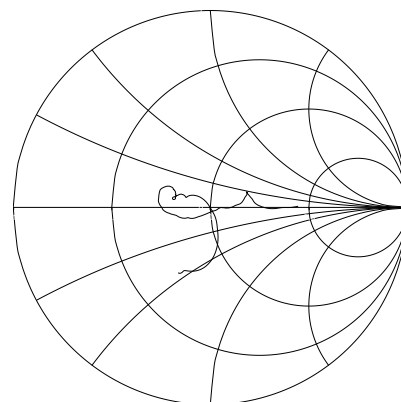
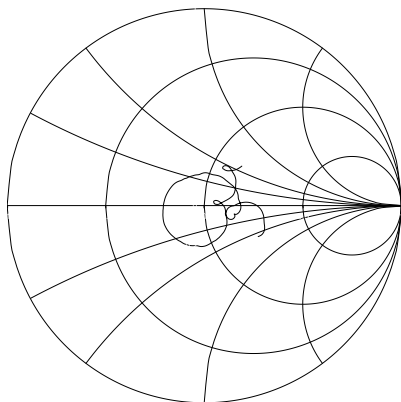
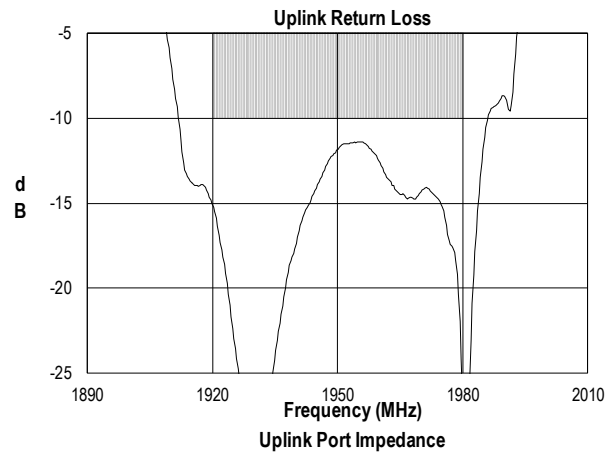
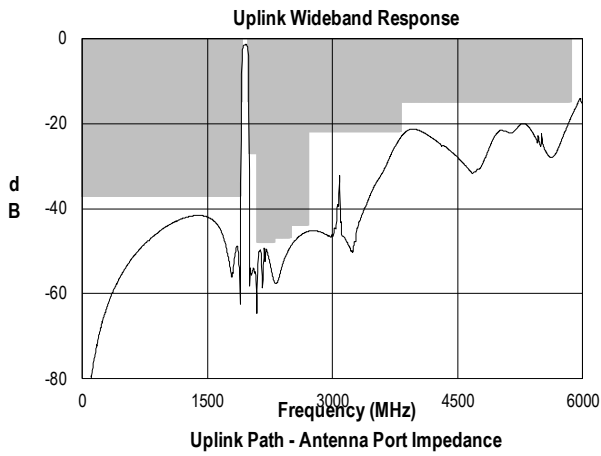
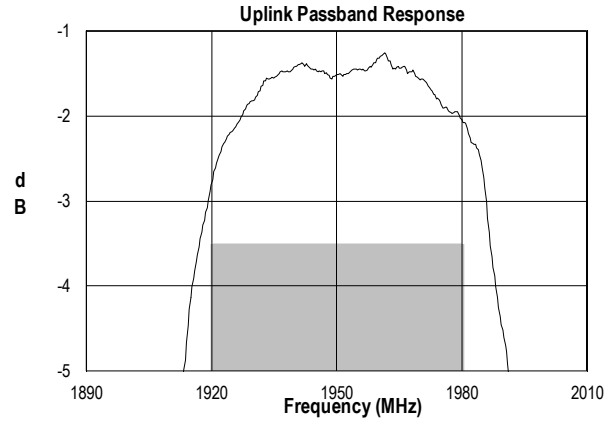
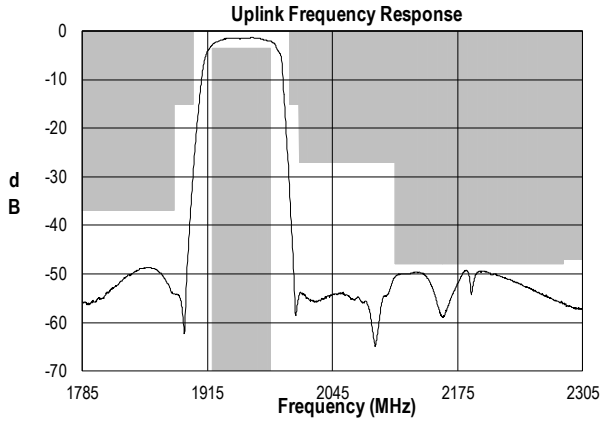

Performance Plots Band 1 Downlink

Test conditions unless otherwise noted: Temp= +25°C

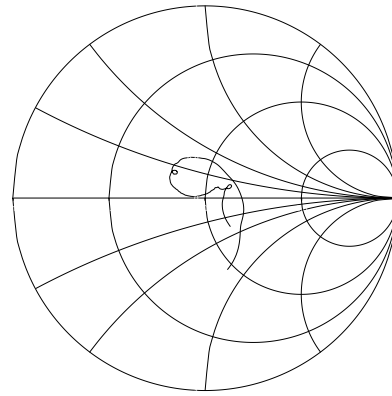
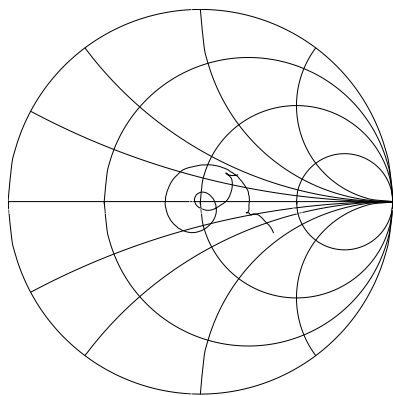
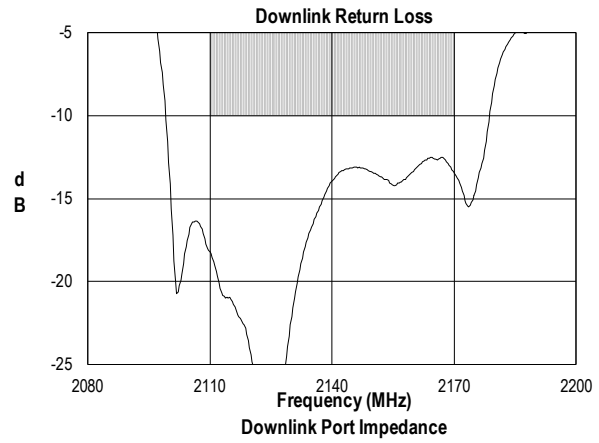
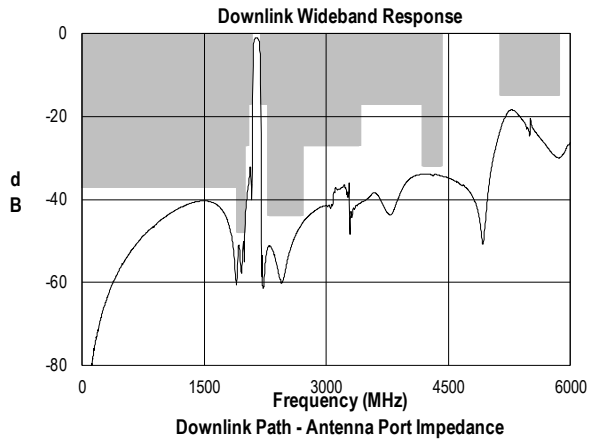
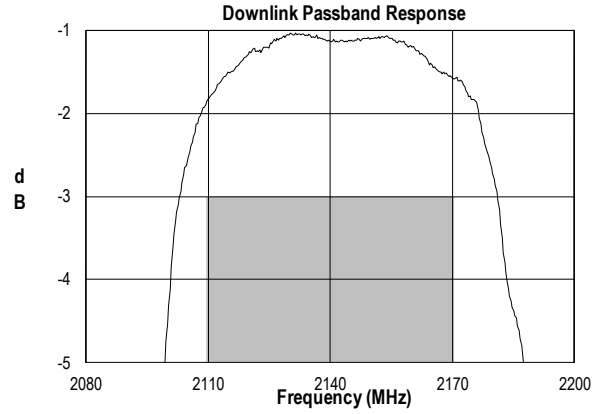
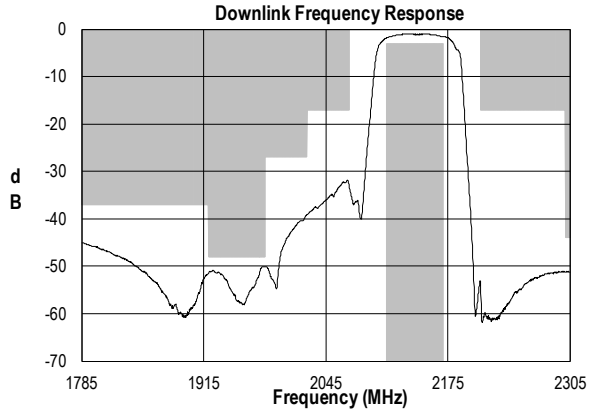

Performance Plots Isolation

Test conditions unless otherwise noted: Temp= +25°C

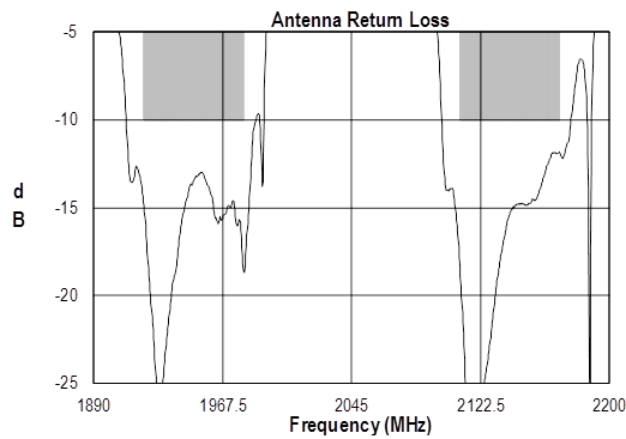
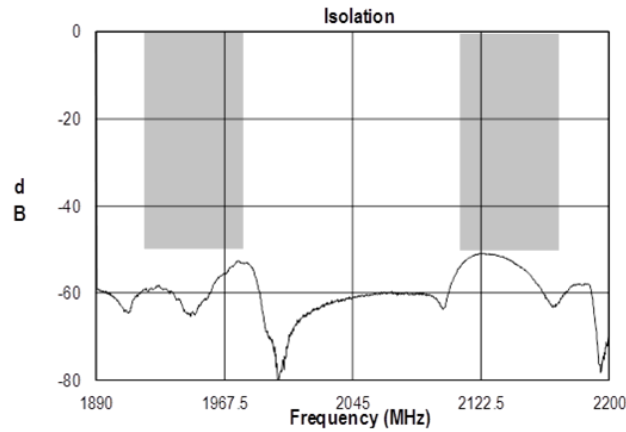

Package Dimensions

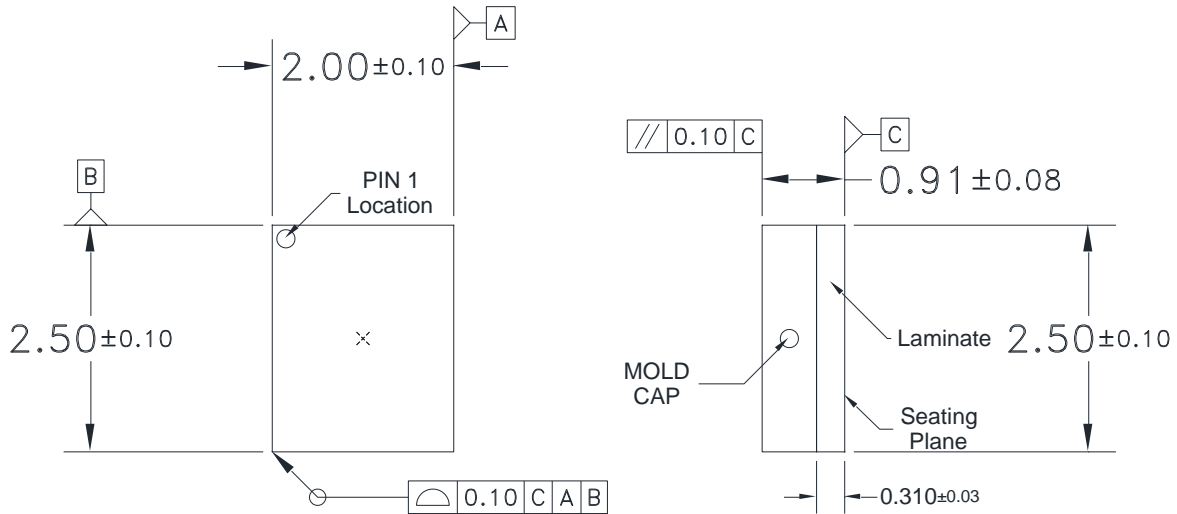

TOP VIEW

SIDE VIEW

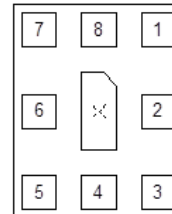
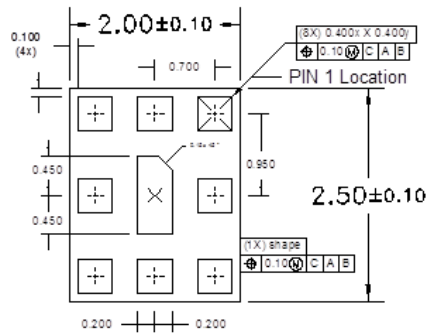

BOTTOM VIEW

BOTTOM PINS VIEW

Notes:

1. All dimensions are in millimeters. Angles are in degrees.
2. Dimension and tolerance formats conform to ASME Y14.4M-1994.
3. The terminal #1 identifier and terminal numbering conform to JESD 95-1 SPP-012.

Package Marking

Package Marking

Qorvo Logo
 Product Identifier: 1282
 Trace Code: XXXX



PCB Mounting Pattern

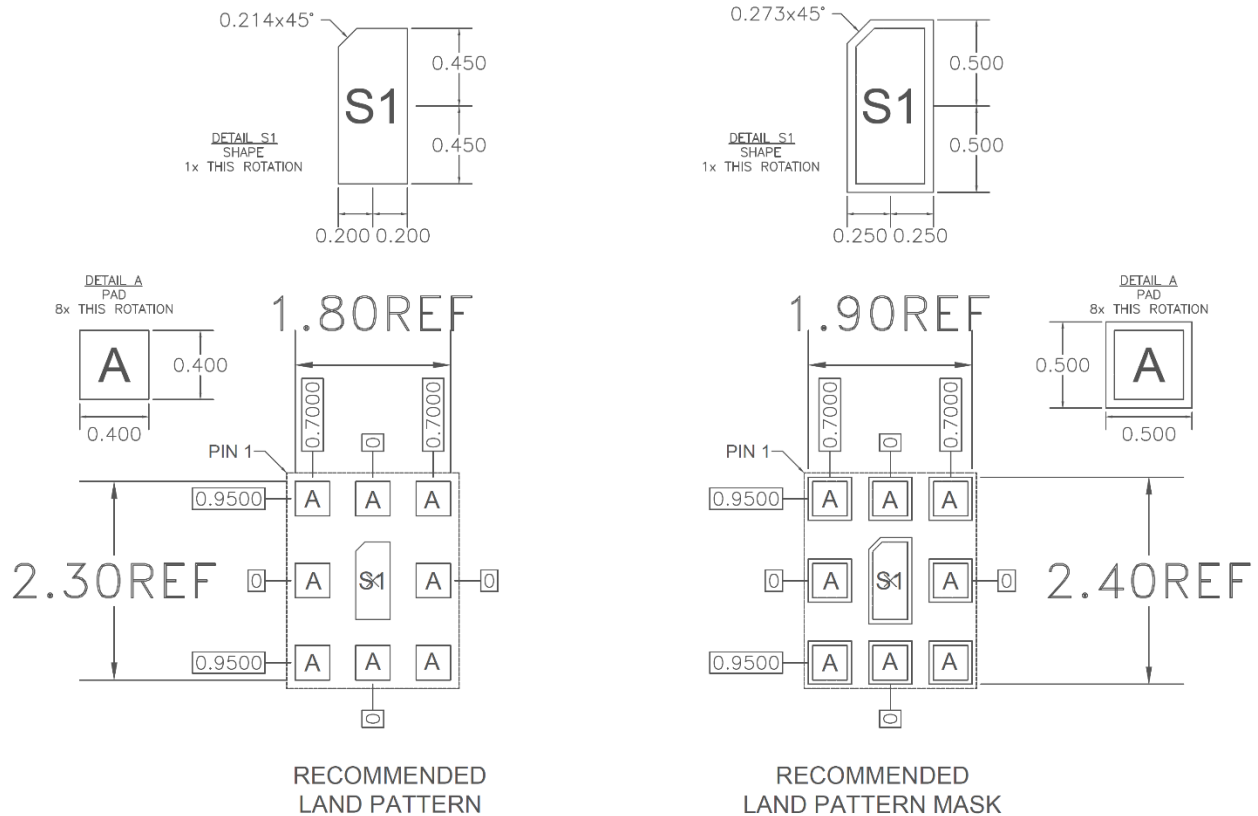

Notes:

1. All dimensions are in millimeters. Angles are in degrees.
2. This drawing specifies the mounting pattern used on the Qorvo evaluation board for this product. Some modification may be necessary to suit end user assembly materials and processes.

Tape and Reel Information – Carrier and Cover Tape Dimensions

Tape and reel specifications for this part are also available on the Qorvo website.
 Standard T/R size = 2500 pieces on a 7” reel.

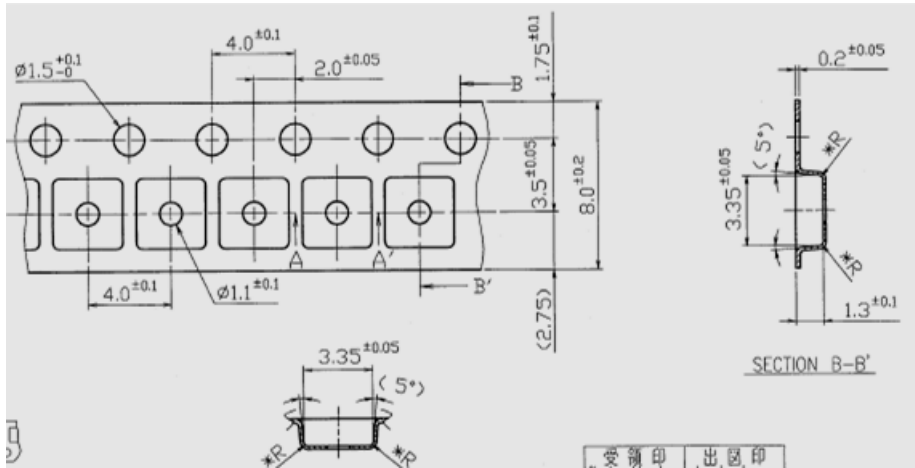

Feature	Measure	Symbol	Size (in)	Size (mm)
Cavity	Length	A0	0.092	2.34
	Width	B0	0.112	2.85
	Depth	K0	0.043	1.10
	Pitch	P1	0.157	4.00
Centerline Distance	Cavity to Perforation - Length Direction	P2	0.079	2.00
	Cavity to Perforation - Width Direction	F	0.138	3.50
Cover Tape	Width	C	0.213	5.40
Carrier Tape	Width	W	0.315	8.00

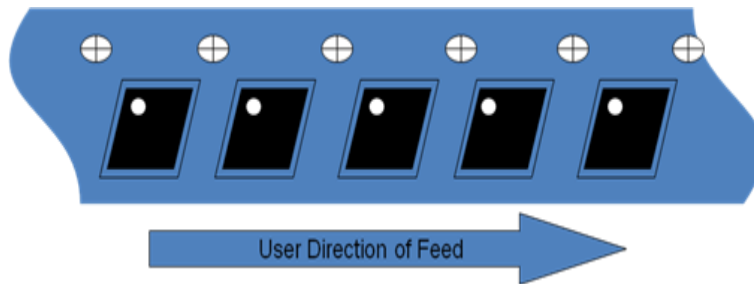

Tape and Reel Information – Reel Dimensions

Tape and reel specifications for this part are also available on the Qorvo website.
 Standard T/R size = 2,500 pieces on a 7" reel.

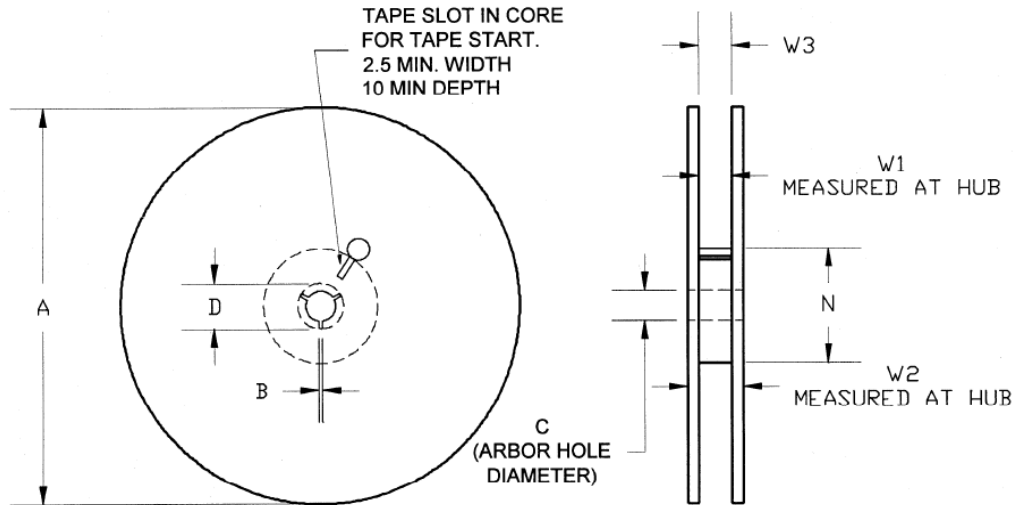

Feature	Measure	Symbol	Size (in)	Size (mm)
Flange	Diameter	A	6.969	177.0
	Thickness	W2	0.559	14.2
	Space Between Flange	W1	0.346	8.8
Hub	Outer Diameter	N	2.283	58.0
	Arbor Hole Diameter	C	0.512	13.0
	Key Slit Width	B	0.079	2.0
	Key Slit Diameter	D	0.787	20.0

Handling Precautions

Parameter	Rating	Standard
ESD – Human Body Model (HBM)	Class 1B	ESDA / JEDEC JS-001-2012
ESD – Charged Device Model (CDM)	Class C3	ESDA / JEDEC JS-002-2014
MSL – Moisture Sensitivity Level	Level 3	IPC/JEDEC J-STD-020



Caution!
 ESD-Sensitive Device

Solderability

Compatible with both lead-free (260°C max. reflow temp.) and tin/lead (245°C max. reflow temp.) soldering processes. Solder profiles available upon request.

Contact plating: ENIG (Electroless Nickel Immersion Gold)

RoHS Compliance

This part is compliant with 2011/65/EU RoHS directive (Restrictions on the Use of Certain Hazardous Substances in Electrical and Electronic Equipment) as amended by Directive 2015/863/EU.

This product also has the following attributes:

- Lead Free
- Halogen Free (Chlorine, Bromine)
- Antimony Free
- TBBP-A (C₁₅H₁₂Br₄O₂) Free
- PFOS Free
- SVHC Free



Contact Information

For the latest specifications, additional product information, worldwide sales and distribution locations:

Web: www.qorvo.com

Tel: 1-844-890-8163

Email: customer.support@qorvo.com

Important Notice

The information contained herein is believed to be reliable; however, Qorvo makes no warranties regarding the information contained herein and assumes no responsibility or liability whatsoever for the use of the information contained herein. All information contained herein is subject to change without notice. Customers should obtain and verify the latest relevant information before placing orders for Qorvo products. The information contained herein or any use of such information does not grant, explicitly or implicitly, to any party any patent rights, licenses, or any other intellectual property rights, whether with regard to such information itself or anything described by such information. **THIS INFORMATION DOES NOT CONSTITUTE A WARRANTY WITH RESPECT TO THE PRODUCTS DESCRIBED HEREIN, AND QORVO HEREBY DISCLAIMS ANY AND ALL WARRANTIES WITH RESPECT TO SUCH PRODUCTS WHETHER EXPRESS OR IMPLIED BY LAW, COURSE OF DEALING, COURSE OF PERFORMANCE, USAGE OF TRADE OR OTHERWISE, INCLUDING THE IMPLIED WARRANTIES OF MERCHANTABILITY AND FITNESS FOR A PARTICULAR PURPOSE.**

Without limiting the generality of the foregoing, Qorvo products are not warranted or authorized for use as critical components in medical, life-saving, or life-sustaining applications, or other applications where a failure would reasonably be expected to cause severe personal injury or death.

Copyright 2019 © Qorvo, Inc. | Qorvo is a registered trademark of Qorvo, Inc.

Looking for pricing, stock, or lifecycle information?

Click below to explore more details on WIN SOURCE:

 [View QPQ1282TR7 on WIN SOURCE](#)

 [Qorvo US Inc. Information](#)

Optimize Your Supply Chain with WIN SOURCE Solutions

-  Global Sourcing Solution
-  Obsolete Management
-  Cost Control Management
-  Shortage Management
-  Alternative Solution
-  Excess Inventory Management