

EAN code  
HRH-9: 8595188181334  
HRH-9/S: 8595188181853

**Technical parameters** **HRH-9**

Supply	
Supply terminals:	A1 - A2
Supply voltage:	AC/DC 24 to 240V (AC 50-60Hz)
Supply voltage tolerance:	-15% +10%
galvanically separated voltage:	yes
Burden max.:	2W, 4VA
Max. dissipated power (Un + terminals):	10 W
Power indication:	green LED
Measuring circuit	
Number of level probes:	6 + 1 common
Adjustable probe function:	PUMP UP, PUMP DOWN, ON, OFF
Voltage on probes:	5V AC max./10Hz
Time reaction in probes:	1,1s
Time delay (PROBE DELAY):	adjustable 0.5 - 10s
Max. capacity of probe cable:	16nF (sensitivity 470 kΩ), 500nF (sensitivity 9,1 kΩ)
Probe sensitivity calibration range:	10kΩ to 470kΩ
Sensitivity range of probes manually (for probes 4, 5, 6):	50kΩ to 470 kΩ
Time delay (START DELAY):	adjustable 0 to 30min
Probe status indication:	red LED + external LED

Output	
Number of contacts:	6x NO (AgSnO <sub>2</sub> )
Current rating:	10 A/AC1; 1/3 HP 240 Vac; PD. B300
Switching voltage max.:	250V AC
Breaking capacity max.:	2500VA
Mechanical life:	10.000.000 ops.
Electrical life (AC1):	100.000 ops.

Other information	
Operating temperature:	
Storage temperature:	-20 .. +55°C (-4 .. 131 °F)
Dielectrical strength:	-30 .. +70°C (-22 .. 158 °F)
power supply - probes	AC 4kV
power supply - relay contacts	AC 4kV
contacts of adjacent relays	AC 4kV
Operating position:	any
Mounting:	DIN rail EN 60715
Protection degree:	IP40 from front panel/IP20 terminals
Overvoltage category:	III.
Pollution degree:	2
Max. cable size (mm <sup>2</sup> )	
probes/power supply/signaling:	solid wire max. 1x 2.5 or 2x1.5/with cavern max. 1x 1.5 (AWG 12)
output part:	solid wire max. 1x 2.5 or 2x1.5/with cavern max. 1x 1.5 (AWG 12)
Dimensions:	90 x 105 x 65mm (3.5" x 4.1" x 2.6")
Weight:	252 g (8.9 oz.)
Standards:	EN 60255-1, EN 60255-26, EN 60255-27, EN 60669-1, EN 60669-2-1

- The relay is designed to control the level of conductive liquids in wells, sumps, tanks, pools, tankers, reservoirs ...
- Galvanically separated power and monitoring circuits.
- Possibility to connect up to 6 level probes (+ one common probe).
- Each probe has its own output relay function selection for each probe separately.
- Adjustable delay after power on (START Delay).
- Adjustable relay closing delay (Probe Delay) - common for all probes.
- Automatic calibration of the sensitivity of the probes according to the conductivity of the monitored liquid.
- For probes 4, 5, 6 possibility of manual sensitivity adjustment.
- A monitoring frequency of 10 Hz prevents polarization of the liquid and increases the resistance to mains frequency interference.

**Description**

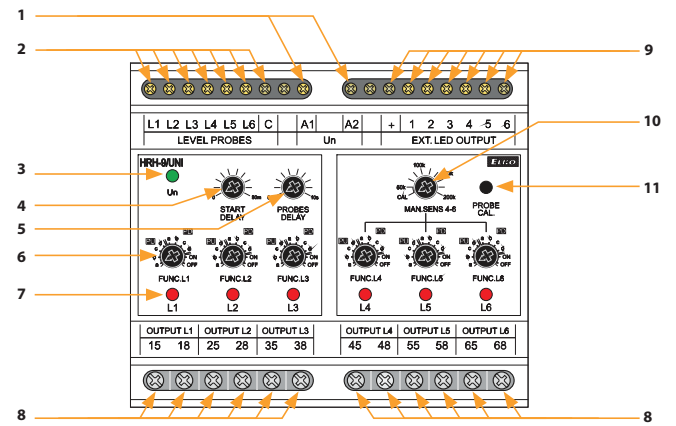

- |                                    |   |
|------------------------------------|---|
| 1 Supply voltage terminals         | 7 Probe status indication (L1)                        |
| 2 Terminals for probes connection  | 8 Probe output contact (L1)                           |
| 3 Supply voltage indication        | 9 Terminals for connecting external signaling HRH-9/S |
| 4 Setting delay after switching on | 10 Manual adjustment of probe sensitivity L4,L5, L6   |
| 5 Delay setting relay closing      | 11 Calibration button of connected probes             |
| 6 Probe function setting (L1)      |   |

**Description**

HRH-9/S

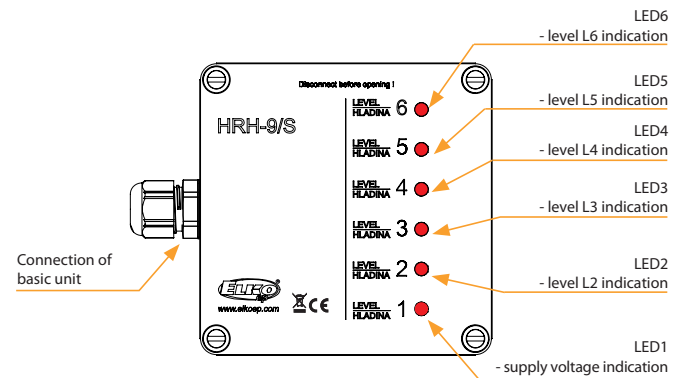

**Function**

**Green LED Un:**

- Flashes for START DELAY after the power is turned on
- During this time the device does not respond to the state of the level probes

- After START DELAY, the green LED lights up permanently

**START DELAY control:**

- sets the START DELAY, delay in the range 0 to 30 minutes

**Level probe function switch FUNC. L1 (L2 to L6):**

A total of 6 level probes L1 to L6 + common probe C can be connected to the device. Each probe has its own function switch, which sets the functions PUMP UP, PUMP DOWN, ON - permanently

Relay closed, OFF - permanently open relay.

- Positions 1 - 4 = PUMP UP

- Positions 5 - 8 = PUMP DOWN

- Position 9 = ON (relay permanently closed, red LED lit)

- Position 10 = OFF (relay open, red LED not lit)

Each of the PUMP UP, PUMP DOWN functions has 4 response delay setting options:

a - function without delay

b - ON DELAY - delayed closing of the relay

c - OFF DELAY - delayed opening of the relay

d - ON/OFF DELAY - delayed closing and opening of the relay

Each probe then controls its output relay depending on the function switch setting. If a probe is not used, its switch must be set to OFF or ON.

**PROBES DELAY control:**

- sets the delay of the relay response to the change of the state of the level probes

- Delay is standard for all probes - range 0.5 to 10s

**LED indication of the status of probes L1 to L6:**

Each probe has its own red LED, indicating the status of the probe + output for external LED additional signalling, which copies the status of the internal red LED:

- Probe is not immersed - the red LED is off
- Probe is immersed, the delay is not running - the red LED is lit.
- Probe has just been immersed and the delay is running - red LED flashes (shorter pulse)
- Probe has just surfaced and a delay is running - red LED flashes (longer pulse)
- Calibration error - red LED flashes quickly

**Wiring example**

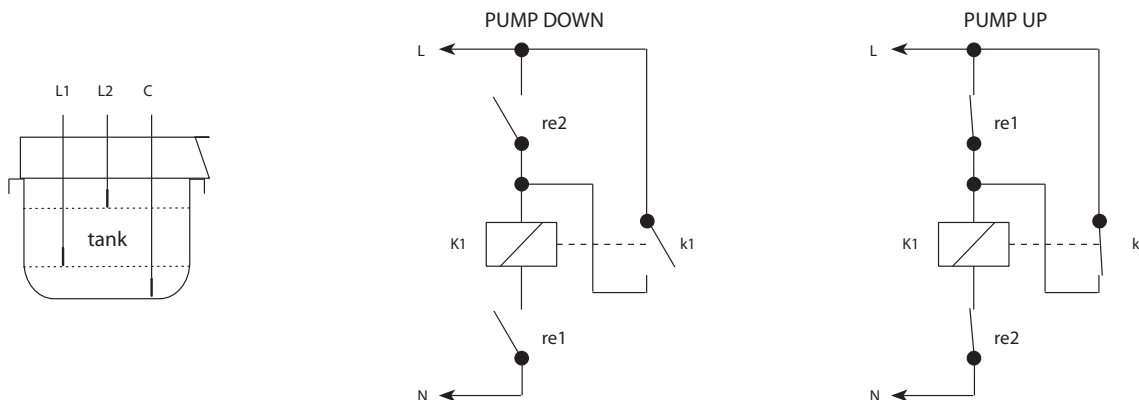

**Level probes in the tank:**

- the common probe C is positioned so that it is always immersed
- the position of the L1 probe determines the lower level, the position of the L2 probe determines the upper level
- the connection is used to maintain the level between the L1 and L2 probes

**Description of the PUMP DOWN function:**

- if the tank is empty, both probes L1 and L2 are not immersed, both relays re1 and re2 are open. Contactor K1 controlling the pump is also open (pump stopped)
- if the tank is filled, after reaching the L1 level the relay re1 closes and the state does not change further
- after reaching the level L2 the relay re2 closes and at the same time the contactor K1 closes (the pump works)
- when the level drops below L2, relay re2 opens, but the contactor remains closed via its switching contact k1
- when the level drops below L1, relay re1 opens and at the same time contactor K1 opens (pump stops)

**Description of the PUMP UP function:**

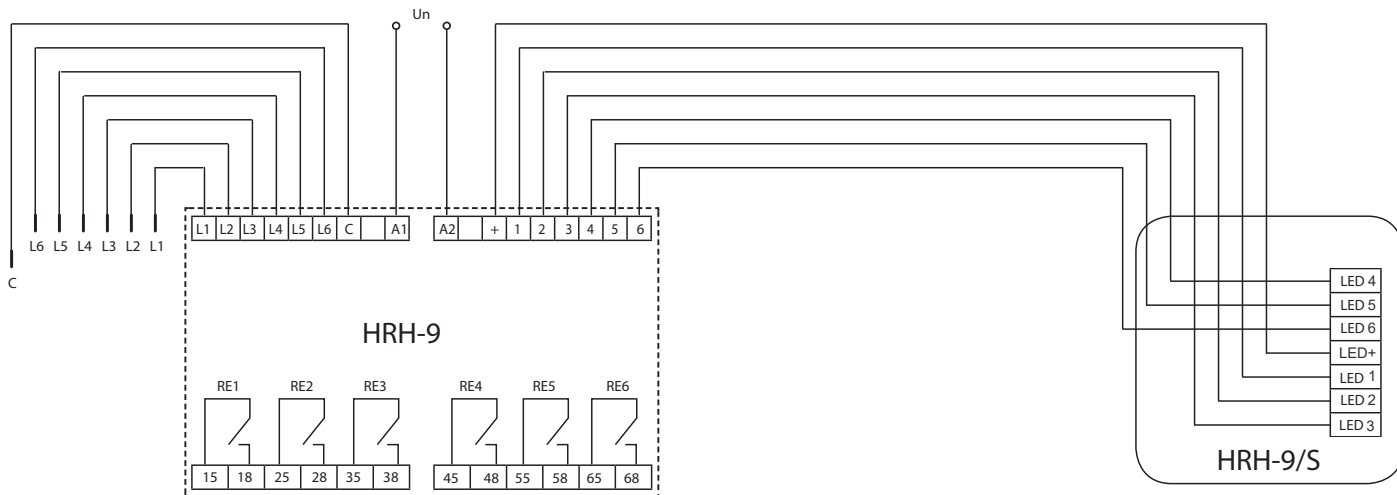

- if the tank is empty, both probes L1 and L2 are not immersed, both relays re1 and re2 are closed. Contactor K1 controlling the pump is closed (pump is running)
- if the tank is filled, after reaching the level L1 the relay re1 opens - the state does not change - the contactor remains closed via its switching contact k1
- after reaching the level L2, the relay re2 opens and at the same time the contactor K1 (the pump stops)
- when the level drops below L2, relay re2 closes and the state does not change further
- when the level drops below L1, relay re1 closes and at the same time contactor K1 closes (pump starts)

**Connection with additional signalization HRH-9/S**



## Looking for pricing, stock, or lifecycle information?

Click below to explore more details on WIN SOURCE:

-  [View HRH-9 on WIN SOURCE](#)
-  [ELKO EP North America LLC Information](#)

## Optimize Your Supply Chain with WIN SOURCE Solutions

-  Global Sourcing Solution
-  Obsolete Management
-  Cost Control Management
-  Shortage Management
-  Alternative Solution
-  Excess Inventory Management