

General Description

Qorvo’s QPA1013D is a broadband high power MMIC amplifier fabricated on Qorvo’s production 0.15 um GaN on SiC process (QGAN15). The QPA1013D operates from 6–18 GHz and provides more than 10 W saturated output power with power-added efficiency >20% and large-signal gain >20 dB. This combination of wideband performance provides the flexibility designers are looking for to improve system performance while reducing size and cost.

The QPA1013D is matched to 50 Ω with integrated DC blocking capacitors on both RF I/O ports simplifying system integration. The broadband performance makes it ideally suited in support of test instrumentation and electronic warfare, as well as, supporting multiple radar and communication bands.

The QPA1013D is 100% DC and RF tested on-wafer to ensure compliance to electrical specifications.

Lead-free and RoHS compliant.

Functional Block Diagram

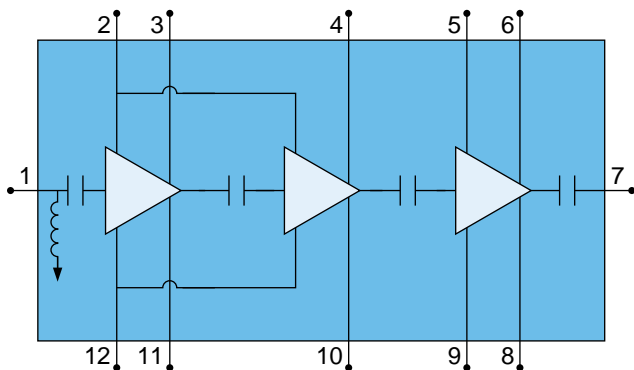

Product Features

- Frequency Range: 6–18 GHz
- P_{OUT}: > 40 dBm (P_{IN} = 20 dBm)
- PAE: > 20% (P_{IN} = 20 dBm)
- Large Signal Gain: > 20 dB (P_{IN} = 20 dBm)
- Small Signal Gain: > 25 dB
- Return Loss: > 6.5 dB
- Bias: V_D = 20 V, I_{DQ} = 1250 mA
- Chip Dimensions: 5.05 x 3.55 x 0.10 mm

Applications

- Test Instrumentation
- Electronic Warfare (EW)
- Radar
- Communications

Ordering Information

Part	Description
QPA1013D	6–18 GHz 10 W GaN Power Amplifier
QPA1013DEVBP01	Evaluation Board

Absolute Maximum Ratings

Parameter	Value/Range
Drain Voltage (V_D)	29.5 V
Gate Voltage Range (V_G)	-8 to 0 V
Drain Current (I_{D1})	480 mA
Drain Current (I_{D2})	720 mA
Drain Current (I_{D3})	2880 mA
Gate Currents ($I_{G1}/I_{G2}/I_{G3}$)	See plot on page 3
Power Dissipation (P_{DISS}), 85 °C, CW	75 W
Input Power (P_{IN}), 50 Ω , $V_D = 20$ V, $I_{DQ} = 1250$ mA, 85 °C, CW	28 dBm
Input Power (P_{IN}), $V_{SWR} 3:1$, $V_D = 20$ V, $I_{DQ} = 1250$ mA, 85 °C, CW	28 dBm
Mounting Temperature (30 seconds)	320 °C
Storage Temperature	-55 to 150 °C

Operation of this device outside the parameter ranges given above may cause permanent damage. These are stress ratings only, and functional operation of the device at these conditions is not implied.

Recommended Operating Conditions

Parameter	Value/Range
Drain Voltage (V_D)	20 V
Drain Current (I_{DQ})	1250 mA (Total)
Gate Voltage Range (V_G)	-2.8 to -2.0 V

Electrical specifications are measured at specified test conditions. Specifications are not guaranteed over all operating conditions.

Electrical Specifications

Test conditions unless otherwise noted: 25 °C, $V_D = 20$ V, $I_{DQ} = 1250$ mA

Parameter	Min	Typical	Max	Units
Operational Frequency Range	6		18	GHz
Small Signal Gain		>25		dB
Input Return Loss		>6.5		dB
Output Return Loss		>7		dB
Power Gain ($P_{IN} = 20$ dBm)		>20		dB
Output Power ($P_{IN} = 20$ dBm)		>40		dBm
Power Added Efficiency ($P_{IN} = 20$ dBm)		22		%
Gate Leakage ($V_D = 10$ V, $V_G = -6.0$ V)	-19.6		-0.0001	mA
Small Signal Gain Temperature Coefficient		-0.061		dB/°C
Output Power Temperature Coefficient (Calculated from 25 °C to 85 °C) ($P_{in} = 20$ dBm)		-0.017		dBm/°C

Typical Performance (Small Signal)

Test conditions unless otherwise noted: 25 °C , $V_D = 20$ V, $I_{DQ} = 1250$ mA

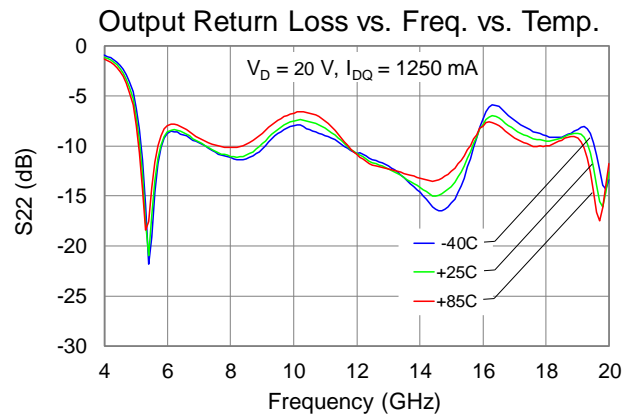
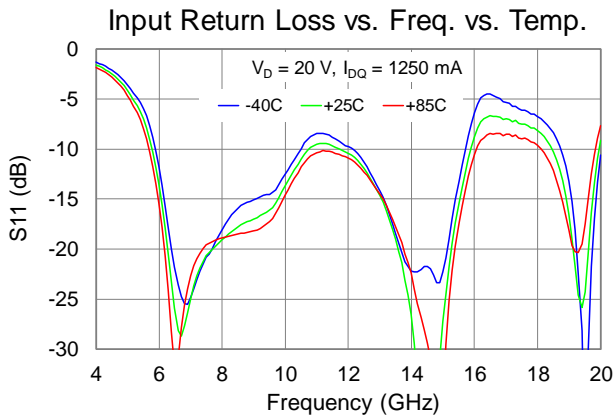
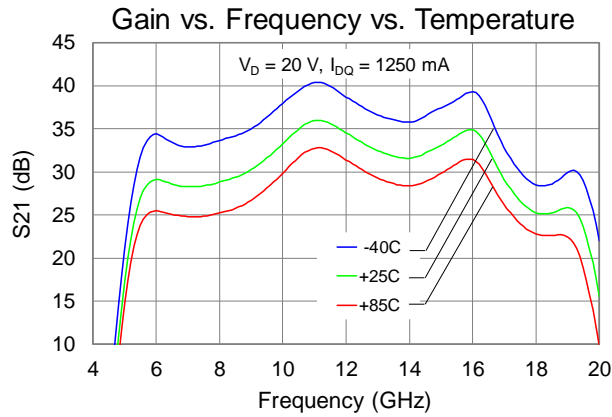
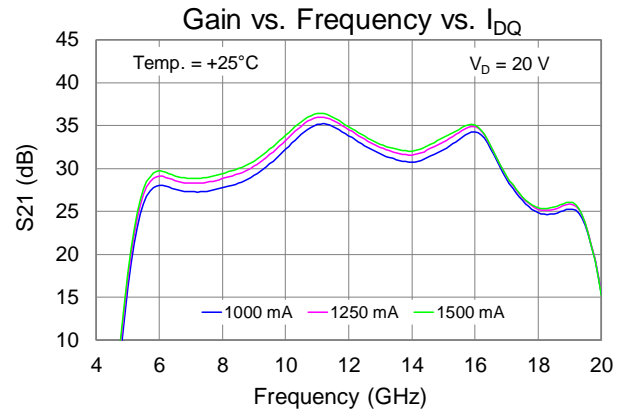
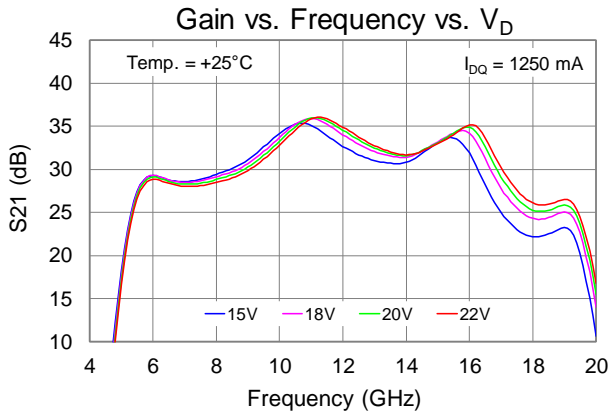

Typical Performance (CW)

Test conditions unless otherwise noted: 25 °C , $V_D = 20\text{ V}$, $I_{DQ} = 1250\text{ mA}$

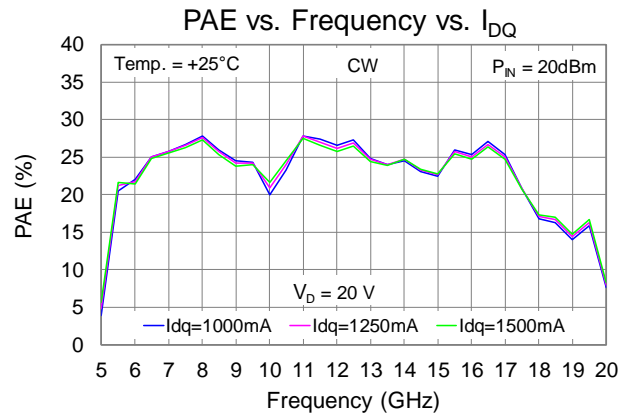
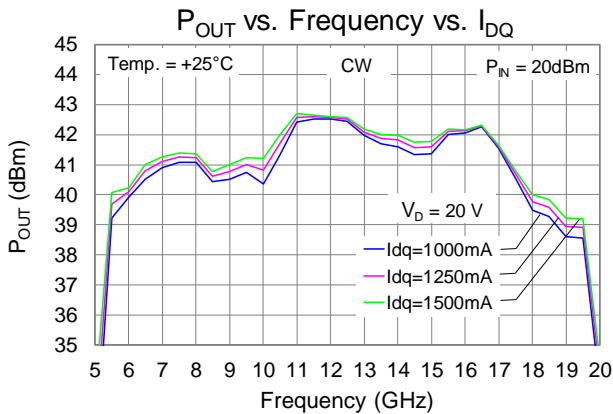
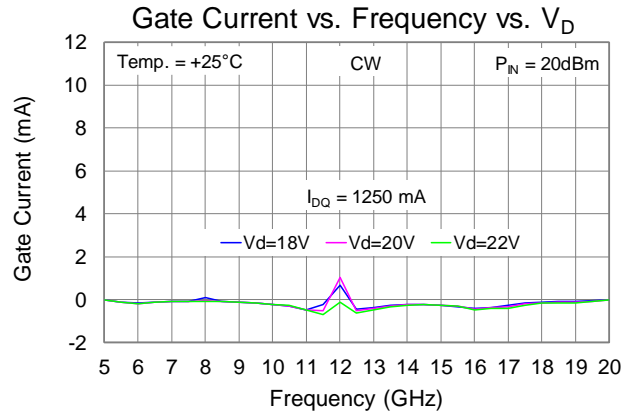
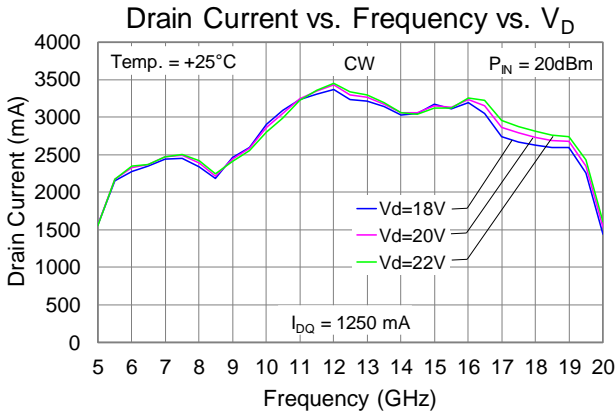
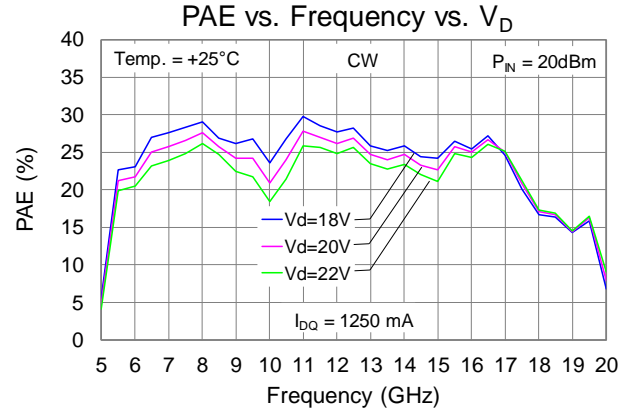
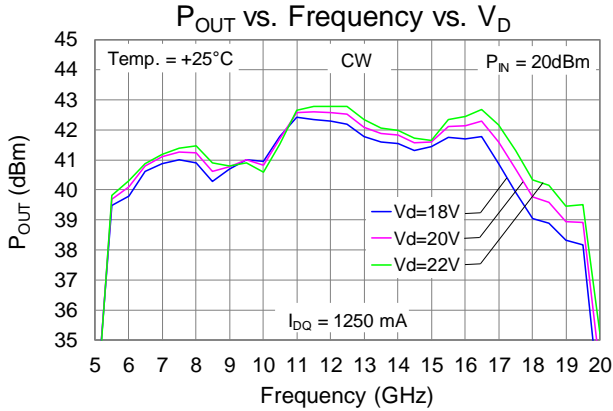

Typical Performance (CW)

Test conditions unless otherwise noted: 25 °C , $V_D = 20$ V, $I_{DQ} = 1250$ mA

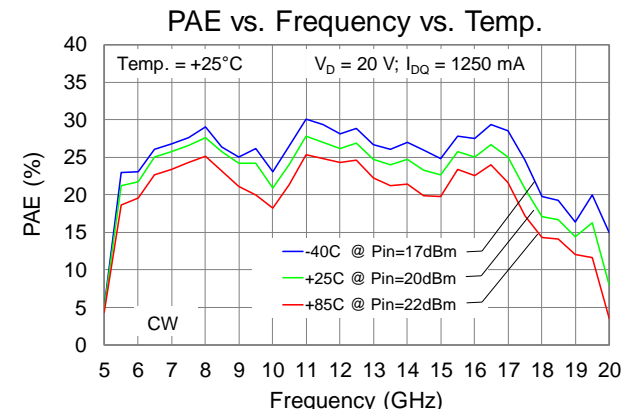
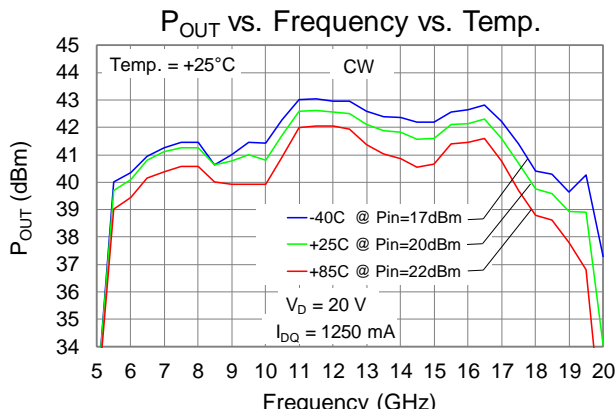
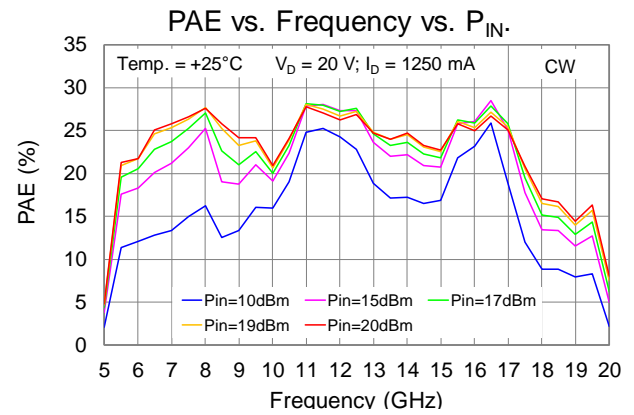
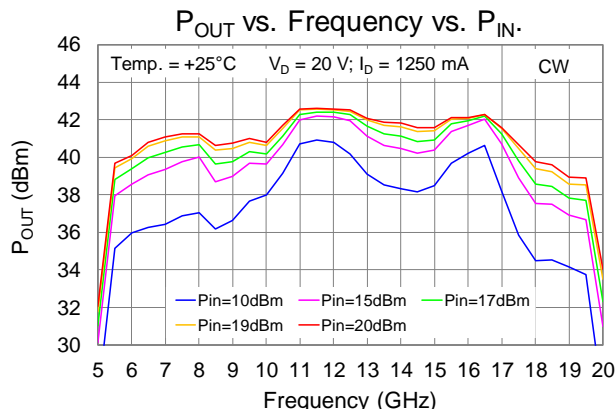
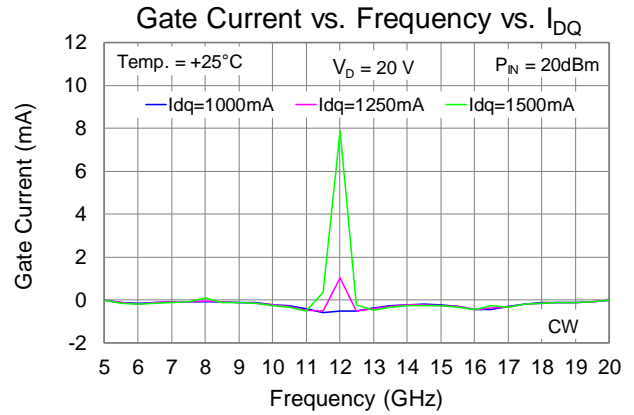
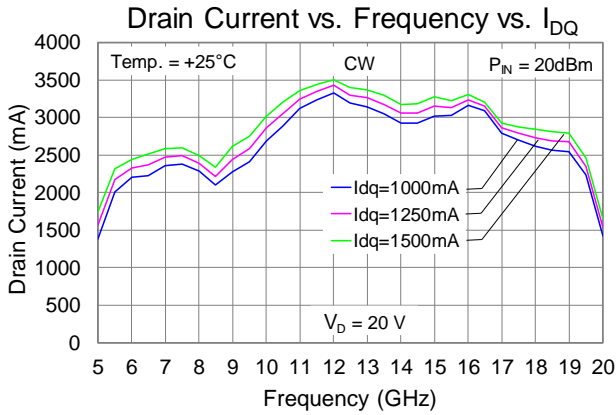

Typical Performance (CW)

Test conditions unless otherwise noted: 25 °C , $V_D = 20$ V, $I_{DQ} = 1250$ mA

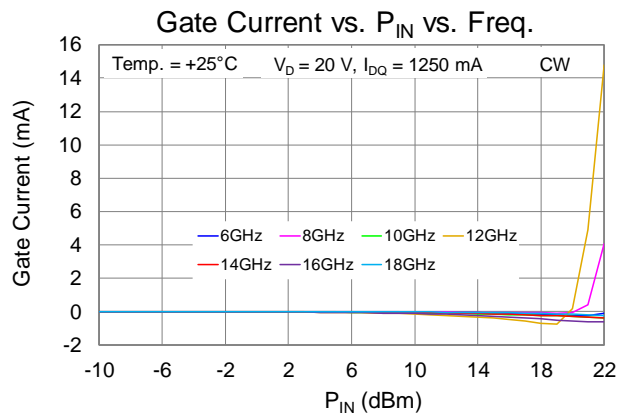
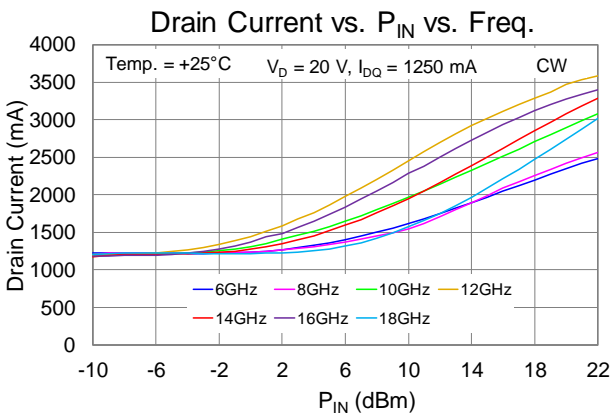
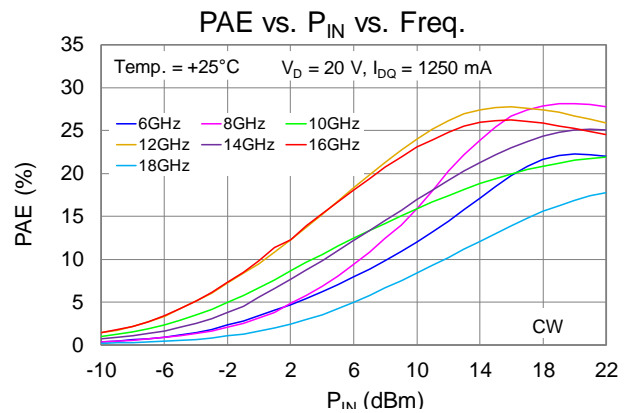
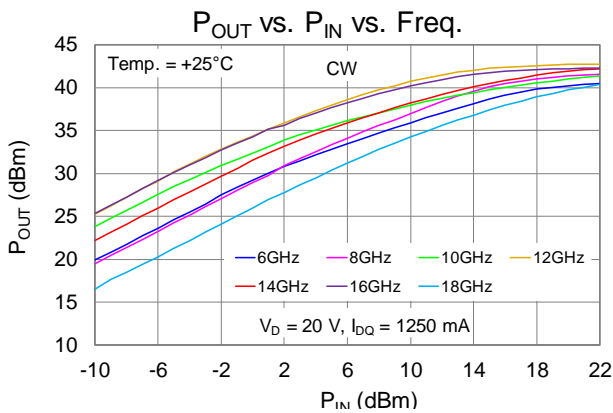
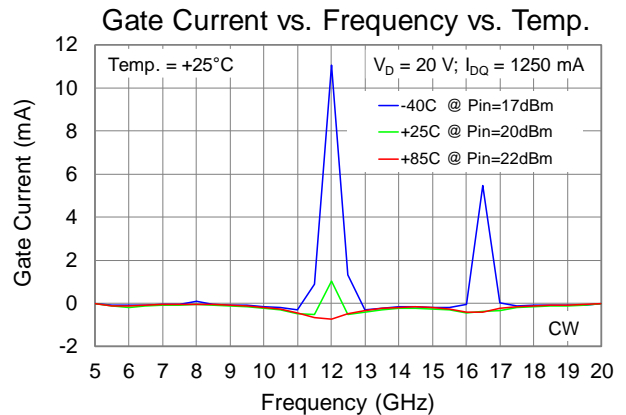
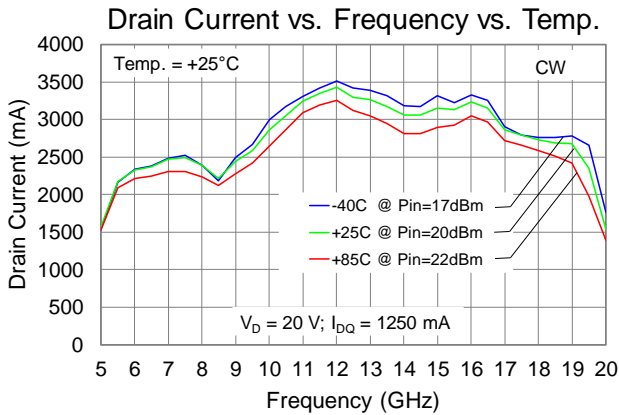

Typical Performance (Linearity)

Test conditions unless otherwise noted: 25 °C , $V_D = 20$ V, $I_{DQ} = 1250$ mA

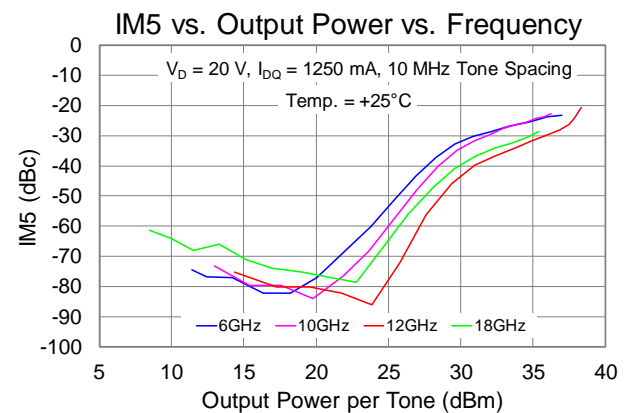
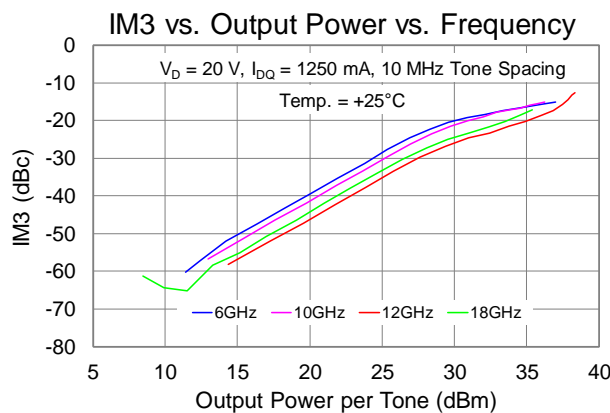
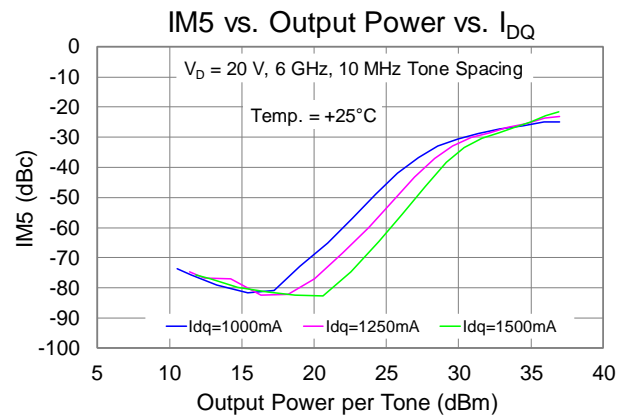
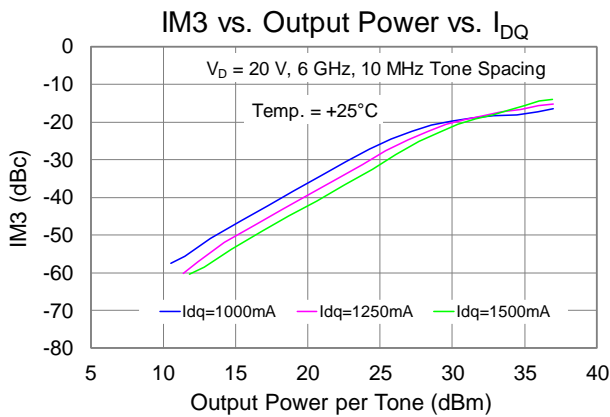
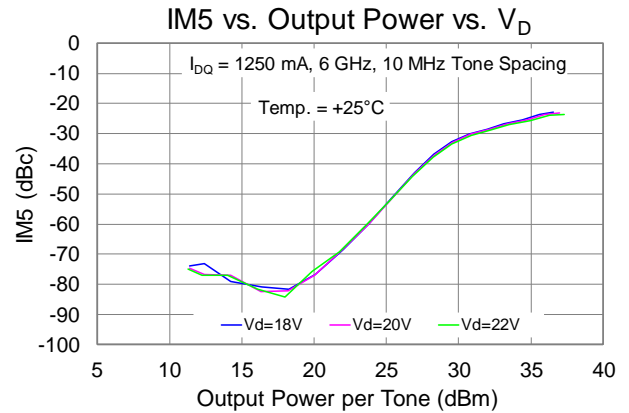
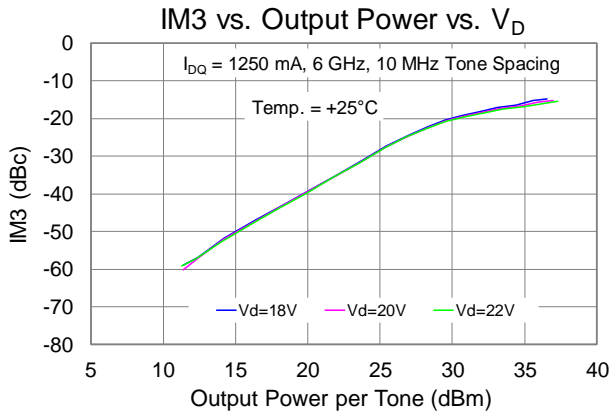

Typical Performance (Linearity)

Test conditions unless otherwise noted: 25 °C , $V_D = 20\text{ V}$, $I_{DQ} = 1250\text{ mA}$

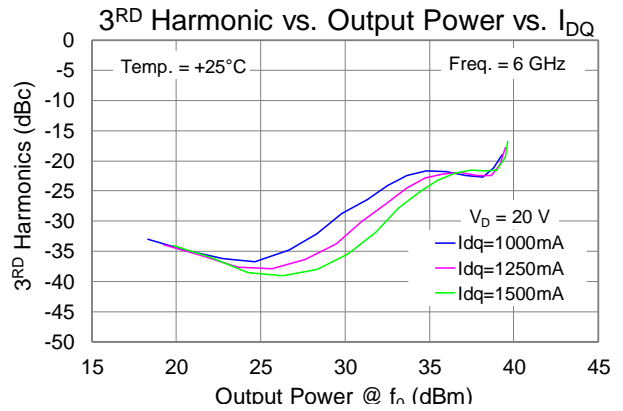
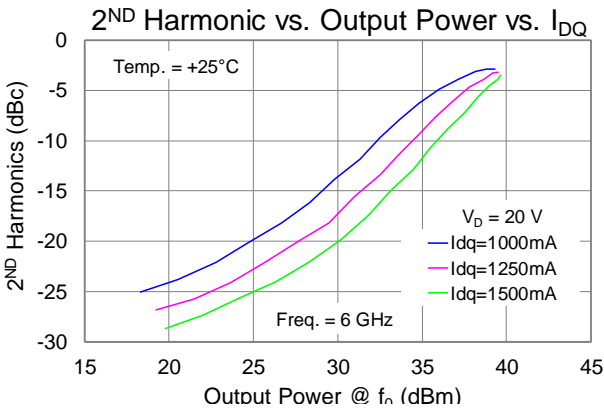
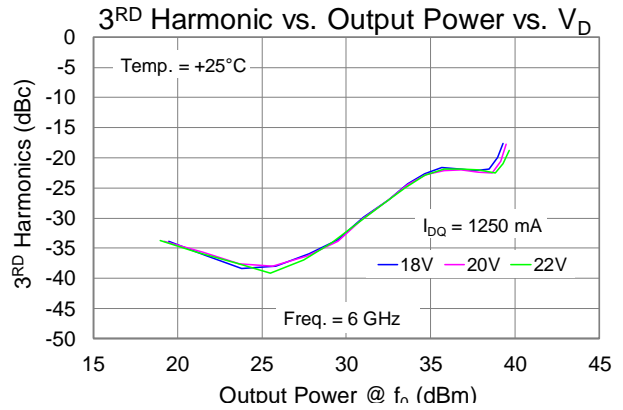
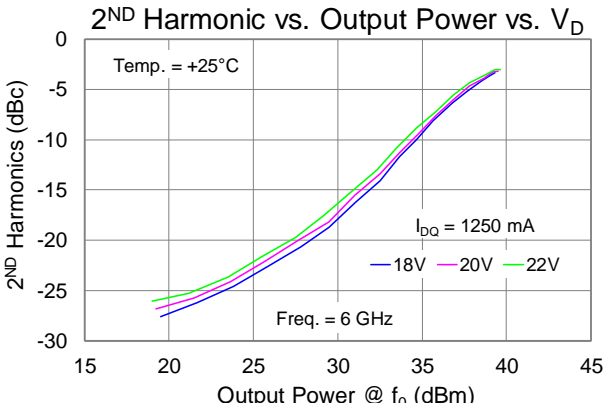
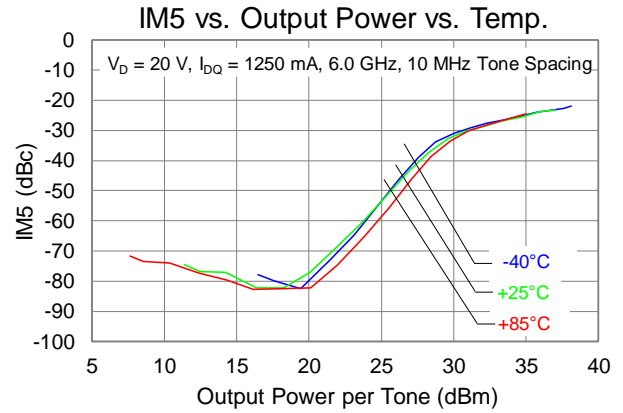
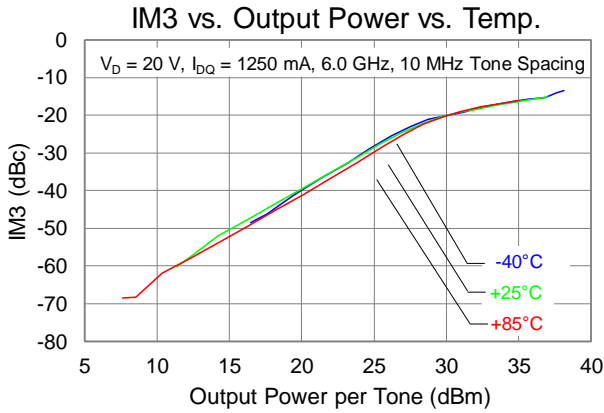

Typical Performance (Linearity)

Test conditions unless otherwise noted: 25 °C , $V_D = 20\text{ V}$, $I_{DQ} = 1250\text{ mA}$

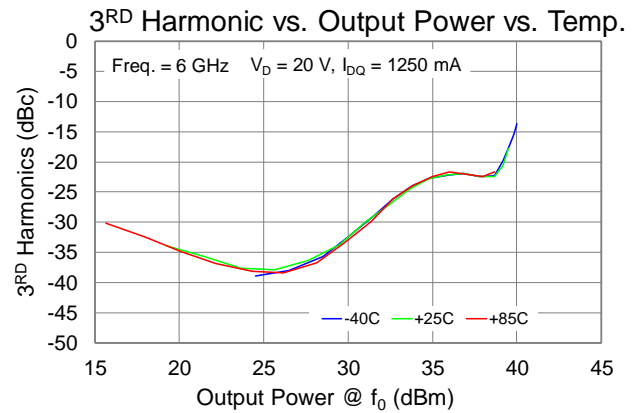
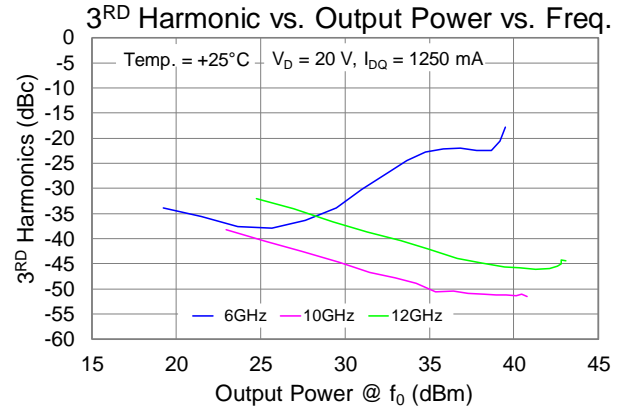
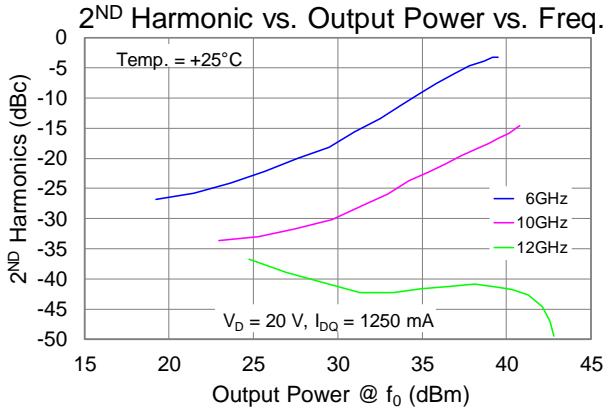

Thermal and Reliability Information

Parameter	Conditions	Value	Units
Thermal Resistance (θ_{JC}) ⁽¹⁾	$T_{BASE} = 85\text{ }^{\circ}\text{C}$, CW, $V_D = 20\text{ V}$, $I_{DQ} = 1250\text{ mA}$ $P_{DISS} = 25\text{ W}$	1.700	$^{\circ}\text{C/W}$
Channel Temperature (T_{CH}) (No RF drive) ⁽²⁾		127.5	$^{\circ}\text{C}$
Thermal Resistance (θ_{JC}) ⁽¹⁾	$T_{BASE} = 85\text{ }^{\circ}\text{C}$, $V_D = 20\text{ V}$, $I_{DQ} = 1250\text{ mA}$, CW $I_{D_Drive} = 3.3\text{ A}$, $F_{REQ} = 12\text{ GHz}$, $P_{IN} = 22\text{ dBm}$, $P_{OUT} = 42\text{ dBm}$, $P_{DISS} = 49\text{ W}$	1.910	$^{\circ}\text{C/W}$
Channel Temperature (T_{CH}) (Under RF drive) ⁽²⁾		178.6	$^{\circ}\text{C}$

Notes:

1. Thermal resistance measured to back of carrier plate. MMIC mounted on copper-moly carrier using AuSn solder.
2. IR Scan equivalent temperature. Refer to the following document: [GaN Device Channel Temperature, Thermal Resistance, and Reliability Estimates](#)

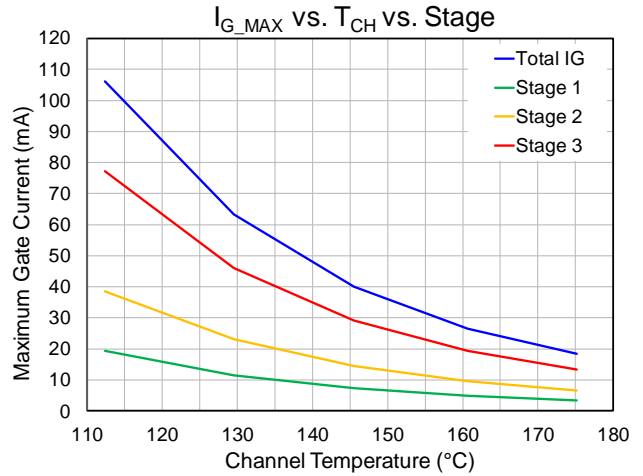
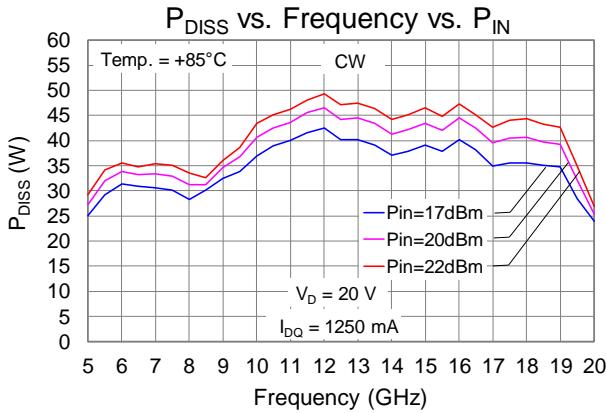

Application Circuit

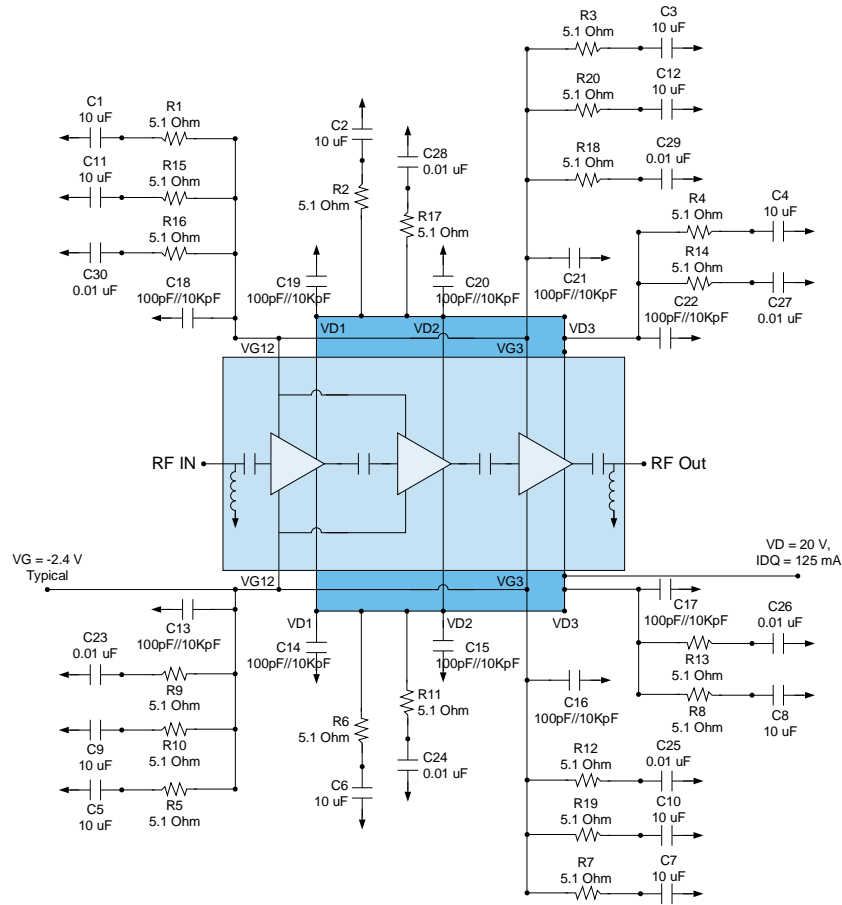

Bias-up Procedure

- Set I_D limit to 4000 mA, I_G limit to 16 mA

- Set V_G to -5.0 V

- Set V_D +20 V

- Adjust V_G more positive until $I_{DQ} = 1250$ mA

- Apply RF signal

Bias-down Procedure

- Turn off RF signal

- Reduce V_G to -5.0 V. Ensure $I_{DQ} \sim 0$ mA

- Set V_D to 0 V

- Turn off V_D supply

- Turn off V_G supply

Evaluation Board (EVB) Layout Assembly

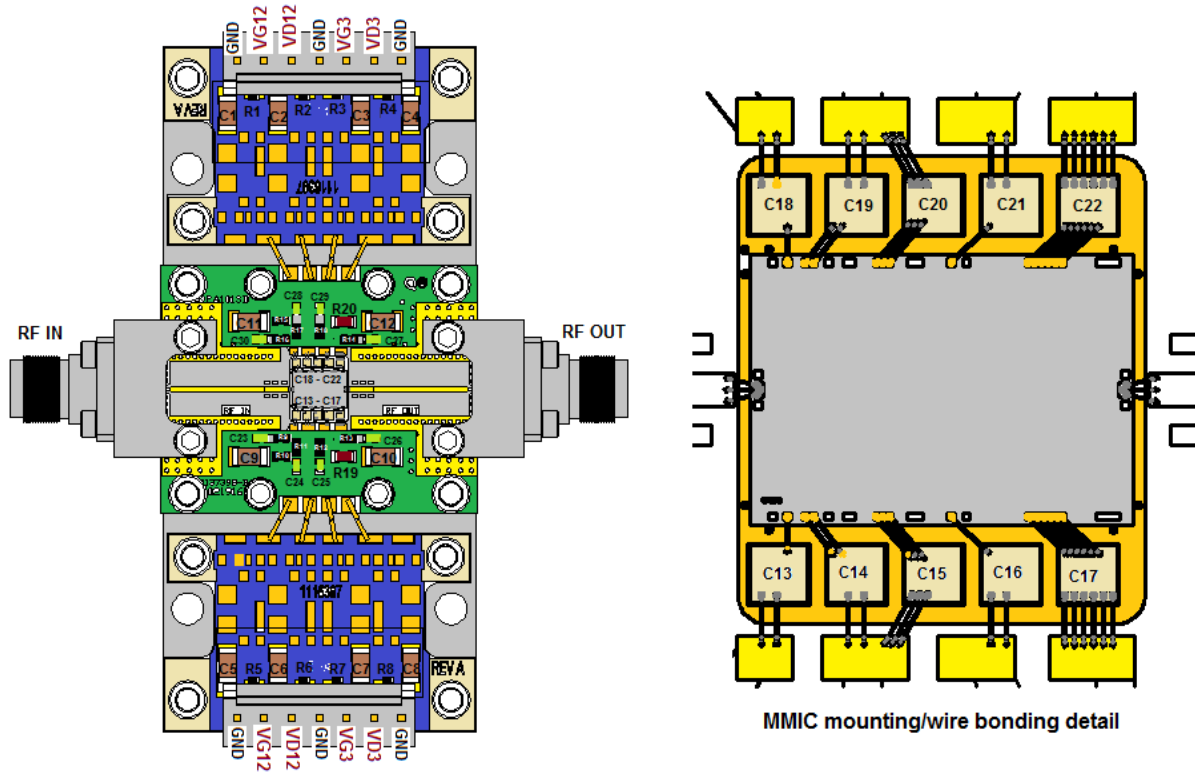

- Notes:
1. The MMIC can be biased from either top or bottom side.

Bill of Materials

Reference Design	Value	Description	Manufacturer	Part Number
C1–C12	10 uF	Cap, 1206, 50 V, 20%, X5R	Various	
C13–C22	100 pF/10k pF	Cap, 30x30, 50 V, Single Layer	Various	
C23–C30	0.01 uF	Cap, 0402, 50 V, 10%, X7R	Various	
R1–R18	5.1 Ω	Res, 0402, 50 V, 5%, SMT	Various	
R19–R20	5.1 Ω	Res, 0603, 1%	Various	

Mechanical Drawing & Bond Pad Description

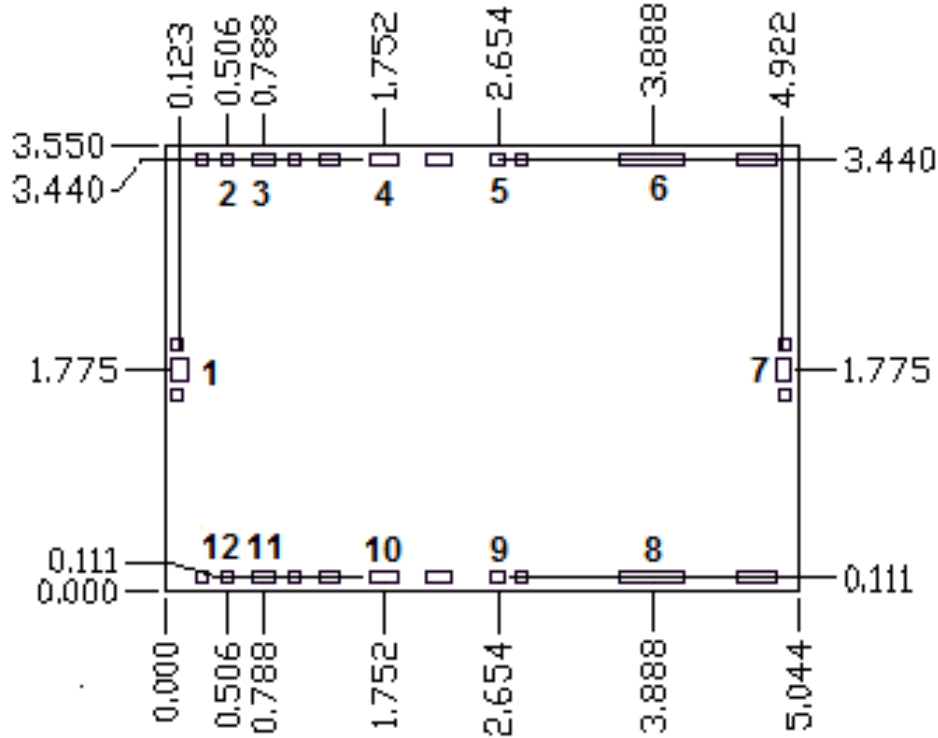

Unit: millimeters
 Thickness: 0.10
 Die x, y size tolerance: +/- 0.050
 Chip edge to bond pad dimensions are shown to center of pad
 Ground is backside of die

Bond Pad	Symbol	Pad Size	Description
1	RF In	0.115 x 0.190	RF Input; matched to 50 Ω; DC shorted to ground
2, 12	VG12	0.090 x 0.090	Gate voltage 1-2, bias network is required; see Application Circuit on page 11 as an example.
3, 11	VD1	0.190 x 0.090	Drain voltage 1, bias network is required; see Application Circuit on page 11 as an example
4, 10	VD2	0.235 x 0.090	Drain voltage 2, bias network is required; see Application Circuit on page 11 as an example.
5, 9	VG3	0.090 x 0.090	Gate voltage 3, bias network is required; see Application Circuit on page 11 as an example.
6, 8	VD3	0.508 x 0.090	Drain voltage 3, bias network is required; see Application Circuit on page 11 as an example.
7	RF Out	0.115 x 0.190	RF Output; matched to 50 Ω; DC shorted to ground

Assembly Notes

Component placement and adhesive attachment assembly notes:

- Vacuum pencils and/or vacuum collets are the preferred method of pick up
- Air bridges must be avoided during placement
- The force impact is critical during auto placement

Reflow process assembly notes:

- Use AuSn (80/20) solder and limit exposure to temperatures above 300 °C to 3-4 minutes, maximum.
- An alloy station or conveyor furnace with reducing atmosphere should be used.
- Do not use any kind of flux.
- Coefficient of thermal expansion matching is critical for long-term reliability.
- Devices must be stored in a dry nitrogen atmosphere.

Interconnect process assembly notes:

- Thermosonic ball bonding is the preferred interconnect technique.
- Force, time, and ultrasonic are critical parameters.
- Aluminum wire should not be used.
- Devices with small pad sizes should be bonded with 0.0007-inch wire.

Handling Precautions

Parameter	Rating	Standard
ESD – Human Body Model (HBM)	1A	JEDEC/JESD22-A114



Caution!
 ESD-Sensitive Device

Solderability

Use AuSn (80/20) solder and limit exposure to temperatures above 300 °C to 3-4 minutes, maximum.

RoHS Compliance

This product is compliant with the 2011/65/EU RoHS directive (Restrictions on the Use of Certain Hazardous Substances in Electrical and Electronic Equipment), as amended by Directive 2015/863/EU. This product also has the following attributes:

- Lead Free
- Halogen Free (Chlorine, Bromine)
- Antimony Free
- TBBP-A (C15H12Br4O2) Free
- PFOS Free
- SVHC Free

Contact Information

For the latest specifications, additional product information, worldwide sales and distribution locations:

Web: www.qorvo.com

Tel: 1-844-890-8163

Email: customer.support@qorvo.com

Important Notice

The information contained herein is believed to be reliable; however, Qorvo makes no warranties regarding the information contained herein and assumes no responsibility or liability whatsoever for the use of the information contained herein. All information contained herein is subject to change without notice. Customers should obtain and verify the latest relevant information before placing orders for Qorvo products. The information contained herein or any use of such information does not grant, explicitly or implicitly, to any party any patent rights, licenses, or any other intellectual property rights, whether with regard to such information itself or anything described by such information. **THIS INFORMATION DOES NOT CONSTITUTE A WARRANTY WITH RESPECT TO THE PRODUCTS DESCRIBED HEREIN, AND QORVO HEREBY DISCLAIMS ANY AND ALL WARRANTIES WITH RESPECT TO SUCH PRODUCTS WHETHER EXPRESS OR IMPLIED BY LAW, COURSE OF DEALING, COURSE OF PERFORMANCE, USAGE OF TRADE OR OTHERWISE, INCLUDING THE IMPLIED WARRANTIES OF MERCHANTABILITY AND FITNESS FOR A PARTICULAR PURPOSE.**

Without limiting the generality of the foregoing, Qorvo products are not warranted or authorized for use as critical components in medical, life-saving, or life-sustaining applications, or other applications where a failure would reasonably be expected to cause severe personal injury or death.

© 2022 Qorvo US, Inc. All rights reserved. This document is subject to copyright laws in various jurisdictions worldwide and may not be reproduced or distributed, in whole or in part, without the express written consent of Qorvo US, Inc.

Looking for pricing, stock, or lifecycle information?

Click below to explore more details on WIN SOURCE:

 [View QPA1013D on WIN SOURCE](#)

 [Qorvo US Inc. Information](#)

Optimize Your Supply Chain with WIN SOURCE Solutions

-  Global Sourcing Solution
-  Obsolete Management
-  Cost Control Management
-  Shortage Management
-  Alternative Solution
-  Excess Inventory Management