

CONFIGURATION TABLE (SEE NOTE 6.1)						
PART NUMBER	C MIN [pF]	C MAX [pF]	TC [PPM/°C]	Q MIN. @ 1 MHz	MARKING COLOR	ALTERNATE COLOR
JR030	1.5	3.0 +50% / -0%	0 ± 200	500	BLACK	BLACK & GREEN
JR060	2.0	6.0 +50% / -0%	0 ± 300	500	BLUE	BLUE & GREEN
JR100	2.0	10.0 +100% / -0%	0 ± 300	500	WHITE	WHITE & GREEN
JR150	3.0	15.0 +100% / -0%	0 ± 500	500	PINK	PINK & GREEN
JR200	4.5	20.0 +100% / -0%	0 ± 500	500	RED	RED & GREEN
JR300	5.5	30.0 +100% / -0%	-1500 ± 1000	200	ORANGE	ORANGE & GREEN
JR400	8.0	40.0 +100% / -0%	-1500 ± 1000	200	YELLOW	GREEN OR YELLOW & GREEN
JR500	8.0	50.0 +100% / -0%	-1500 ± 1000	200	GREEN	GREEN & GREEN

REVISION HISTORY				
ECO#	ZONE	REV	DESCRIPTION	APPROVED
		-	INITIAL ACAD RELEASE	VK 02/10/94
1607	ALL	A	SPECS MATCHED TO CURRENT SALES BROCHURES (NOTES 3.2 & 5.1)	EC 05/15/17
	ALL	B	REMOVED JR080	MI 03/23/22

**NOTES:**

- INTERPRET DRAWING PER ANSI Y14.5M-1994.
- [ALTERNATE DIMENSIONS]** ARE IN MILLIMETERS.
- ELECTRICAL SPECIFICATIONS:
  - CAPACITANCE RANGE: *SEE CONFIGURATION TABLE.*
  - DC WORKING VOLTAGE AT MAX. RATED CAPACITANCE: 125 [VOLTS].
  - DC WITHSTANDING VOLTAGE AT MAX RATED CAPACITANCE: 220 [VOLTS].
  - Q FACTOR AT 1 [MHz] AND MAX RATED CAPACITANCE: *SEE CONFIGURATION TABLE.*
  - INSULATION RESISTANCE: 10<sup>4</sup> [MEGAOHMS] AT 25°C.
  - TEMPERATURE COEFFICIENT: *SEE CONFIGURATION TABLE.*
  - SELF RESONANT FREQUENCY MEASURED AT MAX RATED CAPACITANCE
- MECHANICAL SPECIFICATIONS:
  - TUNING TORQUE: 0.14 [in·oz] TO 1.00 [in·oz].
  - ALL PARTS FURNISHED ON 12 [mm] TAPE AND REEL; 1000 PIECES PER REEL.
- ENVIRONMENTAL:
  - OPERATING TEMPERATURE: -40°C TO +85°C.
  - RoHS COMPLAINT.
- MISCELLANEOUS:
  - IN ORDER TO PROVIDE THE HIGHEST LEVELS OF SERVICE, KNOWLES RESERVES THE RIGHT TO SUPPLY EQUIVALENT PRODUCTS WHERE SPECIFICATIONS ARE EQUIVALENT OR ENHANCED. THIS INCLUDES SUBSTITUTION OF JR500 TO JR400 AND HV SUFFIX FOR STANDARDS PARTS.

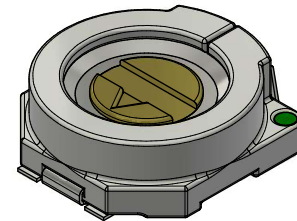

ISO VIEW  
SCALE 20 : 1

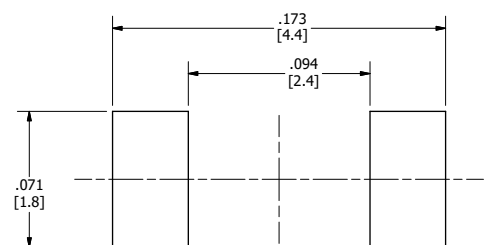
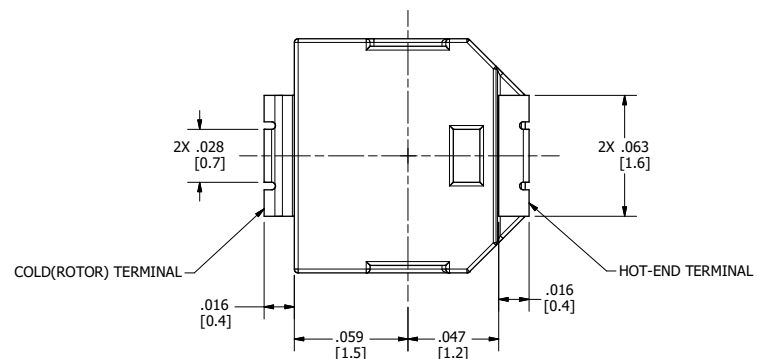
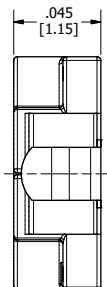
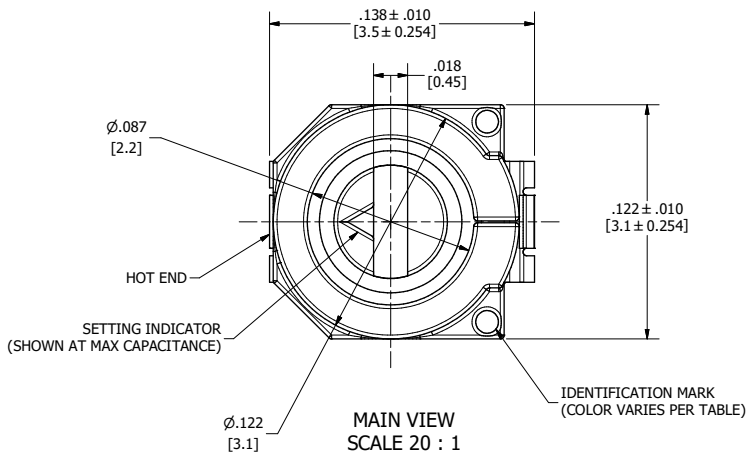

**SUGGESTED FOOTPRINT**  
SOLDER PASTE THICKNESS OF 0.15 [mm] RECOMMENDED  
SCALE 20 : 1

MATERIAL	N/A	DRAWN	E. CONTRERAS	5/15/2017	 DL-Johanson MFG-Novacap-Syter-Voltronics	<b>VOLTRONICS</b> THE TRIMMER CAPACITOR COMPANY 2777 ROUTE 20 EAST CAZENOVIA, NEW YORK 13035			
FINISH	N/A	CHECKED				<b>OUTLINE DRAWING FOR JRxxx SERIES</b>			
TOLERANCES	XX ± XXX ±.008 XXXX ± X° ± 1° X.X° ± 0.1°	SURFACE FINISH	32	QUALITY ASSURANCE		SIZE	CAGE CODE	PART NUMBER	REV
3RD ANGLE PROJECTION		ENGINEERING	A. DIAB	5/15/2017		C	55153	JRxxx	B
		CUSTOMER PART NUMBER				SCALE	PER VIEW	DWG NO.	V-7586
		INVENTOR 2014 GENERATED DWG							SHEET 1 OF 2

4

3

2

1

SECTION A-A  
SCALE 8: 1

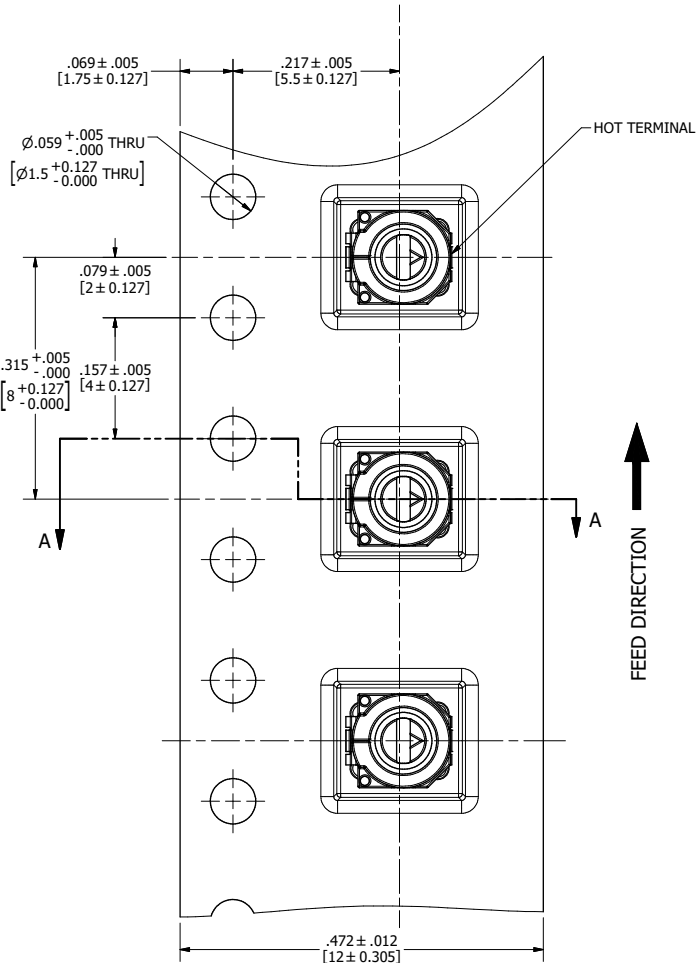
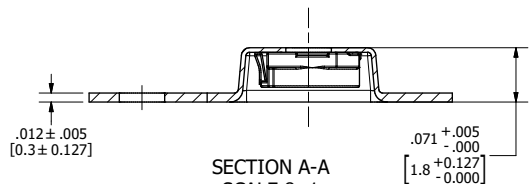

CARRIER TAPE DETAIL  
SCALE 8: 1

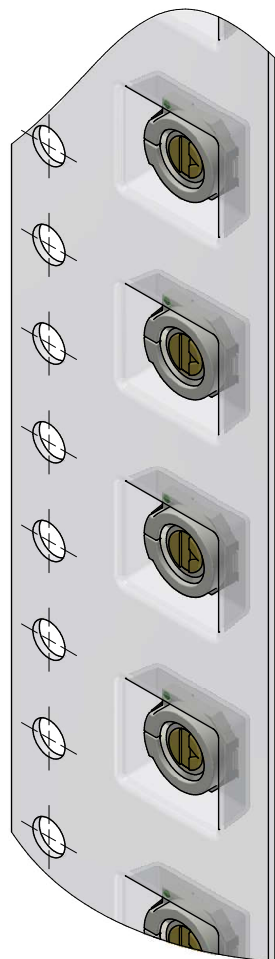

CARRIER TAPE  
ISO VIEW  
SCALE 8: 1

**HANDLING/STORAGE PRECAUTIONS:**

- i.- DO NOT USE FLOW SOLDERING.
- ii.- DO NOT APPLY SOLDER OR FLUX TO ANY PARTS BUT TERMINAL
- iii.- WHEN USING SOLDERING IRON, THE SOLDERING IRON SHOULD NOT COME IN CONTACT WITH THE HOUSING OF THE CAPACITOR.
- iv.- PLEASE REFER TO SOLDER RECOMMENDATIONS CHART.
- v.- NO-CLEAN METHOD IS PREFERRED OVER SOLVENT WASHING. EXPERIMENT WITH SAMPLES BEFORE WASHING BY SOLVENTS.
- v.- DO NOT APPLY LOCKING SPRAY OR PAINT TO TRIMMER. ELECTRIC SPECIFICATIONS MAY BE AFFECTED ADVERSELY.
- vi.- PRODUCT CONTAINS LUBRICATION OIL. LUBRICATION LEAKS WILL NOT AFFECT PRODUCT SOLDERABILITY.
- vii.- USE OF CERAMIC SCREWDRIVERS IS RECOMMENDED FOR TUNING.
- viii.- DO NOT APPLY AXIAL LOAD DURING TUNING IN EXCESS OF 0.3[lbf]/1.5[N].
- ix.- KEEP PARTS OUT OF DIRECT SUNLIGHT EXPOSURE. STORE PARTS IN DUST-FREE ENVIRONMENT.

**SOLDERING RECOMMENDATIONS**

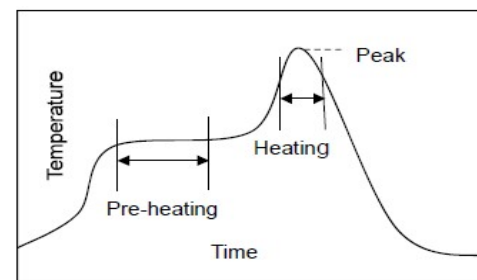

**STANDARD LEAD-FREE SOLDERING PROFILE**

STAGE	SAC305 SOLDER	EUTECTIC SOLDER
PRE-HEATING	TEMPERATURE: 150[°C] - 180[°C] TIME: 60 - 120 SECONDS	TEMPERATURE: 120[°C] - 150[°C] TIME: 60 - 120 SECONDS
HEATING	TEMPERATURE: 220[°C] MIN. TIME: 30 - 60 SECONDS	TEMPERATURE: 183[°C] MIN. TIME: 30 - 60 SECONDS
PEAK HEAT	TEMPERATURE: 265[°C] TIME: 3 SECONDS MAX	TEMPERATURE: 265[°C] TIME: 3 SECONDS MAX
REFLOW CYCLES	2 TIMES MAX	2 TIMES MAX
SOLDERING IRON		
SPEC	TEMPERATURE 400[°C] MAX TIME: 3 SECONDS MAX	

**knowles** VOLTRONICS  
 THE TRIMMER CAPACITOR COMPANY  
 2250 NORTHWOOD DRIVE  
 SALISBURY, MARYLAND 21801

SIZE C	CAGE CODE 55153	PART NUMBER JRxxx	REV B
SCALE PER VIEW	DWG NO. V-7586	SHEET 2 OF 2	

## Looking for pricing, stock, or lifecycle information?

Click below to explore more details on WIN SOURCE:

 [View JR060 on WIN SOURCE](#)

 [Knowles Voltronics](#) Information

## Optimize Your Supply Chain with WIN SOURCE Solutions

-  Global Sourcing Solution
-  Obsolete Management
-  Cost Control Management
-  Shortage Management
-  Alternative Solution
-  Excess Inventory Management