



REFLECTIONLESS

High Pass Filter

XHF2-1162+

Mini-Circuits

50Ω 11.6 to 30 GHz

THE BIG DEAL

- Match to 50Ω in the stop band, eliminates undesired reflections
- Cascadable
- Excellent Power handling
- Temperature stable, up to +105°C
- Small size, 2 x 2 mm
- Protected by US Patent No. 8,392,495



Generic photo used for illustration purposes only

CASE STYLE: MC1630-1

+RoHS Compliant

The +Suffix identifies RoHS Compliance. See our website for methodologies and qualifications

APPLICATIONS

- Wi-Fi
- WiMax
- Microwave Radio
- Military & Space

PRODUCT OVERVIEW

Mini-Circuits' XHF2-1162+ reflectionless filter employs a novel filter topology which absorbs and terminates stop band signals internally rather than reflecting them back to the source. This new capability enables unique applications for filter circuits beyond those suited to traditional approaches. Traditional filters are reflective in the stop band, sending signals back to the source at 100% of the power level. These reflections interact with neighboring components and often result in inter-modulation and other interferences. Reflectionless filters eliminate stop band reflections, allowing them to be paired with sensitive devices and used in applications that otherwise require circuits such as isolation amplifiers or attenuators.

KEY FEATURES

Feature	Advantages
Easy integration with sensitive reflective components, e.g. mixers, multipliers	Reflectionless filters absorb unwanted signals falling in filter stopband, preventing reflections back to the source. This reduces generation of additional unwanted signals without the need for extra components like attenuators, improving system dynamic range and saving board space.
Enables stable integration of wideband amplifiers	Because reflectionless filters maintain good impedance in the stopband; they can be integrated with high gain, wideband amplifiers without the risk of creating instabilities in these out of band regions.
Cascadable	Reflectionless filters can be cascaded in multiple sections to provide sharper and higher attenuation, while also preventing any standing waves that could affect passband signals. Low & highpass filters can be cascaded to realize bandpass filters.
Excellent power handling in a tiny surface mount device	High power handling extends the usability of these filters to the transmit path for inter-stage filtering.
Small size, 2x2mm QFN-Style	Allows replacement of filter/attenuator pairs with a single reflectionless filter, saving board space.
Excellent repeatability of RF performance	Through semiconductor IPD process, X-series filters are inherently repeatable for large volume production.
Operating temperature up to +105 °C	Suitable for operation close to high power components.

IPD - Integrated Passive Device, is a GaAs semiconductor process

REV. C
 ECO-021591
 XHF2-1162+
 MCL NY
 240422





REFLECTIONLESS

High Pass Filter

XHF2-1162+

Mini-Circuits

50Ω 11.6 to 30 GHz

ELECTRICAL SPECIFICATIONS¹ AT +25°C

Parameter	F#	Frequency (MHz)	Min.	Typ.	Max.	Unit	
Stop Band	Rejection	DC - 2500	—	6.9	—	dB	
		F' - F1	2500 - 8700	12.0	13.6		
	Frequency Cut-off	F2	10400	—	2.9	—	
	VSWR	DC - F'	DC - 2500	—	2.7	—	:1
		F' - F1	2500 - 8100	—	1.8	—	
Pass Band	Insertion Loss	F3 - F4	11600 - 20000	—	1.6	—	dB
		F4 - F5	20000 - 30000	—	1.0	—	
	VSWR	F3 - F4	11600 - 20000	—	2.0	—	:1
		F4 - F5	20000 - 30000	—	1.9	—	

1. Measured on Mini-Circuits Characterization Test Board TB-883-1162+

ABSOLUTE MAXIMUM RATINGS²

Parameter	Ratings
Operating Temperature	-55°C to +105°C
Storage Temperature	-65°C to +150°C
RF Power Input, Passband (F3-F5) ³	1.26W at +25°C
RF Power Input, Stopband (DC-F3) ⁴	0.25W at +25°C

2. Permanent damage may occur if any of these limits are exceeded.

3. Passband rating derates linearly to 0.63 W at 105°C ambient

4. Stopband rating derates linearly to 0.12 W at 105°C ambient

SPECIFICATION DEFINITION

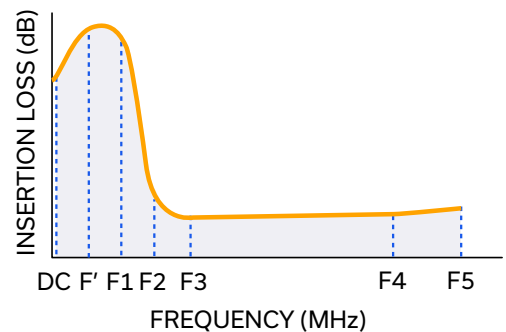



REFLECTIONLESS

High Pass Filter

XHF2-1162+

Mini-Circuits

50Ω 11.6 to 30 GHz

SIMPLIFIED SCHEMATIC AND PAD DESCRIPTION

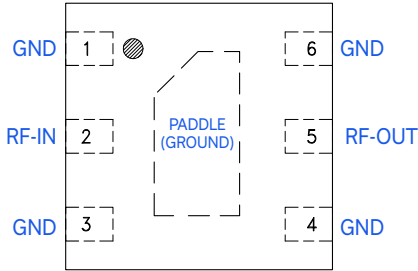
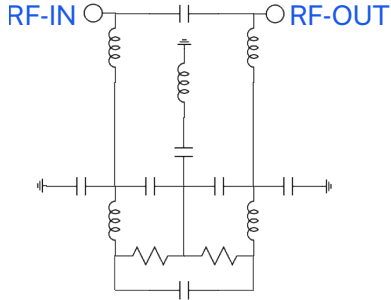

Function	Pad Number	Description
RF-IN	2	RF Input Pad
RF-OUT	5	RF Output Pad
GND	1,3,4,6, Paddle	Connected to ground

PRODUCT MARKING

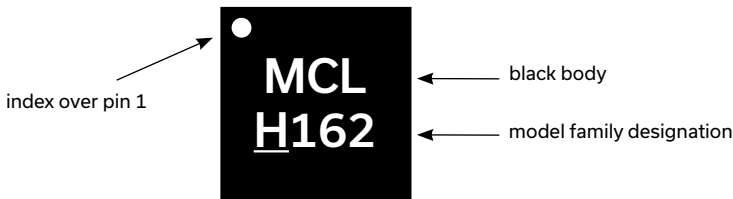

Marking may contain other features or characters for internal lot control





REFLECTIONLESS

High Pass Filter

XHF2-1162+

Mini-Circuits

50Ω 11.6 to 30 GHz

TYPICAL PERFORMANCE DATA AT +25°C

Frequency (MHz)	Insertion Loss (dB)	VSWR (:1)
100	7.15	2.72
500	8.10	2.67
1000	10.75	2.49
1500	14.39	2.27
2500	20.53	1.81
3000	19.69	1.68
4000	18.62	1.33
8700	13.80	1.70
10400	2.99	1.13
11600	1.41	1.14
12000	1.22	1.20
20000	0.98	1.74
23000	0.80	1.34

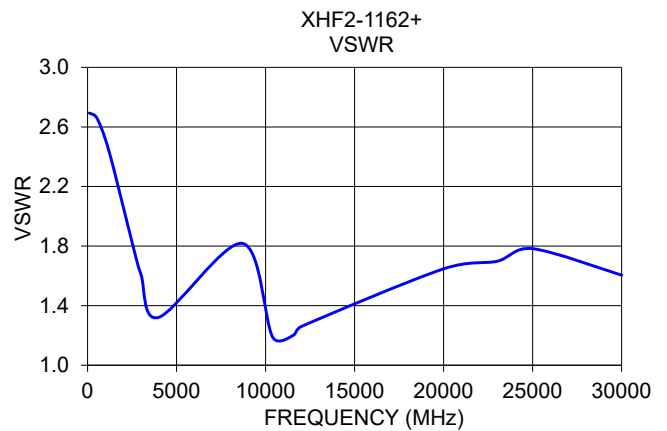
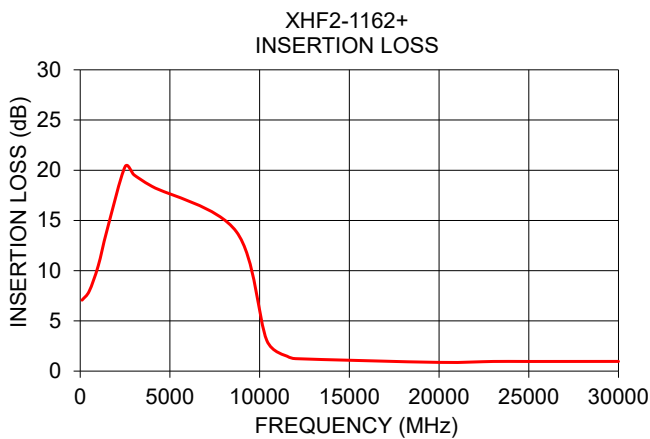



REFLECTIONLESS

High Pass Filter

XHF2-1162+

Mini-Circuits

50Ω 11.6 to 30 GHz

ADDITIONAL DETAILED TECHNICAL INFORMATION IS AVAILABLE ON OUR DASH BOARD. TO ACCESS [CLICK HERE](#)

Performance Data & Graphs	Data Graphs S-Parameter (S2P Files) Data Set (.zip file)
Case Style	MC1630-1 Plastic package, exposed paddle lead finish: matte-tin
Tape & Reel Standard quantities available on reel	F66 7" reels with 20, 50, 100, 200, 500, 1000, 2000 or 3000 devices
Suggested Layout for PCB Design	PL-499
Evaluation Board	TB-883-1162+ (without connectors) TB-883-1162C+ (with connectors) B20-118-F1+ connector sold separately
Environmental Ratings	ENV82

ESD RATING

Human body model (HBM): Class 1A (250 to <500 V) in accordance with ANSI/ESD 5.1-2001

NOTES

- A. Performance and quality attributes and conditions not expressly stated in this specification document are intended to be excluded and do not form a part of this specification document.
- B. Electrical specifications and performance data contained in this specification document are based on Mini-Circuit's applicable established test performance criteria and measurement instructions.
- C. The parts covered by this specification document are subject to Mini-Circuits standard limited warranty and terms and conditions (collectively, "Standard Terms"); Purchasers of this part are entitled to the rights and benefits contained therein. For a full statement of the standard terms and the exclusive rights and remedies thereunder, please visit Mini-Circuits' website at www.minicircuits.com/MCLStore/terms.jsp



Looking for pricing, stock, or lifecycle information?

Click below to explore more details on WIN SOURCE:

 [View XHF2-1162+ on WIN SOURCE](#)

 [Mini-Circuits Information](#)

Optimize Your Supply Chain with WIN SOURCE Solutions

-  Global Sourcing Solution
-  Obsolete Management
-  Cost Control Management
-  Shortage Management
-  Alternative Solution
-  Excess Inventory Management