

MGA-515844-99 5.1 – 5.8 GHz 25W High Efficiency Linear Power Amplifier

Features:

- 16 dB Gain
- 44 dBm P_{-3dB}
- 35 dBm Linear Pout @ 2.5% EVM (802.11 64QAM)
- 20% Efficiency at 35 dBm Linear Output Power
- Fully Matched Input and Output for Easy Cascade
- + 28V Bias Voltage
- Surface Mount Package with RoHS Compliance
- MTTF > 100 years @ 85°C ambient temperature

Applications:

- Telemetry
- Point-To-Point Radio Applications

Description:

The MGA-515844-99 is a power amplifier with the State-of-the-Art linear power-added-efficiency between 5.1 GHz and 5.8 GHz frequency band. Based on advanced robust GaN device technology, the power-added-efficiency of this power amplifier is over 50% at 25 watts. At a linear burst power of 4W with 2.5% EVM and ACPR better than -38 dBc the efficiency is 20%. The modulation test pattern is 802.16x 64QAM. The high efficiency power amplifier has excellent reliability. Ideal applications include telemetry systems for driver and the output power stage, base stations back-bone, wireless infrastructures and access points. It also can be used for PTP (Point-To-Point) radio applications for this band.

Typical RF Performance: $V_{ds}=28V, V_{gs}=-2.3V, I_{dq}=325mA, T_a=25\text{ }^\circ\text{C}, Z_0=50\text{ ohm}$

Parameter	Units	Typical Data
Frequency Range	MHz	5100-5800
Gain (Typ)	dB	16
Gain Flatness (Typ)	+/-dB	1.0
Input Return Loss	dB	10
Output Return Loss	dB	12
Output P3dB	dBm	44
Pout @ 2.5% EVM	dBm	35
Operating Current Range	mA	<2,000
Thermal Resistance	°C /W	2.8

MGA-515844-99

5.1 – 5.8 GHz 25W High Efficiency
Linear Power Amplifier

Typical RF Performance: $V_{ds}=28.0V, V_{gs}=-2.3V, I_{dq}=325mA, Z_0=50\text{ ohm}, T_a=25\text{ }^\circ\text{C}$

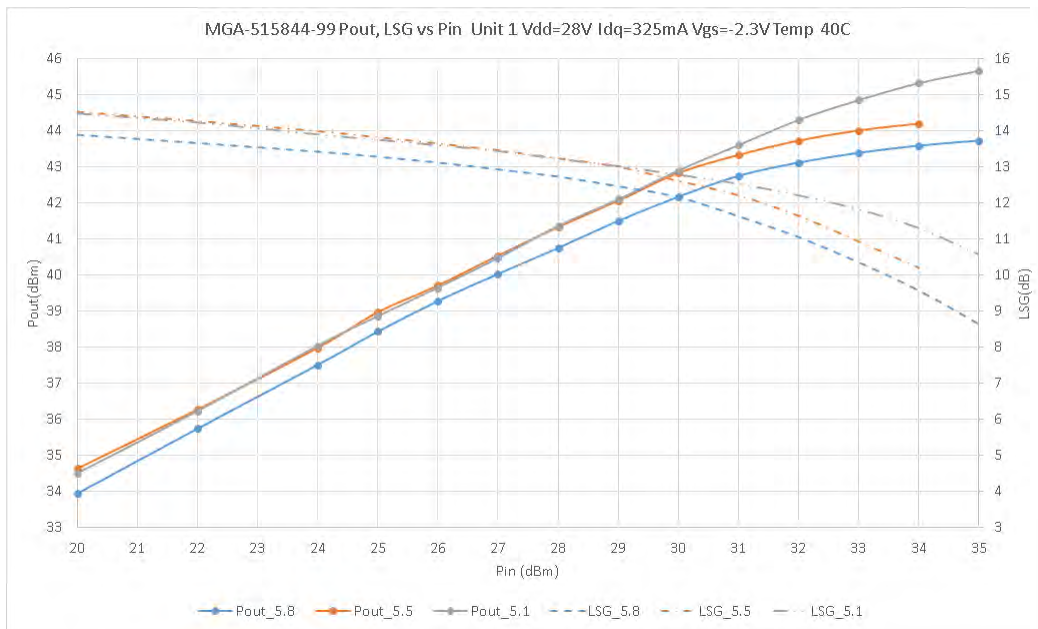
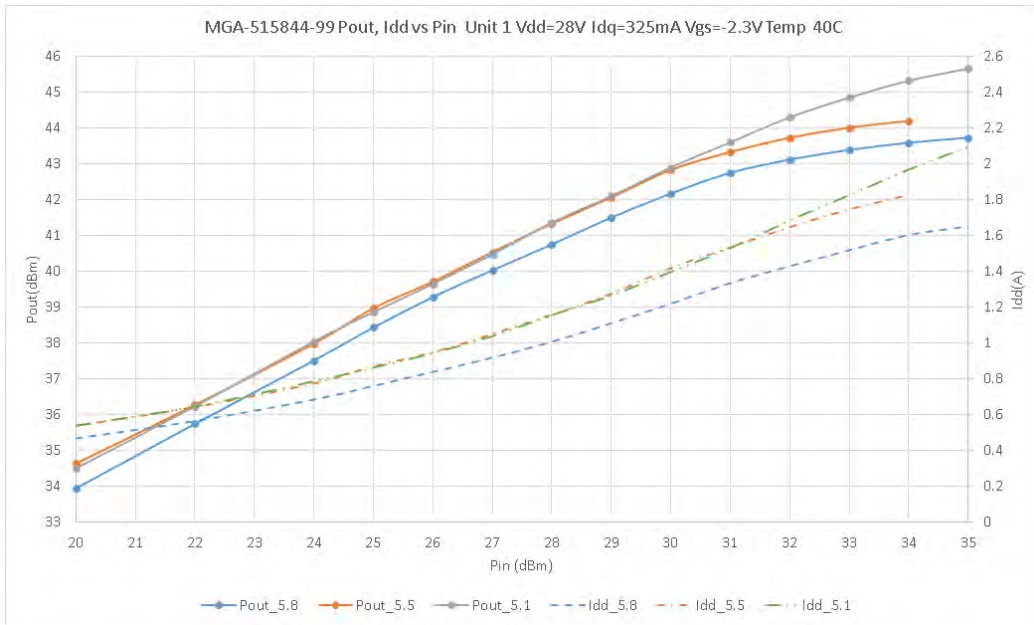

Absolute Maximum Ratings: $(T_a = 25\text{ }^\circ\text{C})^*$

SYMBOL	PARAMETERS	UNITS	ABSOLUTE MAXIMUM
V _{ds}	Drain-Source Voltage	V	50
V _{gs}	Gate-Source Voltage	V	10
I _d	Drain Current	A	6
I _g	Gate Current	mA	7
P _{diss}	DC Power Dissipation	W	50
Pin max	RF Input Power	dBm	+33
T _{ch}	Channel Temperature	°C	225
T _{stg}	Storage Temperature	°C	-55 to 150

*Operation of this device above any one of these parameters may cause permanent damage.

Mechanical Information: *This Package is RoHS compliant*

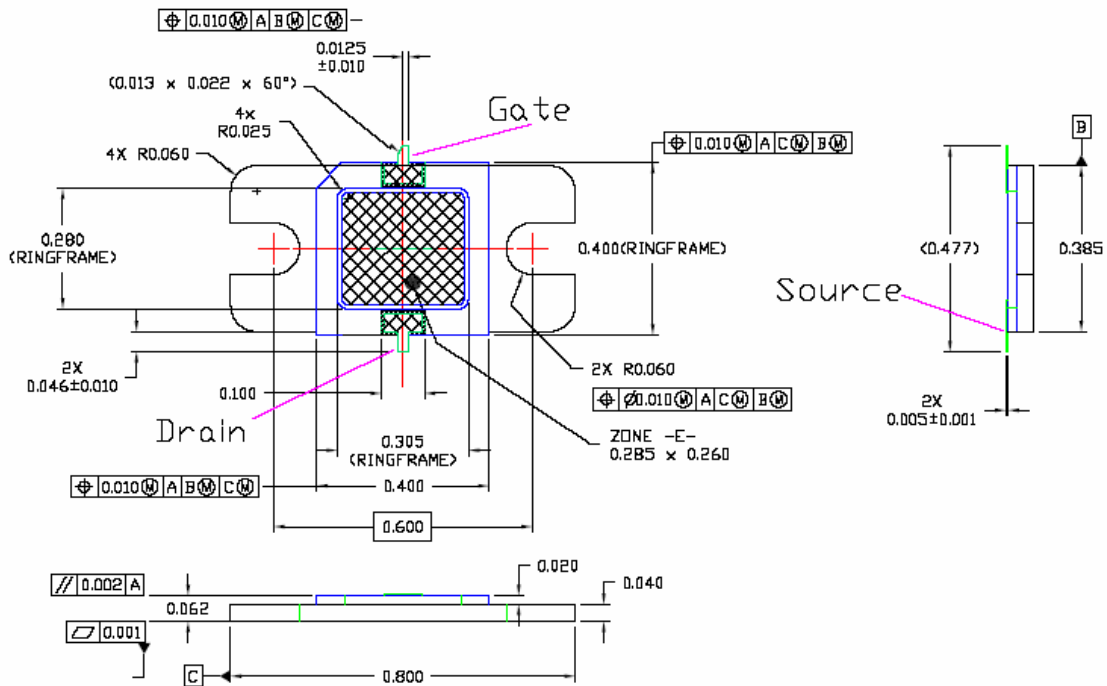

All dimensions are in inches

Pin Designation (Top View)	
Pin Number	Description
Pin 1 (Chamfer)	Gate
Pin 2	Drain
Mounting Surface	GND

MGA-515844-99

5.1 – 5.8 GHz 25W High Efficiency
Linear Power Amplifier

Demo Board Layout

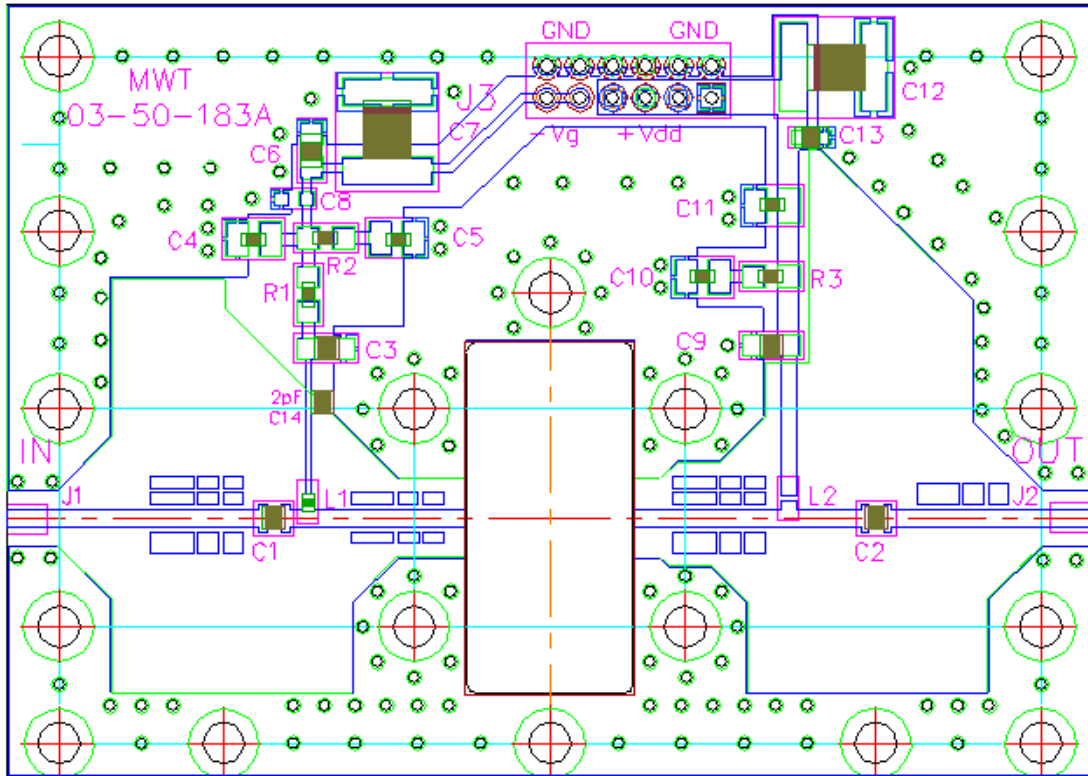

MGA-515844-99

5.1 – 5.8 GHz 25W High Efficiency
Linear Power Amplifier

Bill of Material

Item	Quantity	Description	Vendor P/N	MwT P/N	Ref No.
1	1	Connector , 12 PIN	DF11-12DP-20SA		P1
2	1	coil 3 turn	3-5038-A	03-02-302	L2
3	1	coil 8.2 nH	0402DC-8N2X-R		L1
4	4	Capacitor .1 uF	0603YC104KAT2A	03-02-593	C4,5,10&11
5	2	Capacitor 1000 pF	C4520X7R3A102K	03-02-603	C6,13
6	1	Capacitor 2 pF	ML03512R08AT2A	03-02-304	C14
7	2	Capacitor 2.2 uF	T491B225KD35A1	03-02-643	C7,C12
8	4	Capacitor 3.9 pF	ATC100A3R9BCA150XC	03-02-604	C1,2,3&9
9	2	Resistor surface mount 51 ohms	ERJ-2GEJ510X	03-02-308	R2,3
10	1	Resistor surface mount 18 ohms	ERJ-2GEJ180X	03-02-309	R1

Electrical Schematics

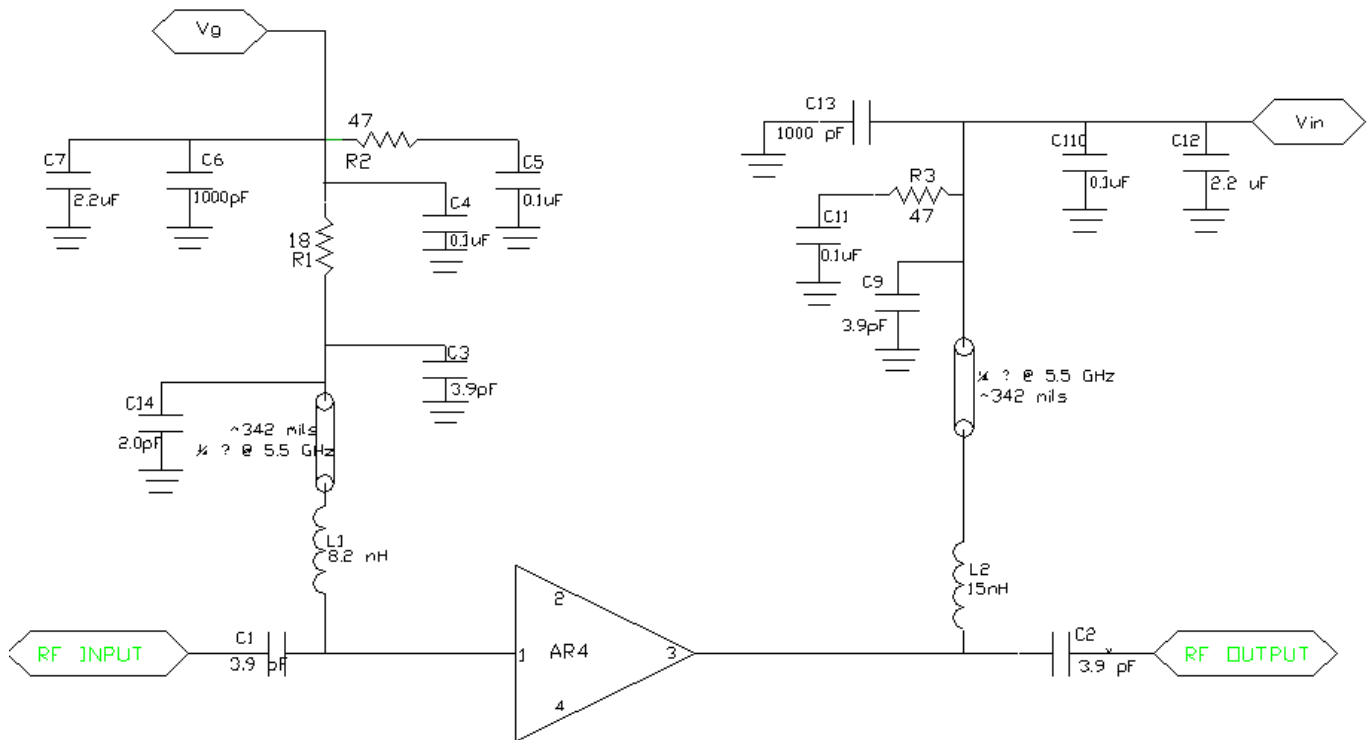

MGA-515844-99

**5.1 – 5.8 GHz 25W High Efficiency
Linear Power Amplifier**

Contact Information

For additional information please visit www.cmlmicro.com or contact a sales office.

Europe	America	Asia
<ul style="list-style-type: none">• Maldon, UK• Tel +44 (0) 1621 875500• sales@cmlmicro.com	<ul style="list-style-type: none">• Winston-Salem, NC• Tel +1 336 744 5050• us.sales@cmlmicro.com	<ul style="list-style-type: none">• Singapore• Tel +65 6288129• sg.sales@cmlmicro.com

Although the information contained in this document is believed to be accurate, no responsibility is assumed by CML for its use. The product and product information is subject to change at any time without notice. CML has a policy of testing every product shipped using calibrated test equipment to ensure compliance with product specification.

© 2018 CML Microsystems Plc

Looking for pricing, stock, or lifecycle information?

Click below to explore more details on WIN SOURCE:

 [View MGA-515844-99](#) on WIN SOURCE

 [CML Microcircuits](#) Information

Optimize Your Supply Chain with WIN SOURCE Solutions

-  Global Sourcing Solution
-  Obsolete Management
-  Cost Control Management
-  Shortage Management
-  Alternative Solution
-  Excess Inventory Management