

## GaAs HEMT MMIC MODULATOR DRIVER AMPLIFIER, DC - 43 GHz

### Typical Applications

This HMC-AUH232 is ideal for:

- 40 Gb/s Lithium Niobate/ Mach Zender Fiber Optic Modulators
- Broadband Gain Block for Test & Measurement Equipment
- Broadband Gain Block for RF Applications
- Military & Space

### Features

- Small Signal Gain: 12 dB
- Output Voltage: up to 8V pk-pk
- Single-Ended I/Os
- High Speed Performance: 46 GHz 3 dB Bandwidth
- Low Power Dissipation: 0.9 W
- Small Die Size: 2.1 x 1.70 x 0.1 mm

### Functional Diagram

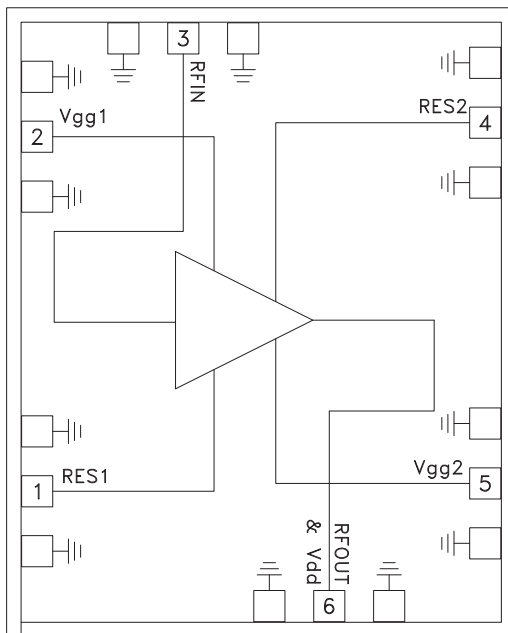

### General Description

The HMC-AUH232 is a GaAs MMIC HEMT Distributed Driver Amplifier die which operates between DC and 43 GHz and provides a typical 3 dB bandwidth of 46 GHz. The amplifier provides 12 dB of small signal gain while requiring only 180 mA from a +5V supply. The HMC-AUH232 exhibits very good gain and phase ripple to 40 GHz, and can output up to 8V peak-to-peak with low jitter, making it ideal for use in broadband wireless, fiber optic communication and test equipment applications. The amplifier die occupies less than 3.6 mm<sup>2</sup> which facilitates easy integration into Multi-Chip-Modules (MCMs). The HMC-AUH232 requires external bias-tee as well as off-chip blocking components and bypass capacitors for the DC supply lines. A gate voltage adjust, Vgg2 is provided for limited gain adjustment, while Vgg1 adjusts the bias current for the device.

### Electrical Specifications\*, T<sub>A</sub> = +25 °C

Parameter	Min.	Typ.	Max.	Units
Frequency Range	DC - 43			GHz
Small Signal Gain	0.5 - 5.0 GHz	12	14	dB
	35 - 45 GHz	10	12.5	dB
Input Return Loss		10		dB
Output Return Loss		8.5		dB
Supply Current		180	225	mA
3 dB Bandwidth	43	46		GHz
Gain Ripple (5 to 35 GHz)		±0.6	±1	dB
Group Delay Variation <sup>(1)</sup>	0.5 - 5.0 GHz		±14	ps
	5 - 30 GHz		±10	ps
	30 - 45 GHz		±22	ps

Information furnished by Analog Devices is believed to be accurate and reliable. However, no responsibility is assumed by Analog Devices for its use, nor for any infringements of patents or other rights of third parties that may result from its use. Specifications subject to change without notice. No license is granted by implication or otherwise under any patent or patent rights of Analog Devices. Trademarks and registered trademarks are the property of their respective owners.

For price, delivery, and to place orders: Analog Devices, Inc., One Technology Way, P.O. Box 9106, Norwood, MA 02062-9106 Phone: 781-329-4700 • Order online at [www.analog.com](http://www.analog.com) Application Support: Phone: 1-800-ANALOG-D

## GaAs HEMT MMIC MODULATOR DRIVER AMPLIFIER, DC - 43 GHz

### Electrical Specifications (Continued)\*

Parameter	Min.	Typ.	Max.	Units
10% to 90% Rise / Fall Time <sup>[2]</sup>		6 - 12		ps
Output Voltage Level <sup>[3]</sup>		8		V <sub>P-P</sub>
Additive jitter (RMS)		0.4		ps
1 dB Output Gain Compression Point at 20 GHz		16.5		dBm
Output Power	20 GHz @ Pin= 15 dBm <sup>[4]</sup>	22	22	dBm
	40 GHz @ Pin= 15 dBm <sup>[4]</sup>	17	19.5	dBm
Power Dissipation		0.9	1.25	W
Noise Figure	5 GHz		5.4	dB
	10 & 15 GHz		4.2	dB
	20 GHz		4.6	dB
	25 GHz		5.4	dB
	30 GHz		8.3	dB
	35 GHz		7.4	dB
	40 GHz		9.1	dB

[1] Measured with a 1 GHz aperture

[2] Measurement limited by rise/fall time of input reference signal

[3] With a 2.7 V<sub>P-P</sub> input signal

\*Unless otherwise indicated, all measurements are from probed die

[4] Verified at RF on-wafer probe. V<sub>gg1</sub> is adjusted until the drain current is 200 mA and V<sub>gg2</sub>= 1.5 V. The drain voltage is applied through the RF output port using a bias tee with 5 volts on the bias Tee.

### Recommended Operating Conditions

Parameter	Symbol	Min.	Typ.	Max.	Units
Positive Supply Voltage	V <sub>D</sub>		5	6	V
Positive Supply Current	I <sub>D</sub>	150	180	225	mA
RF Input Power			12	16	dBm
Bias Current Adjust	V <sub>gg1</sub>	-1.5	-0.2		V
Output Voltage Adjust	V <sub>gg2</sub>	0	1.5	2	V
Operating Temperature	T <sub>OP</sub>	0	25	85	°C
Power Dissipation	P <sub>D</sub>		0.9	1.25	W

### Reliability Characteristics

Parameter	Symbol	Typ.	Units
Activation Energy	E <sub>A</sub>	1.7	eV
Median time to Failure (MTF) @125 °C Channel Temperature	MTF	6 x 10 <sup>9</sup>	Hours

### Thermal Characteristics

Parameter	P <sub>DISS</sub> (W)	T <sub>BASE</sub> (°C)	T <sub>CH</sub> (°C)	R (°C/W)	MTF (Hrs)
Thermal Resistance to back side of chip	1.25	85	145	48	5.8 x 10 <sup>8</sup>
Thermal resistance to backside of carrier using 25.4 um of 84-1LMIT epoxy	1.25	85	155	56	1.8 x 10 <sup>8</sup>
Thermal Resistance to back side of chip	1.25	110	170	48	3.9 x 10 <sup>7</sup>
Thermal resistance to backside of carrier using 25.4 um of 84-1LMIT epoxy	1.25	110	180	56	1.4 x 10 <sup>7</sup>

**GaAs HEMT MMIC MODULATOR  
DRIVER AMPLIFIER, DC - 43 GHz**

**Gain vs. Frequency**

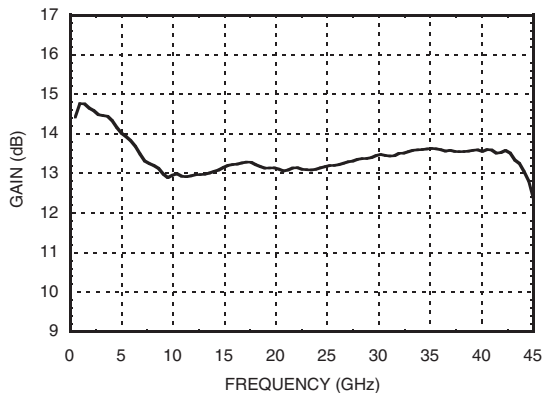

**Input Return Loss vs. Frequency**

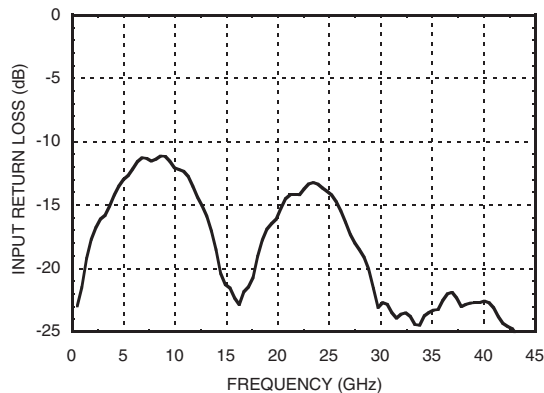

**Noise Figure vs. Frequency**

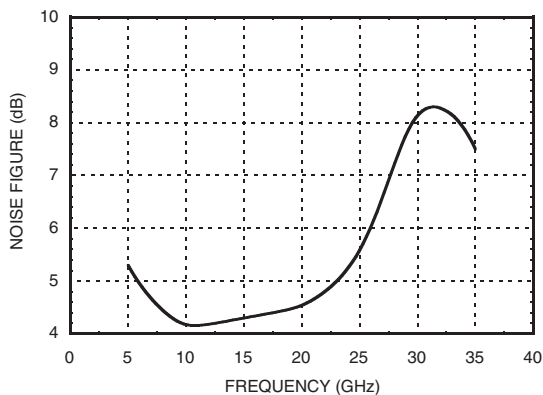

**Output Return Loss vs. Frequency**

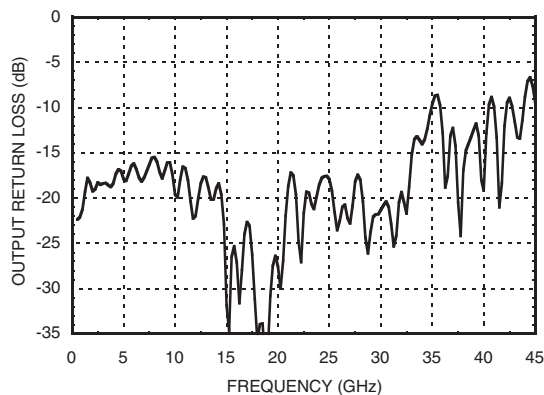

**Output Voltage Delta vs. Control Voltage**

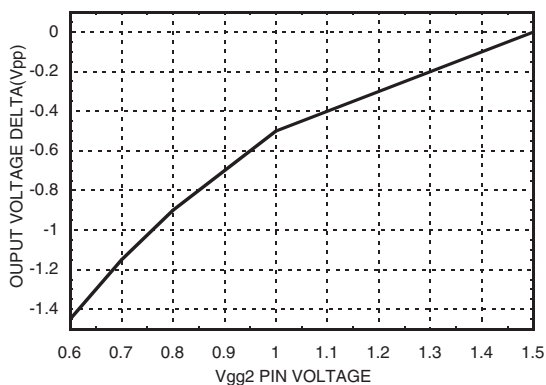

Note: Measured Performance Characteristics (Typical Performance at 25°C) V<sub>gg2</sub> = 1.5V, V<sub>dd</sub> = 5V, I<sub>dd</sub> = 200 mA (Measured data obtained from die in a test fixture unless otherwise stated)

Information furnished by Analog Devices is believed to be accurate and reliable. However, no responsibility is assumed by Analog Devices for its use, nor for any infringements of patents or other rights of third parties that may result from its use. Specifications subject to change without notice. No license is granted by implication or otherwise under any patent or patent rights of Analog Devices. Trademarks and registered trademarks are the property of their respective owners.

For price, delivery, and to place orders: Analog Devices, Inc., One Technology Way, P.O. Box 9106, Norwood, MA 02062-9106 Phone: 781-329-4700 • Order online at [www.analog.com](http://www.analog.com) Application Support: Phone: 1-800-ANALOG-D

## GaAs HEMT MMIC MODULATOR DRIVER AMPLIFIER, DC - 43 GHz

### Absolute Maximum Ratings

Drain Bias Voltage (Vdd)	+6 Vdc
Gain Bias Voltage (Vgg1)	-1.5 to 0 Vdc
Output Voltage Adjust (Vgg2)	0 to +2 Vdc
RF Input Power	+18.5 dBm
40 Gb/s Input Voltage Pk-Pk (Vpp)	3V
Thermal Resistance (channel to die bottom)	48 °C/W
Channel Temperature	180 °C
Storage Temperature	-65 to +150 °C
Operating Temperature	-55 to +110 °C



ELECTROSTATIC SENSITIVE DEVICE  
OBSERVE HANDLING PRECAUTIONS

### Input Reference Signal

PRBS=2<sup>31</sup>-1, 2.1V Input, Data rate of 40 Gb/s

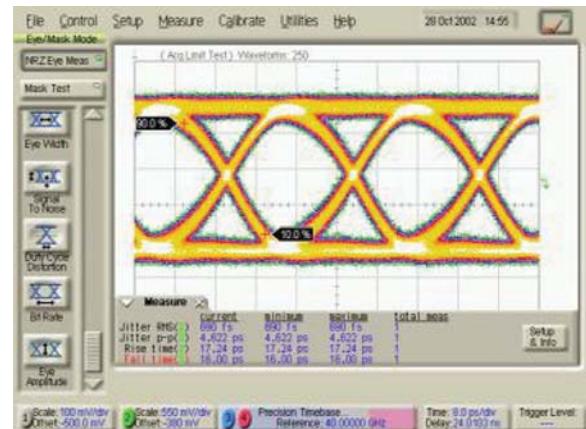
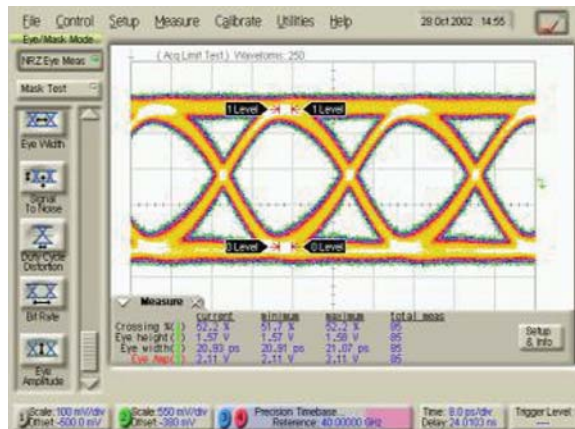

### Output Reference Signal

PRBS=2<sup>31</sup>-1, 7.3V Input, Data rate of 40 Gb/s

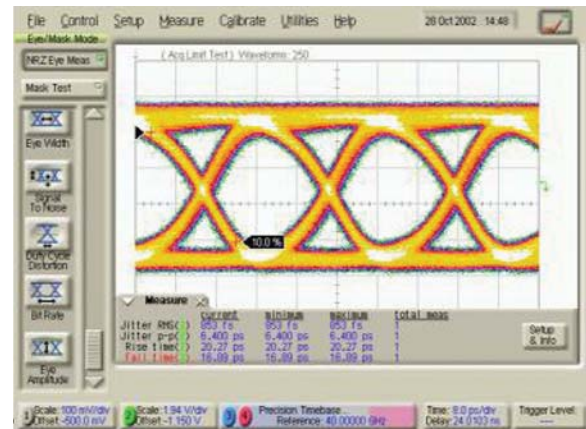
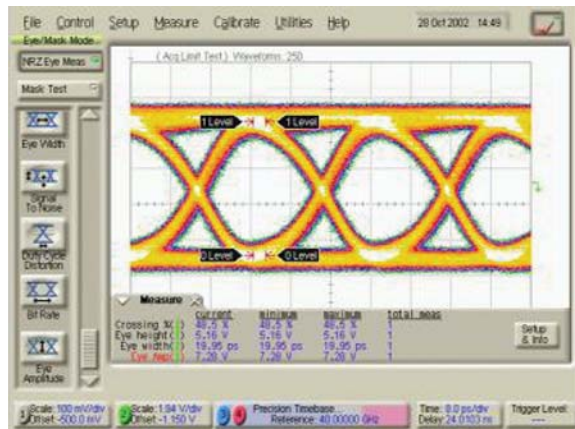

Note: Measured Performance Characteristics (Typical Performance at 25°C) (Measured data obtained from die in a test fixture unless otherwise stated)

Information furnished by Analog Devices is believed to be accurate and reliable. However, no responsibility is assumed by Analog Devices for its use, nor for any infringements of patents or other rights of third parties that may result from its use. Specifications subject to change without notice. No license is granted by implication or otherwise under any patent or other rights of Analog Devices. Trademarks and registered trademarks are the property of their respective owners.

For price, delivery, and to place orders: Analog Devices, Inc., One Technology Way, P.O. Box 9106, Norwood, MA 02062-9106 Phone: 781-329-4700 • Order online at [www.analog.com](http://www.analog.com) Application Support: Phone: 1-800-ANALOG-D

**GaAs HEMT MMIC MODULATOR  
DRIVER AMPLIFIER, DC - 43 GHz**

**Outline Drawing**

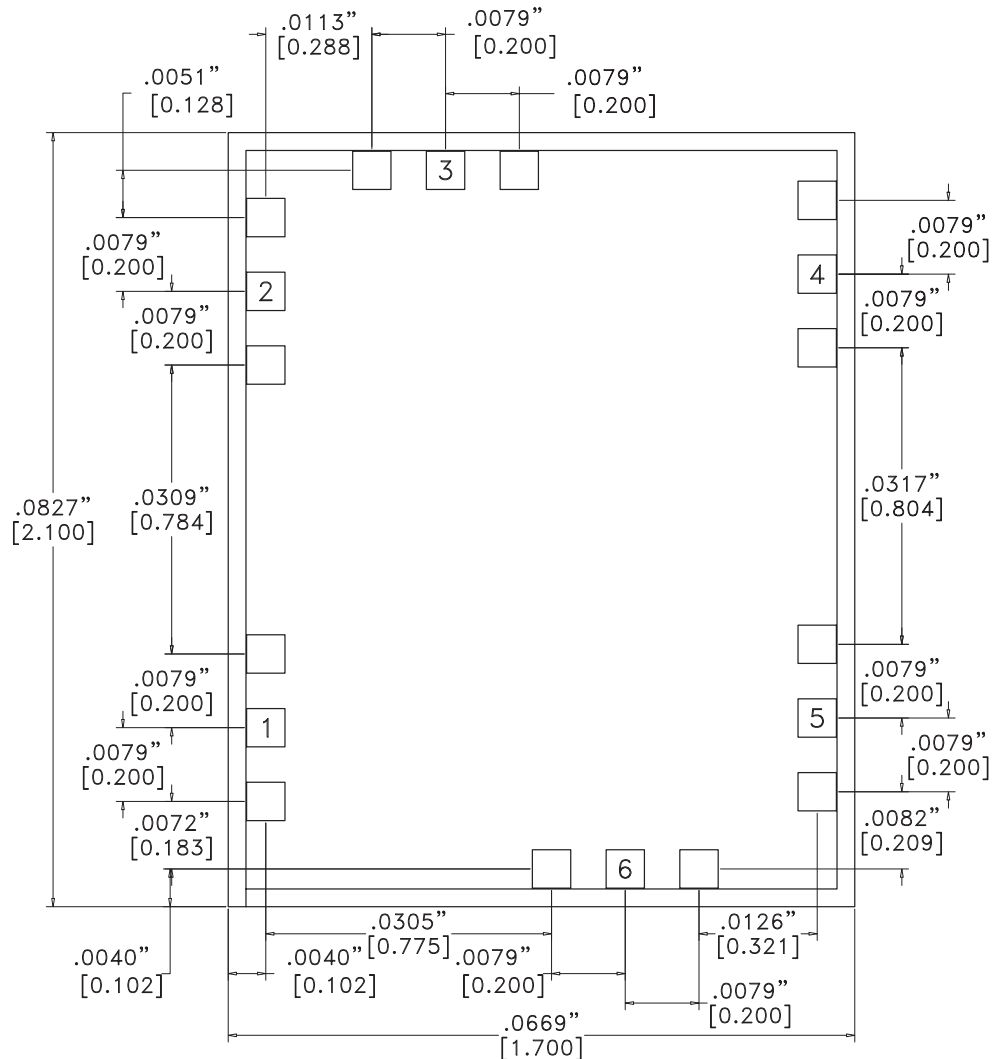

**Die Packaging Information [1]**

Standard	Alternate
GP-1 (Gel Pack)	[2]

[1] Refer to the "Packaging Information" section for die packaging dimensions.

[2] For alternate packaging information contact Hittite Microwave Corporation.

**NOTES:**

1. ALL DIMENSIONS ARE IN INCHES [MM].
2. TYPICAL BOND PAD IS .004" SQUARE.
3. BACKSIDE METALLIZATION: GOLD.
4. BACKSIDE METAL IS GROUND.
5. BOND PAD METALLIZATION: GOLD.
6. CONNECTION NOT REQUIRED FOR UNLABELED BOND PADS.
7. OVERALL DIE SIZE ±.002"

**GaAs HEMT MMIC MODULATOR  
DRIVER AMPLIFIER, DC - 43 GHz**

**Pad Descriptions**

Pad Number	Function	Description	Interface Schematic
1	RES1	DC coupled 35Ω termination.	
2	Vgg1	Gate control for amplifier. Please follow "MMIC Amplifier Biasing Procedure" application note. See assembly for required external components.	
5	Vgg2	Gate Control for amplifier. Limited gain control adjust. See Assembly Diagram for external components.	
6	Vdd & RFOUT	RF output and DC Bias (vdd) for the output stage.	
3	RFIN	DC coupled. Blocking Cap is needed.	
4	RES2	AC coupled 50Ω termination.	

**Application Circuit**

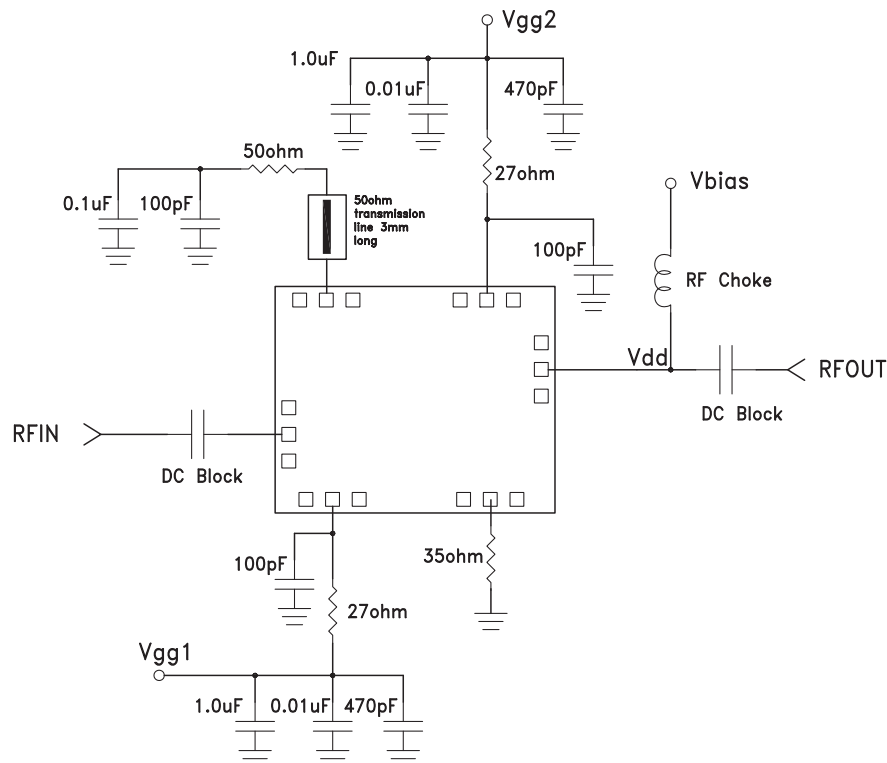

Information furnished by Analog Devices is believed to be accurate and reliable. However, no responsibility is assumed by Analog Devices for its use, nor for any infringements of patents or other rights of third parties that may result from its use. Specifications subject to change without notice. No license is granted by implication or otherwise under any patent or patent rights of Analog Devices. Trademarks and registered trademarks are the property of their respective owners.

For price, delivery, and to place orders: Analog Devices, Inc., One Technology Way, P.O. Box 9106, Norwood, MA 02062-9106 Phone: 781-329-4700 • Order online at [www.analog.com](http://www.analog.com) Application Support: Phone: 1-800-ANALOG-D



**GaAs HEMT MMIC MODULATOR  
DRIVER AMPLIFIER, DC - 43 GHz****Device Mounting**

- 1 mil diameter wire bonds are used on Vgg1 and Vgg2 connections to the capacitors and 27 $\Omega$  resistors.
- 0.5mil x 3mil ribbon bonds are used on RF connections
- Capacitors and resistors on Vgg1 and Vgg2 are used to filter low frequency, <800MHz, RF pickup
- 35 $\Omega$  and 50 $\Omega$  resistors are fabricated on a 5mil alumina substrate and should be suitable for use as a high frequency termination.
- For best gain flatness and group delay variation, eccosorb can be epoxied on the transmission line covering the center 3/4 of the transmission line length. Eccosorb may also be placed partially across the Vg1 pad and 35 $\Omega$  resistor for improved gain flatness and group delay variation.  
*(The insertion of the transmission line helps reduce low frequency, <10GHz, gain ripple)*
- Silver-filled conductive epoxy is used for die attachment  
*(Backside of the die should be grounded and the GND pads are connected to the backside metal through Vias)*

**Device Operation**

These devices are susceptible to damage from Electrostatic Discharge. Proper precautions should be observed during handling, assembly and test.

The input to this device should be AC-coupled. To provide the typical 8Vpp output voltage swing, a 2.7Vpp AC-coupled input voltage swing is required. At this output level, the device will be in 1dB to 3dB of compression.

**Device Power Up Instructions**

1. Ground the device
  2. Bring Vgg1 to -0.5V (no drain current)
  3. Bring Vgg2 to +1.5V (no drain current)
  4. Bring Vdd to +5V (150mA to 225mA drain current)  
*(Initially the drain current will rise sharply with a small drain voltage, but will flatten out as Vdd approaches 5V)*
- Vgg1 may be varied between -1V and 0V to provide the desired eye crossing point percentage  
*(i.e. 50% crosspoint) and a limited cross point control capability.*
  - Vdd may be increased to +5.5V if required to achieve greater output voltage swing.
  - Vgg2 may be adjusted between +1.5V and +0.3V to vary the output voltage swing.

**Device Power Down Instructions**

1. Reverse the sequence identified above in steps 1 through 4.

## GaAs HEMT MMIC MODULATOR DRIVER AMPLIFIER, DC - 43 GHz

### Mounting & Bonding Techniques for Millimeterwave GaAs MMICs

The die should be attached directly to the ground plane eutectically or with conductive epoxy (see HMC general Handling, Mounting, Bonding Note).

50 Ohm Microstrip transmission lines on 0.127mm (5 mil) thick alumina thin film substrates are recommended for bringing RF to and from the chip (Figure 1). If 0.254mm (10 mil) thick alumina thin film substrates must be used, the die should be raised 0.150mm (6 mils) so that the surface of the die is coplanar with the surface of the substrate. One way to accomplish this is to attach the 0.102mm (4 mil) thick die to a 0.150mm (6 mil) thick molybdenum heat spreader (moly-tab) which is then attached to the ground plane (Figure 2).

Microstrip substrates should be placed as close to the die as possible in order to minimize bond wire length. Typical die-to-substrate spacing is 0.076mm to 0.152 mm (3 to 6 mils).

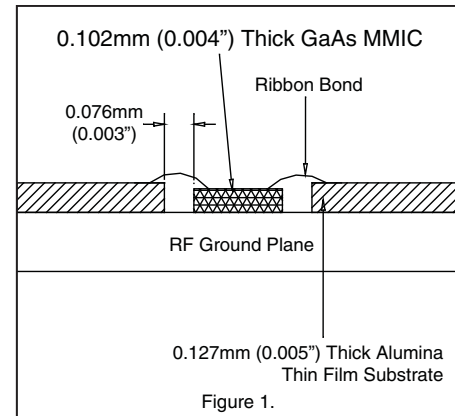

### Handling Precautions

Follow these precautions to avoid permanent damage.

**Storage:** All bare die are placed in either Waffle or Gel based ESD protective containers, and then sealed in an ESD protective bag for shipment. Once the sealed ESD protective bag has been opened, all die should be stored in a dry nitrogen environment.

**Cleanliness:** Handle the chips in a clean environment. DO NOT attempt to clean the chip using liquid cleaning systems.

**Static Sensitivity:** Follow ESD precautions to protect against ESD strikes.

**Transients:** Suppress instrument and bias supply transients while bias is applied. Use shielded signal and bias cables to minimize inductive pick-up.

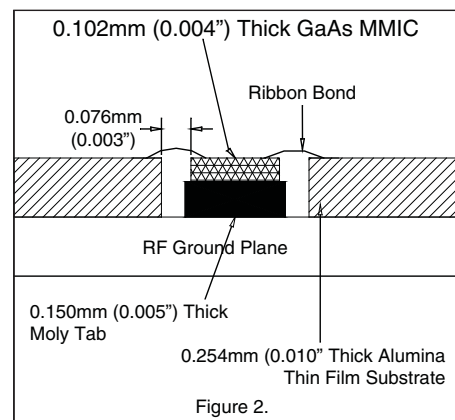

**General Handling:** Handle the chip along the edges with a vacuum collet or with a sharp pair of bent tweezers. The surface of the chip has fragile air bridges and should not be touched with vacuum collet, tweezers, or fingers.

### Mounting

The chip is back-metallized and can be die mounted with AuSn eutectic preforms or with electrically conductive epoxy. The mounting surface should be clean and flat.

**Eutectic Die Attach:** A 80/20 gold tin preform is recommended with a work surface temperature of 255 °C and a tool temperature of 265 °C. When hot 90/10 nitrogen/hydrogen gas is applied, tool tip temperature should be 290 °C. DO NOT expose the chip to a temperature greater than 320 °C for more than 20 seconds. No more than 3 seconds of scrubbing should be required for attachment.

**Epoxy Die Attach:** Apply a minimum amount of epoxy to the mounting surface so that a thin epoxy fillet is observed around the perimeter of the chip once it is placed into position. Cure epoxy per the manufacturer's schedule.

### Wire Bonding

RF bonds made with 0.003" x 0.0005" ribbon are recommended. These bonds should be thermosonically bonded with a force of 40-60 grams. DC bonds of 0.001" (0.025 mm) diameter, thermosonically bonded, are recommended. Ball bonds should be made with a force of 40-50 grams and wedge bonds at 18-22 grams. All bonds should be made with a nominal stage temperature of 150 °C. A minimum amount of ultrasonic energy should be applied to achieve reliable bonds. All bonds should be as short as possible, less than 12 mils (0.31 mm).

**GaAs HEMT MMIC MODULATOR  
DRIVER AMPLIFIER, DC - 43 GHz****Notes**

## Looking for pricing, stock, or lifecycle information?

Click below to explore more details on WIN SOURCE:

 [View HMC-AUH232 on WIN SOURCE](#)

 [Analog Devices Inc. Information](#)

## Optimize Your Supply Chain with WIN SOURCE Solutions

-  Global Sourcing Solution
-  Obsolete Management
-  Cost Control Management
-  Shortage Management
-  Alternative Solution
-  Excess Inventory Management