

### Product Overview

Qorvo's QPA4446D is a high power MMIC amplifier fabricated on Qorvo's production 0.15 um GaN on SiC process (QGaN15). It is targeted to the 37.5 - 42.5 GHz Satcom Q-V band. QPA4446D achieves 2 W linear power with 25 dBc third order intermodulation distortion products, and 18 dB small signal gain. It provides 4 W of saturated output power while achieving 25% power-added efficiency.

To simplify system integration, the QPA4446D is fully matched to 50 ohms with integrated DC blocking caps on both I/O ports. Its RF input port is DC coupled to ground for optimum ESD performance.

The QPA4446D is ideal for supporting communications and radar applications in both commercial and military markets.

The QPA4446D is 100% DC and RF tested on-wafer to ensure compliance to electrical specifications.

Lead-free and RoHS compliant

### Functional Block Diagram

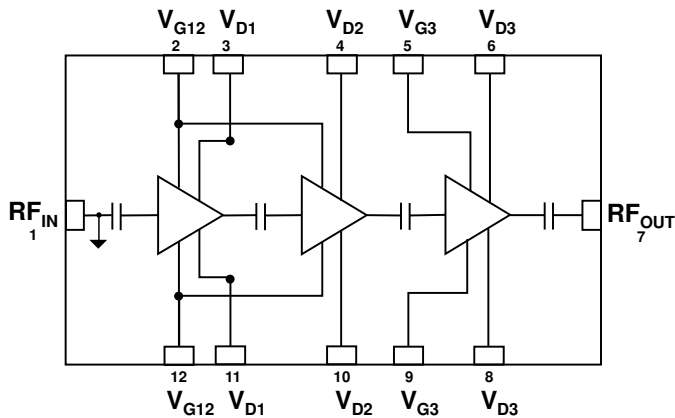

### Key Features

- Frequency Range: 37.5 – 42.5 GHz
- P<sub>SAT</sub> (P<sub>IN</sub> = 22 dBm): 36 dBm
- PAE (P<sub>IN</sub> = 22 dBm): 25 %
- IM3 (P<sub>OUT</sub>/Tone = 30 dBm): -25 dBc
- Small Signal Gain: 18 dB
- Bias: V<sub>D</sub> = 24 V, I<sub>DQ</sub> = 70 mA, V<sub>G</sub> = -2.3 V typ. range
- Die Dimensions: 3.26 x 1.49 x 0.05 mm

*Performance is typical across frequency. Please reference electrical specification table and data plots for more details.*

### Applications

- Satellite Communications

### Ordering Information

Part No.	Description
QPA4446D	4 Watt GaN PA
QPA4446DEVB	Evaluation Board for QPA4446D



### Absolute Maximum Ratings

Parameter	Value / Rang
Drain Voltage (V <sub>D</sub> )	29.5 V
Gate Voltage Range (V <sub>G</sub> )	-4 V to 0 V
Drain Current (I <sub>D1</sub> ), T <sub>BASE</sub> = 85 °C max	345 mA
Drain Current (I <sub>D2</sub> ), T <sub>BASE</sub> = 85 °C max	900 mA
Drain Current (I <sub>D3</sub> ), T <sub>BASE</sub> = 85 °C max	3450 mA
Drain Current Total (I <sub>D</sub> ), T <sub>BASE</sub> = 85 °C max	4695 mA
Gate Current (I <sub>G</sub> )	See p. 25
Power Dissipation (P <sub>DISS</sub> ), T <sub>BASE</sub> = 85 °C	18 W
Input Power (P <sub>IN</sub> ), 50 Ω, CW, V <sub>D</sub> = 24 V, I <sub>D</sub> = 140 mA, T <sub>BASE</sub> = 85 °C	31 dBm
Input Power (P <sub>IN</sub> ), 3:1 VSWR, CW, V <sub>D</sub> = 24 V, I <sub>D</sub> = 140 mA, T <sub>BASE</sub> = 85 °C	31 dBm
Mounting Temperature (30 seconds)	320 °C
Storage Temperature	-55 to +150 °C

Operation of this device outside the parameter ranges given above may cause permanent damage. These are stress ratings only, and functional operation of the device at these conditions is not implied.

### Recommended Operating Conditions

Parameter	Min	Typ.	Max	Units
Drain Voltage (V <sub>D</sub> )	20	24	24	V
Drain Current, Quiescent (I <sub>D</sub> )	70	70		mA
Drain Current, RF (I <sub>D_Drive</sub> )	See plot page 4,5,8,11,14			mA
Gate Voltage Typical Range (V <sub>G</sub> )	-1.7 to -2.9			V
Gate Current, RF (I <sub>G_Drive</sub> )	See plot page 4,5			mA
Input Power @ Saturation, (P <sub>IN</sub> ) <sup>(1)</sup>	T <sub>BASE</sub> -40 °C : 22			dBm
	T <sub>BASE</sub> +25 °C: 22			
	T <sub>BASE</sub> +85 °C: 25			
Operating Temp. Range (T <sub>BASE</sub> ) <sup>(2)</sup>	-40		+85	°C

1. See plots page 6

2. T<sub>BASE</sub> is back side of 0.02" CuMo carrier plate with AuSn solder

Electrical specifications are measured at specified test conditions. Specifications are not guaranteed over all recommended operating conditions.

### Electrical Specifications

Parameter	Conditions <sup>(1)</sup> <sup>(2)</sup>	Min	Typ.	Max	Units
Operational Frequency Range		37.5		42.5	GHz
Output Power at Saturation, P <sub>SAT</sub>	P <sub>IN</sub> = 22 dBm		36		dBm
Power Added Efficiency, PAE	P <sub>IN</sub> = 22 dBm		25		%
3 <sup>RD</sup> Intermodulation Products, IM3	P <sub>OUT</sub> /Tone = 30 dBm		-25		dBc
5 <sup>RD</sup> Intermodulation Products, IM5	ΔF = 100 MHz		-30		
Small Signal Gain, S <sub>21</sub>	P <sub>IN</sub> = -30 dBm		18		dB
Input Return Loss, IRL			10		
Output Return Loss, ORL			7		
P <sub>SAT</sub> Temperature Coefficient	T <sub>DIFF</sub> = 25 °C to 85 °C; P <sub>IN</sub> = 22 dBm		-0.05		dBm/°C
S <sub>21</sub> Temperature Coefficient	T <sub>DIFF</sub> = 25 °C to 85 °C		-0.10		dB/°C

Notes:

1. Test conditions unless otherwise noted: CW, V<sub>D</sub> = 24 V, I<sub>D</sub> = 70 mA, V<sub>G</sub> = -2.3 V +/- 0.6V typical, T<sub>BASE</sub> = 25°C, Z<sub>0</sub> = 50 Ω
2. T<sub>BASE</sub> is back side of 0.02 in CuMo carrier plate with AuSn die attached

Performance Plots – Large Signal

Test conditions, unless otherwise noted: CW,  $V_D = 24\text{ V}$ ,  $I_{DQ} = 70\text{ mA}$ ,  $P_{IN} = 22\text{ dBm}$ ,  $T_{BASE} = +25\text{ }^\circ\text{C}$  ( $T_{BASE}$  is backside of 0.02 in CuMo carrier plate)

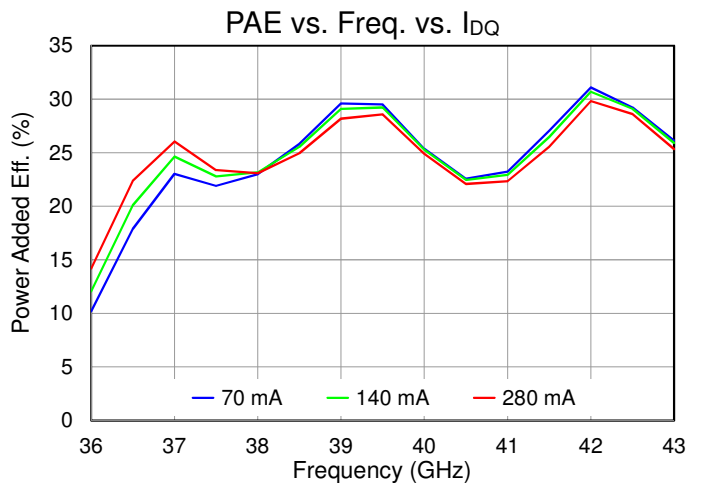
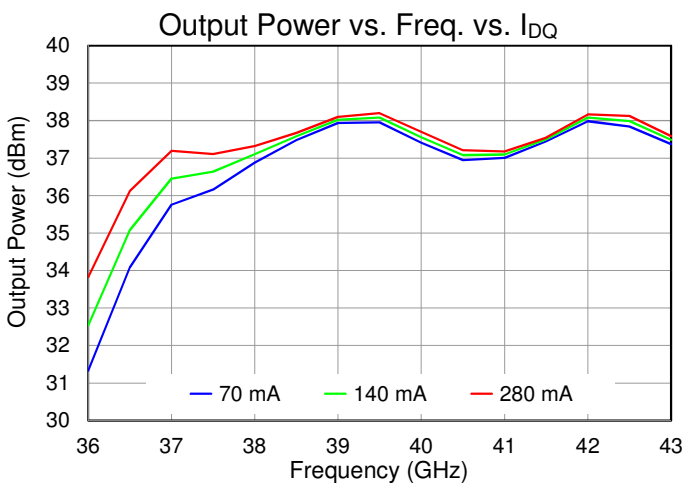
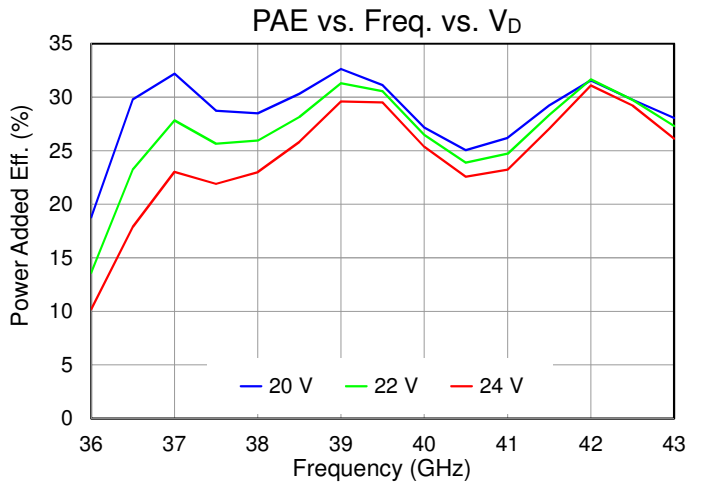
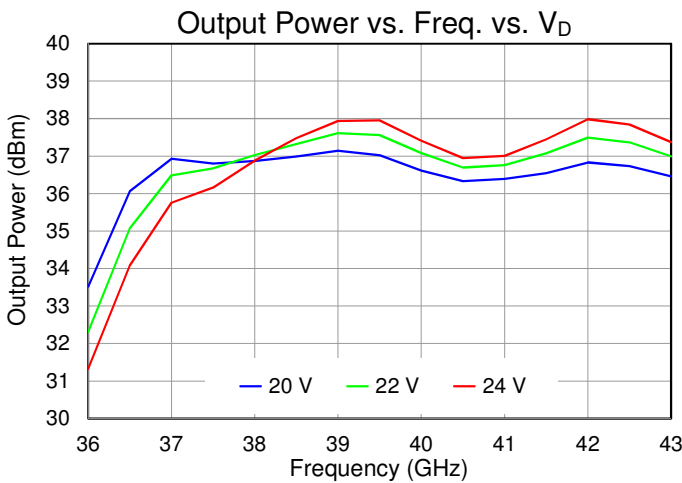
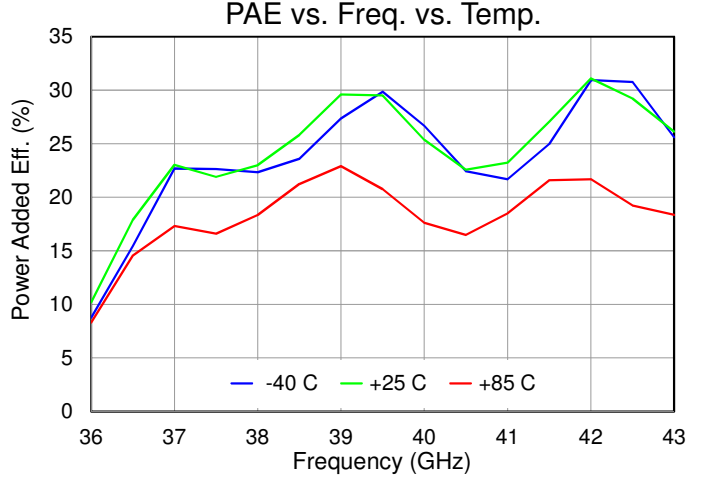
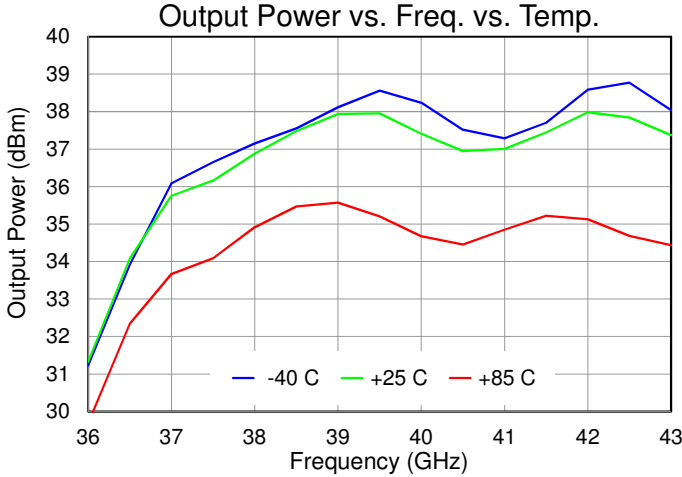

## Performance Plots – Large Signal

Test conditions, unless otherwise noted: CW,  $V_D = 24\text{ V}$ ,  $I_{DQ} = 70\text{ mA}$ ,  $P_{IN} = 22\text{ dBm}$ ,  $T_{BASE} = +25\text{ }^\circ\text{C}$  ( $T_{BASE}$  is backside of 0.02 in CuMo carrier plate)

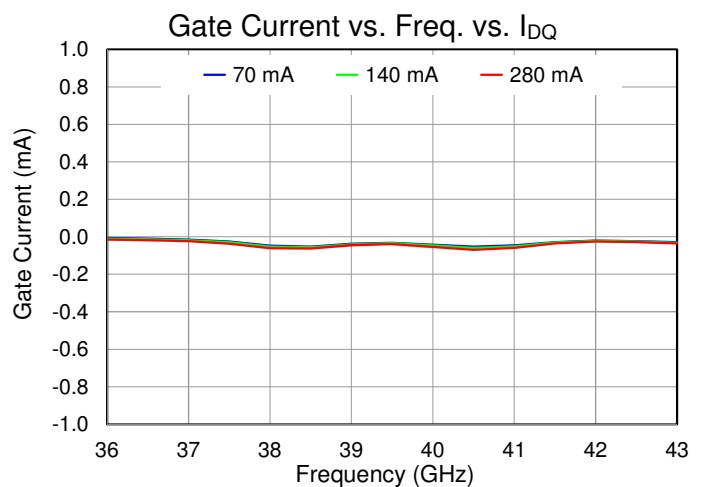
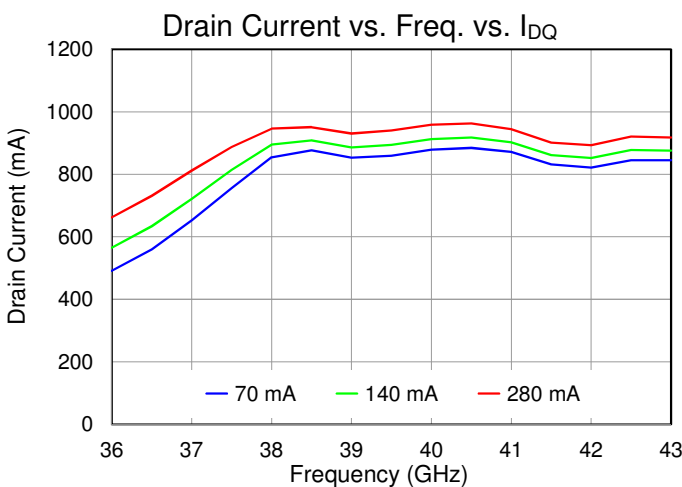
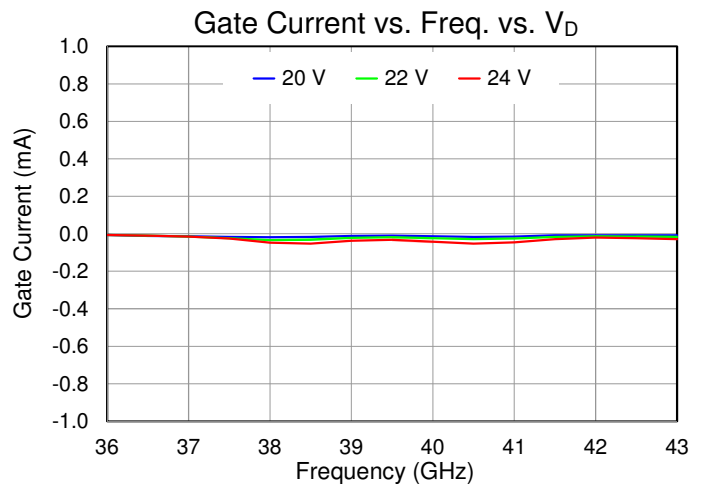
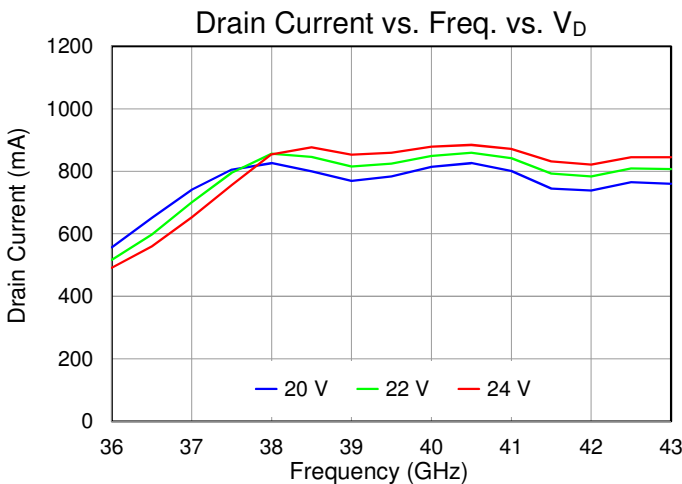
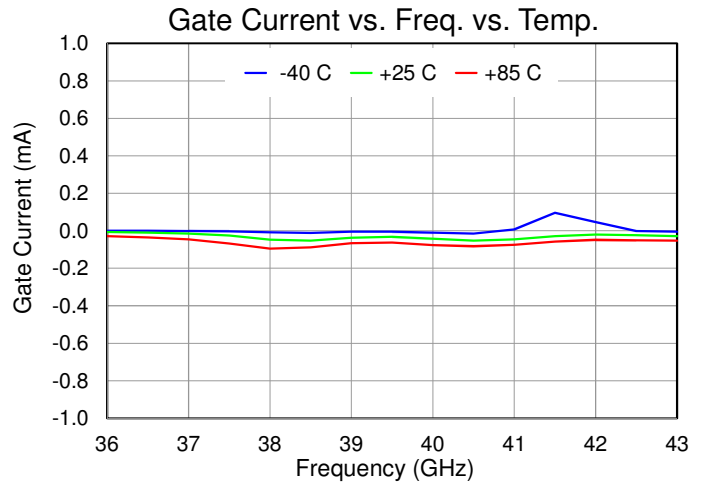
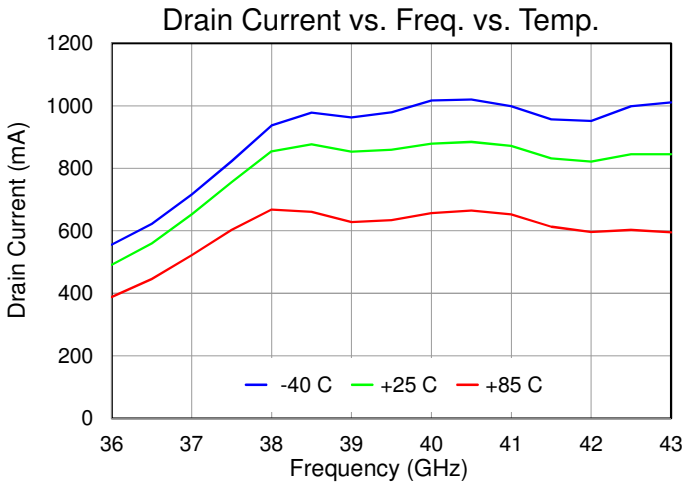

Performance Plots – Large Signal

Test conditions, unless otherwise noted: CW,  $V_D = 24\text{ V}$ ,  $I_{DQ} = 70\text{ mA}$ ,  $P_{IN} = 22\text{ dBm}$ ,  $T_{BASE} = +25\text{ }^\circ\text{C}$  ( $T_{BASE}$  is backside of 0.02 in CuMo carrier plate)

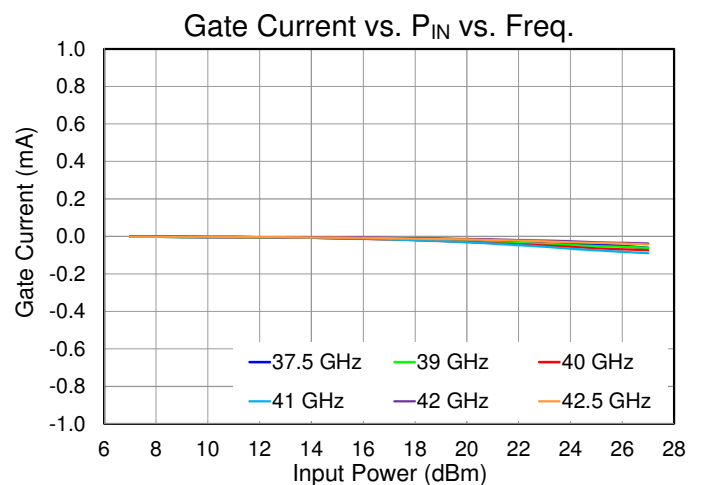
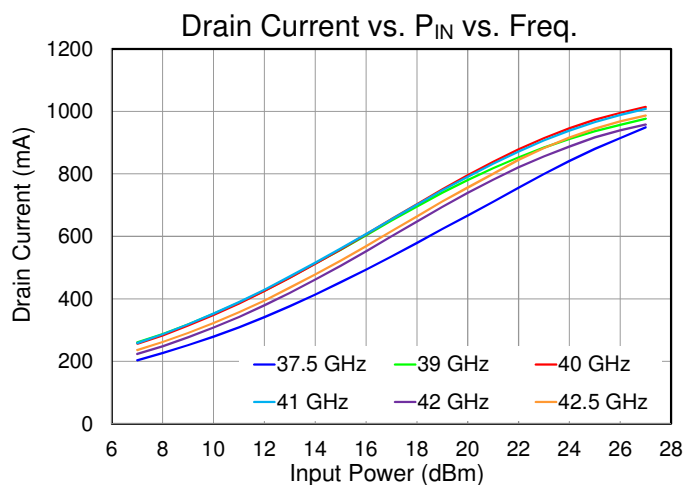
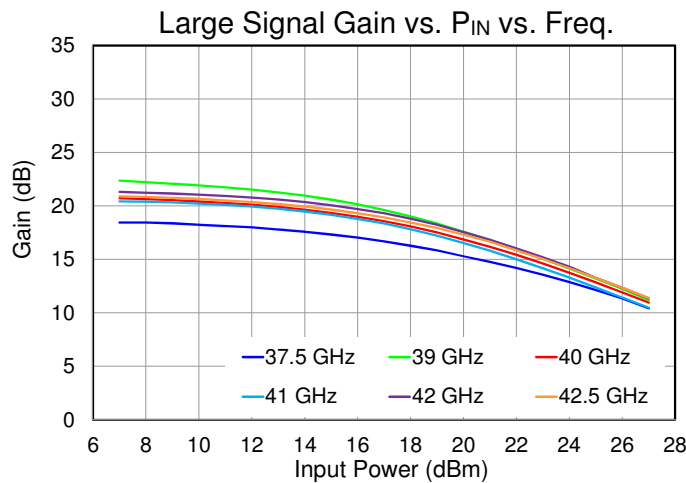
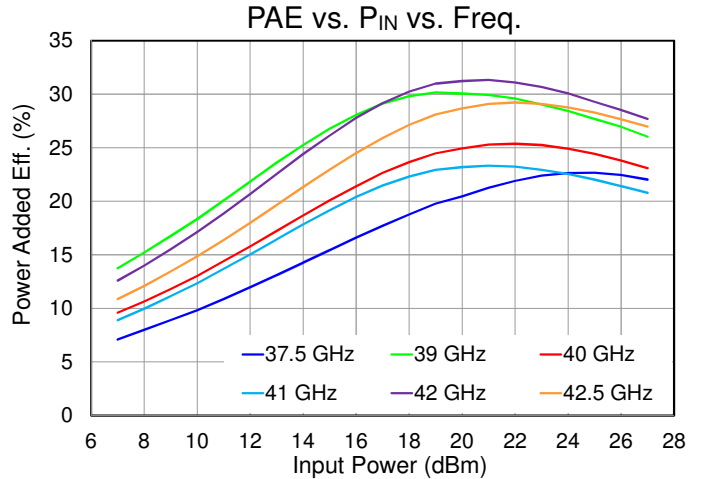
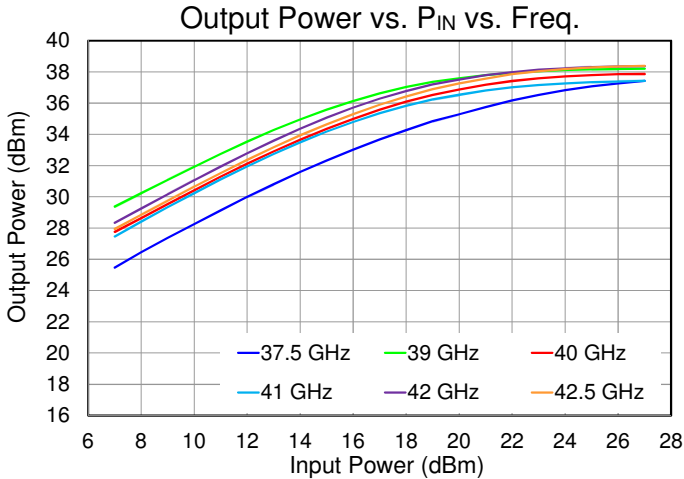

Performance Plots – Large Signal

Test conditions, unless otherwise noted: CW,  $V_D = 24\text{ V}$ ,  $I_{DQ} = 70\text{ mA}$ ,  $P_{IN} = 22\text{ dBm}$ ,  $T_{BASE} = +25\text{ }^\circ\text{C}$  ( $T_{BASE}$  is backside of 0.02 in CuMo carrier plate)

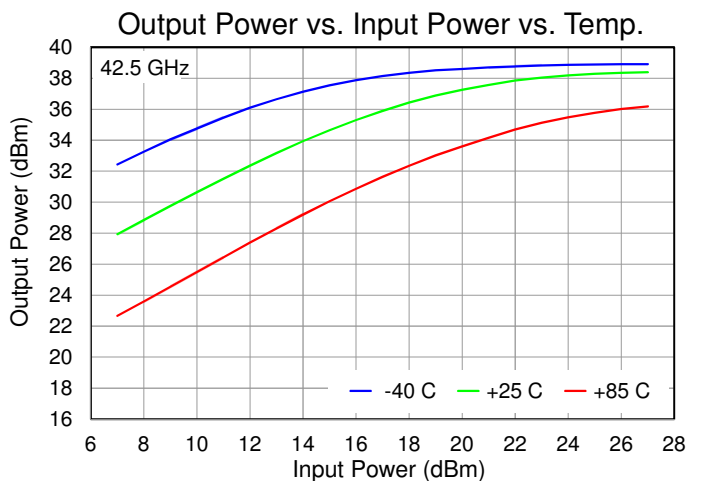
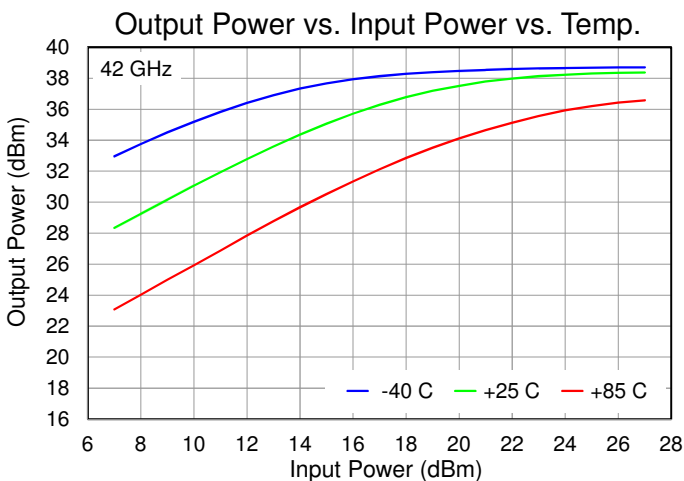
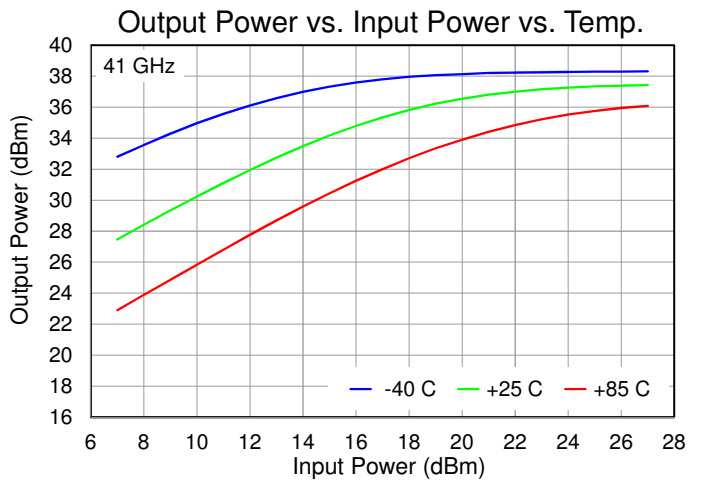
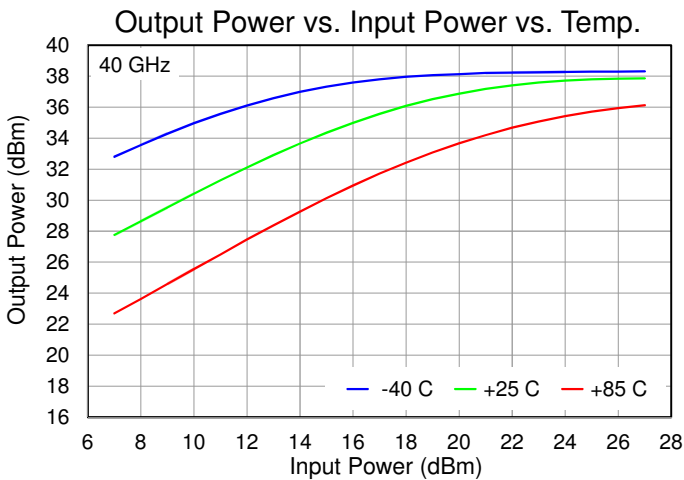
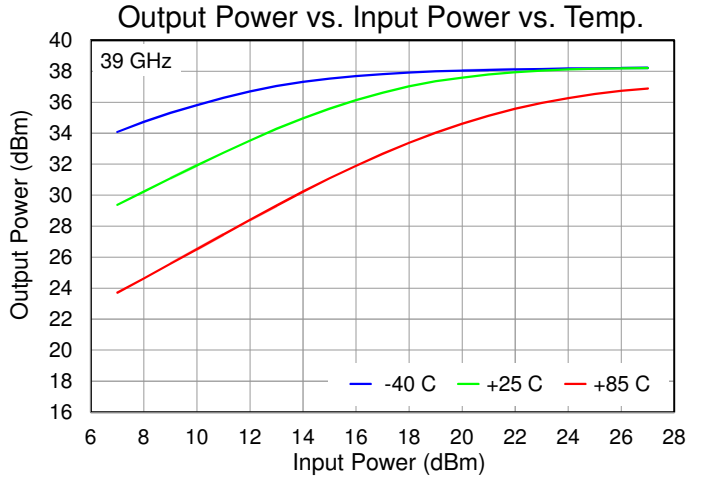
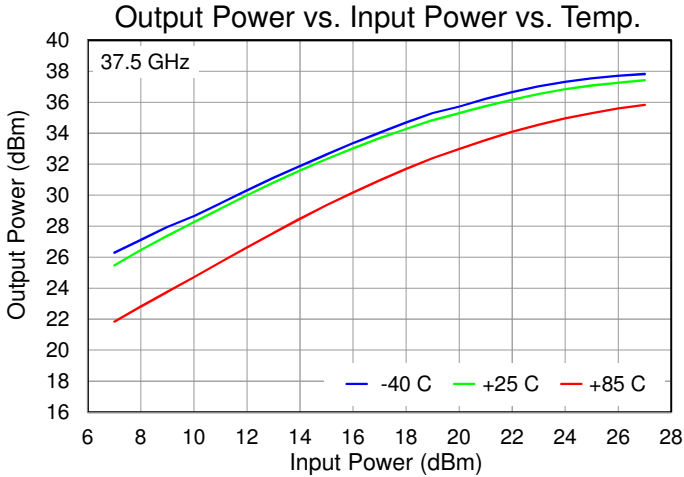

Performance Plots – Large Signal

Test conditions, unless otherwise noted: CW,  $V_D = 24\text{ V}$ ,  $I_{DQ} = 70\text{ mA}$ ,  $P_{IN} = 22\text{ dBm}$ ,  $T_{BASE} = +25\text{ }^\circ\text{C}$  ( $T_{BASE}$  is backside of 0.02 in CuMo carrier plate)

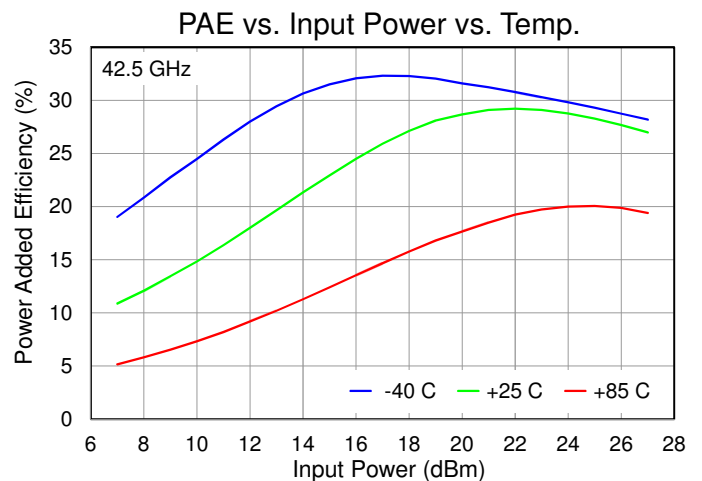
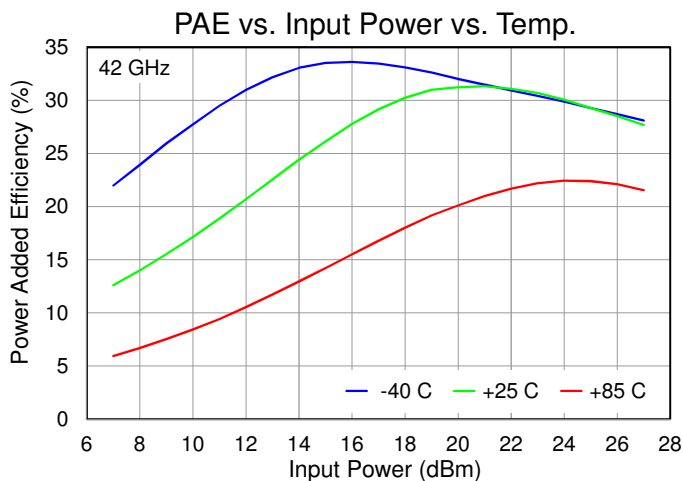
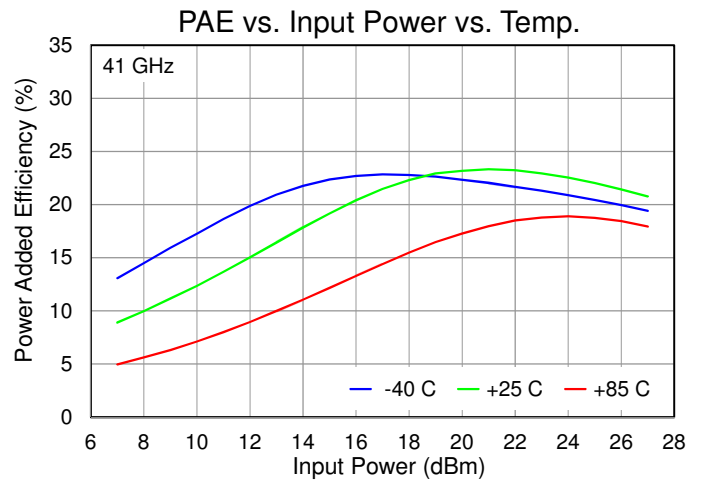
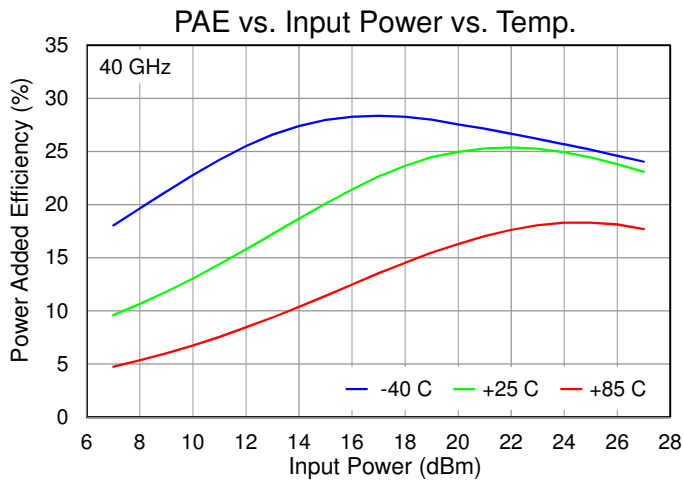
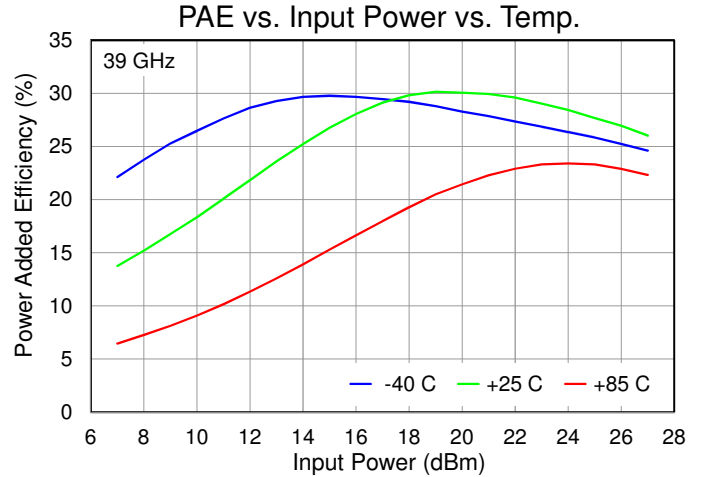
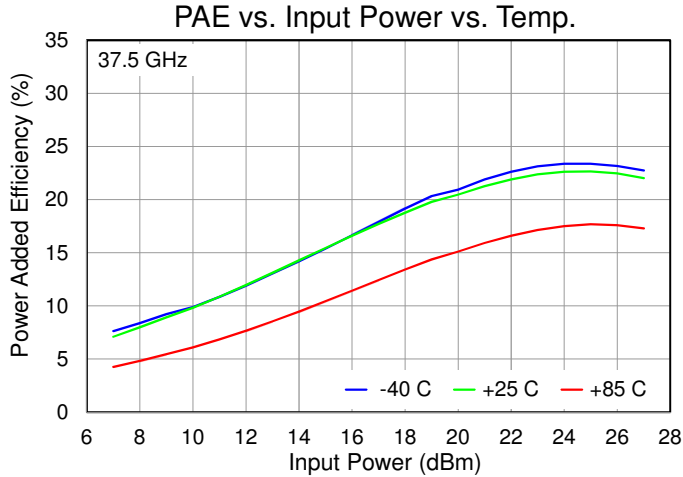

Performance Plots – Large Signal

Test conditions, unless otherwise noted: CW,  $V_D = 24\text{ V}$ ,  $I_{DQ} = 70\text{ mA}$ ,  $P_{IN} = 22\text{ dBm}$ ,  $T_{BASE} = +25\text{ }^\circ\text{C}$  ( $T_{BASE}$  is backside of 0.02 in CuMo carrier plate)

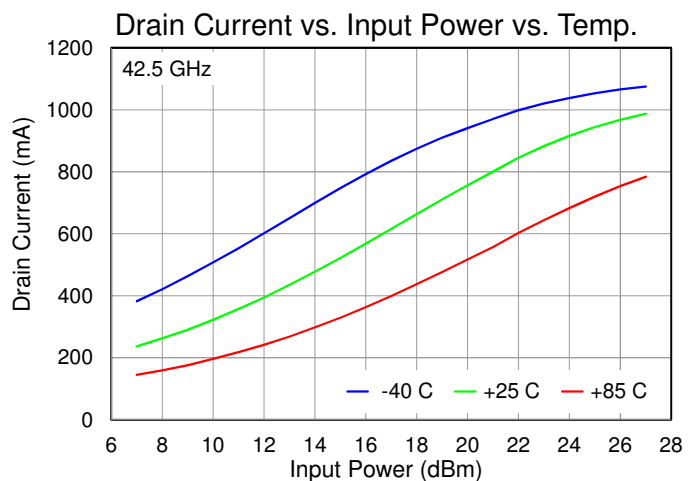
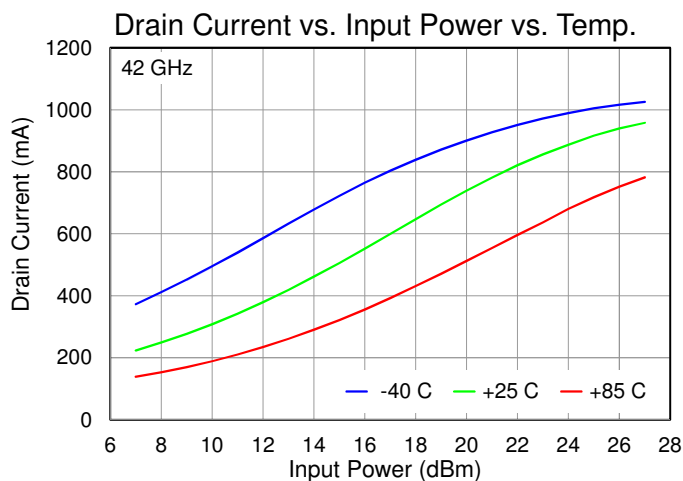
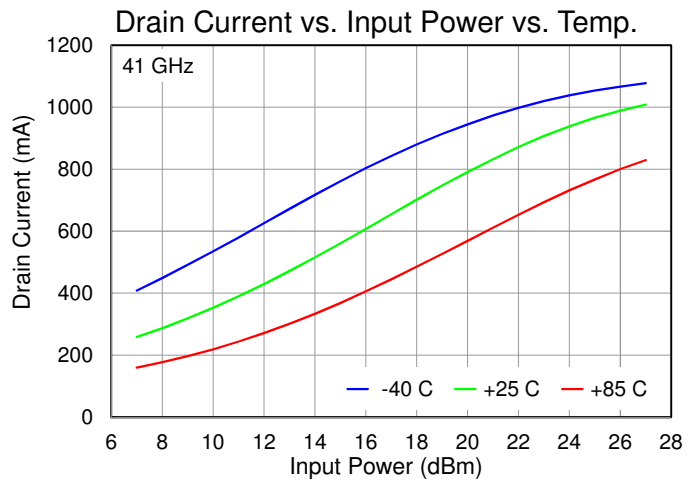
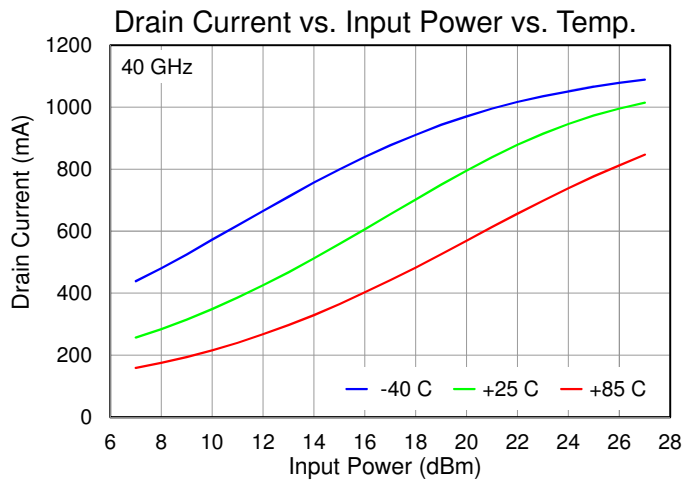
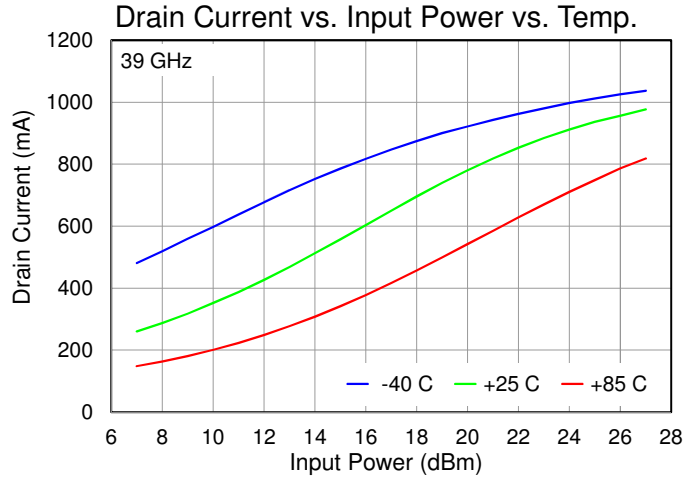
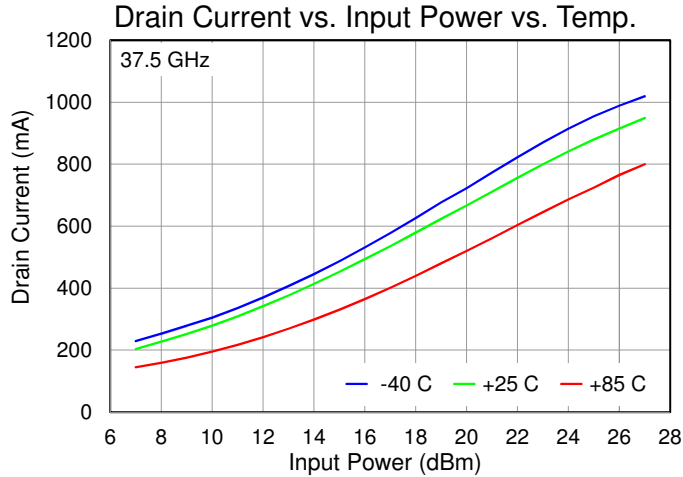

## Performance Plots – Large Signal

Test conditions, unless otherwise noted: CW,  $V_D = 24\text{ V}$ ,  $I_{DQ} = 70\text{ mA}$ ,  $P_{IN} = 22\text{ dBm}$ ,  $T_{BASE} = +25\text{ }^\circ\text{C}$  ( $T_{BASE}$  is backside of 0.02 in CuMo carrier plate)

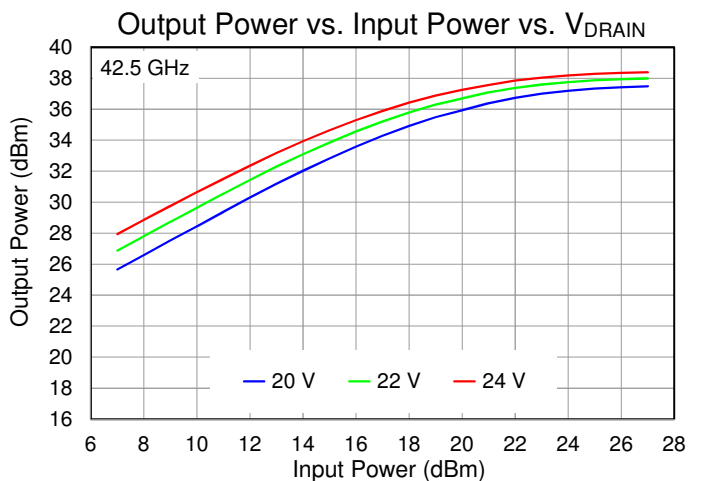
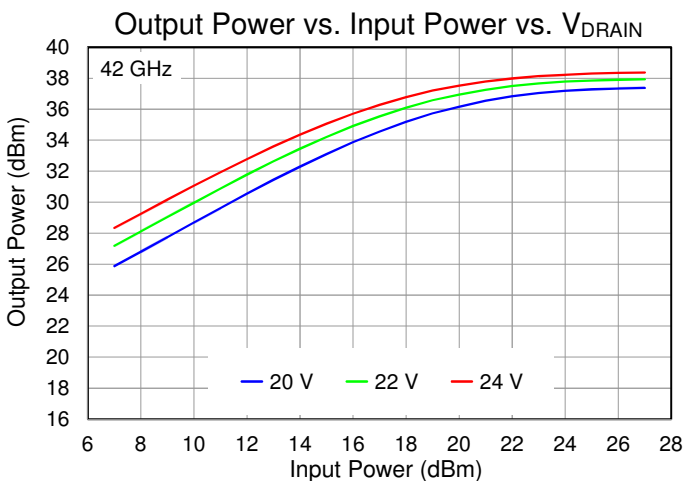
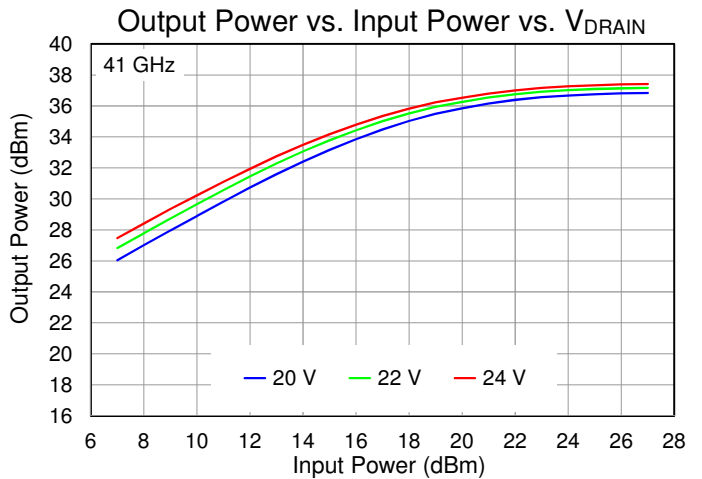
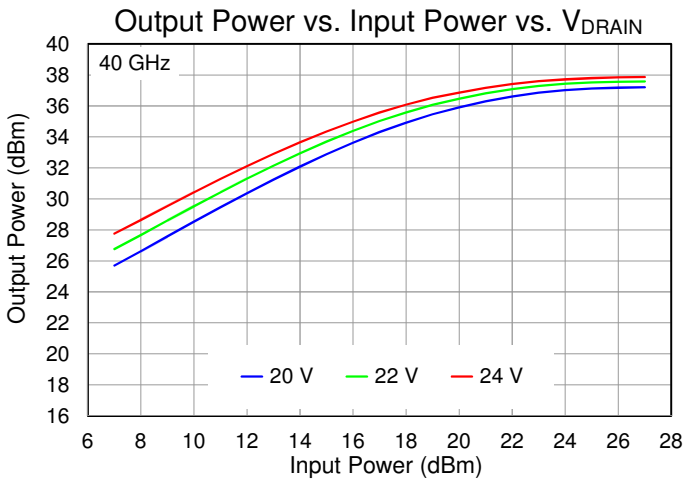
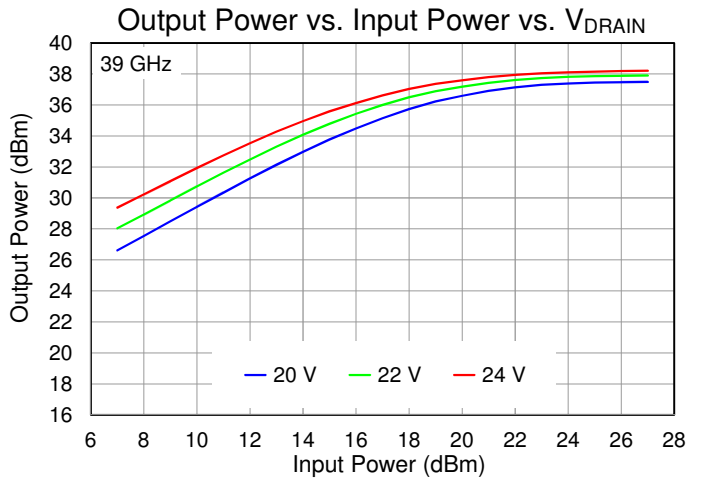
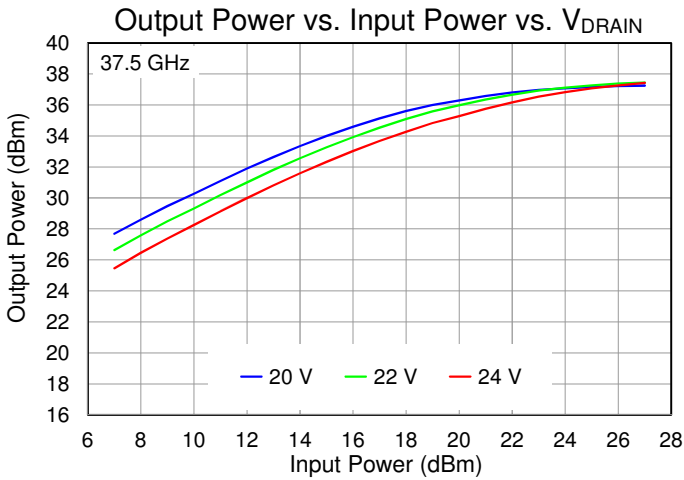

Performance Plots – Large Signal

Test conditions, unless otherwise noted: CW,  $V_D = 24\text{ V}$ ,  $I_{DQ} = 70\text{ mA}$ ,  $P_{IN} = 22\text{ dBm}$ ,  $T_{BASE} = +25\text{ }^\circ\text{C}$  ( $T_{BASE}$  is backside of 0.02 in CuMo carrier plate)

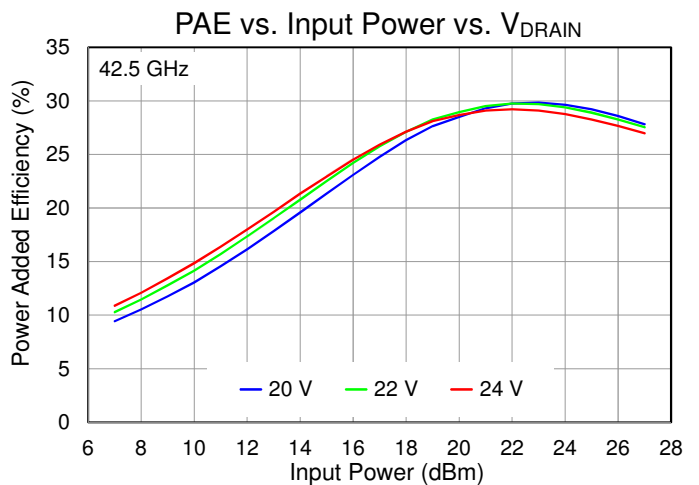
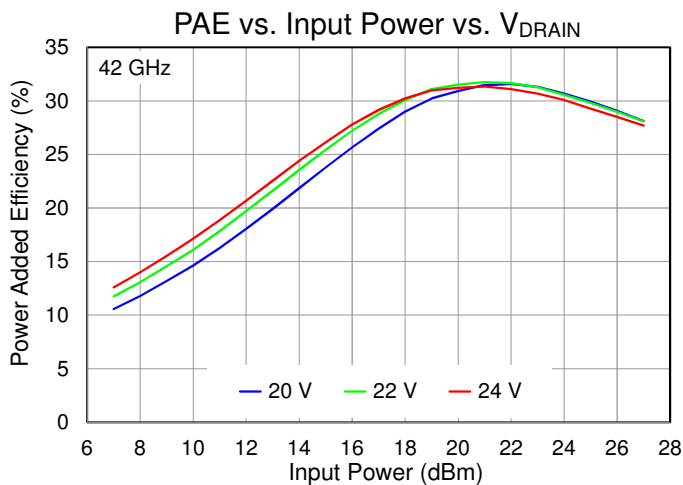
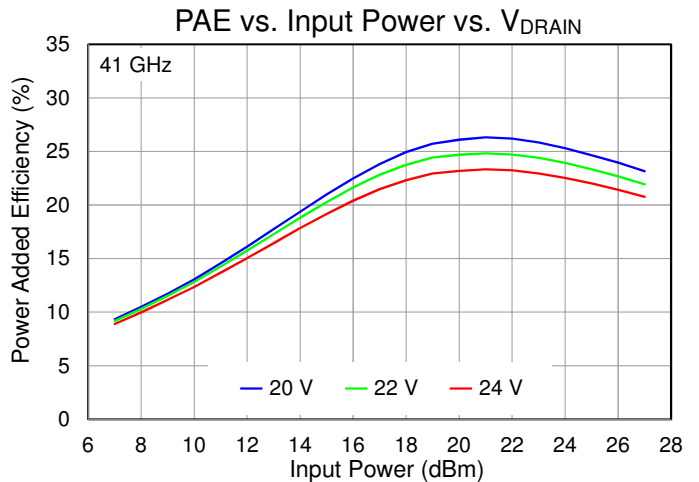
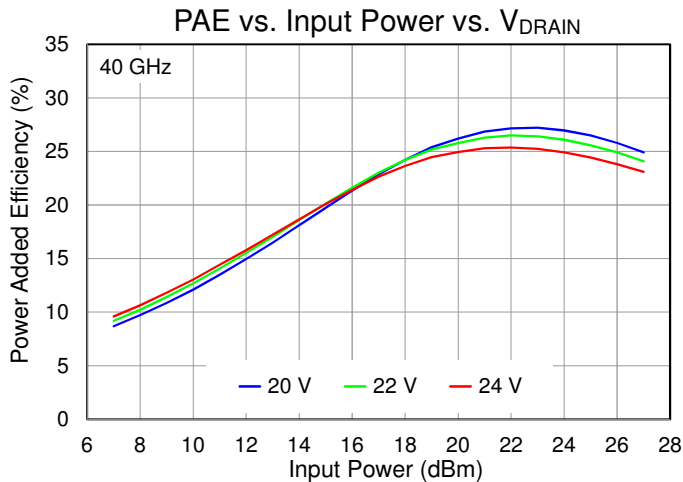
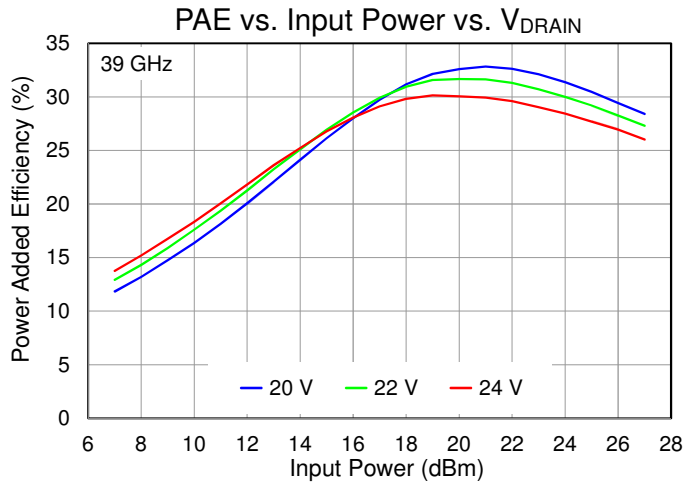
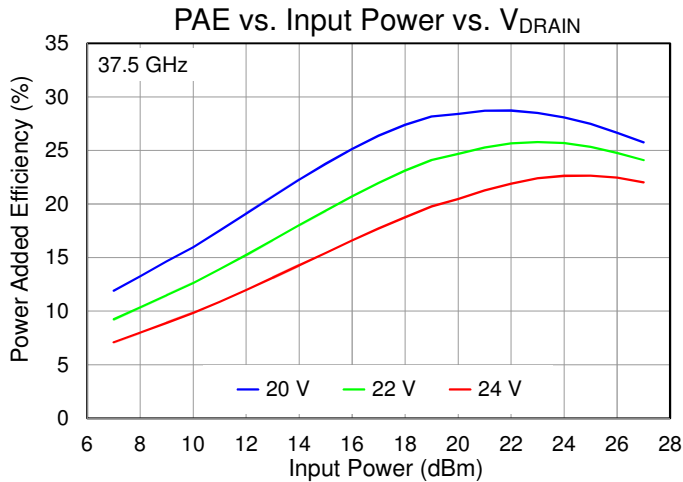

Performance Plots – Large Signal

Test conditions, unless otherwise noted: CW,  $V_D = 24\text{ V}$ ,  $I_{DQ} = 70\text{ mA}$ ,  $P_{IN} = 22\text{ dBm}$ ,  $T_{BASE} = +25\text{ }^\circ\text{C}$  ( $T_{BASE}$  is backside of 0.02 in CuMo carrier plate)

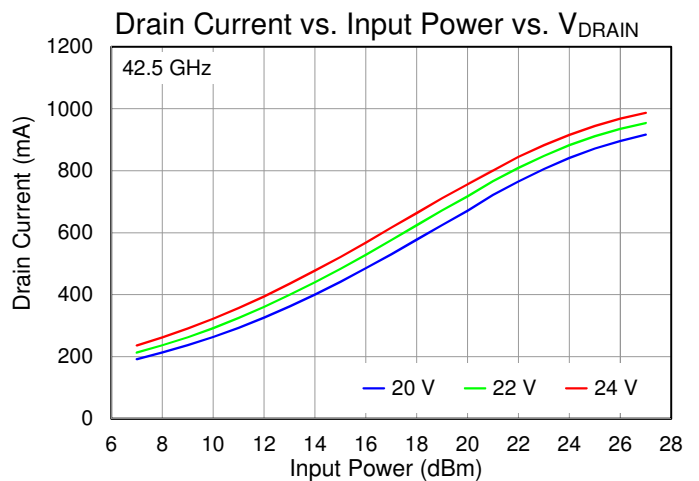
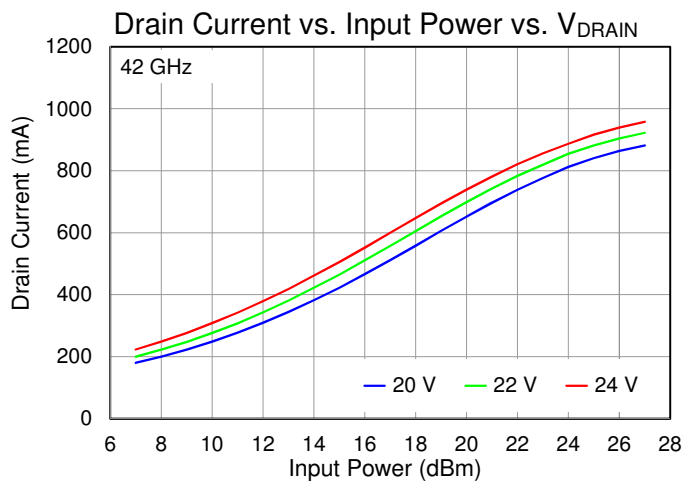
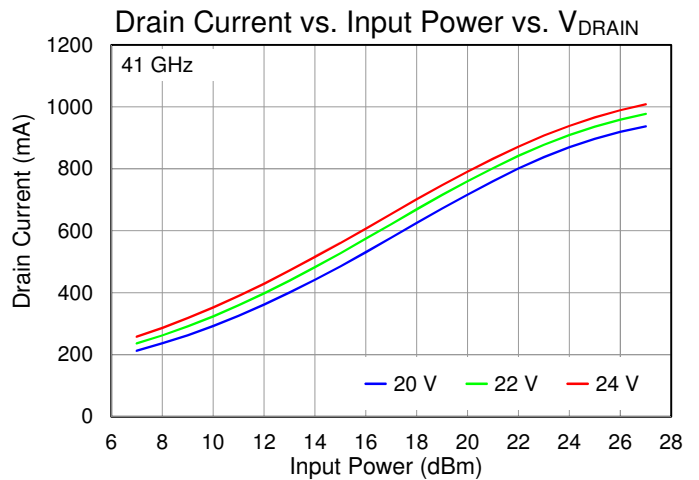
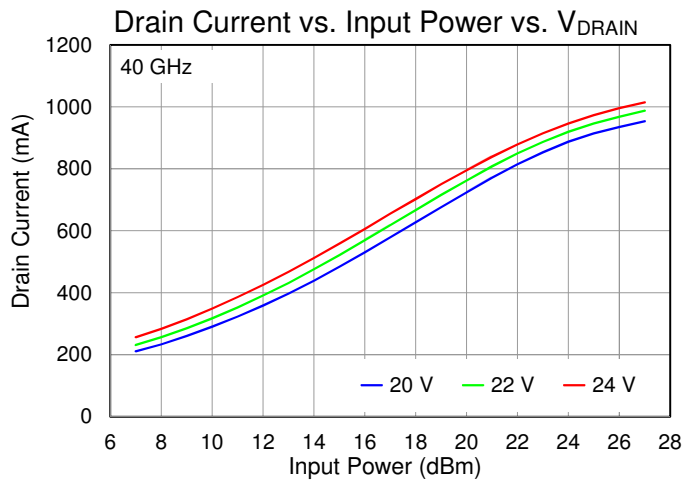
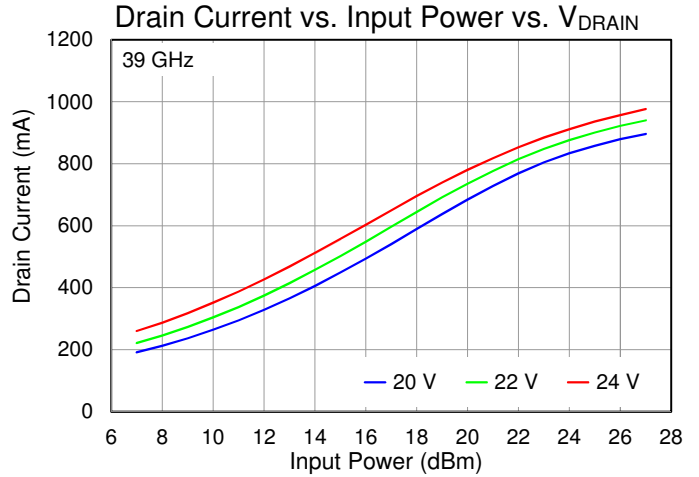
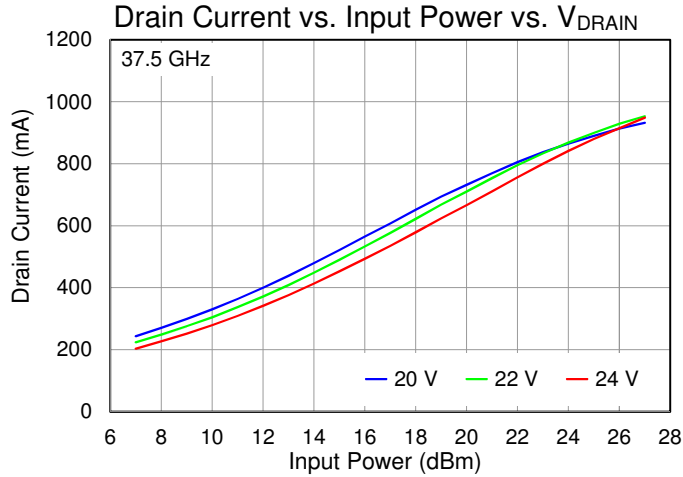

Performance Plots – Large Signal

Test conditions, unless otherwise noted: CW,  $V_D = 24\text{ V}$ ,  $I_{DQ} = 70\text{ mA}$ ,  $P_{IN} = 22\text{ dBm}$ ,  $T_{BASE} = +25\text{ }^\circ\text{C}$  ( $T_{BASE}$  is backside of 0.02 in CuMo carrier plate)

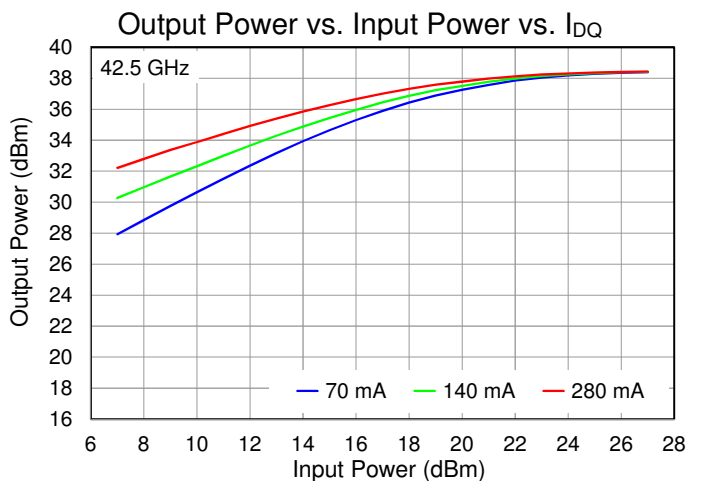
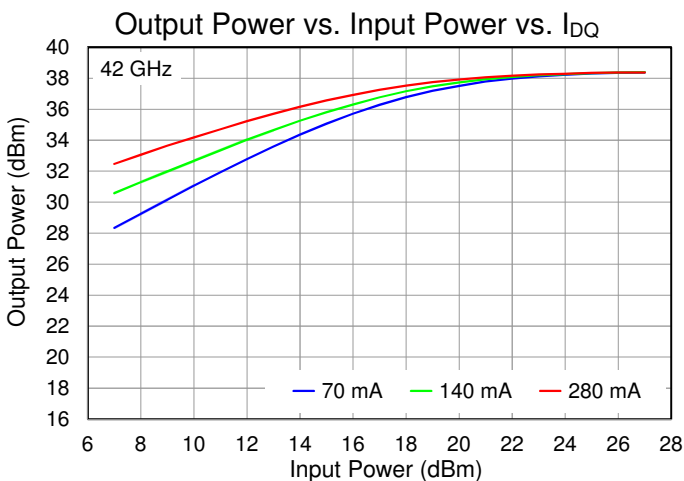
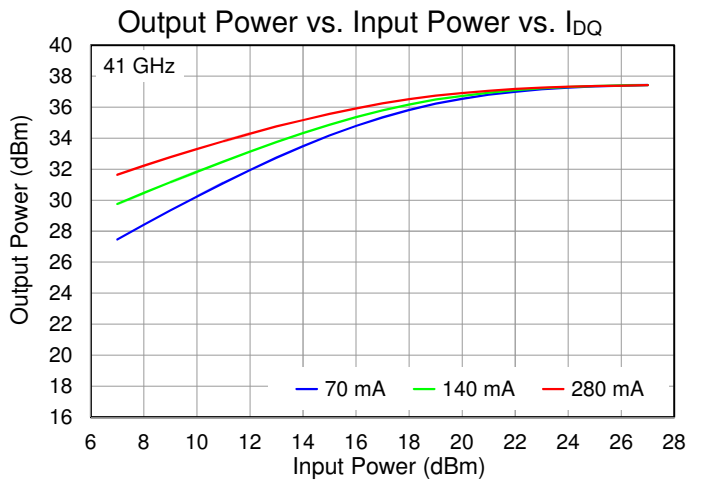
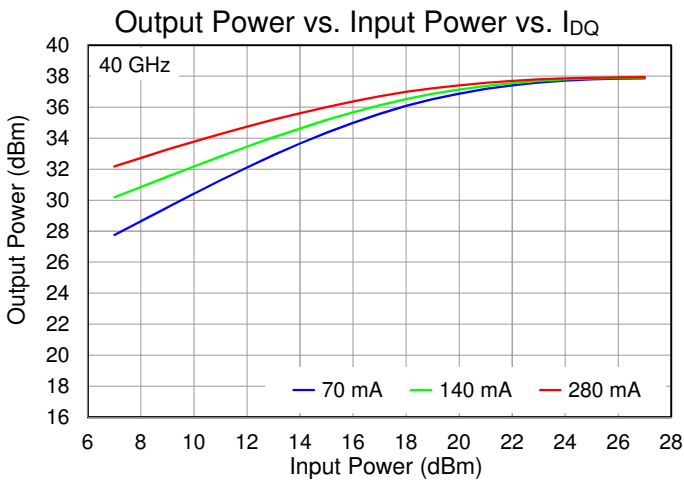
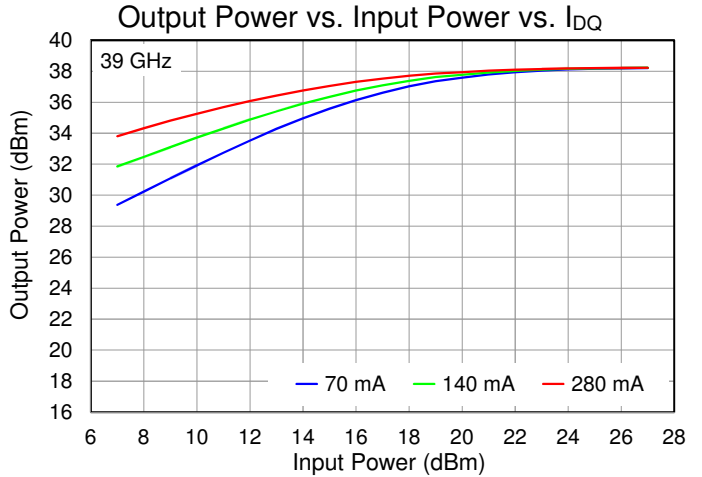
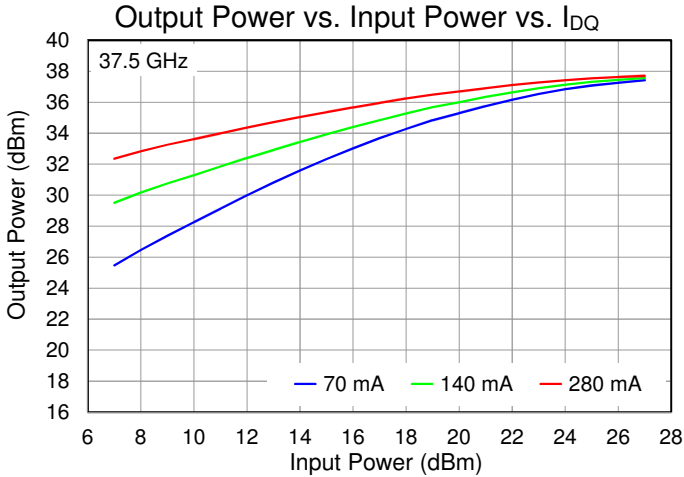

## Performance Plots – Large Signal

Test conditions, unless otherwise noted: CW,  $V_D = 24\text{ V}$ ,  $I_{DQ} = 70\text{ mA}$ ,  $P_{IN} = 22\text{ dBm}$ ,  $T_{BASE} = +25\text{ }^\circ\text{C}$  ( $T_{BASE}$  is backside of 0.02 in CuMo carrier plate)

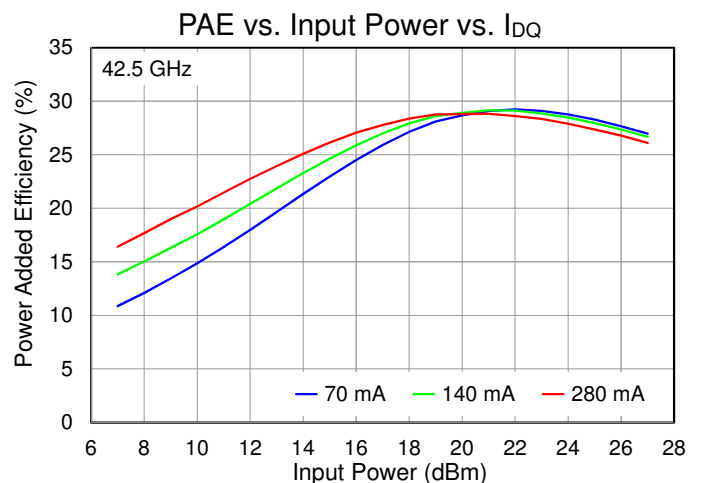
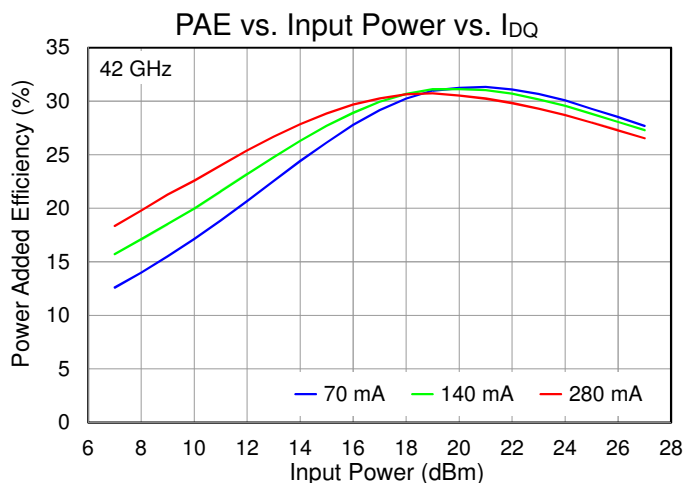
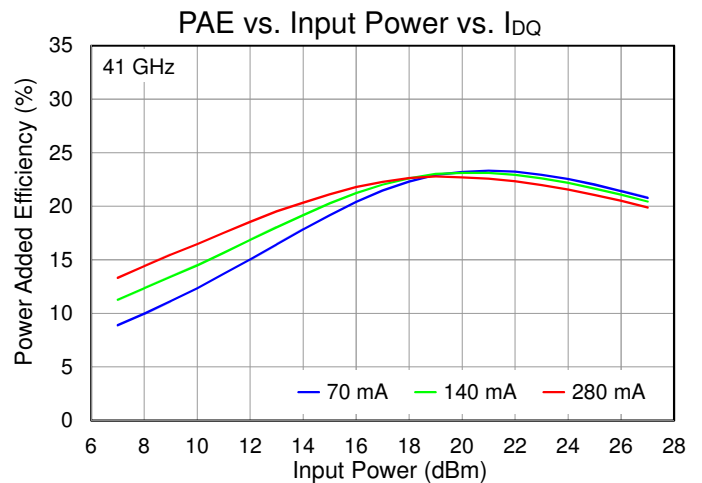
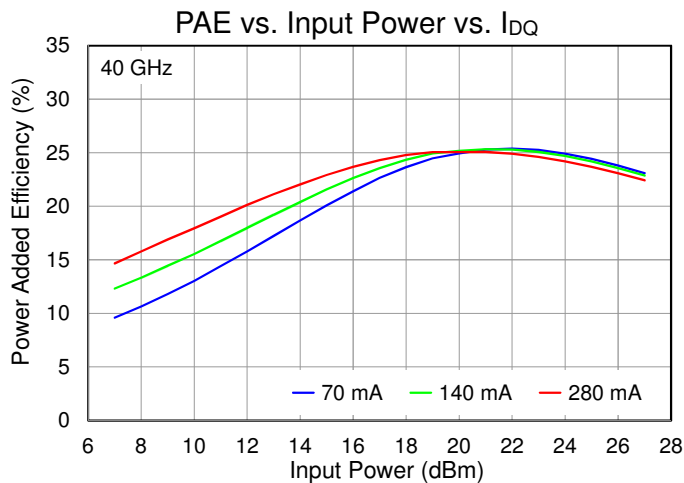
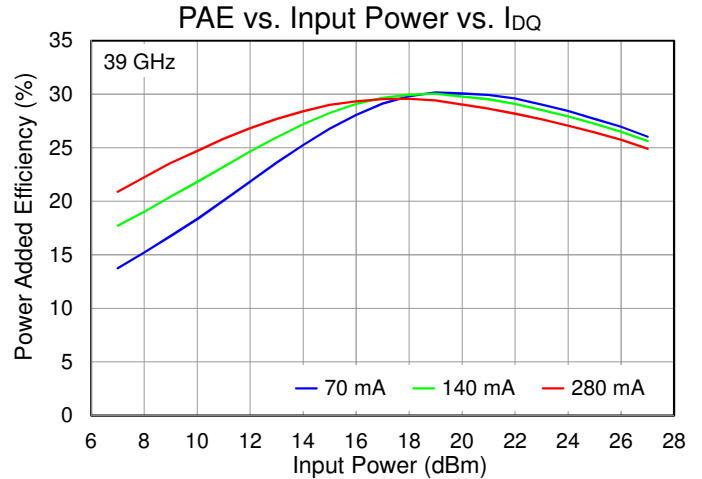
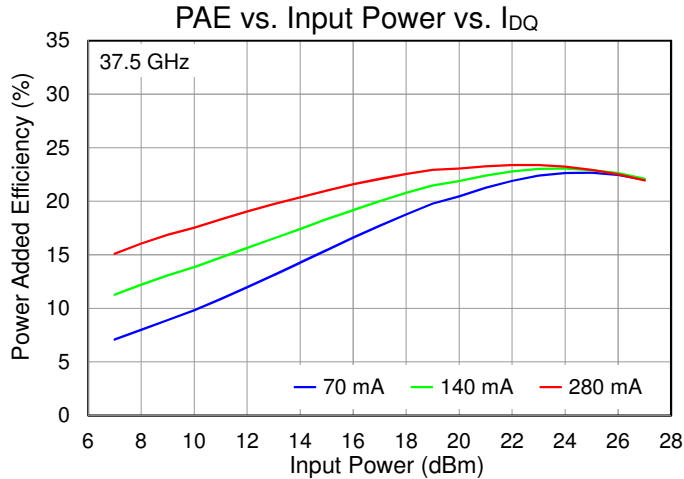

Performance Plots – Large Signal

Test conditions, unless otherwise noted: CW,  $V_D = 24\text{ V}$ ,  $I_{DQ} = 70\text{ mA}$ ,  $P_{IN} = 22\text{ dBm}$ ,  $T_{BASE} = +25\text{ }^\circ\text{C}$  ( $T_{BASE}$  is backside of 0.02 in CuMo carrier plate)

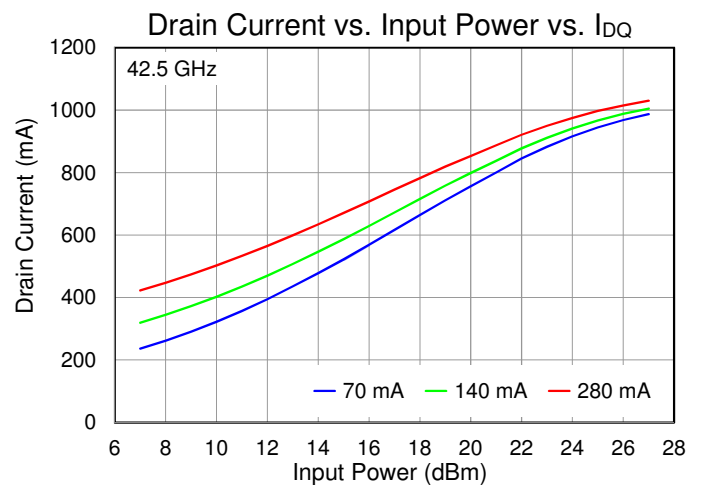
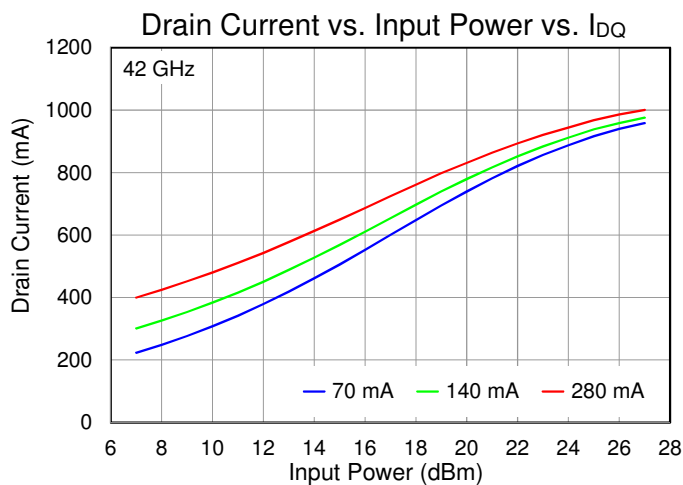
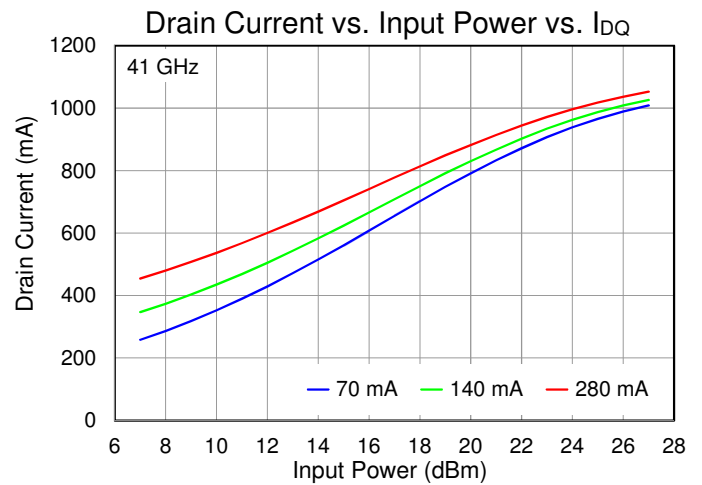
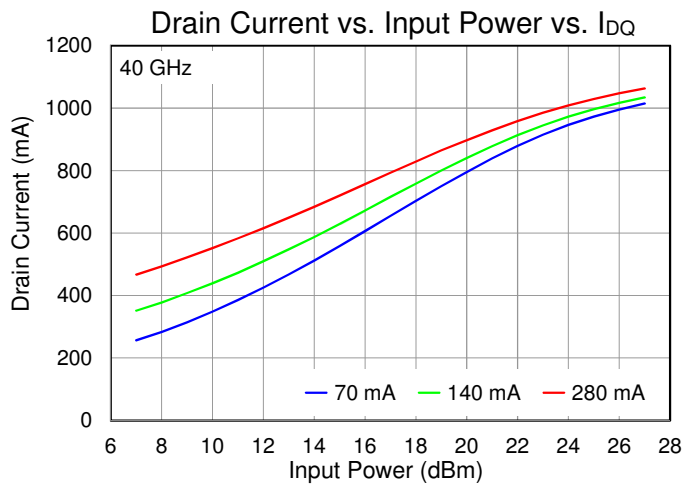
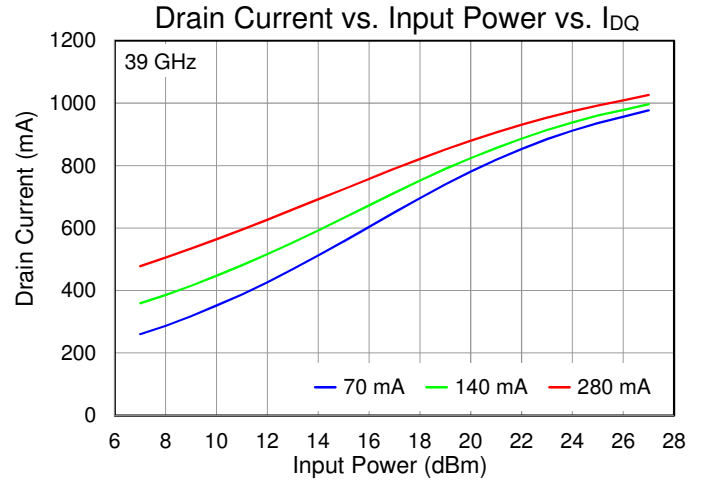
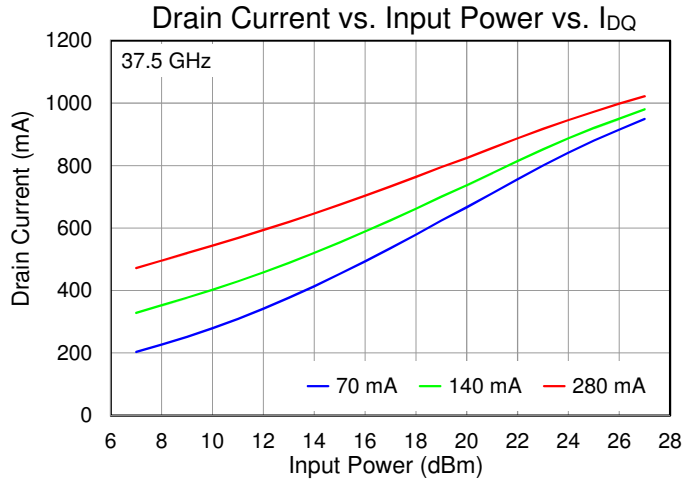

Performance Plots – Linearity

Test conditions, unless otherwise noted: CW,  $V_D = 24\text{ V}$ ,  $I_{DQ} = 70\text{ mA}$ ,  $\Delta f = 100\text{ MHz}$ ,  $T_{BASE} = +25\text{ }^\circ\text{C}$  ( $T_{BASE}$  is backside of 0.02 in CuMo carrier plate)

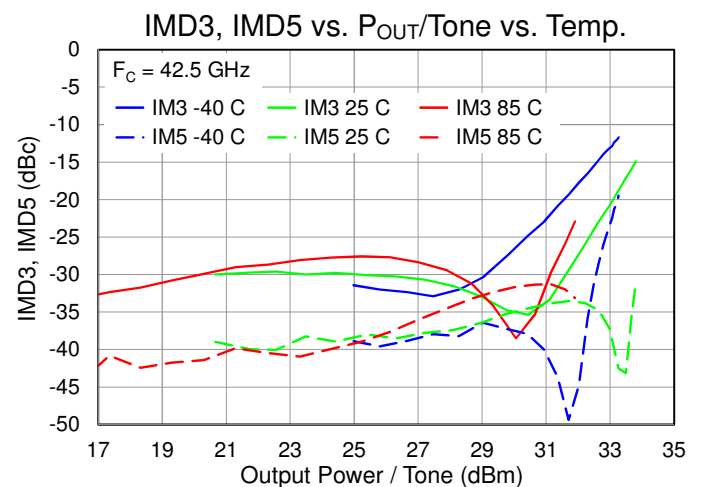
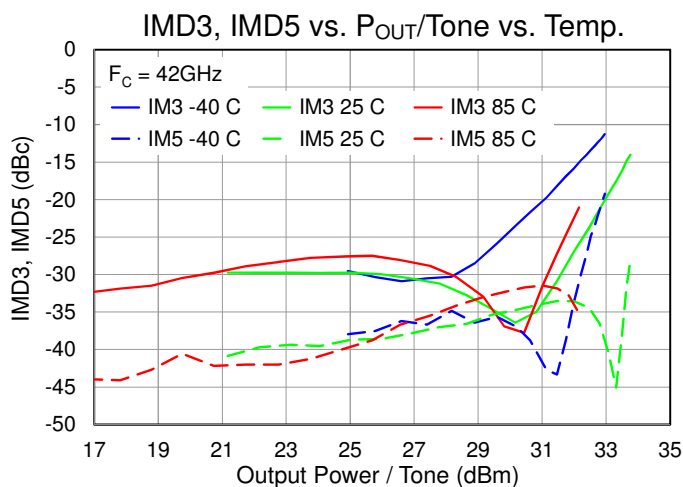
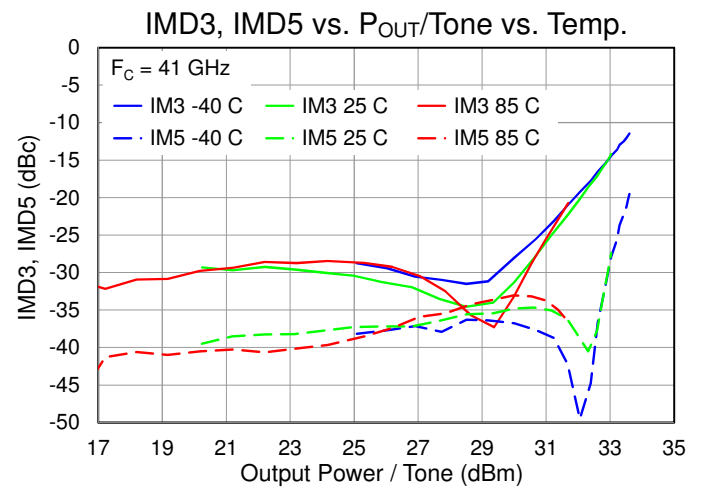
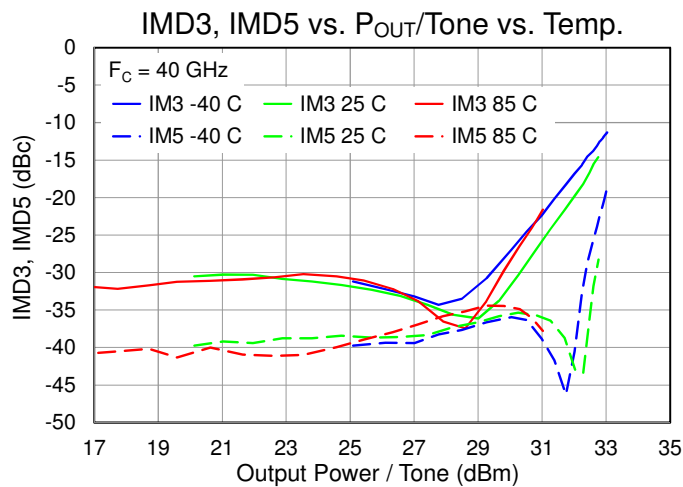
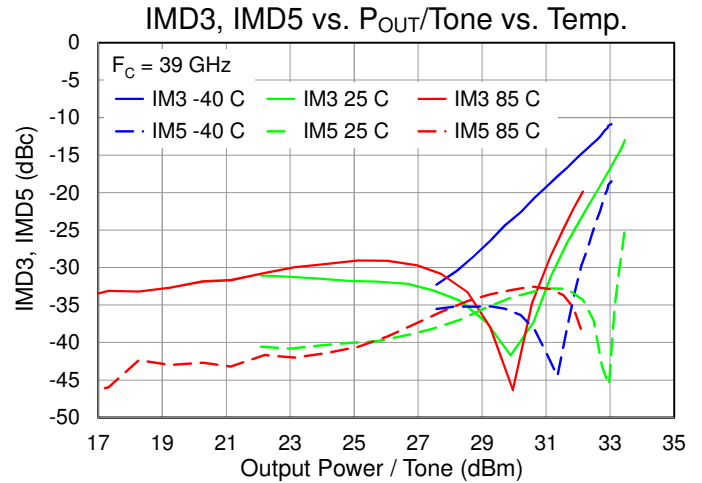
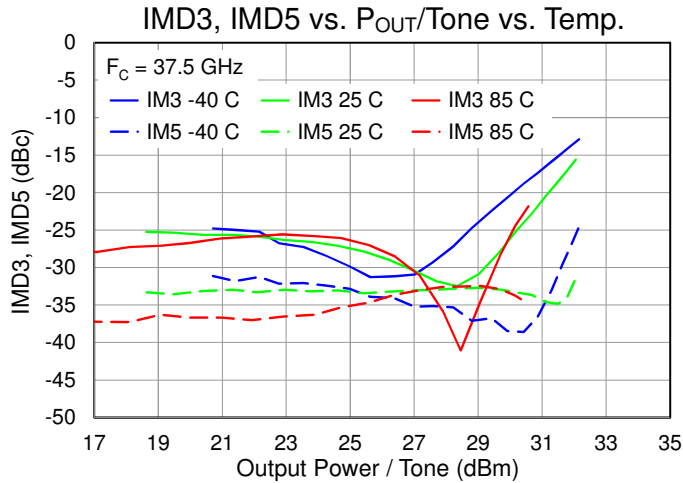

Performance Plots – Linearity

Test conditions, unless otherwise noted: CW,  $V_D = 24\text{ V}$ ,  $I_{DQ} = 70\text{ mA}$ ,  $\Delta f = 100\text{ MHz}$ ,  $T_{BASE} = +25\text{ }^\circ\text{C}$  ( $T_{BASE}$  is backside of 0.02 in CuMo carrier plate)

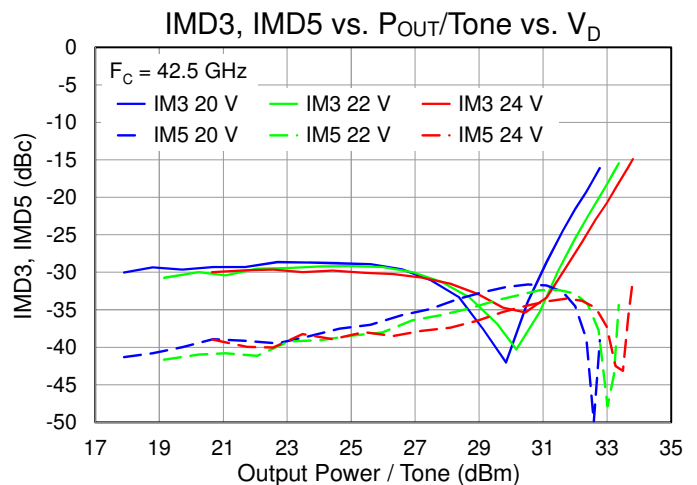
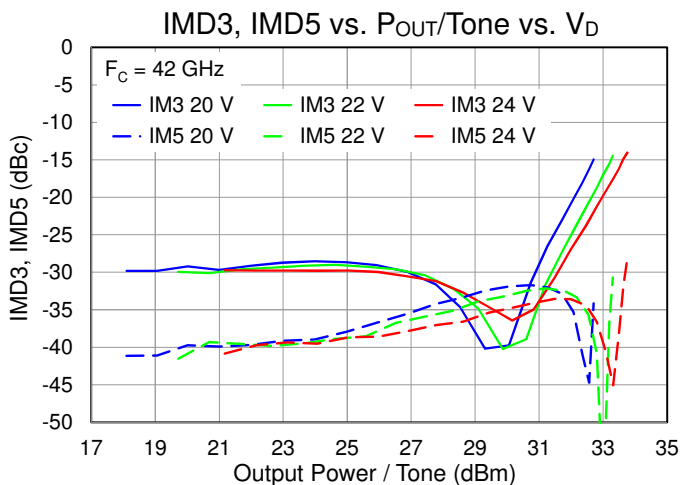
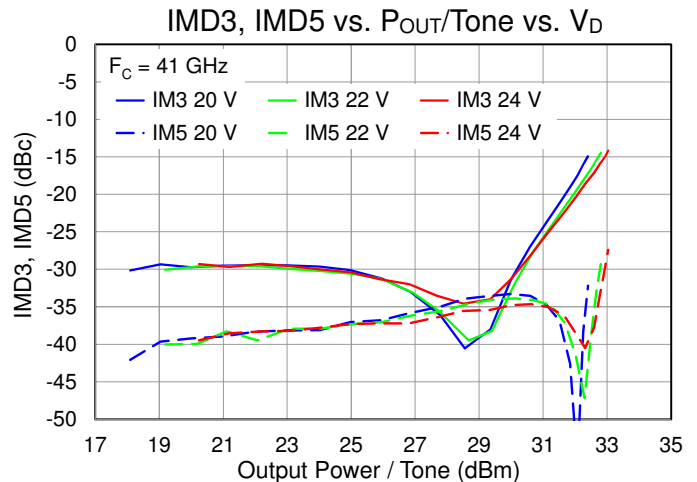
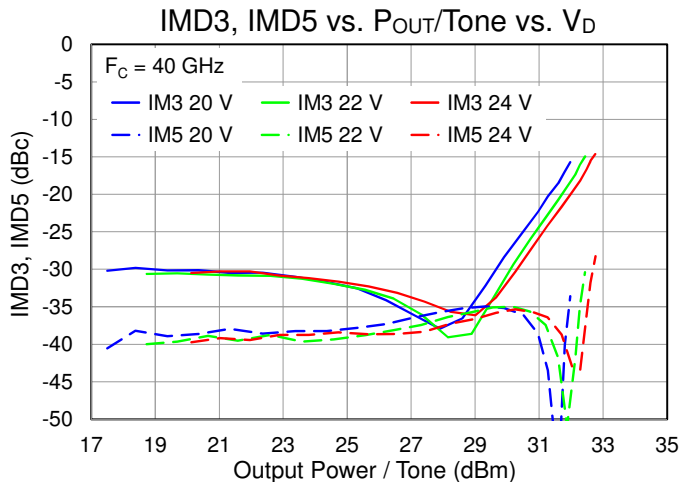
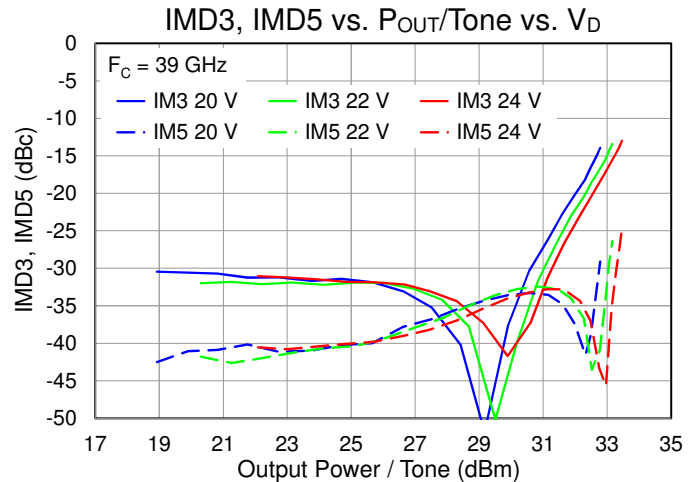
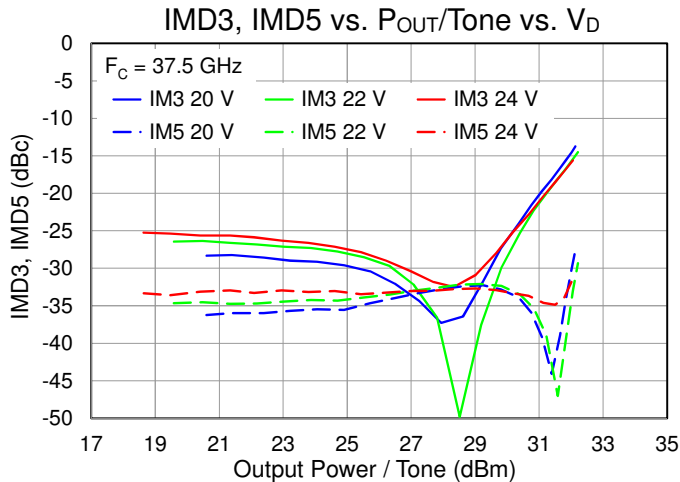

Performance Plots – Linearity

Test conditions, unless otherwise noted: CW,  $V_D = 24$  V,  $I_{DQ} = 70$  mA,  $\Delta f = 100$  MHz,  $T_{BASE} = +25$  °C ( $T_{BASE}$  is backside of 0.02 in CuMo carrier plate)

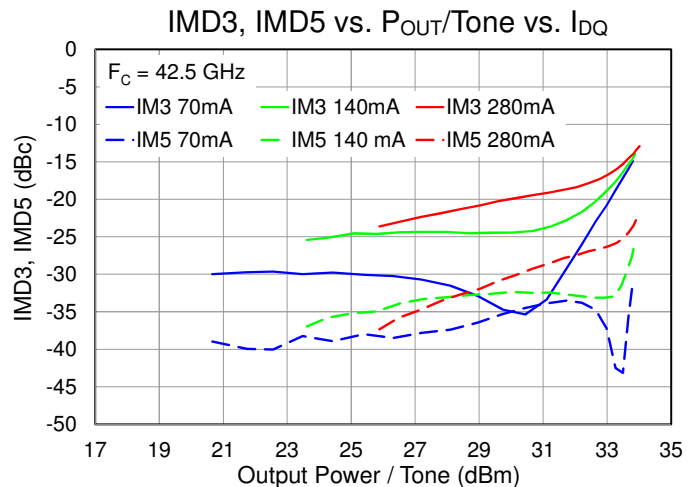
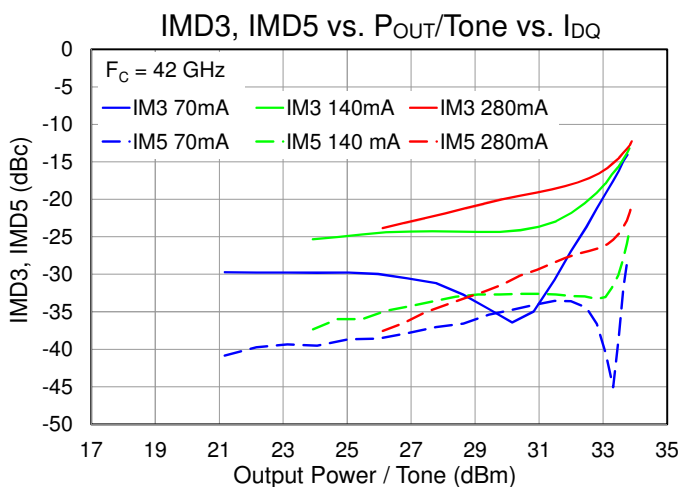
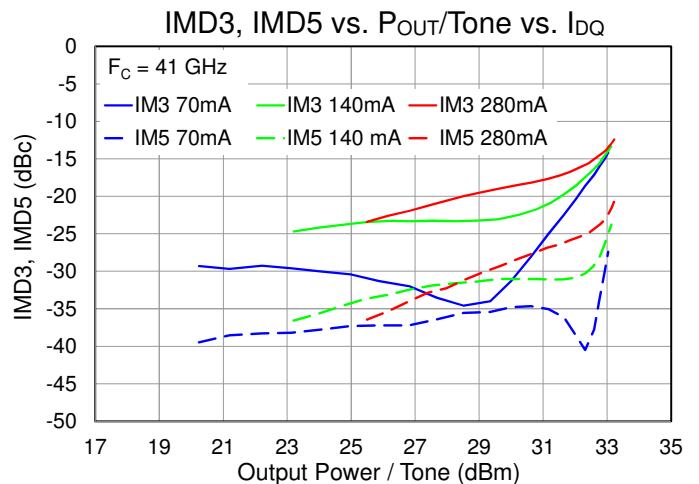
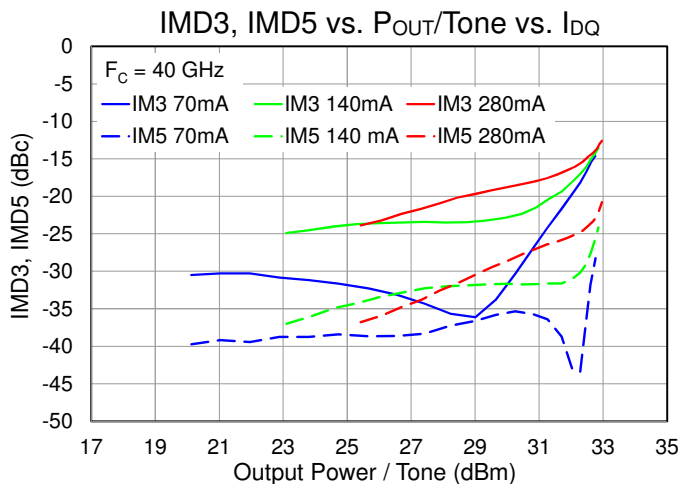
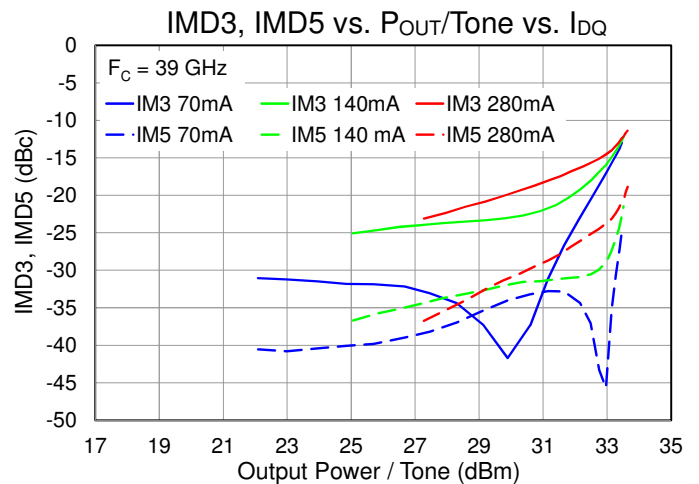
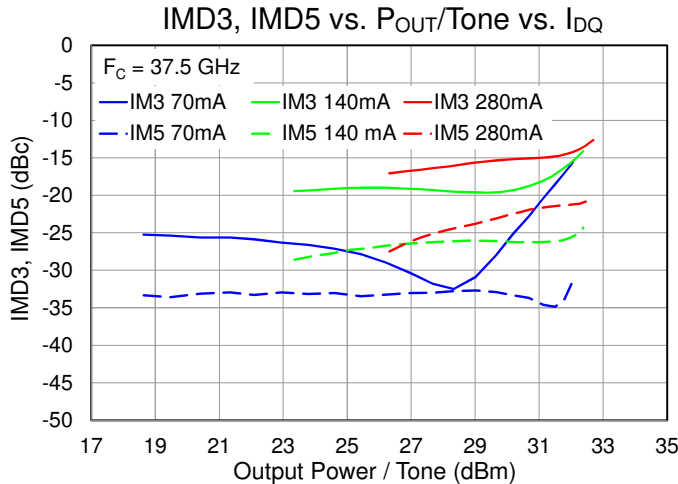

Performance Plots – Linearity

Test conditions, unless otherwise noted: CW,  $V_D = 24\text{ V}$ ,  $I_{DQ} = 70\text{ mA}$ ,  $F_C = 40\text{ GHz}$ ,  $T_{BASE} = +25\text{ }^\circ\text{C}$  ( $T_{BASE}$  is backside of 0.02 in CuMo carrier plate)

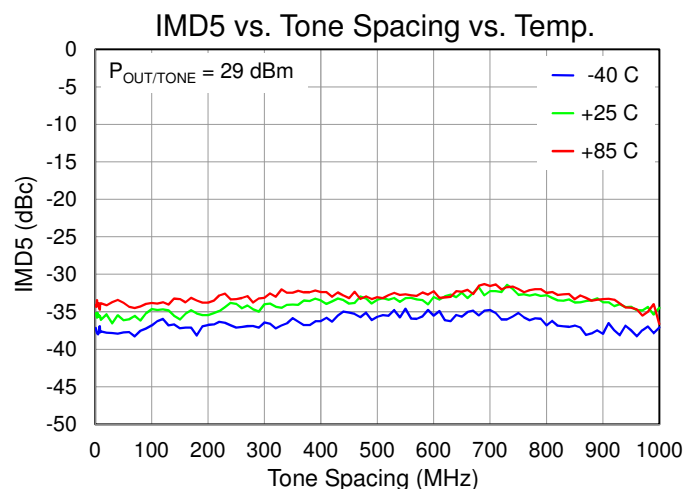
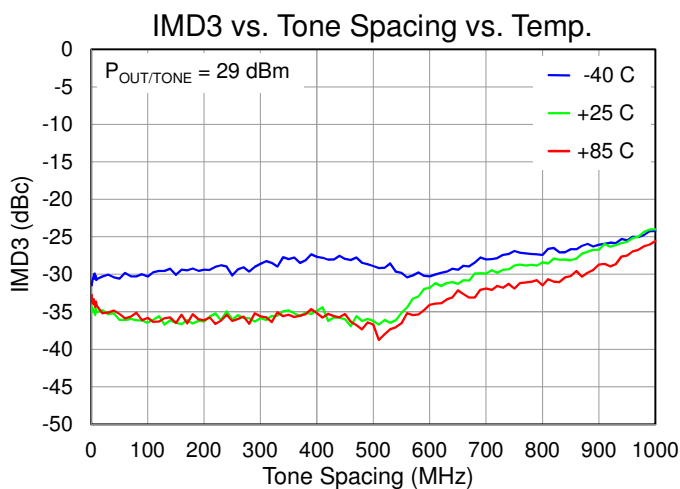
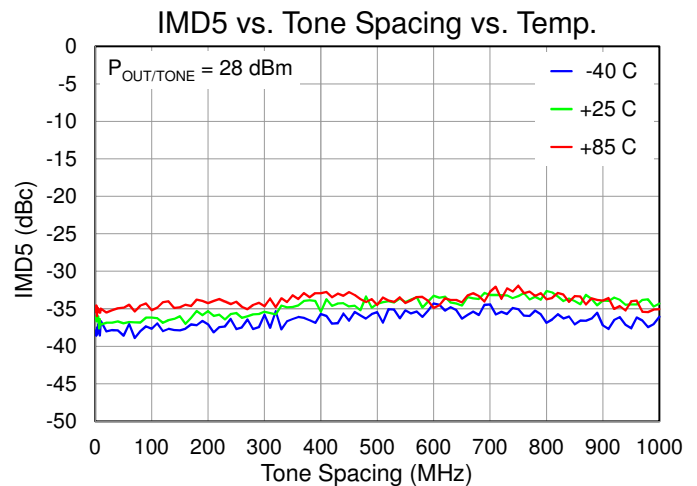
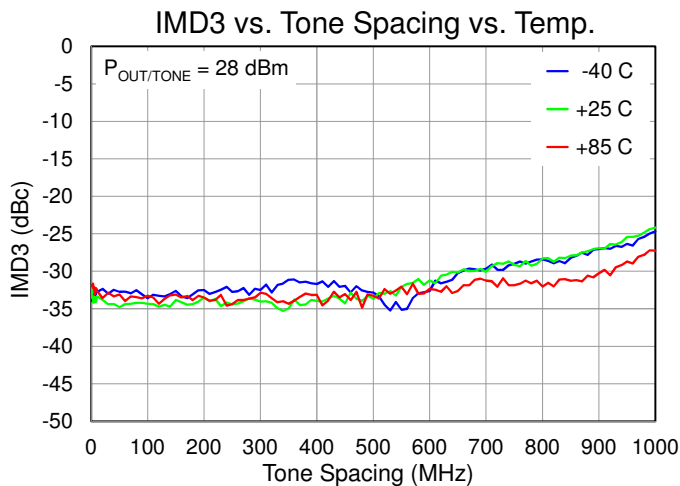
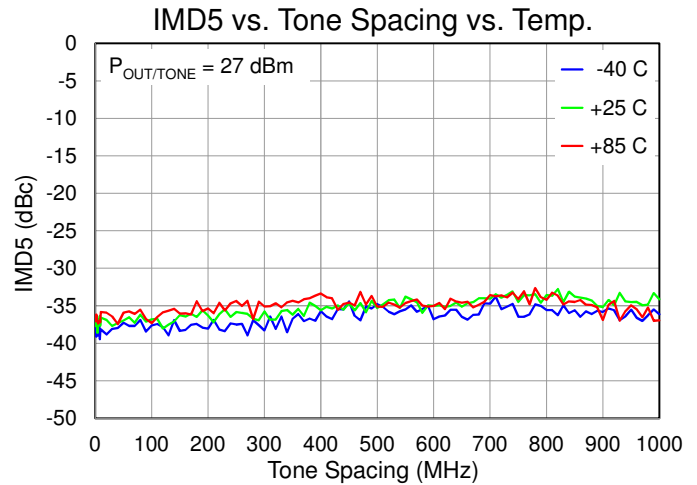
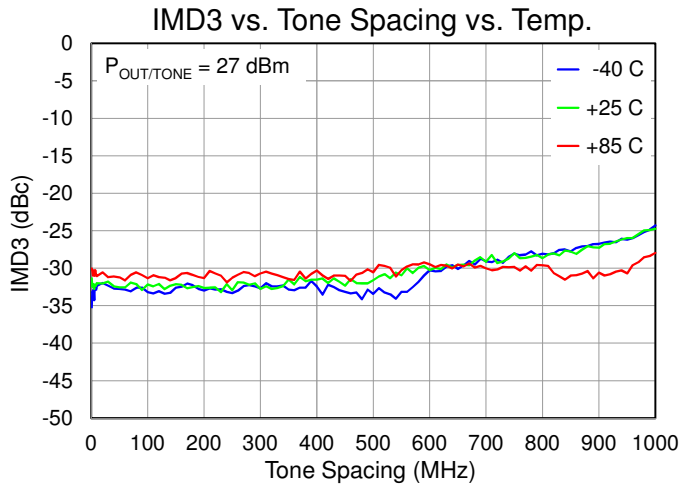

Performance Plots – Linearity

Test conditions, unless otherwise noted: CW,  $V_D = 24\text{ V}$ ,  $I_{DQ} = 70\text{ mA}$ ,  $F_C = 40\text{ GHz}$ ,  $T_{BASE} = +25\text{ }^\circ\text{C}$  ( $T_{BASE}$  is backside of 0.02 in CuMo carrier plate)

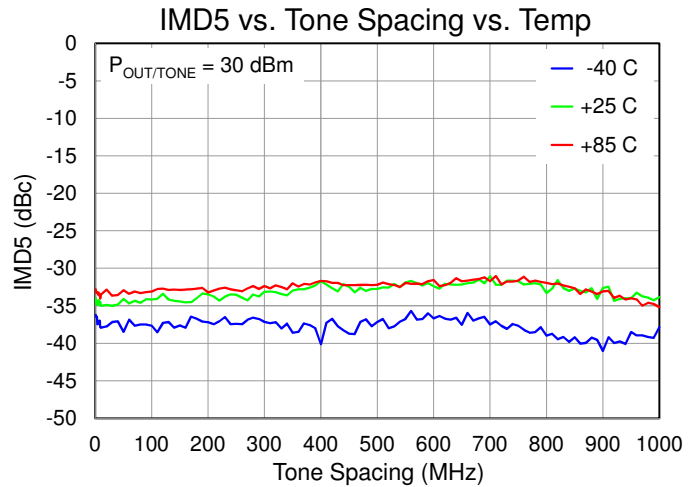
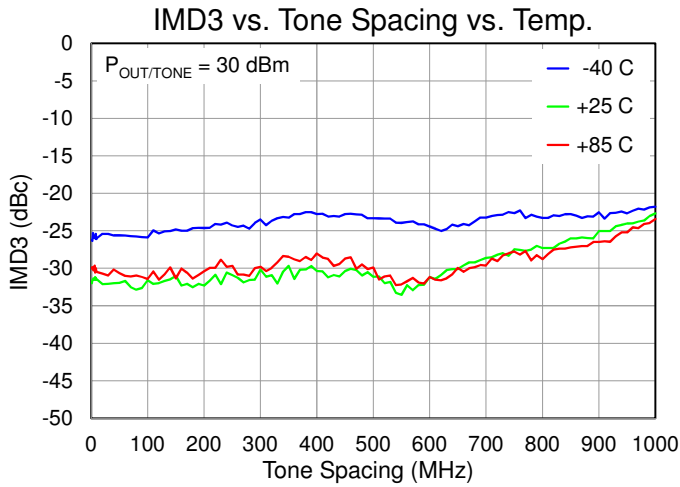

### Performance Plots – Linearity

Test conditions, unless otherwise noted: CW,  $V_D = 24\text{ V}$ ,  $I_{DQ} = 70\text{ mA}$ ,  $F_C = 40\text{ GHz}$ ,  $T_{BASE} = +25\text{ }^\circ\text{C}$  ( $T_{BASE}$  is backside of 0.02 in CuMo carrier plate)

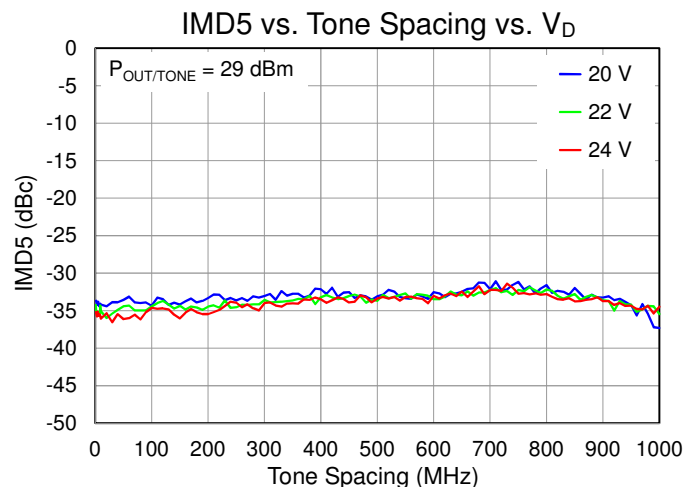
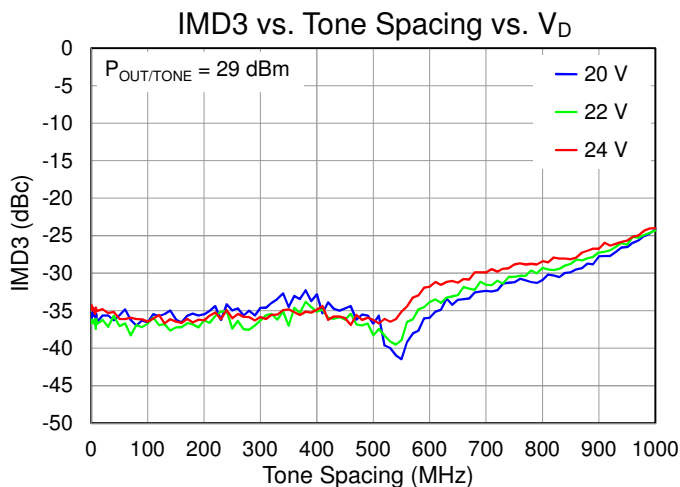
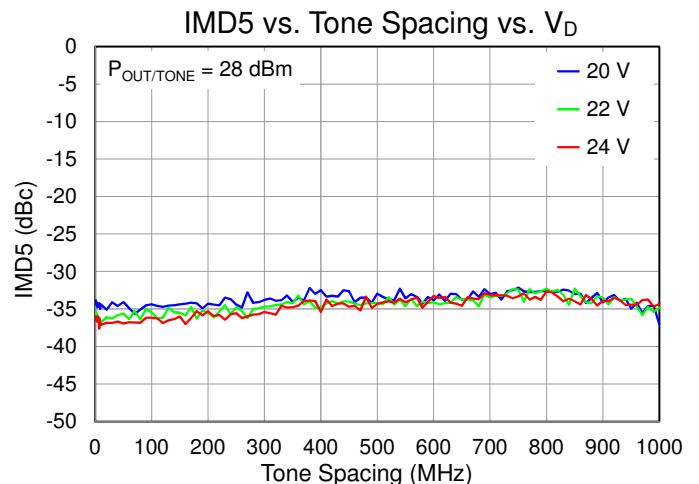
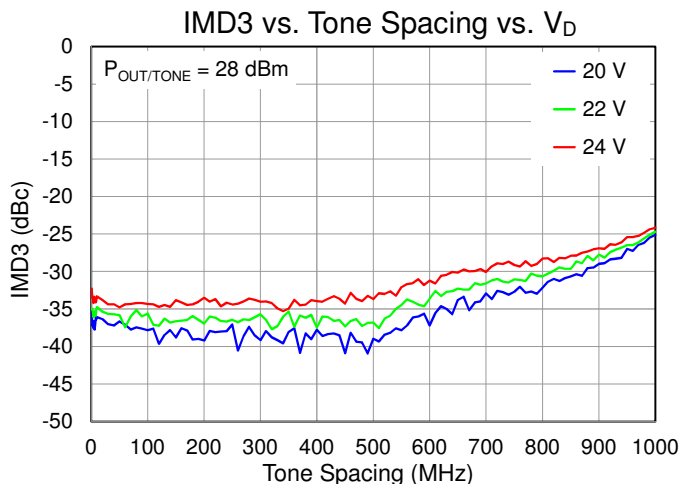
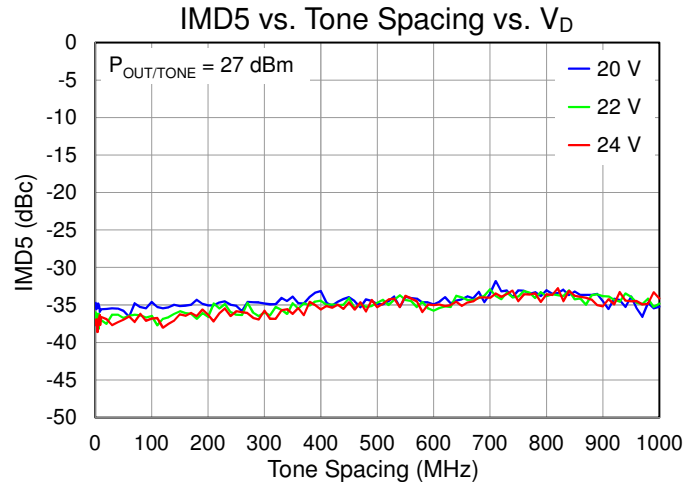
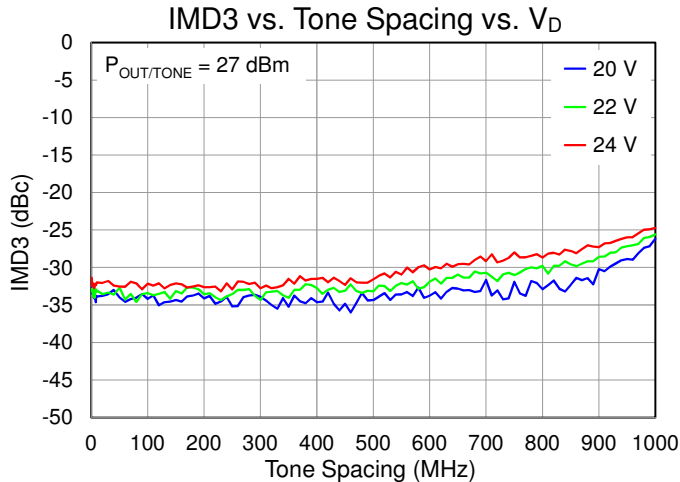

Performance Plots – Linearity

Test conditions, unless otherwise noted: CW,  $V_D = 24\text{ V}$ ,  $I_{DQ} = 70\text{ mA}$ ,  $F_C = 40\text{ GHz}$ ,  $T_{BASE} = +25\text{ }^\circ\text{C}$  ( $T_{BASE}$  is backside of 0.02 in CuMo carrier plate)

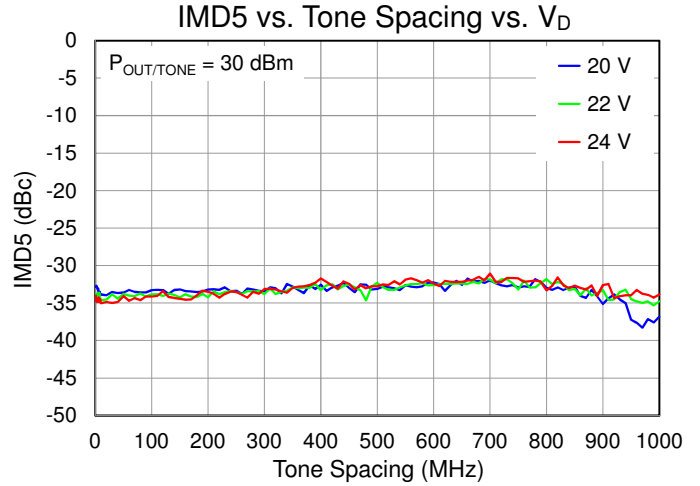
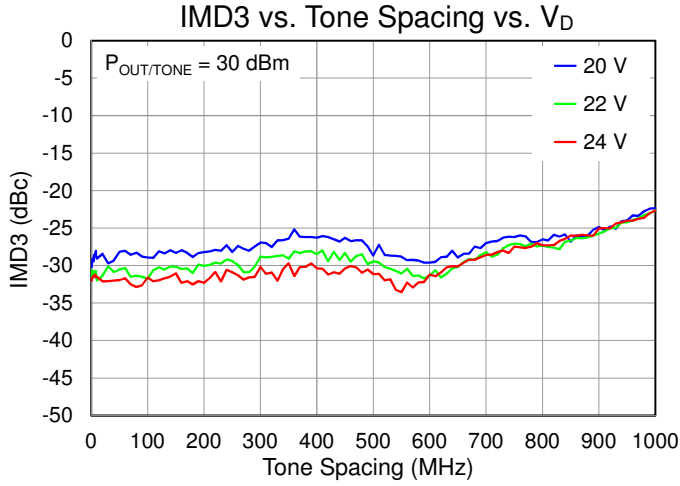

Performance Plots – Small Signal

Test conditions, unless otherwise noted: CW,  $V_D = 24\text{ V}$ ,  $I_{DQ} = 70\text{ mA}$ ,  $P_{IN} = -30\text{ dBm}$ ,  $T_{BASE} = +25\text{ }^\circ\text{C}$  ( $T_{BASE}$  is backside of 0.02 in CuMo carrier plate)

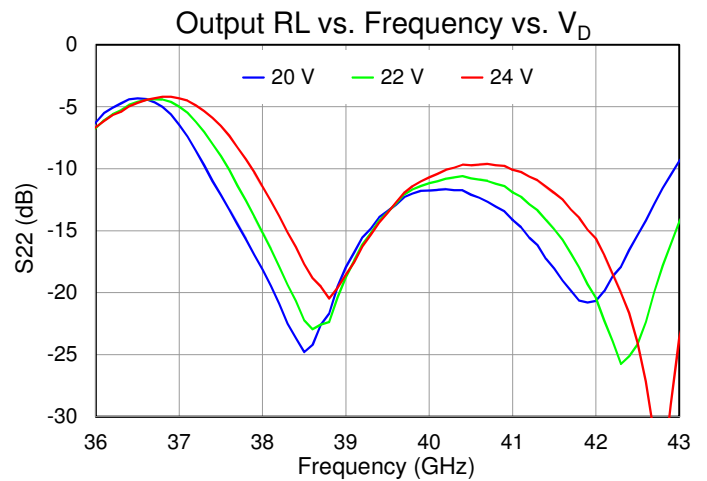
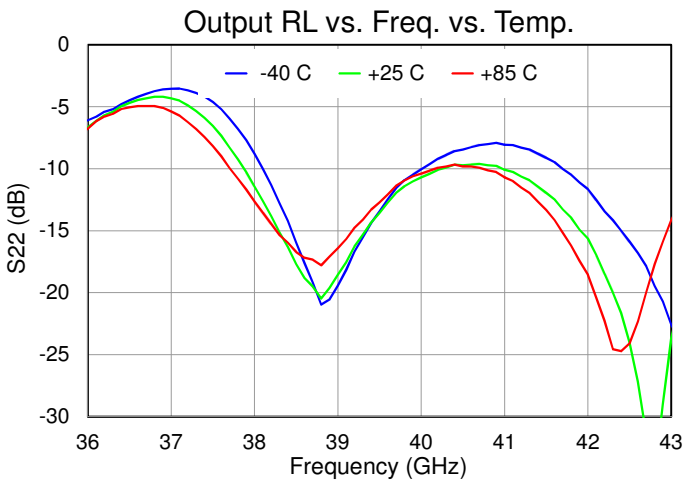
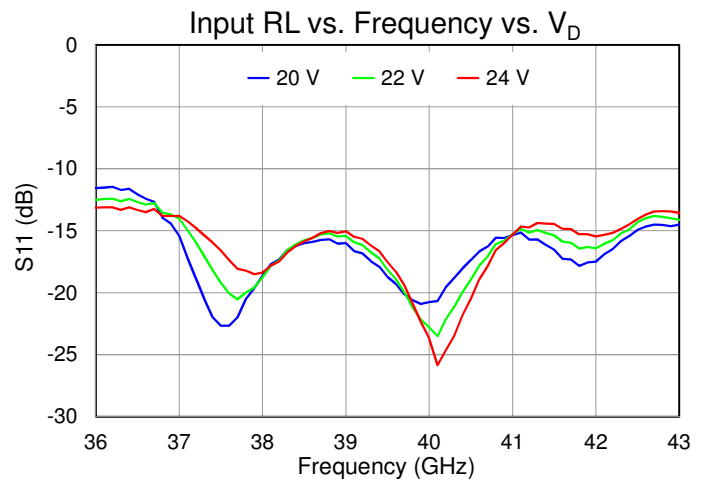
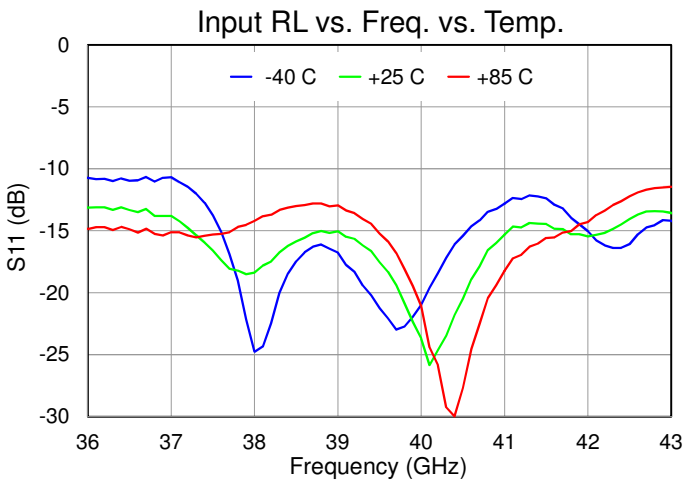
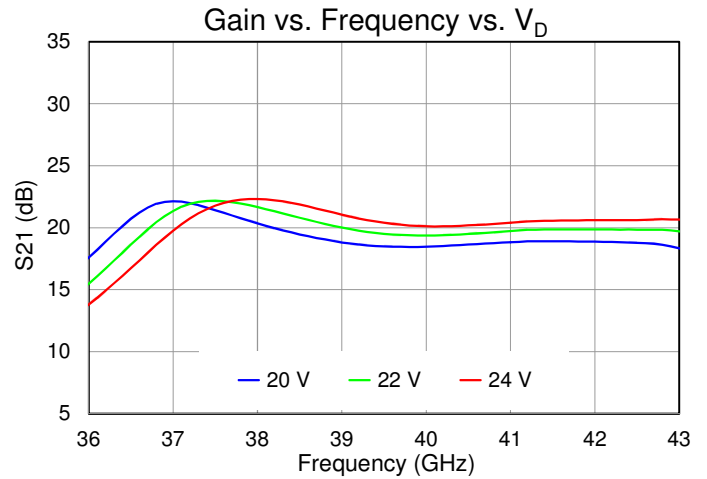
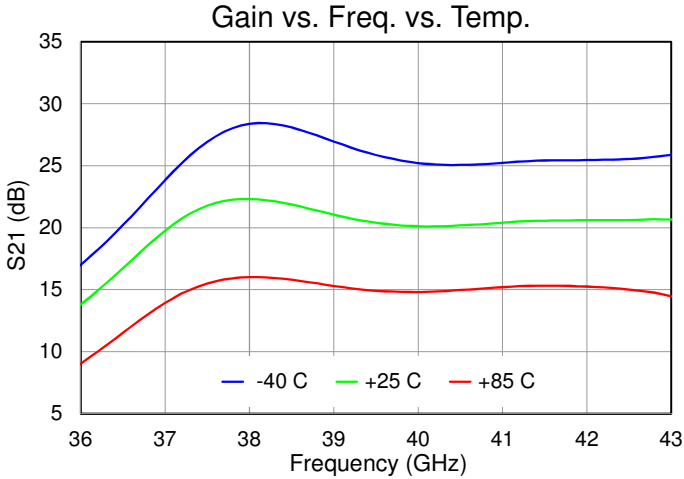

Performance Plots – Small Signal

Test conditions, unless otherwise noted: CW,  $V_D = 24\text{ V}$ ,  $I_{DQ} = 70\text{ mA}$ ,  $P_{IN} = -30\text{ dBm}$ ,  $T_{BASE} = +25\text{ }^\circ\text{C}$  ( $T_{BASE}$  is backside of 0.02 in CuMo carrier plate)

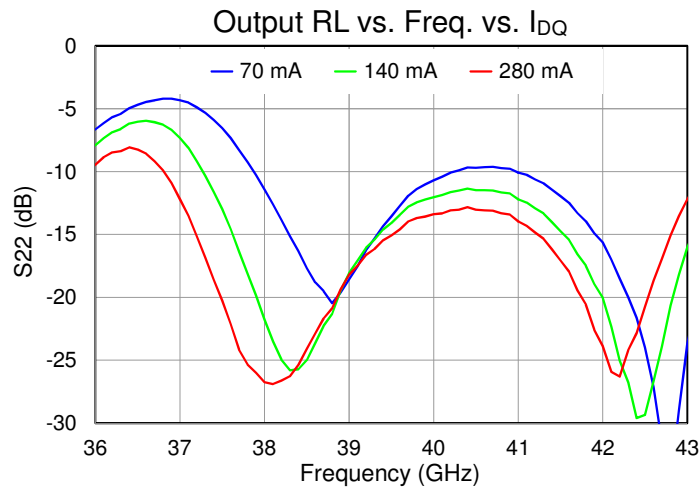
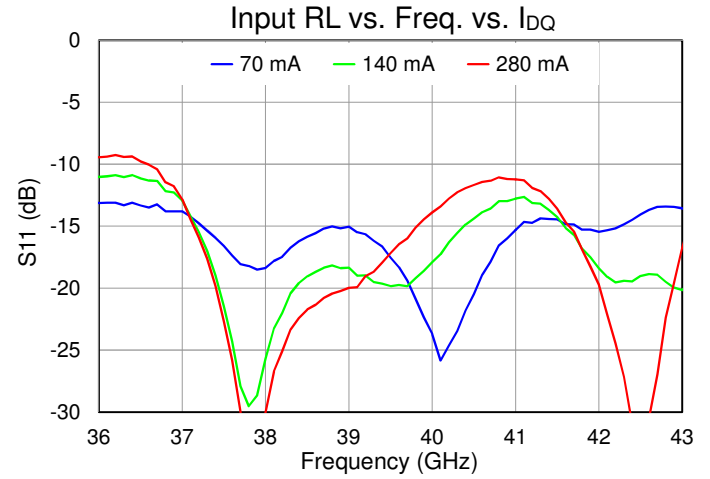
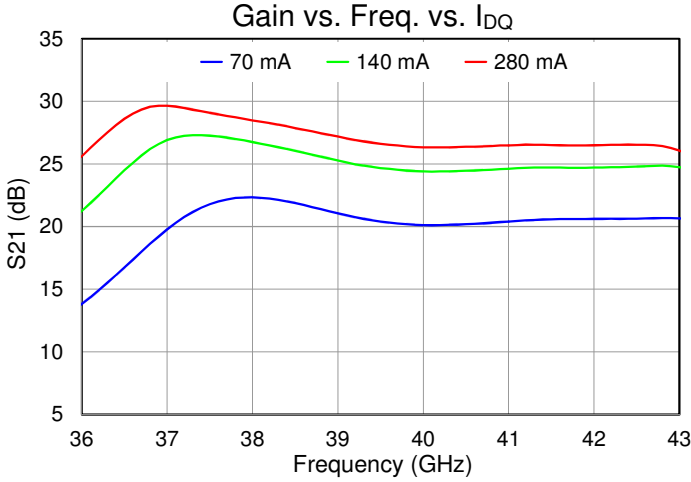

## Thermal and Reliability Information

Parameter	Test Conditions	Value	Units
Thermal Resistance, $\theta_{JC}$ <sup>(1)</sup>	Quiescent, no RF	5.20	$^{\circ}\text{C}/\text{W}$
Channel Temperature, $T_{CH}$ <sup>(2)</sup>	$T_{BASE} = 85^{\circ}\text{C}$ , $V_D = 24\text{ V}$ , $I_{DQ} = 70\text{ mA}$ , $P_{DISS} = 1.68\text{ W}$	94	$^{\circ}\text{C}$
Thermal Resistance, $\theta_{JC}$ <sup>(1)</sup>	$P_{IN} = 22\text{ dBm}$ , $T_{BASE} = 85^{\circ}\text{C}$ , CW, $V_D = 24\text{ V}$ , $I_{DQ} = 70\text{ mA}$ , Freq = 40.5 GHz, $I_{D\_DRIVE} = 665\text{ mA}$ , $P_{OUT} = 34.5\text{ dBm}$ , $P_{DISS} = 13.3\text{ W}$	5.85	$^{\circ}\text{C}/\text{W}$
Channel Temperature, $T_{CH}$ <sup>(2)</sup>		163	$^{\circ}\text{C}$
Thermal Resistance, $\theta_{JC}$ <sup>(1)</sup>	$P_{IN} = 25\text{ dBm}$ , $T_{BASE} = 85^{\circ}\text{C}$ , CW, $V_D = 24\text{ V}$ , $I_{DQ} = 70\text{ mA}$ , Freq = 40.5 GHz, $I_{D\_DRIVE} = 785\text{ mA}$ , $P_{OUT} = 35.5\text{ dBm}$ , $P_{DISS} = 15.6\text{ W}$	5.98	$^{\circ}\text{C}/\text{W}$
Channel Temperature, $T_{CH}$ <sup>(2)</sup>		178	$^{\circ}\text{C}$

Notes:

1. Thermal resistance determined to  $T_{BASE}$  ( $T_{BASE}$  is backside of 0.02 in carrier plate CuMo with AuSn die attached)
2. Channel temperature indicated is an IR scan equivalent temperature. Thermal resistance is calculated using this value. Additional information can be found in the Qorvo Applications Note "GaN Device TCHMAX Theta-JC and Reliability Estimates," located here <https://www.qorvo.com/products/d/da006480>

## Dissipated Power

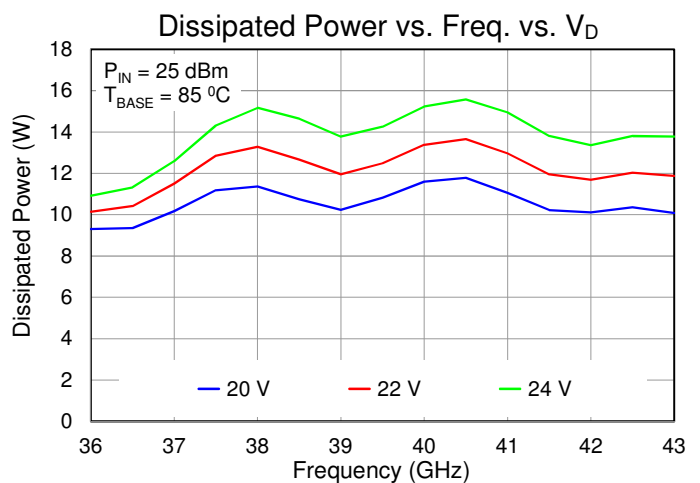
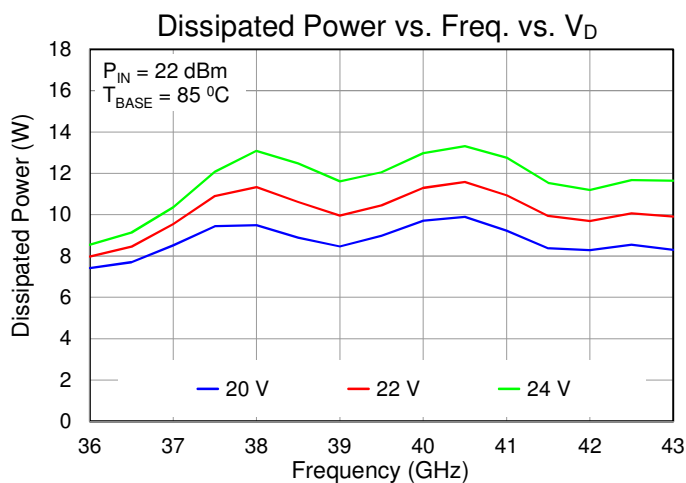

Test conditions, unless otherwise noted: CW,  $V_D = 24\text{ V}$ ,  $I_{DQ} = 70\text{ mA}$ ,  $T_{BASE} = 85^{\circ}\text{C}$   
 $T_{BASE}$  is back side of 0.02 in CuMo carrier plate with AuSn die attached

Maximum Gate Current

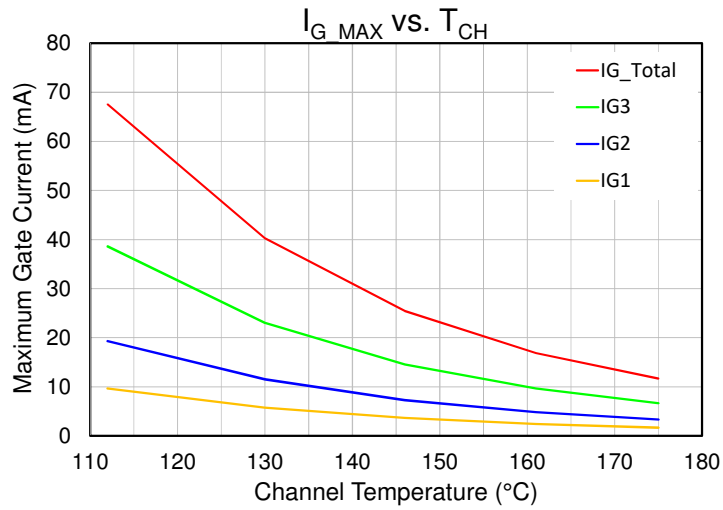

Channel Temperature is an IR scan equivalent

Applications Information

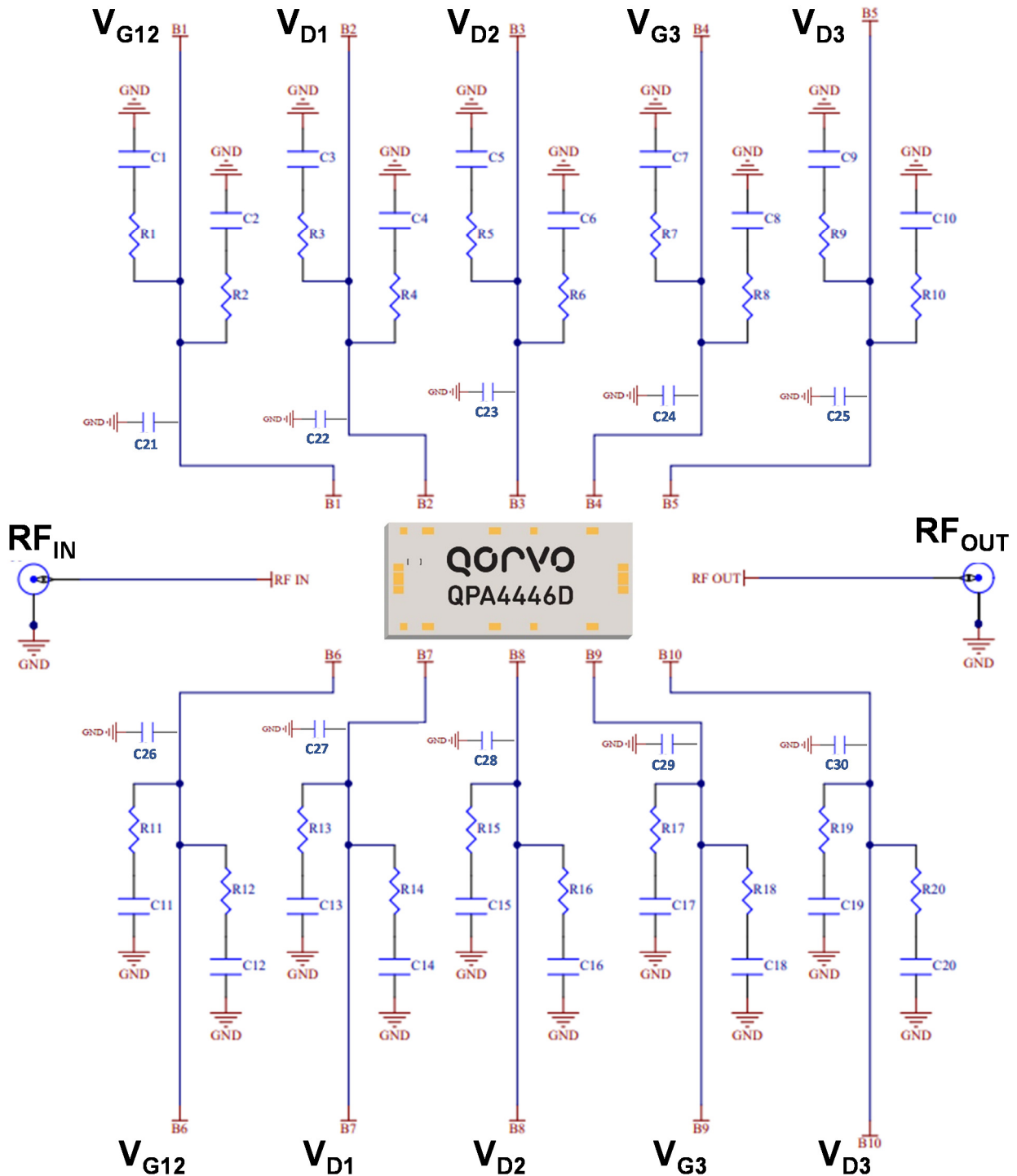

DC can be applied on top, or bottom, or both sides of the dies  
External bypassing required on both sides

Evaluation Board (EVB) Layout

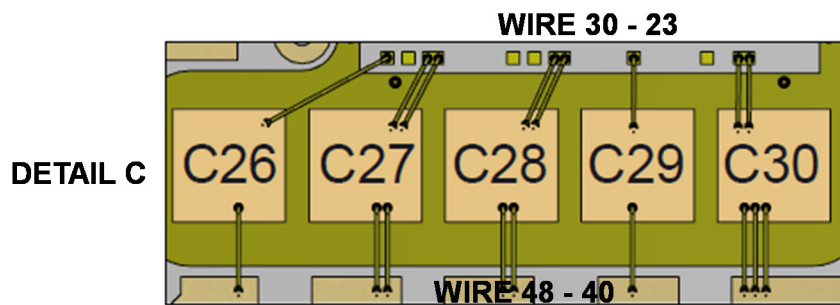
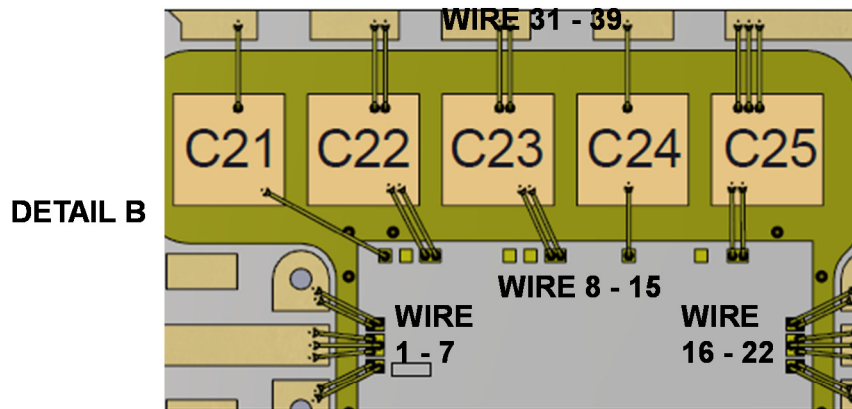
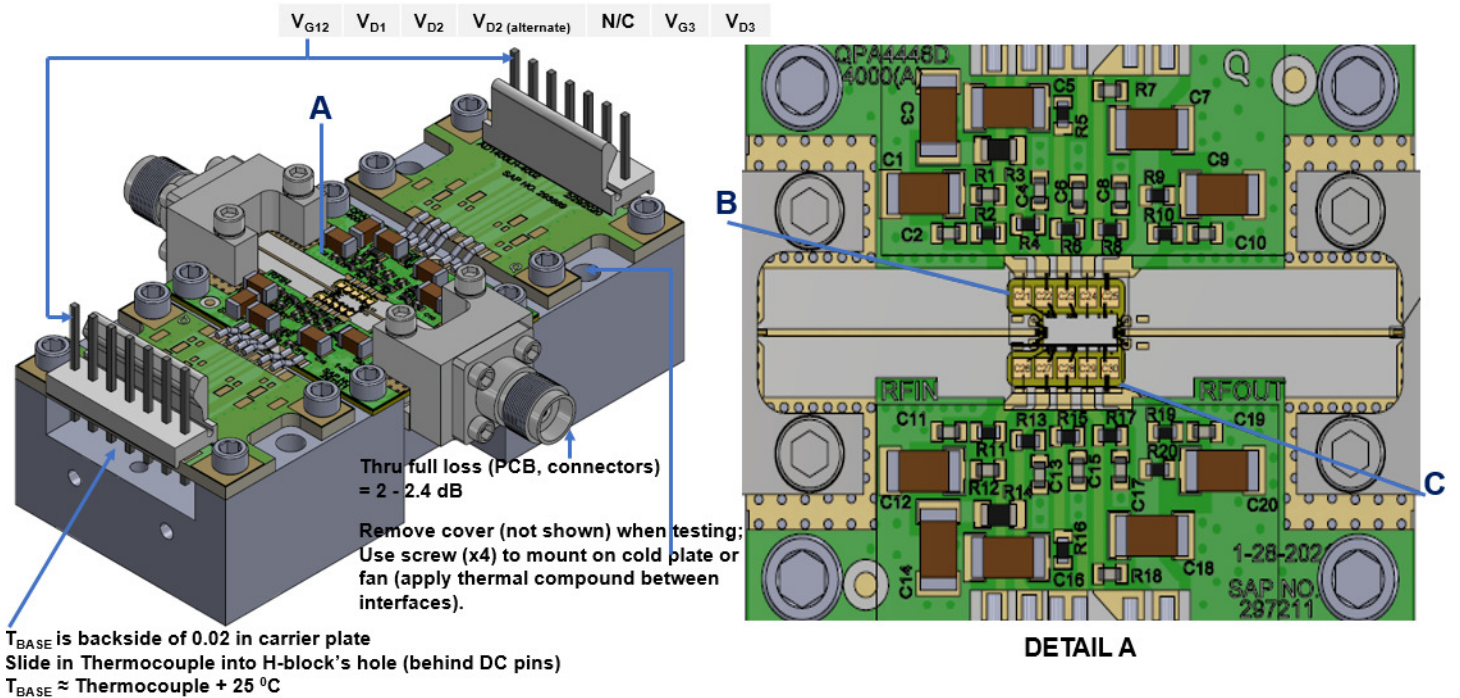

## Bill of Materials

Reference Des.	Qty	Value	Description	Part Number
C1, C3, C5, C7, C9, C12, C14, C16, C18, C20	10	10 uF	CAP, 10uF, 20%, 50V, 20%, X5R, 1206	
C2, C4, C6, C8, C10, C11, C13, C15, C17, C19	10	0.01 uF	CAP, 0.01uF, ±10%, 50V, X7R, 0402	
C21 – C30	10	10 nF	CAP, 10nF, ±15%, 30V, SLC, 0303	
R1, R7, R12, R18	4	5.1 Ω	RES, 5.1 Ohm, ±1%, 1/10W, 0402	
R2, R4 – R6, R8 – R11, R13, R15 – R17, R19, R20	14	0 Ω	RES, 0 Ohm, JMPR, 0402	
R3, R14	2	0 Ω	RES, 0 Ohm, JMPR, 0603	
PCB_MMIC	1		PCB for MMIC, Taconics TSM-S3B 0.005", 0.5oz Ni/Pd/Au plating both sides, total thickness 0.009"	Qorvo, Custom
PCB,_Bias	2		PCB for DC Bias	Qorvo, Custom
H1, H2	2		CONN, HDR, Male-vert, 7 PIN, 1 RAW, MTA	TE Connectivity 640456-7 *7 PINS*
J1, J2	2		Connector, RF 2.4mm, F, Pin 0.005, Diel 0.0295	Southwest Microwave 1092-04A-12
CP	1		Carrier Plate, CuMo, 0.9 x 1.15 x 0.02T	Qorvo, Custom
H-Block	1		H-Block, Copper C110, 1.14 x 2.49 x 0.59T	Qorvo, Custom
S1 – S4	12		Screw, Cap, Socket Head, 2-56X1/8"	
AuSn			AuSn Solder preform	
Epoxy			Epoxy preform	
Ablebond			Epoxy, Ablebond 84-1LMI	
Solder			Paste, solder, Syntech, Sn63/Pb37	
TC			Thermal Compound, Silver 5GR	Artic Silver 5 AS5-5G

## Bias-Up Procedure

1. Set  $I_D$  limit to 1.5 A,  $I_G$  limit to 20 mA
2. Set  $V_G$  to  $-3.5$  V
3. Set  $V_D +24$  V. Ensure  $I_{DQ} \sim 0$  mA
4. Adjust  $V_G$  more positive until  $I_D = 70$  mA;  
 $V_G \approx -2.3$  V +/- 0.6V typical range
5. Apply RF signal

## Bias-Down Procedure

1. Turn off RF signal
2. Reduce  $V_G$  to  $-3.5$  V. Ensure  $I_{DQ} \sim 0$  mA
3. Set  $V_D$  to 0 V
4. Turn off  $V_D$  supply
5. Turn off  $V_G$  supply

Combined  $V_D = V_{D1} + V_{D2} + V_{D3}$ ,  $V_G = V_{G12} + V_{G3}$   
 DC can be applied on top, or bottom, or both sides of the dies

Mechanical Information

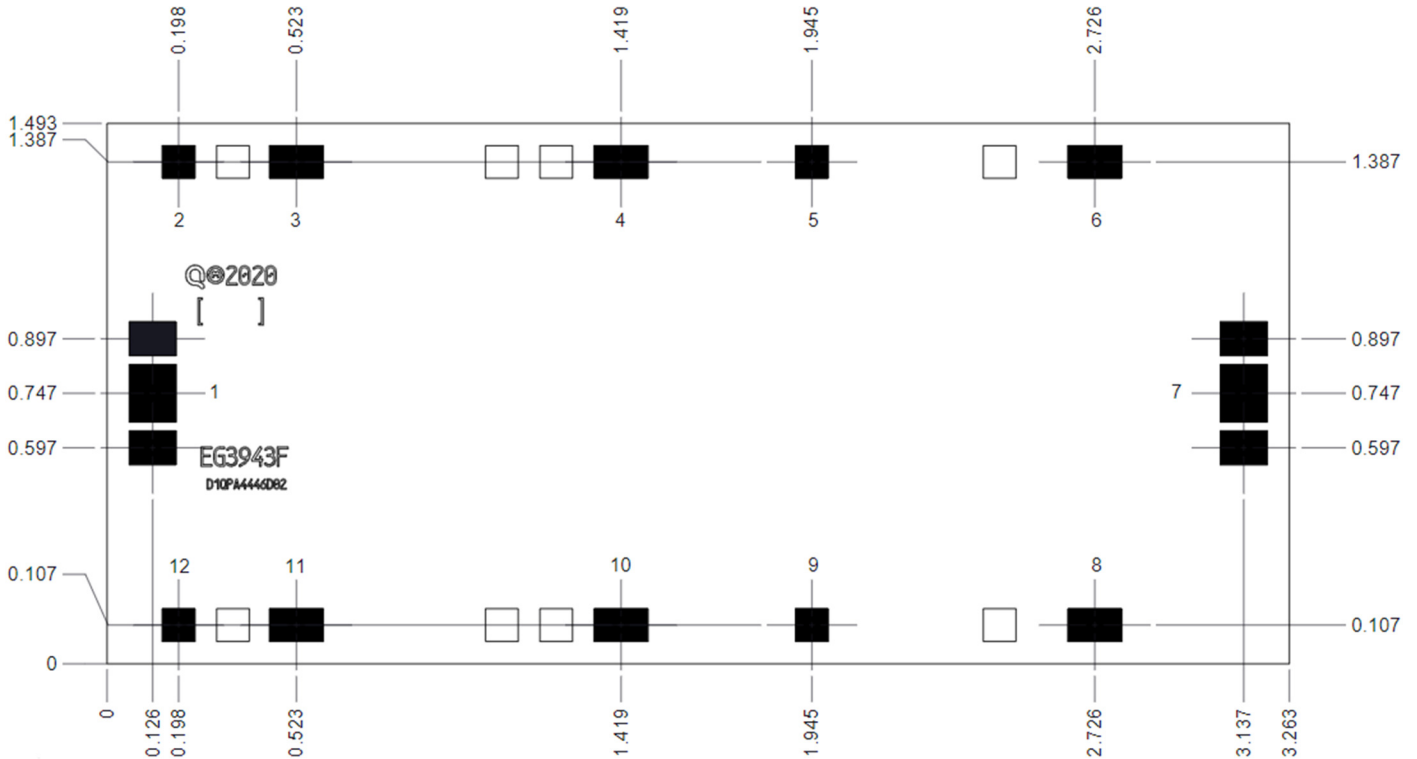

Dimensions: mm; Thickness: 0.05 mm; Die x, y size tolerance: ± 0.050; Ground is backside of die

Bond Pad Description

Pad No.	Symbol	Pad Size (mm)	Description
1	RF <sub>IN</sub>	0.13 x 0.16	RF Input. Matched to 50 Ω, DC blocked, DC shorted to ground
2, 12	V <sub>G12</sub>	0.09 x 0.09	Gate voltage for stage 1 and 2 <sup>(1)</sup>
3, 11	V <sub>D1</sub>	0.15 x 0.09	Drain voltage for stage 1 <sup>(1)</sup>
4, 10	V <sub>D2</sub>	0.15 x 0.09	Drain voltage for stage 2 <sup>(1)</sup>
5, 9	V <sub>G3</sub>	0.09 x 0.09	Gate voltage for stage 3 <sup>(1)</sup>
6, 8	V <sub>D3</sub>	0.15 x 0.09	Drain voltage for stage 3 <sup>(1)</sup>
7	RF <sub>OUT</sub>	0.13 x 0.16	RF Output. Matched to 50 Ω, DC blocked

1. External bypassing required; refer to page 26 for recommendation

## Assembly Notes

---

Component placement and adhesive attachment assembly notes:

- Vacuum pencils and/or vacuum collets are the preferred method of pick up.
- Air bridges must be avoided during placement.
- The force impact is critical during auto placement.

Reflow process assembly notes:

- Use AuSn (80/20) solder and limit exposure to temperatures above 300 °C to 3–4 minutes, maximum.
- An alloy station or conveyor furnace with reducing atmosphere should be used.
- Do not use any kind of flux.
- Coefficient of thermal expansion matching is critical for long-term reliability.
- Devices must be stored in a dry nitrogen atmosphere.

Interconnect process assembly notes:

- Thermosonic ball bonding is the preferred interconnect technique.
- Force, time, and ultrasonic are critical parameters.
- Aluminum wire should not be used.
- Devices with small pad sizes should be bonded with 0.0007-inch wire.

## Handling Precautions

Parameter	Rating	Standard
ESD – Human Body Model (HBM)	1A	ANSI/ESD/JEDEC JS-001



Caution!

ESD-Sensitive Device

## Solderability

Use only AuSn (80/20) solder, and limit exposure to temperatures above 300 °C to 3–4 minutes, maximum.

## RoHS Compliance

This part is compliant with 2011/65/EU RoHS directive (Restrictions on the Use of Certain Hazardous Substances in Electrical and Electronic Equipment) as amended by Directive 2015/863/EU.

This product also has the following attributes:

- Lead Free
- Halogen Free (Chlorine, Bromine)
- Antimony Free
- TBBP-A (C<sub>15</sub>H<sub>12</sub>Br<sub>4</sub>O<sub>2</sub>) Free
- SVHC Free
- PFOS Free

## Contact Information

For the latest specifications, additional product information, worldwide sales and distribution locations:

Web: [www.qorvo.com](http://www.qorvo.com)

Tel: 1-844-890-8163

Email: [customer.support@qorvo.com](mailto:customer.support@qorvo.com)

## Important Notice

The information contained herein is believed to be reliable; however, Qorvo makes no warranties regarding the information contained herein and assumes no responsibility or liability whatsoever for the use of the information contained herein. All information contained herein is subject to change without notice. Customers should obtain and verify the latest relevant information before placing orders for Qorvo products. The information contained herein or any use of such information does not grant, explicitly or implicitly, to any party any patent rights, licenses, or any other intellectual property rights, whether with regard to such information itself or anything described by such information. **THIS INFORMATION DOES NOT CONSTITUTE A WARRANTY WITH RESPECT TO THE PRODUCTS DESCRIBED HEREIN, AND QORVO HEREBY DISCLAIMS ANY AND ALL WARRANTIES WITH RESPECT TO SUCH PRODUCTS WHETHER EXPRESS OR IMPLIED BY LAW, COURSE OF DEALING, COURSE OF PERFORMANCE, USAGE OF TRADE OR OTHERWISE, INCLUDING THE IMPLIED WARRANTIES OF MERCHANTABILITY AND FITNESS FOR A PARTICULAR PURPOSE.**

Without limiting the generality of the foregoing, Qorvo products are not warranted or authorized for use as critical components in medical, life-saving, or life-sustaining applications, or other applications where a failure would reasonably be expected to cause severe personal injury or death.

© 2022 Qorvo US, Inc. All rights reserved. This document is subject to copyright laws in various jurisdictions worldwide and may not be reproduced or distributed, in whole or in part, without the express written consent of Qorvo US, Inc.

## Looking for pricing, stock, or lifecycle information?

Click below to explore more details on WIN SOURCE:

 [View QPA4446D on WIN SOURCE](#)

 [Qorvo US Inc. Information](#)

## Optimize Your Supply Chain with WIN SOURCE Solutions

-  Global Sourcing Solution
-  Obsolete Management
-  Cost Control Management
-  Shortage Management
-  Alternative Solution
-  Excess Inventory Management