

Product Overview

The CMD327 is a wideband GaAs MMIC low phase noise amplifier ideally suited for military, space, and communications systems. At 20 GHz the device delivers 11.1 dB of gain, has a saturated output power of +21.4 dBm, and has a noise figure of 4.5 dB. Also, with an input signal of 6 GHz, the amplifier has a very low additive phase noise of -165 dBc/Hz at 10 kHz offset. The CMD327 is a 50 ohm matched design which eliminates the need for RF port matching. The CMD327 offers full passivation for increased reliability and moisture protection.

Key Features

- Wide Bandwidth
- Low Phase Noise
- High Power
- Low Current Consumption
- Small Die Size: 2300 um x 1375 um

Ordering Information

Part No.	Description
CMD327	DC-40 GHz Low Phase Noise Amplifier, 50 Piece Gel Pack

Functional Block Diagram

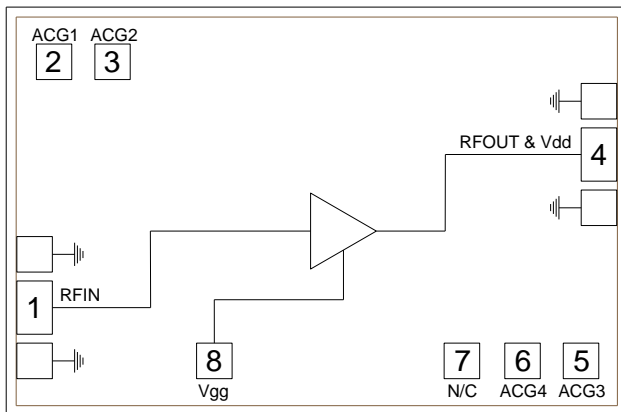

Electrical Performance ($V_{dd} = 5.0\text{ V}$, $V_{gg} = 3.0\text{ V}$, $T_A = 25\text{ }^\circ\text{C}$, $F = 20\text{ GHz}$)

Parameter	Min	Typ	Max	Units
Frequency Range		DC - 40		GHz
Gain		11.1		dB
Input Return Loss		10		dB
Output Return Loss		16		dB
Noise Figure		4.5		dB
Output P1dB		19		dBm
Saturated Output Power		21.4		dBm
Phase Noise @ 10 kHz Offset		-165		dBc/Hz
Supply Current		100		mA

Absolute Maximum Ratings

Parameter	Rating
Drain Voltage, V_{dd}	6.0 V
Gate Voltage, V_{gg}	3.6 V
RF Input Power	+20 dBm
Channel Temperature, T_{ch}	150 °C
Power Dissipation, P_{diss}	590 mW
Thermal Resistance, θ_{JC}	110 °C/W
Operating Temperature	-55 to 85 °C
Storage Temperature	-55 to 150 °C

Exceeding any one or combination of the maximum ratings may cause permanent damage to the device.

Recommended Operating Conditions

Parameter	Min	Typ	Max	Units
V_{dd}	3.0	5.0	5.5	V
I_{dd}		100		mA
V_{gg}	0	3.0	3.3	V
I_{gg}		3.6		mA

Electrical performance is measured at specific test conditions. Electrical specifications are not guaranteed over all recommended operating conditions.

Electrical Specifications ($V_{dd} = 5.0$ V, $V_{gg} = 3.0$ V, $T_A = 25$ °C)

Parameter	Min	Typ	Max	Min	Typ	Max	Units
Frequency Range	DC - 20			20 - 40			GHz
Gain	10	11		9.5	11		dB
Noise Figure		4.5			7		dB
Input Return Loss		9.5			9.5		dB
Output Return Loss		12			8.5		dB
Output P1dB	17.5	19		12.5	14		dBm
Saturated Output Power		22			16		dBm
Output IP3		31			27		dBm
Phase Noise @ 10 kHz Offset		-165			-165		dBc/Hz
Supply Current	75	100	125	75	100	125	mA

Typical Performance

Broadband Performance, $V_{dd} = 5.0\text{ V}$, $V_{gg} = 3.0\text{ V}$, $I_{dd} = 100\text{ mA}$, $T_A = 25\text{ °C}$

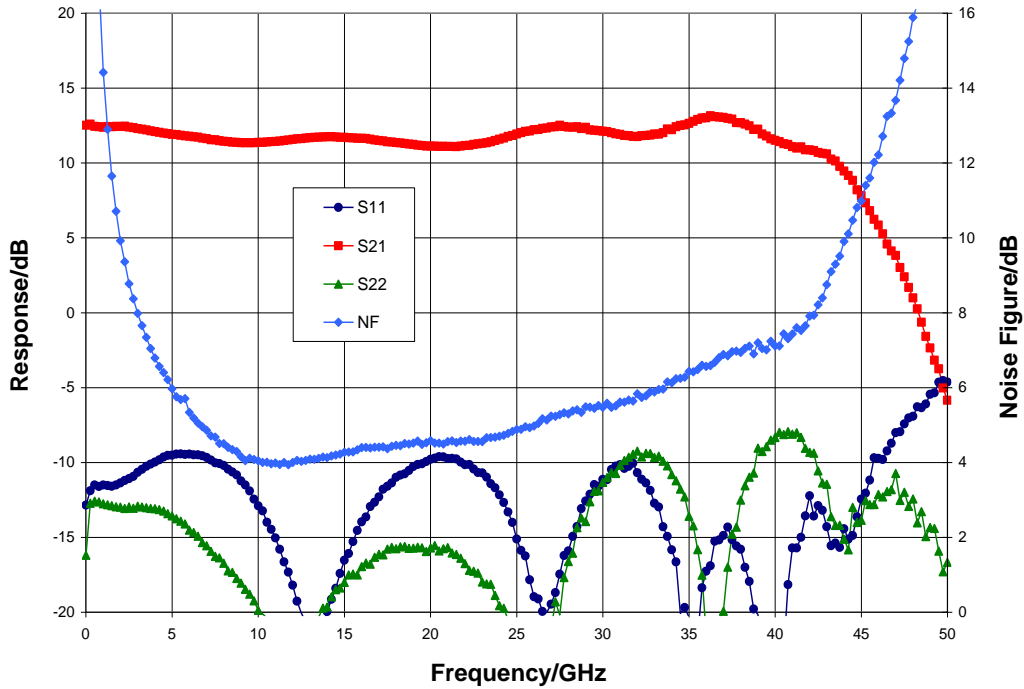

Narrow-band Performance, $V_{dd} = 5.0\text{ V}$, $V_{gg} = 3.0\text{ V}$, $I_{dd} = 100\text{ mA}$, $T_A = 25\text{ °C}$

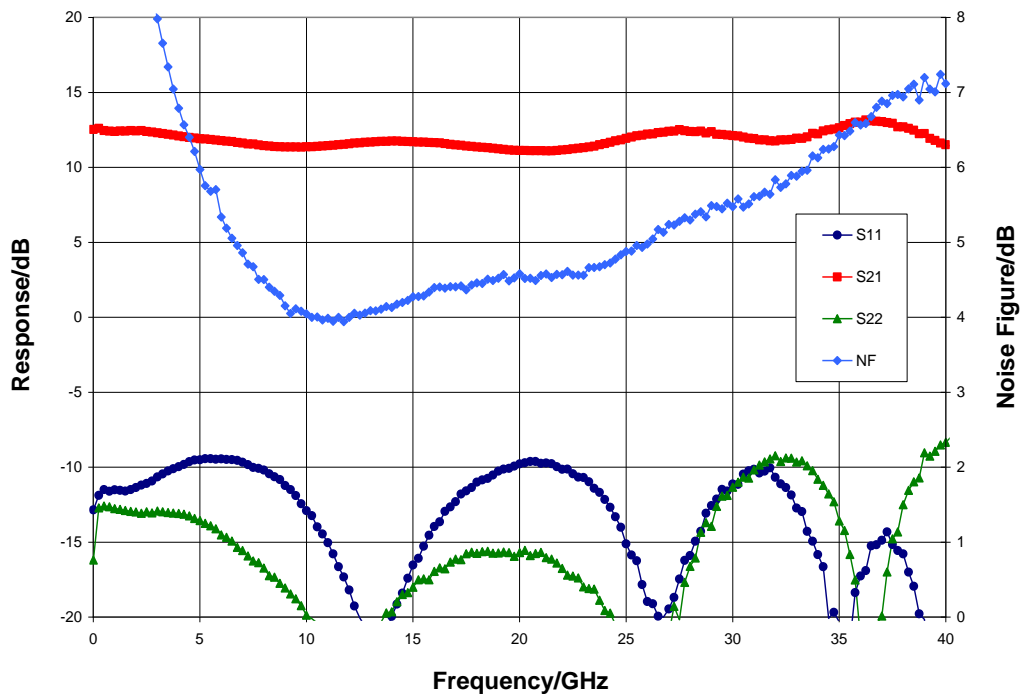

Typical Performance

Additive Phase Noise @ Psat, V_{dd} = 5.0 V, V_{gg} = 3.0 V, T_A = 25 °C, F = 6 GHz

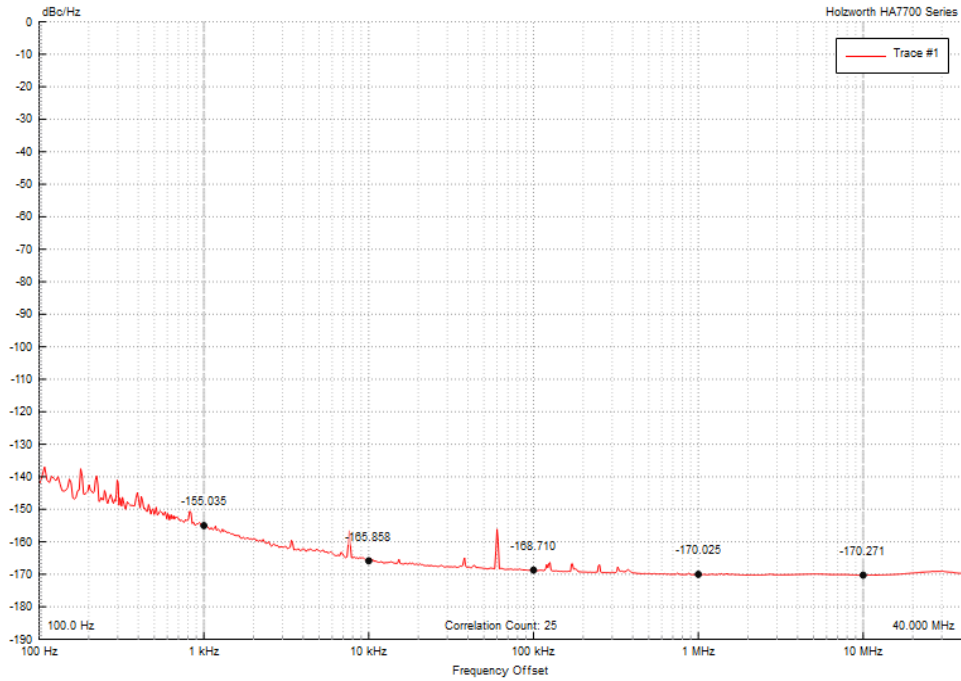

Gain vs. Temperature, V_{dd} = 5.0 V, V_{gg} = 3.0 V

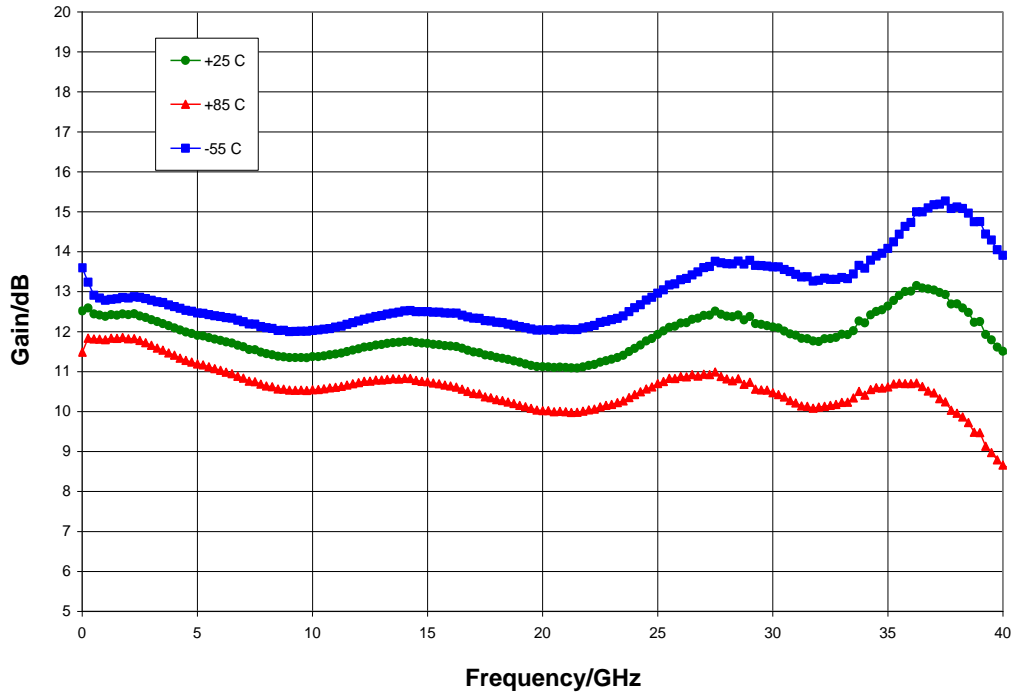

Typical Performance

Output Power, $V_{dd} = 5.0\text{ V}$, $V_{gg} = 3.0\text{ V}$, $T_A = 25\text{ }^\circ\text{C}$

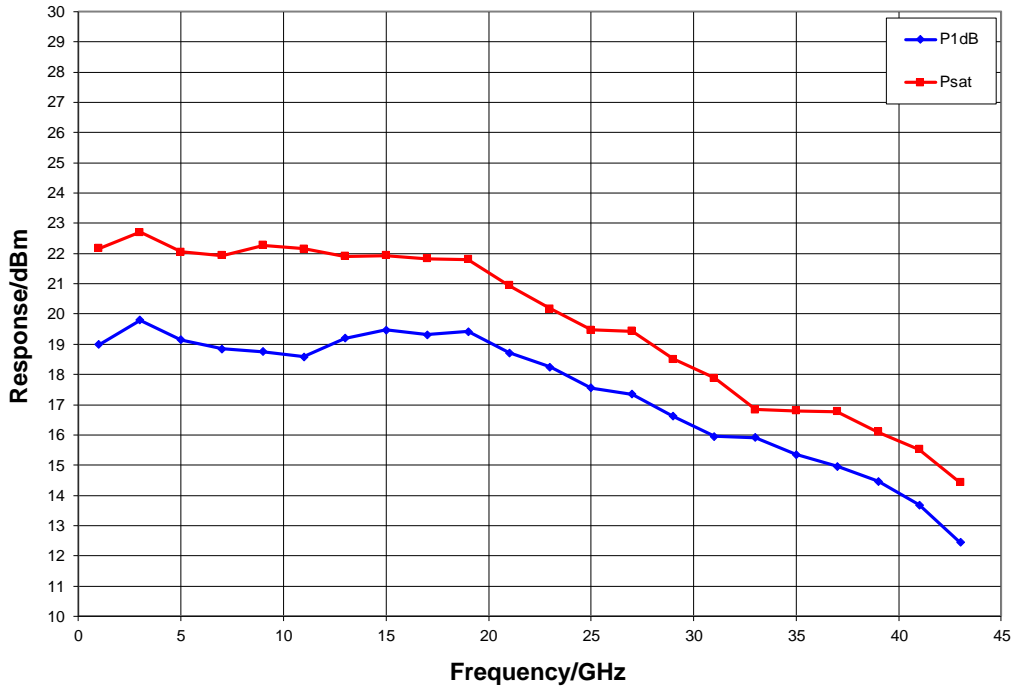

Psat vs. Temperature, $V_{dd} = 5.0\text{ V}$, $V_{gg} = 3.0\text{ V}$

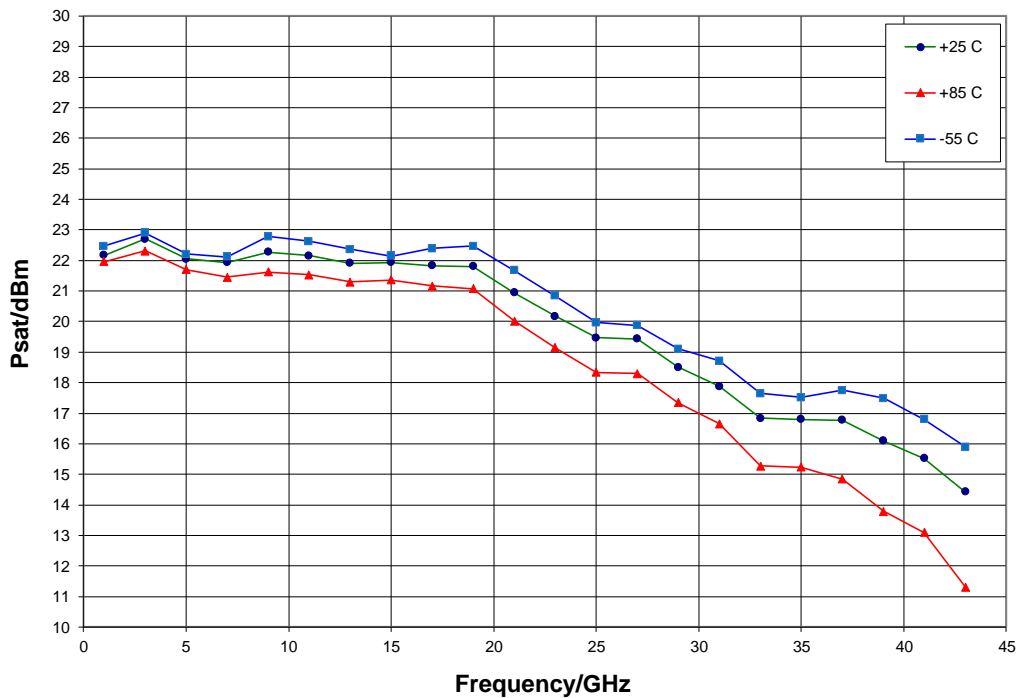

Typical Performance

Output IP3 vs. Temperature, $V_{dd} = 5.0\text{ V}$, $V_{gg} = 3.0\text{ V}$

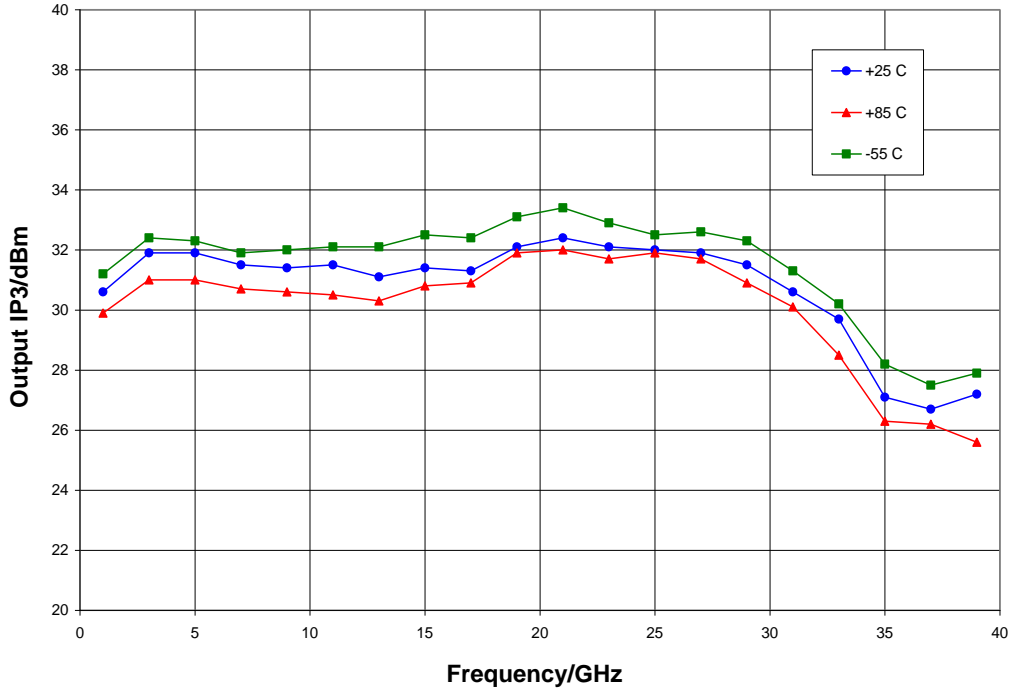

Noise Figure vs. Temperature, $V_{dd} = 5.0\text{ V}$, $V_{gg} = 3.0\text{ V}$

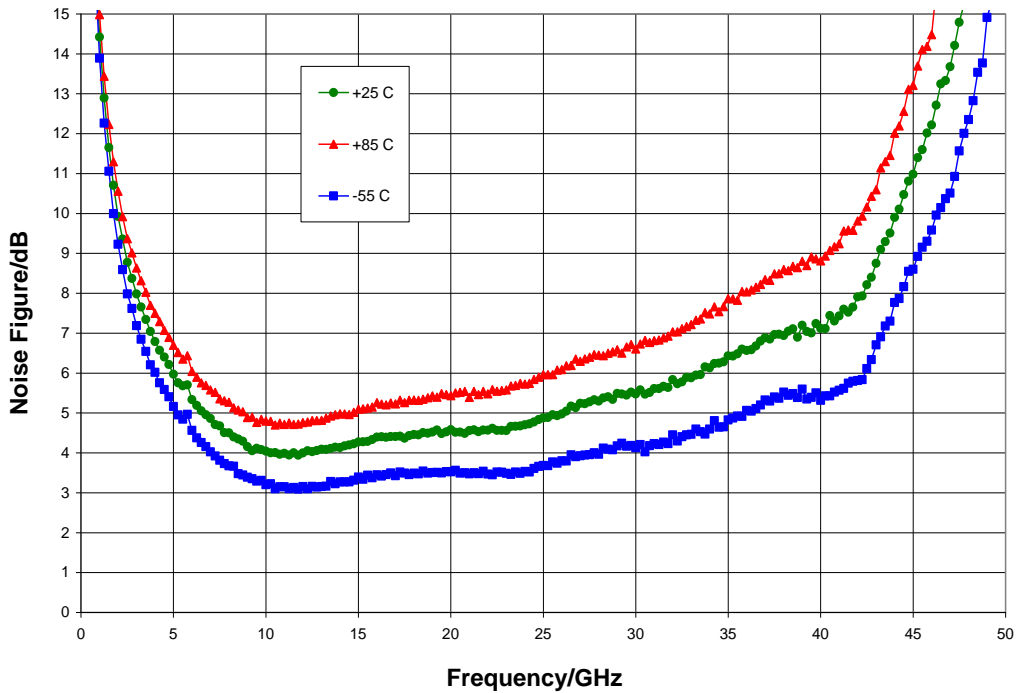

Mechanical Information

Die Outline (all dimensions in microns)

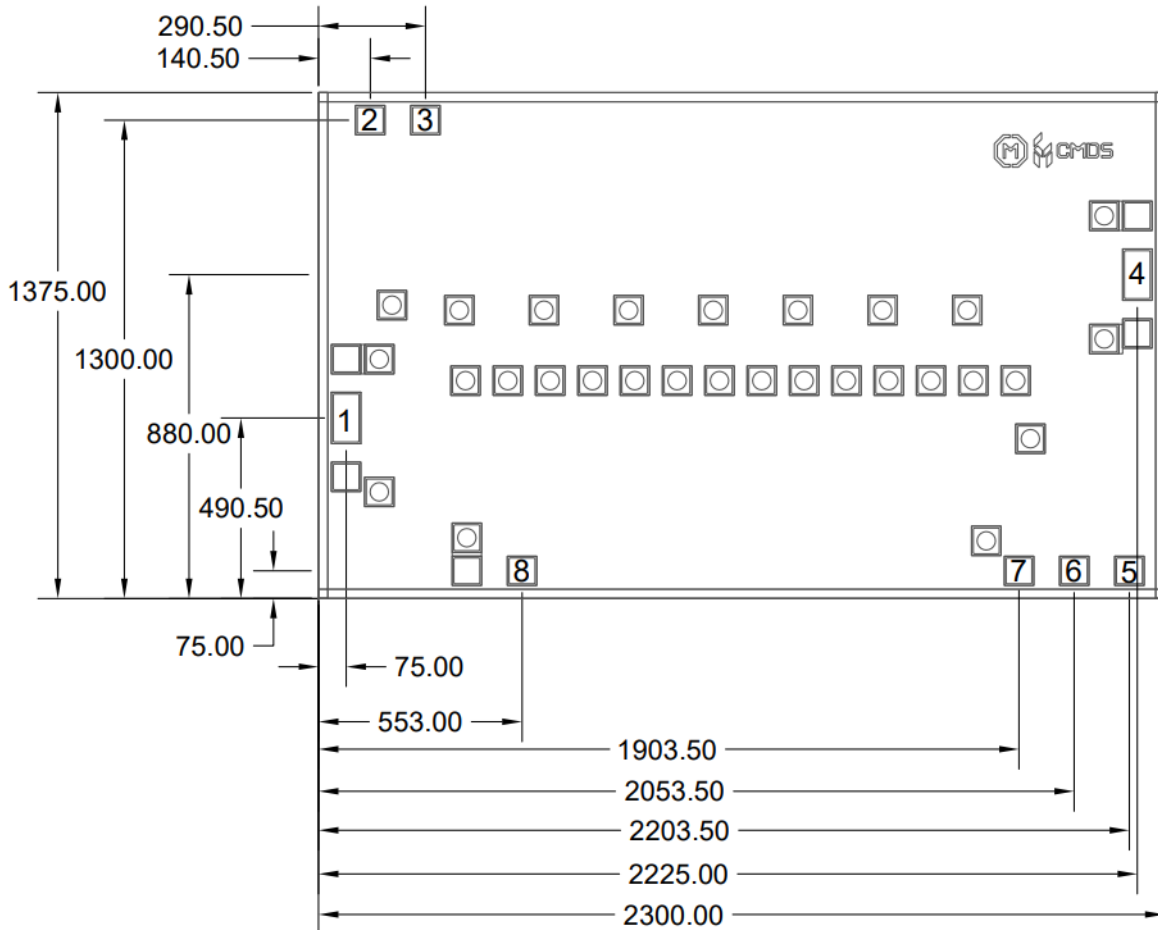

Notes:

1. No connection required for unlabeled pads
2. Backside is RF and DC ground
3. Backside and bond pad metal: Gold
4. Die is 100 microns thick
5. DC bond pads (2, 3, 5, 6, 7, 8) are 80 x 80 microns
6. RF bond pads (1, 4) are 80 x 140 microns

Pad Description

Pad Diagram

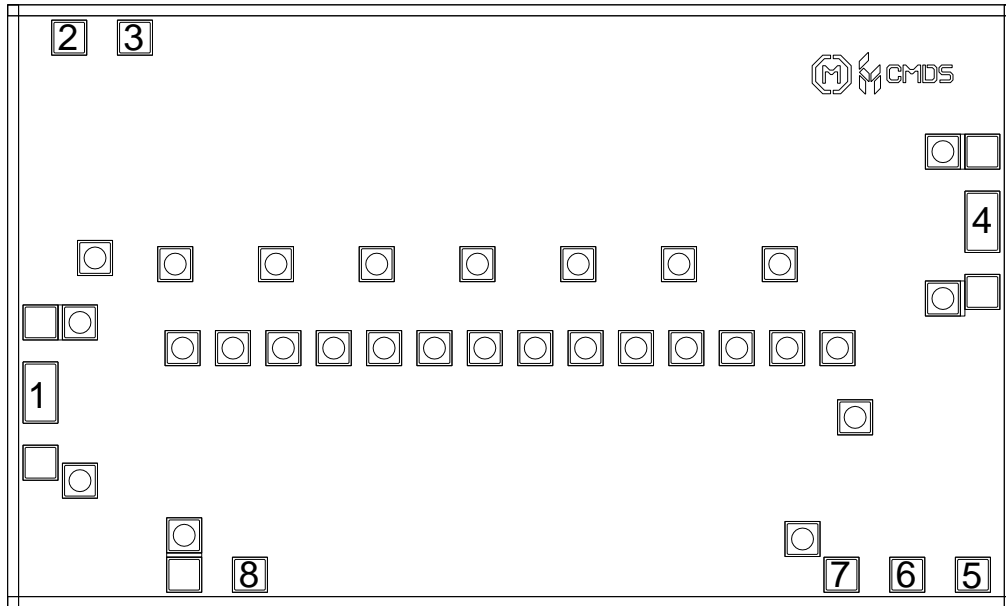

Functional Description

Pin	Function	Description	Schematic
1	RF in	50 ohm matched input	
2, 3	ACG1, 2	Low frequency termination Attach bypass capacitors per application circuit	
4	RF out & V _{dd}	Power supply voltage and 50 ohm matched output	
5, 6	ACG3, 4	Low frequency termination Attach bypass capacitors per application circuit	
7	N/C	Do not connect	
8	V _{gg}	Power supply voltage Decoupling and bypass caps required	
Backside	Ground	Connect to RF / DC ground	

Applications Information

Assembly Guidelines

The backside of the CMD327 is RF ground. Die attach should be accomplished with electrically and thermally conductive epoxy only. Eutectic attach is not recommended. Standard assembly procedures should be followed for high frequency devices. The top surface of the semiconductor should be made planar to the adjacent RF transmission lines, and the RF decoupling capacitors placed in close proximity to the DC connections on chip.

RF connections should be made as short as possible to reduce the inductive effect of the bond wire. Use of a 0.8 mil thermosonic wedge bonding is highly recommended as the loop height will be minimized. The RF input and output require a double bond wire as shown.

The semiconductor is 100 μm thick and should be handled by the sides of the die or with a custom collet. Do not make contact directly with the die surface as this will damage the monolithic circuitry. Handle with care.

Assembly Diagram

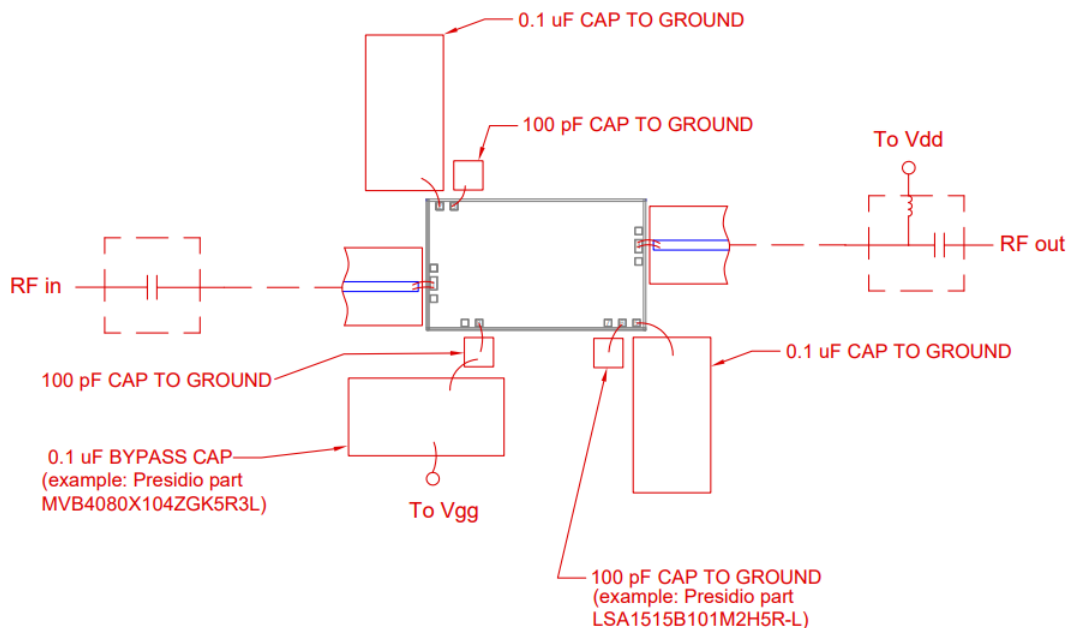

GaAs MMIC devices are susceptible to damage from Electrostatic Discharge. Proper precautions should be observed during handling, assembly and test.

Applications Information

Biasing and Operation

The CMD327 is biased with a positive drain supply and positive gate supply. Performance is optimized when the drain voltage is set to +5.0 V. The recommended gate voltage is +3.0 V. Note that the turn ON and turn OFF sequence as described below is recommended but not required.

Turn ON procedure:

1. Apply drain voltage V_{dd} and set to +5 V
2. Apply gate voltage V_{gg} and set to +3 V

Turn OFF procedure:

1. Turn off gate voltage V_{gg}
2. Turn off drain voltage V_{dd}

Refer to Application Note 103: Amplifier Biasing Techniques for instructions on how to implement a single supply biasing scheme.

RF power can be applied at any time.

Handling Precautions

Parameter	Rating	Standard
ESD – Human Body Model (HBM)	Class 1A	ESDA / JEDEC JS-001-2012



Caution!
 ESD-Sensitive Device

RoHS Compliance

This part is compliant with 2011/65/EU RoHS directive (Restrictions on the Use of Certain Hazardous Substances in Electrical and Electronic Equipment) as amended by Directive 2015/863/EU.

This product also has the following attributes:

- Lead Free
- Antimony Free
- TBBP-A (C₁₅H₁₂Br₄O₂) Free
- SVHC Free
- Halogen Free
- PFOS Free

Contact Information

For the latest specifications, additional product information, worldwide sales and distribution locations:

Web: www.qorvo.com

Tel: 1-844-890-8163

Email: customer.support@qorvo.com

Important Notice

The information contained in this Data Sheet and any associated documents (“Data Sheet Information”) is believed to be reliable; however, Qorvo makes no warranties regarding the Data Sheet Information and assumes no responsibility or liability whatsoever for the use of said information. All Data Sheet Information is subject to change without notice. Customers should obtain and verify the latest relevant Data Sheet Information before placing orders for Qorvo® products. Data Sheet Information or the use thereof does not grant, explicitly, implicitly or otherwise any rights or licenses to any third party with respect to patents or any other intellectual property whether with regard to such Data Sheet Information itself or anything described by such information.

DATA SHEET INFORMATION DOES NOT CONSTITUTE A WARRANTY WITH RESPECT TO THE PRODUCTS DESCRIBED HEREIN, AND QORVO HEREBY DISCLAIMS ANY AND ALL WARRANTIES WITH RESPECT TO SUCH PRODUCTS WHETHER EXPRESS OR IMPLIED BY LAW, COURSE OF DEALING, COURSE OF PERFORMANCE, USAGE OF TRADE OR OTHERWISE, INCLUDING THE IMPLIED WARRANTIES OF MERCHANTABILITY AND FITNESS FOR A PARTICULAR PURPOSE. Without limiting the generality of the foregoing, Qorvo® products are not warranted or authorized for use as critical components in medical, life-saving, or life-sustaining applications, or other applications where a failure would reasonably be expected to cause severe personal injury or death. Applications described in the Data Sheet Information are for illustrative purposes only. Customers are responsible for validating that a particular product described in the Data Sheet Information is suitable for use in a particular application.

© 2022 Qorvo US, Inc. All rights reserved. This document is subject to copyright laws in various jurisdictions worldwide and may not be reproduced or distributed, in whole or in part, without the express written consent of Qorvo US, Inc. | QORVO® is a registered trademark of Qorvo US, Inc.

Looking for pricing, stock, or lifecycle information?

Click below to explore more details on WIN SOURCE:

 [View CMD327 on WIN SOURCE](#)

 [Qorvo US Inc. Information](#)

Optimize Your Supply Chain with WIN SOURCE Solutions

-  Global Sourcing Solution
-  Obsolete Management
-  Cost Control Management
-  Shortage Management
-  Alternative Solution
-  Excess Inventory Management