

Balance Matching BAND PASS FILTER

1. Characteristics (at -40~+85 °C)

Tentative Part Number	LFB18868MBG9E212	
Unbalance Port Impedance (Nominal)	50 Ω(Nominal)	
Balance Port Impedance (Nominal)	Conjugate match to TI CC1310	
Center Frequency	f1	863.00 MHz ~ 876.00MHz
	f2	902.00 MHz ~ 928.00MHz
Insertion Loss in BW	1.90 dB max. at 25 °C	
	2.10 dB max. at -40 ~ +85 °C	
Attenuation (Absolute value)	20.0 dB min. at 1726.00 ~ 1856.00 MHz 40.0 dB min. at 2589.00 ~ 2784.00 MHz 33.0 dB min. at 3452.00 ~ 3712.00 MHz	
Unbalance Port V.S.W.R.in BW.	1.90 max.	
Balance Port V.S.W.R.in BW	2.10 max.	
Amplitude Balance	3.5 dB max	
Phase Differential	180+/-15.0 deg.	
Power Capacity	500 mW max.	

2. Construction, Dimensions & Marking 3. Land Pattern

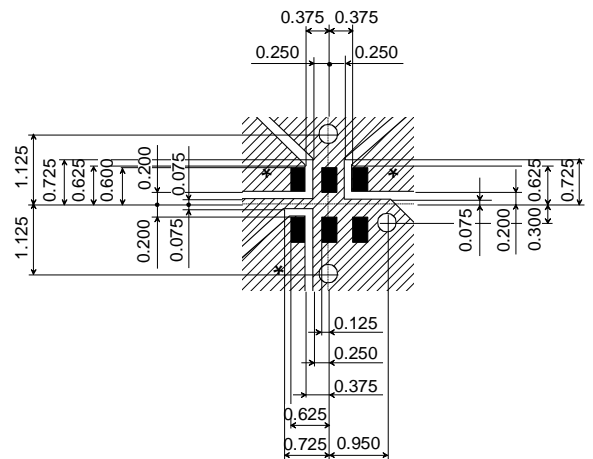
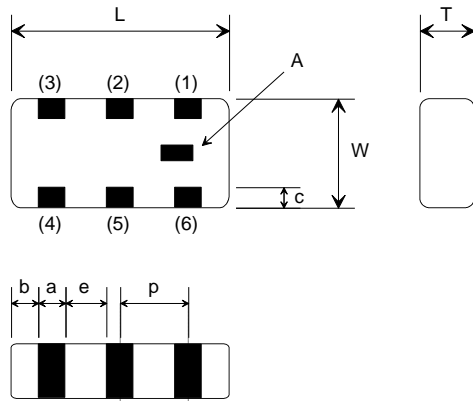

Mark	Meaning
A	Directional Input Mark

(in mm)

Mark	Dimension	Mark	Dimension	Mark	Dimension
L	1.6±0.1	a	0.2±0.1	e	0.3±0.1
W	0.8±0.1	b	0.20+0.10/-0.15	p	0.50±0.05
T	0.65 max.	c	0.15±0.10	-	-

TERMINAL CONFIGURATION

Terminal No.	Terminal Name	Terminal No.	Terminal Name
(1)	Unbalance Port	(4)	Balance Port
(2)	GND(DC feed)	(5)	GND
(3)	Balance Port	(6)	GND

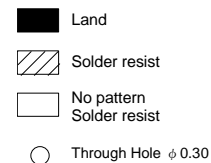

*Line width to be designed to match 50Ω characteristic impedance, depending on PCB material and thickness.

■ Measurement S-parameters

< Insertion Loss & Attenuation >

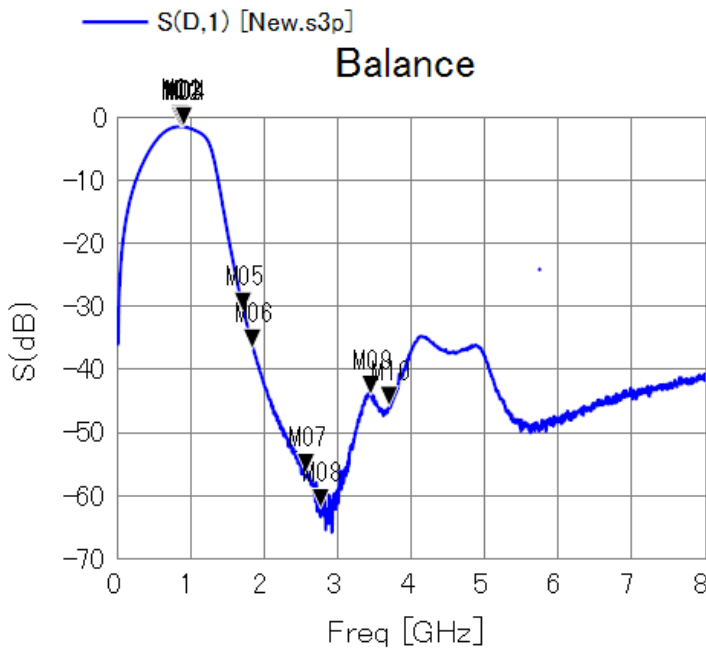

M01 : S(D,1) [New.s3p] Freq 863.000M Hz S(dB) -1.467	M02 : S(D,1) [New.s3p] Freq 876.000M Hz S(dB) -1.478
M03 : S(D,1) [New.s3p] Freq 902.000M Hz S(dB) -1.504	M04 : S(D,1) [New.s3p] Freq 928.000M Hz S(dB) -1.550

M05 : S(D,1) [New.s3p] Freq 1.726G Hz S(dB) -31.012	M06 : S(D,1) [New.s3p] Freq 1.856G Hz S(dB) -36.894
---	---

M07 : S(D,1) [New.s3p] Freq 2.589G Hz S(dB) -56.757	M08 : S(D,1) [New.s3p] Freq 2.784G Hz S(dB) -62.270
---	---

M09 : S(D,1) [New.s3p] Freq 3.452G Hz S(dB) -44.326	M10 : S(D,1) [New.s3p] Freq 3.712G Hz S(dB) -45.976
---	---

< Return Loss & Impedance >

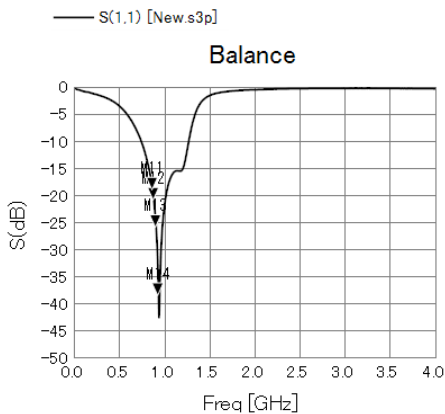

M11 : S(1,1) [New.s3p] Freq 863.000M Hz S(dB) -19.055	M12 : S(1,1) [New.s3p] Freq 876.000M Hz S(dB) -20.897
---	---

M13 : S(1,1) [New.s3p] Freq 902.000M Hz S(dB) -26.003	M14 : S(1,1) [New.s3p] Freq 928.000M Hz S(dB) -38.526
---	---

S(1,1) [New.s3p]

S parameter

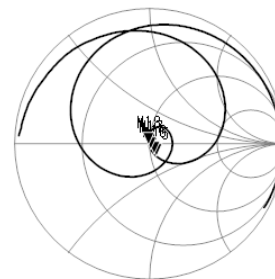

Freq (0.01GHz to 4.00GHz)

M15 : S(1,1) [New.s3p] Freq 863.000M Hz Z = 54.883 - j10.694 Ohm
M16 : S(1,1) [New.s3p] Freq 876.000M Hz Z = 53.369 - j8.737 Ohm
M17 : S(1,1) [New.s3p] Freq 902.000M Hz Z = 51.066 - j4.967 Ohm
M18 : S(1,1) [New.s3p] Freq 928.000M Hz Z = 49.646 - j1.132 Ohm

< Amplitude Balance >

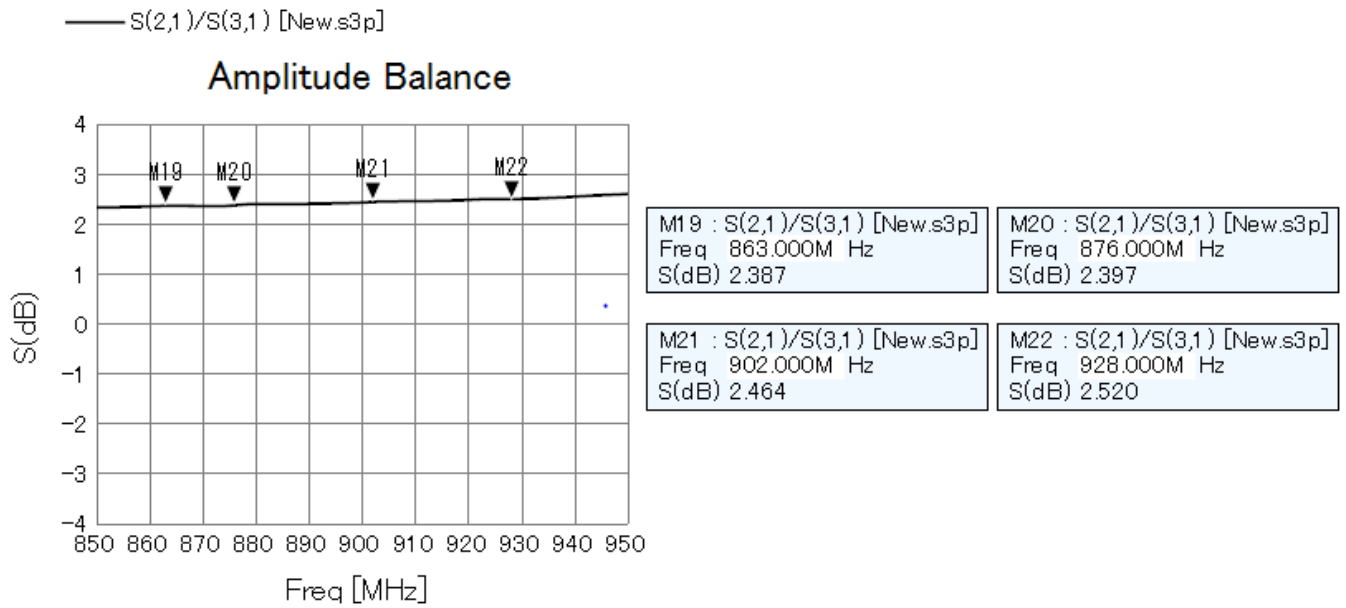

< Phase Balance >

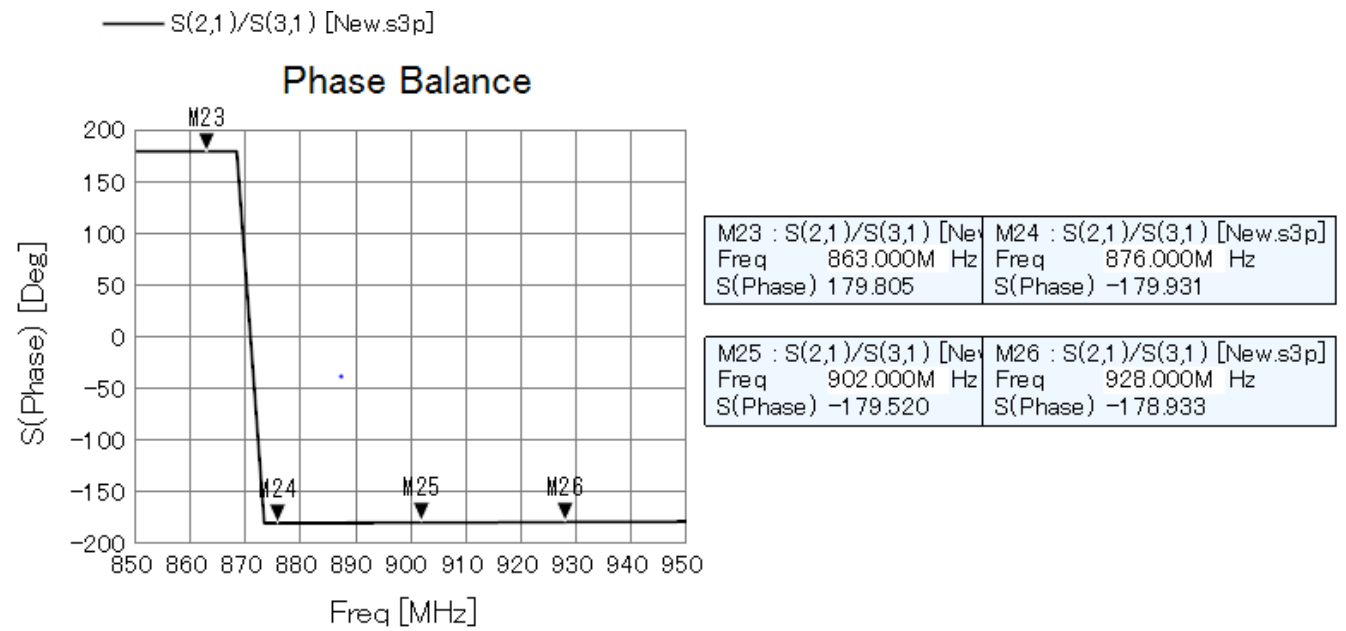

 **CAUTION**

PLEASE READ THIS NOTICE BEFORE USING OUR PRODUCTS.

Please make sure that your product has been evaluated and confirmed from the aspect of the fitness for the specifications of our product when our product is mounted to your product.

All the items and parameters in this product specification/datasheet/catalog have been prescribed on the premise that our product is used for the purpose, under the condition and in the environment specified in this specification. You are requested not to use our product deviating from the condition and the environment specified in this specification.

Please note that the only warranty that we provide regarding the products is its conformance to the specifications provided herein. Accordingly, we shall not be responsible for any defects in products or equipment incorporating such products, which are caused under the conditions other than those specified in this specification.

WE HEREBY DISCLAIMS ALL OTHER WARRANTIES REGARDING THE PRODUCTS, EXPRESS OR IMPLIED, INCLUDING WITHOUT LIMITATION ANY WARRANTY OF FITNESS FOR A PARTICULAR PURPOSE, THAT THEY ARE DEFECT-FREE, OR AGAINST INFRINGEMENT OF INTELLECTUAL PROPERTY RIGHTS.

The product shall not be used in any application listed below which requires especially high reliability for the prevention of such defect as may directly cause damage to the third party's life, body or property. You acknowledge and agree that, if you use our products in such applications, we will not be responsible for any failure to meet such requirements.

Furthermore, YOU AGREE TO INDEMNIFY AND DEFEND US AND OUR AFFILIATES AGAINST ALL CLAIMS, DAMAGES, COSTS, AND EXPENSES THAT MAY BE INCURRED, INCLUDING WITHOUT LIMITATION, ATTORNEY FEES AND COSTS, DUE TO THE USE OF OUR PRODUCTS IN SUCH APPLICATIONS.

- Aircraft equipment.
- Undersea equipment.
- Medical equipment.
- Traffic signal equipment.
- Burning / explosion control equipment
- Application of similar complexity and/ or reliability requirements to the applications listed in the above.
- Aerospace equipment
- Power plant control equipment
- Transportation equipment (vehicles, trains, ships, elevator, etc.).
- Disaster prevention / crime prevention equipment.

We expressly prohibit you from analyzing, breaking, Reverse-Engineering, remodeling altering, and reproducing our product. Our product cannot be used for the product which is prohibited from being manufactured, used, and sold by the regulations and laws in the world.

We do not warrant or represent that any license, either express or implied, is granted under any our patent right, copyright, mask work right, or our other intellectual property right relating to any combination, machine, or process in which our products or services are used. Information provided by us regarding third-party products or services does not constitute a license from us to use such products or services or a warranty or endorsement thereof. Use of such information may require a license from a third party under the patents or other intellectual property of the third party, or a license from us under our patents or other intellectual property.

Please do not use our products, our technical information and other data provided by us for the purpose of developing of mass-destruction weapons and the purpose of military use.

Moreover, you must comply with "foreign exchange and foreign trade law", the "U.S. export administration regulations", etc.

Please note that we may discontinue the manufacture of our products, due to reasons such as end of supply of materials and/or components from our suppliers.

Customer acknowledges that Murata will, if requested by you, conduct a failure analysis for defect or alleged defect of Products only at the level required for consumer grade Products, and thus such analysis may not always be available or be in accordance with your request (for example, in cases where the defect was caused by components in Products supplied to Murata from a third party).

By signing on specification sheet or approval sheet, you acknowledge that you are the legal representative for your company and that you understand and accept the validity of the contents herein.

When you are not able to return the signed version of specification sheet or approval sheet within 90 days from receiving date of specification sheet or approval sheet, it shall be deemed to be your consent on the content of specification sheet or approval sheet.

Customer acknowledges that engineering samples may deviate from specifications and may contain defects due to their development status.

We reject any liability or product warranty for engineering samples.

In particular we disclaim liability for damages caused by

- the use of the engineering sample other than for evaluation purposes, particularly the installation or integration in the product to be sold by you,

- deviation or lapse in function of engineering sample,
- improper use of engineering samples.



We disclaims any liability for consequential and incidental damages.

If you can't agree the above contents, you should inquire our sales.

All the technical data and information contained herein are subject to change without prior notice.

Looking for pricing, stock, or lifecycle information?

Click below to explore more details on WIN SOURCE:

-  [View LFB18868MBG9E212 on WIN SOURCE](#)
-  [Murata Electronics North America Information](#)

Optimize Your Supply Chain with WIN SOURCE Solutions

-  Global Sourcing Solution
-  Obsolete Management
-  Cost Control Management
-  Shortage Management
-  Alternative Solution
-  Excess Inventory Management