

MMA-212734D-M5 21-27GHz, 3W Power Amplifier

Features:

- Frequency Range: 21 – 27 GHz
- Psat: 34 dBm
- IM3 Level -40dBc @Po=20dBm/tone
- Gain: 25 dB
- Vdd =6 V
- Ids = 1500 to 2800 mA
- Input and Output Fully Matched to 50 Ω
- Integrated RF power detector

Applications:

- Communication systems
- Microwave instrumentations
- Point to Point Radios

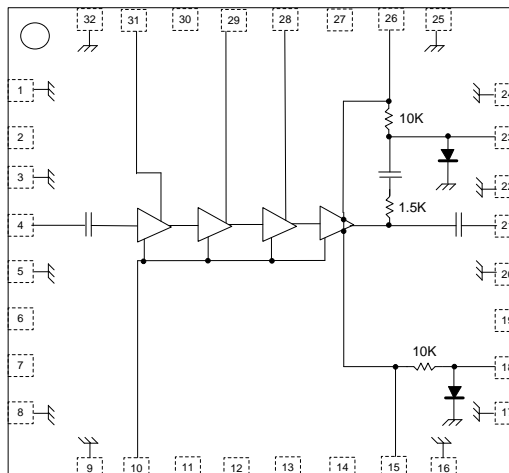

Functional Block Diagram

Description:

The MMA-212734D-M5 is a GaAs MMIC linear power amplifier with 3-Watt output power and high gain of 25dB over full 21 to 27GHz frequency range. This amplifier was optimally designed for high linearity applications at 12dB back-off from P-1 condition.

Absolute Maximum Ratings: $(T_a = 25\text{ }^\circ\text{C})^*$

SYMBOL	PARAMETERS	UNITS	Min.	Max.
Vds	Drain-Source Voltage	V		6.5
Vg	Gate-Source Voltage	V	-2.1	0
Ig	First Gate Current	mA	-17	17
Pd	Power Dissipation	W		16.8
Pin max	RF Input Power	dBm		20
Tch	Channel Temperature	°C		+150
Tstg	Storage Temperature	°C		-55 to +150
Tmax	Max. Assembly Temp (20 sec max)	°C		+250

*Operation of this device above any one of these parameters may cause permanent damage.

MMA-212734D-M5

21-27GHz, 3W Power Amplifier

Electrical Specifications: *V_{ds}=6V, I_{ds}=2000mA, T_a=25 °C Z₀=50 ohm*

Parameter	Units	Typical Data
Frequency Range	GHz	21-27
Gain (Typ/Min)	dB	25 / 24
Gain Flatness (Typ/Max)	+/-dB	1 / 1.5
Input RL(Typ/Max)	dB	15/12
Output RL (Typ/Max)	dB	15/12
Output P1dB (Typ/Min)	dBm	33/32
IM3 Level @Po=20dBm/tone ⁽¹⁾	dBc	-40
Output Psat (Typ/Min)	dBm	34/33
Operating Current at P1dB (Typ/Max)	mA	2000 / 2500
Thermal Resistance	°C/W	3.8
Operating Temperature Range	°C	-40 to +85

(1) Output IM3 is measured with two tones at output power of 20 dBm/tone separated by 20 MHz.

MMA-212734D-M5

21-27GHz, 3W Power Amplifier

Typical RF Performance: $V_{ds}=6V$, $I_{ds}=2000mA$, $Z_0=50\ \Omega$, $T_a=25\ ^\circ C$

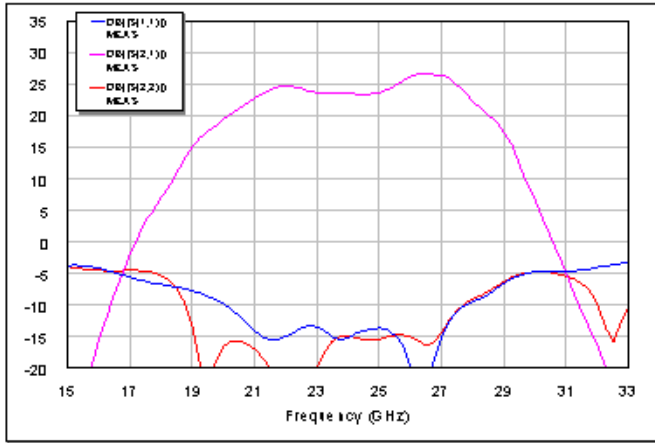

S11[dB], S21[dB], and S22[dB] vs. Frequency

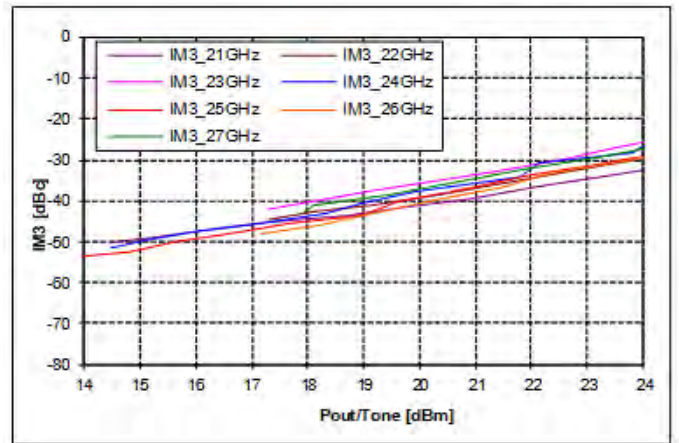

IM3 Level vs. single tone output power [dBm/ton]

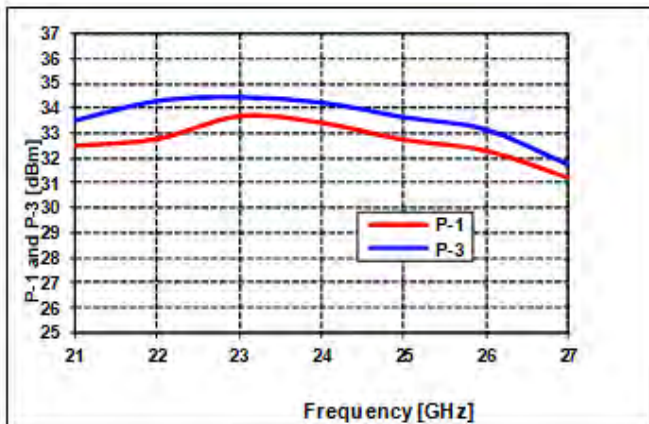

P-1 and Psat vs. Frequency

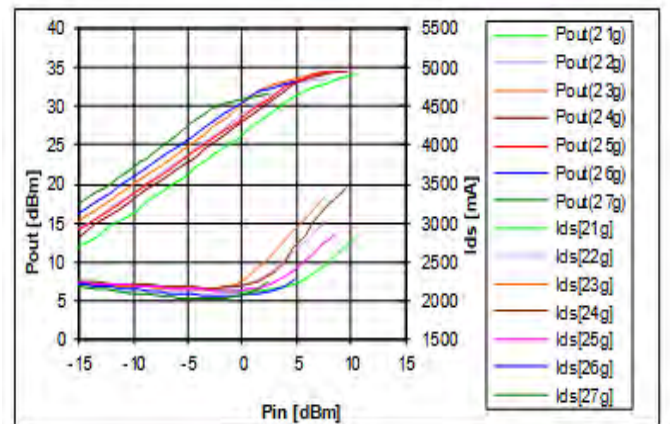

Pout [dBm], and Ids [mA] vs. Input power [dBm]

Typical Power Detector Voltages: $V_{ds}=6V$, $I_{dsq}=2A$, Frequency=22GHz

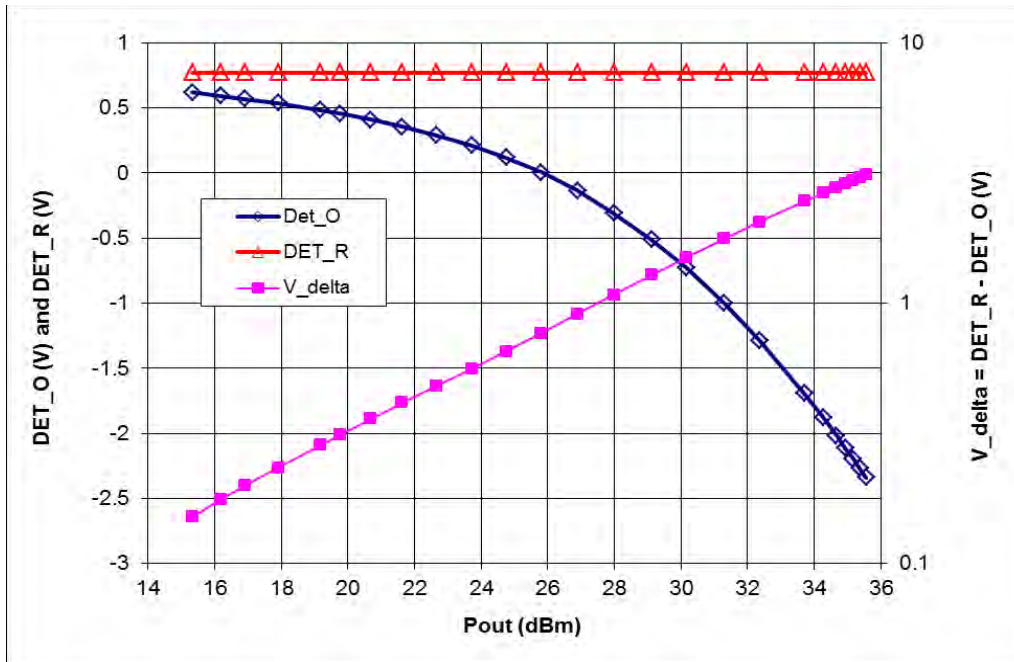

Detector Voltages (DET_O and DET_R) vs. Output RF power

Vdelta axis is Log-scale.

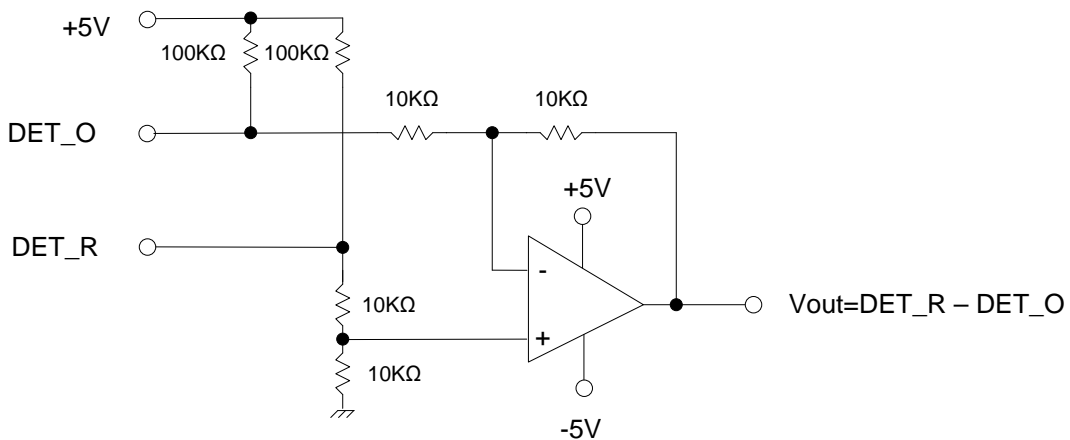

Applications

The **MMA-212734D-M5** MMIC power amplifier is designed for use as a power stage amplifier in microwave transmitters. It is ideally suited for 21 to 27GHz band point to point radio applications requiring a flat gain response and excellent linearity performance. This amplifier is provided as a 5x5mm QFN package, and the packaged amplifier is fully compatible with industry standard high volume surface mount PCB assembly processes.

Biassing and Operation

The recommended bias conditions for best performance for the **MMA-212734D-M5** are $V_{DD} = 6.0V$, $I_{dsq} = 2000mA$. Performance improvements are possible depending on applications. The drain bias voltage range is 5 to 6V and the quiescent drain current biasing range is 1500mA to 2800mA. A single DC gate supply connected to V_g will bias all the amplifier stages. Muting can be accomplished by setting V_g to the pinch-off voltage ($V_p = -2V$). The gate voltage (V_g) should be applied prior to the drain voltages (V_{d1} , V_{d2} , V_{d3} , V_{d4}) during power up and removed after the drain voltages during power down. The RF input and output ports are DC decoupled internally. Typical DC supply connection with bi-passing capacitors for the **MMA-212734D-M5** is shown in following pages.

MMA-212734D-M5 contains optional temperature compensated output power detectors. Typical detection voltage vs. output power is shown in previous page. To obtain over temperature compensation, a recommended differential amplifier is required.

Assembly Techniques

GaAs MMICs are ESD sensitive. ESD preventive measures must be employed in all aspects of storage, handling, and assembly. MMIC ESD precautions, handling considerations, die attach and bonding methods are critical factors in successful GaAs MMIC performance and reliability.

MMA-212734D-M5

21-27GHz, 3W Power Amplifier

Package Pin-out:

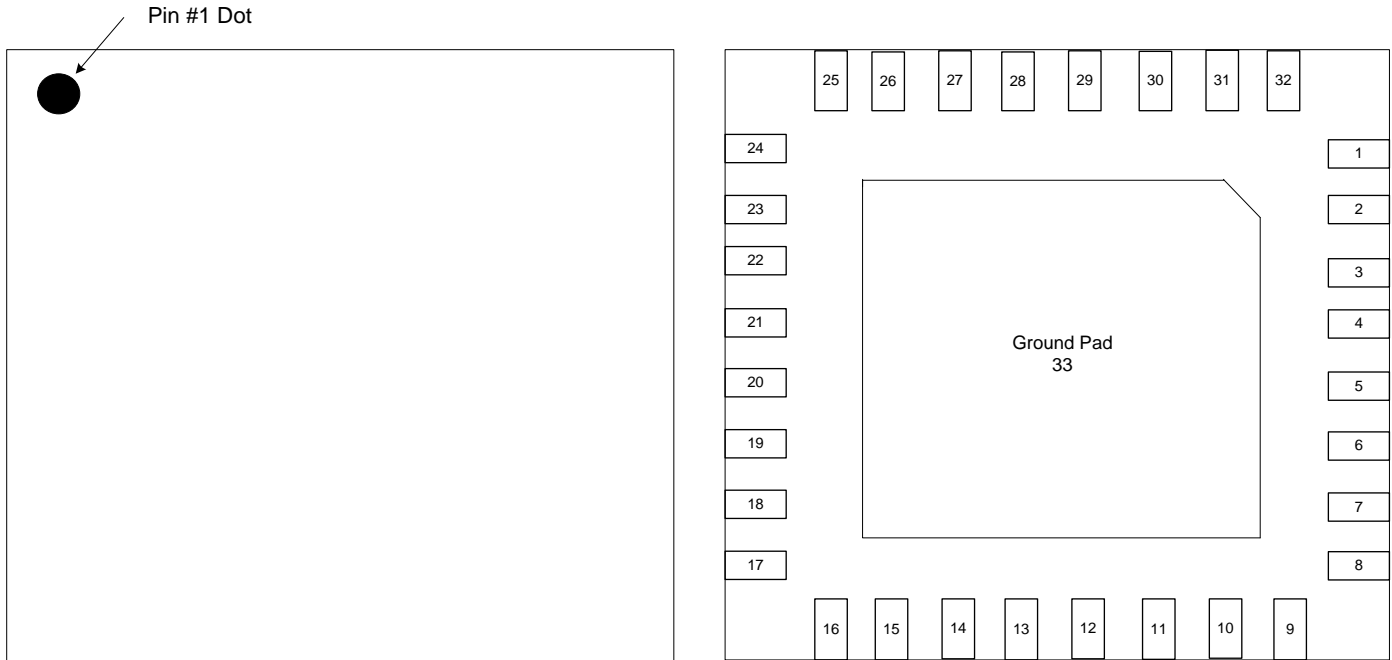

Pin	Description
4	RF Input
21	RF Output
10	Vg
31	Vd1
29	Vd2
28	Vd3
15, 26	Vd4
18	DET_Reference
23	DET_Output
1, 3, 5, 8, 9, 16, 17, 20, 22, 24, 25, 32, 33	Ground
2, 6, 7, 11, 12, 13, 14, 19, 27, 30	N/C

MMA-212734D-M5

21-27GHz, 3W Power Amplifier

Mechanical Information:

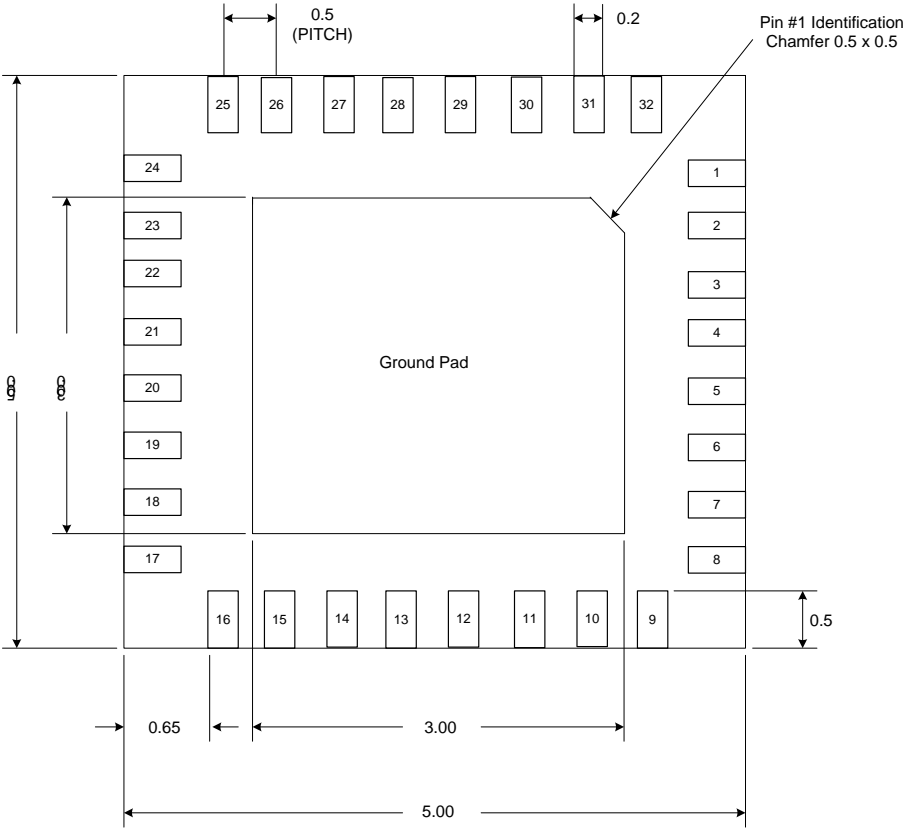

BOTTOM VIEW

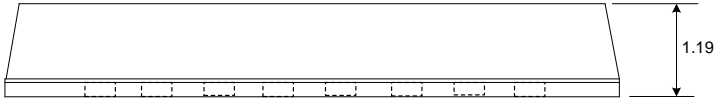

SIDE VIEW

The units are in [mm].

MMA-212734D-M5

21-27GHz, 3W Power Amplifier

Application Circuit:

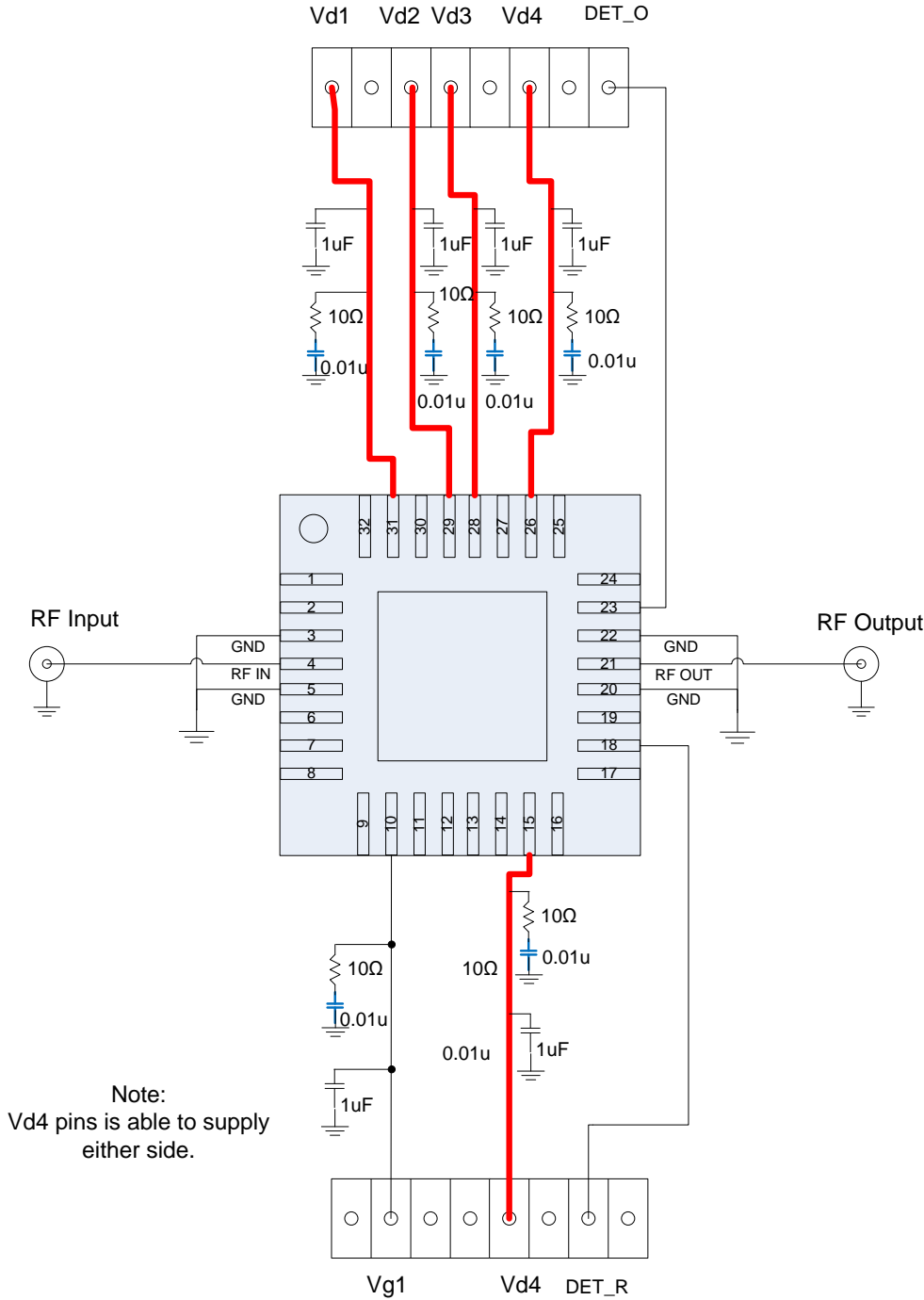

MMA-212734D-M5

21-27GHz, 3W Power Amplifier

Recommended Application Board Design:

Board Material is 10mil (Dielectric) thickness Rogers 4350B with 0.5oz copper clads.

Board is soldered on a gold plated solid copper block and adequate heat-sinking is required for 16.8W total power dissipation.

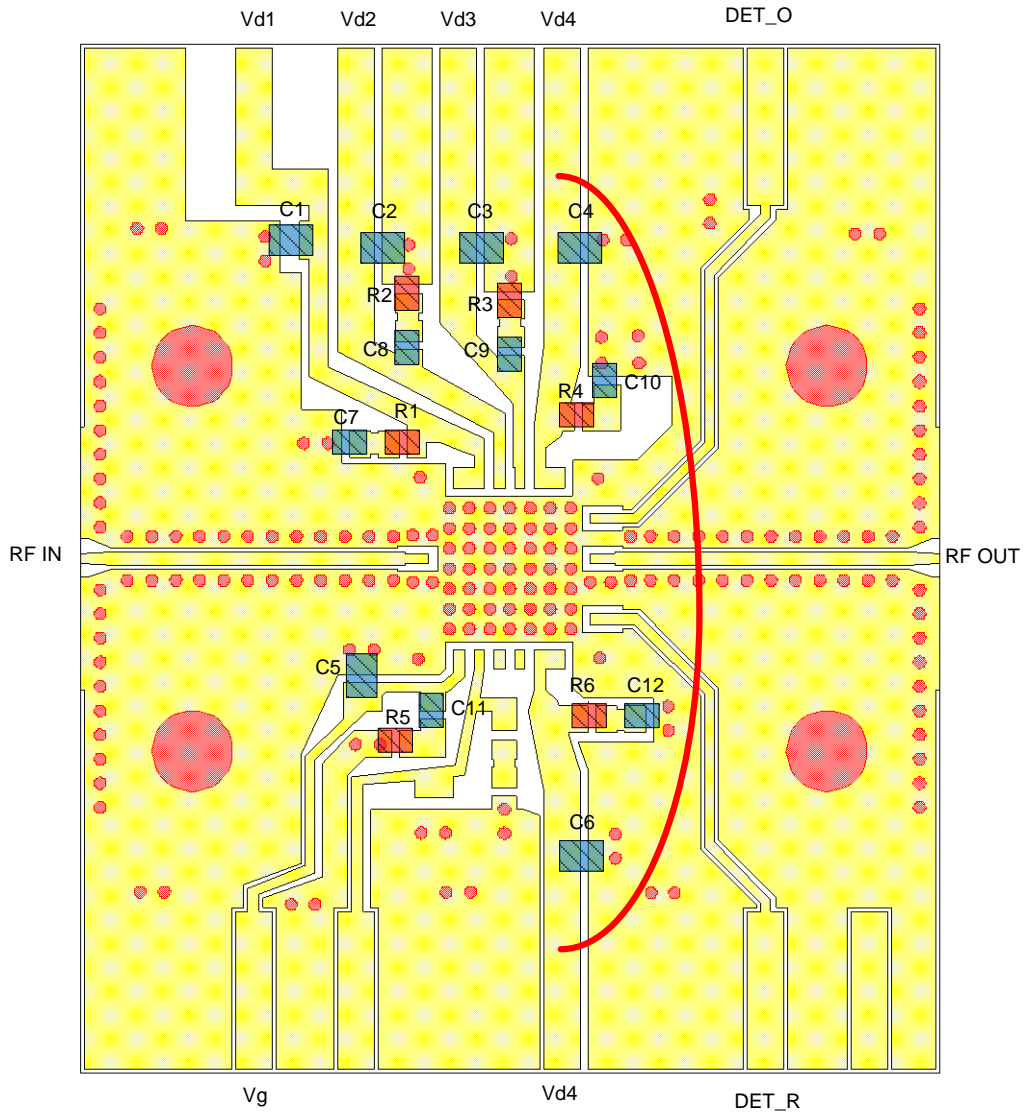

Part	Description
C1, C2, C3, C4, C5, C6	1uF capacitor (0603)
C7, C8, C9, C10, C11, C12	0.01uF Capacitor (0402)
R1, R2, R3, R4, R5, R6	10Ω Resistor (0402)

MMA-212734D-M5

21-27GHz, 3W Power Amplifier

Recommended Application Board Design:

Board Material is 10mil (Dielectric) thickness Rogers 4350B with 0.5oz copper clads. The board material and mounting pattern, as defined in the data sheet, optimizes RF performance and is strongly recommended.

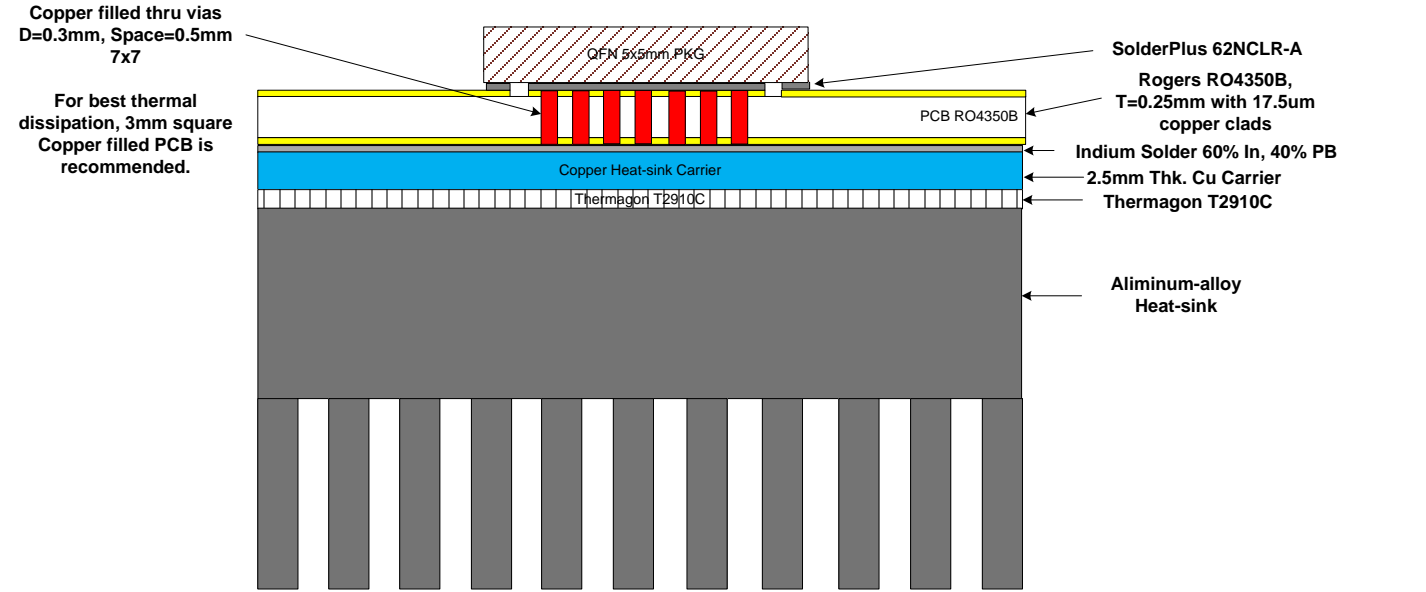
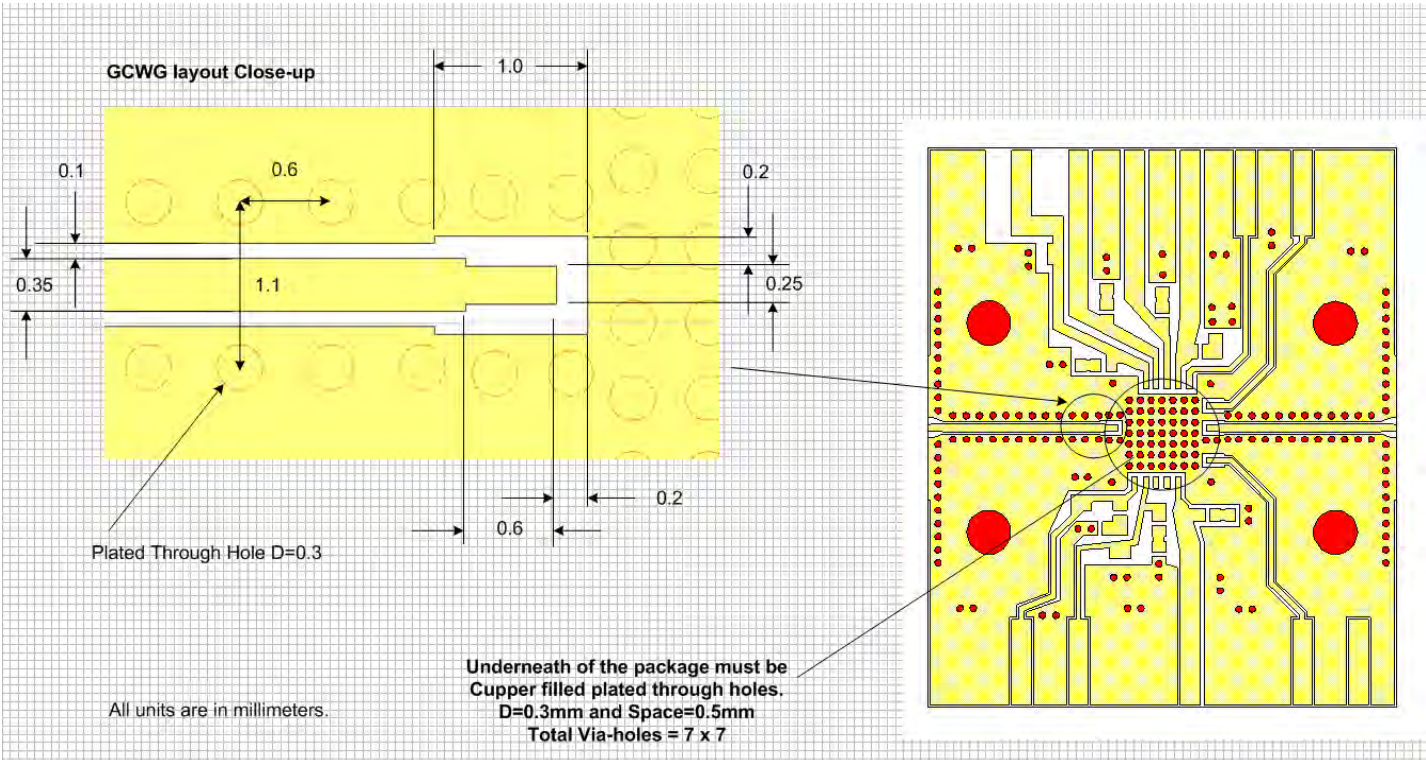

MMA-212734D-M5

21-27GHz, 3W Power Amplifier

Contact Information

For additional information please visit www.cmlmicro.com or contact a sales office.



Europe	America	Asia
<ul style="list-style-type: none">• Maldon, UK• Tel +44 (0) 1621 875500• sales@cmlmicro.com	<ul style="list-style-type: none">• Winston-Salem, NC• Tel +1 336 744 5050• us.sales@cmlmicro.com	<ul style="list-style-type: none">• Singapore• Tel +65 6288129• sg.sales@cmlmicro.com

Although the information contained in this document is believed to be accurate, no responsibility is assumed by CML for its use. The product and product information is subject to change at any time without notice. CML has a policy of testing every product shipped using calibrated test equipment to ensure compliance with product specification.

© 2019 CML Microsystems Plc

Looking for pricing, stock, or lifecycle information?

Click below to explore more details on WIN SOURCE:

-  [View MMA-212734D-M5 on WIN SOURCE](#)
-  [CML Microcircuits Information](#)

Optimize Your Supply Chain with WIN SOURCE Solutions

-  Global Sourcing Solution
-  Obsolete Management
-  Cost Control Management
-  Shortage Management
-  Alternative Solution
-  Excess Inventory Management