

6 mm Square Dustproof Ceramic Trimmer Potentiometers (Cermet, Radial Taping)

Type: **EVMAAS/EVMAES (Radial Taping)**
EVMAAG/EVMAEG/EVMAHG/EVMAJG/EVMASG (Bulk)

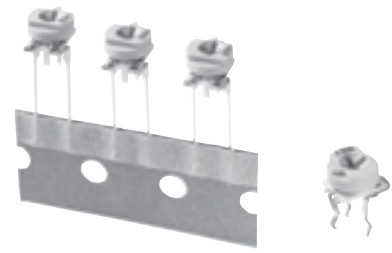

Features

- High reliability due to cermet element
- Excellent automatic insertion due to strong lead terminals
- Available for automatic adjustment due to slot & taper shape suitable for screwdriver
- Dustproof type with electrically activated wiper enclosed in an insulated rotor cap
- Conforms to JIS C5260-1:1999
- RoHS compliant

Recommended Applications

- Audio/visual, office, and communication equipment
- General electronic equipment

Explanation of Part Numbers

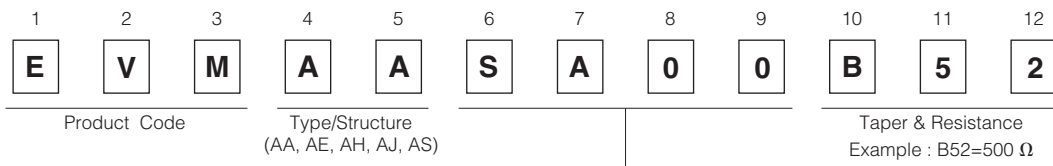

Symbol	Packaging
SA00	Radial taping height 20 mm
SA01	Radial taping height 21 mm
GA00	Bulk Standard

Specifications

	EVMAA□/EVMAHG/EVMAJG/EVMASG	EVMAE□ (Low Resistor Value)
Total Resistance Value	100 Ω to 1 MΩ	10 Ω to 500 Ω
Resistance Tolerance	±25 %	
Power Rating	0.3 W	0.5 W
Limiting Element Voltage	100 V	$\sqrt{P \cdot R}$
Rotation Torque	2 to 30 mN·m	
Stopper Strength	50 mN·m min.	
Temperature Coefficient of Resistance	±200 × 10 ⁻⁶ /°C	· 10 Ω ≤ R ≤ 20 Ω ±200 × 10 ⁻⁶ /°C · 20 Ω < R ≤ 200 Ω ±150 × 10 ⁻⁶ /°C · 200 Ω < R ≤ 500 Ω ±100 × 10 ⁻⁶ /°C

Minimum Quantity/Packing Unit

Part Number	Radial taping		Bulk	
	Quantity per Box	Packaging quantity	Quantity per pack	Packaging quantity
EVMAAS EVMAES	1,000	10,000	—	—
EVMAAG EVMAHG EVMAJG EVMASG	—	—	200	2,000
EVMAEG	—	—	600	3,000

Dimensions in mm (not to scale)

- Radial tapering

- 3-terminal, Top-adjust, Cross Slots EVMAAS/EVMAES

No. 1

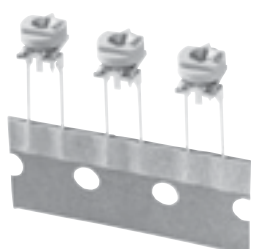
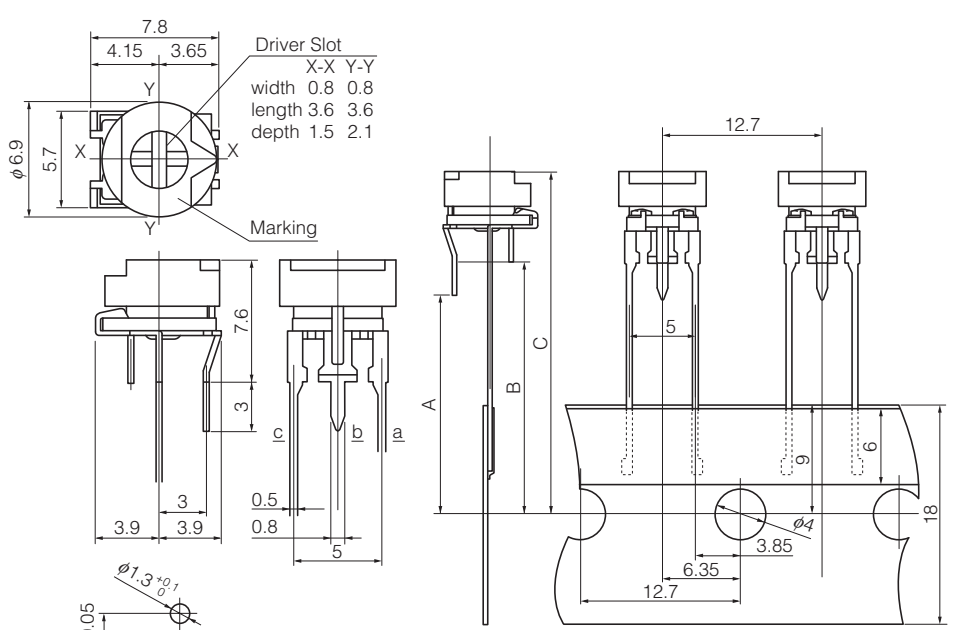
Driver Slot
X-X Y-Y
width 0.8 0.8
length 3.6 3.6
depth 1.5 2.1

Marking

(Recommended PWB Piercing Plan)

(Circuit diagram)

	A	B	C
A00	17	20	27.6
A01	18	21	28.6

Mass (Weight) : 420 mg/pc.

- Bulk

- 3-terminal, Top-adjust, Cross Slots EVMAAG/EVMAEG

No. 2

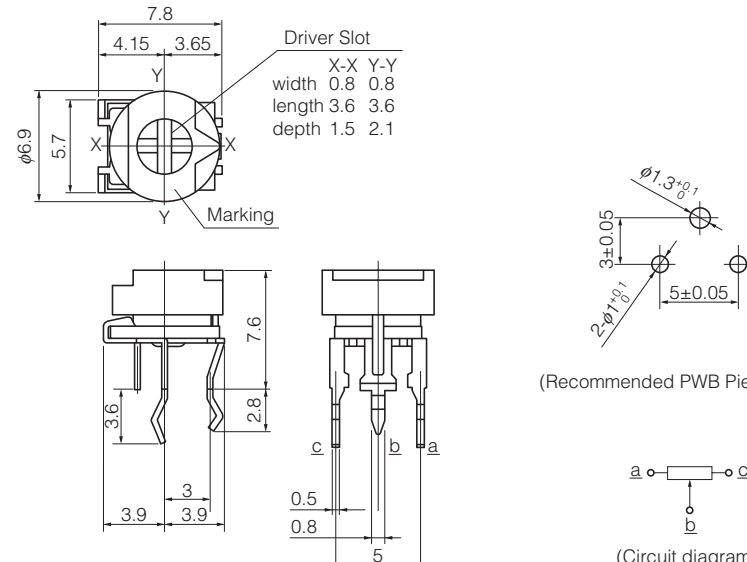
Driver Slot
X-X Y-Y
width 0.8 0.8
length 3.6 3.6
depth 1.5 2.1

Marking

(Recommended PWB Piercing Plan)

(Circuit diagram)

Mass (Weight) : 420 mg/pc.

Dimensions in mm (not to scale)

- Bulk

- 3-terminal, Top-adjust, Cross Slots EVMAHG

No. 3

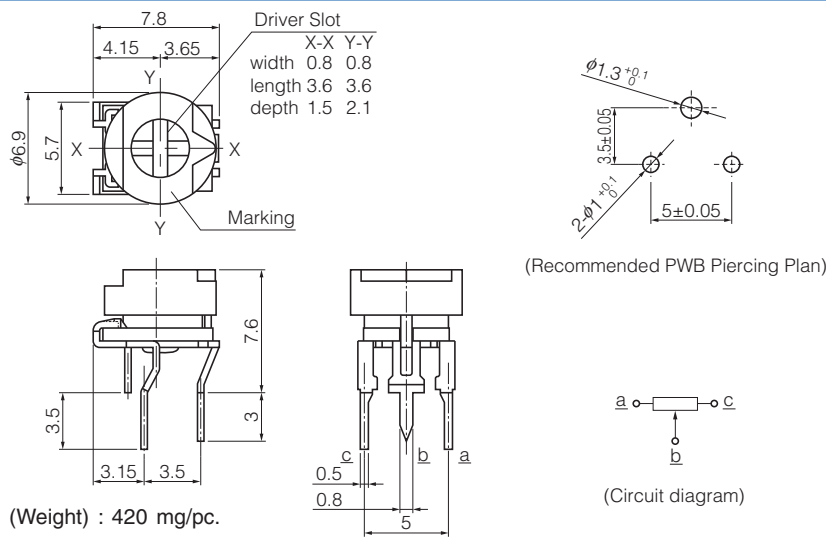
Driver Slot
 X-X Y-Y
 width 0.8 0.8
 length 3.6 3.6
 depth 1.5 2.1

Marking

(Recommended PWB Piercing Plan)

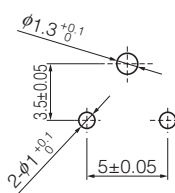

(Circuit diagram)

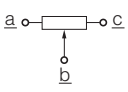

Mass (Weight) : 420 mg/pc.

- 3-terminal, Top-adjust, Cross Slots EVMAJG

No. 4

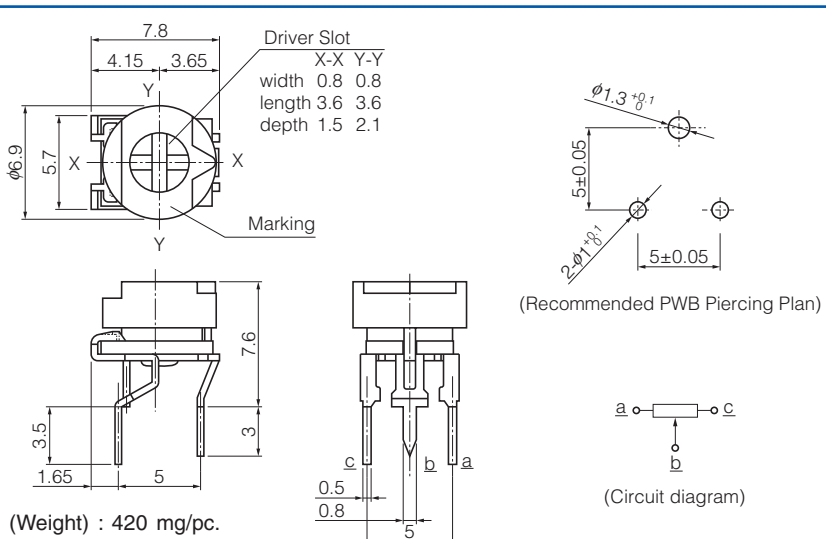
Driver Slot
 X-X Y-Y
 width 0.8 0.8
 length 3.6 3.6
 depth 1.5 2.1

Marking

(Recommended PWB Piercing Plan)

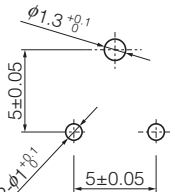

(Circuit diagram)

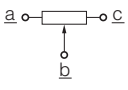

Mass (Weight) : 420 mg/pc.

- 3-terminal, Top-adjust, Cross Slots EVMASG

No. 5

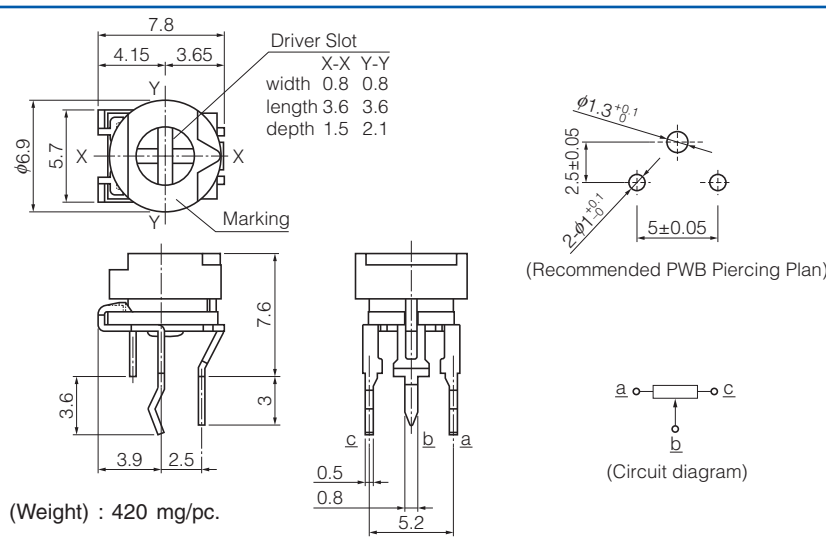
Driver Slot
 X-X Y-Y
 width 0.8 0.8
 length 3.6 3.6
 depth 1.5 2.1

Marking

(Recommended PWB Piercing Plan)

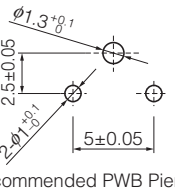

(Circuit diagram)

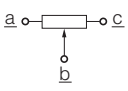

Mass (Weight) : 420 mg/pc.

Looking for pricing, stock, or lifecycle information?

Click below to explore more details on WIN SOURCE:

- ⊖ [View EVMAASA00B52](#) on WIN SOURCE
- ⊖ [Panasonic](#) Information

Optimize Your Supply Chain with WIN SOURCE Solutions

- ✓ Global Sourcing Solution
- ✓ Obsolete Management
- ✓ Cost Control Management
- ✓ Shortage Management
- ✓ Alternative Solution
- ✓ Excess Inventory Management