

RF LDMOS Wideband Integrated Power Amplifiers

The MD8IC970N wideband integrated circuit is designed with on-chip prematching that makes it usable from 136 to 940 MHz. This multi-stage structure is rated for 26 to 32 Volt operation and covers all typical base station modulation formats. This device has a 2-stage design with off-chip matching for the input, interstage and output networks to cover the desired frequency sub-band.

- Typical Two-Tone Performance: $V_{DD1} = 28$ Volts, $V_{DD2} = 25$ Volts, $I_{DQ1(A+B)} = 60$ mA, $I_{DQ2(A+B)} = 550$ mA, $P_{out} = 35$ Watts Avg.

Frequency	G _{ps} (dB)	PAE (%)	IMD (dBc)
850 MHz	30.6	40.1	-30.5
900 MHz	31.9	42.4	-31.0
940 MHz	32.6	42.1	-31.3

- Capable of Handling 10:1 VSWR, @ 32 Vdc, 940 MHz, 137 Watts CW Output Power (3 dB Input Overdrive from Rated P_{out}), Designed for Enhanced Ruggedness
- Typical P_{out} @ 1 dB Compression Point \approx 79 Watts CW

Features

- Characterized with Series Equivalent Large-Signal Impedance Parameters and Common Source S-Parameters
- On-Chip Prematching. On-Chip Stabilization.
- Integrated Quiescent Current Temperature Compensation with Enable/Disable Function (1)
- Integrated ESD Protection
- 225°C Capable Plastic Package
- RoHS Compliant
- In Tape and Reel. R1 Suffix = 500 Units, 44 mm Tape Width, 13 inch Reel.

MD8IC970NR1
MD8IC970GNR1

850-940 MHz, 35 W AVG., 28 V
RF LDMOS WIDEBAND
INTEGRATED POWER AMPLIFIERS

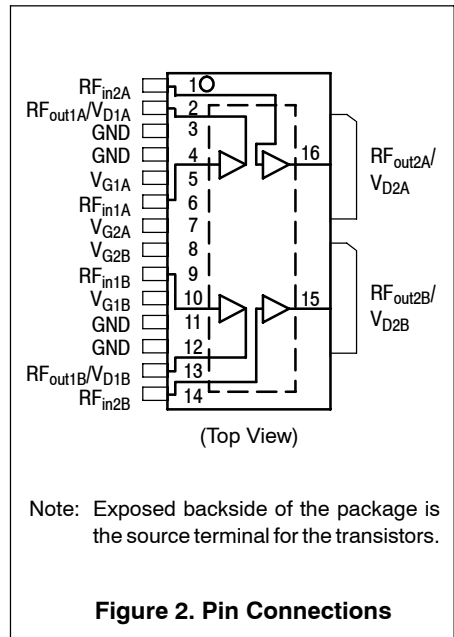
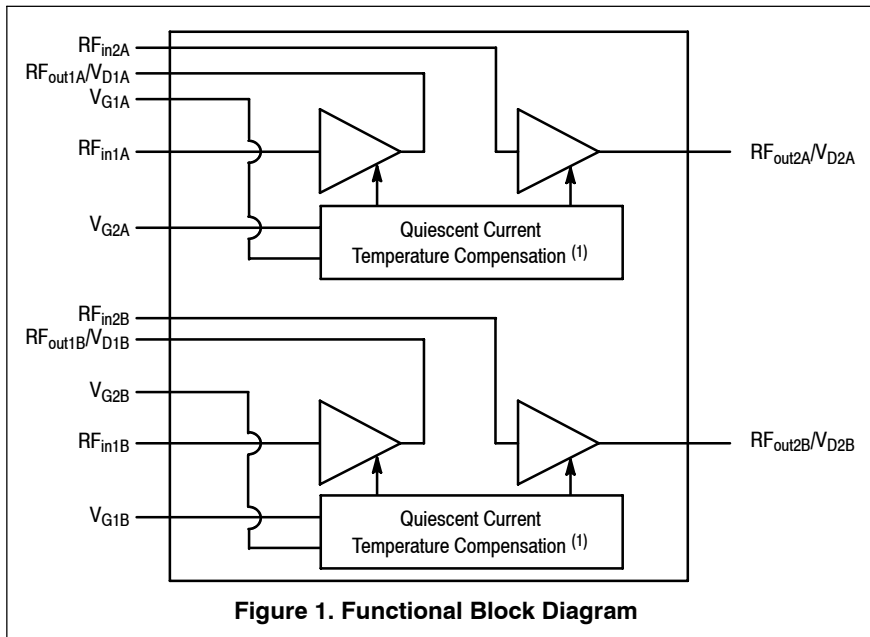
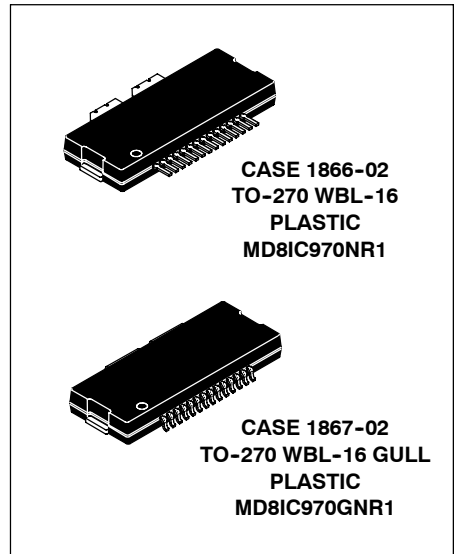

Note: Exposed backside of the package is the source terminal for the transistors.

1. Refer to AN1977, *Quiescent Current Thermal Tracking Circuit in the RF Integrated Circuit Family* and to AN1987, *Quiescent Current Control for the RF Integrated Circuit Device Family*. Go to <http://www.freescale.com/rf>. Select Documentation/Application Notes - AN1977 or AN1987.

Table 1. Maximum Ratings

Rating	Symbol	Value	Unit
Drain-Source Voltage	V_{DSS}	-0.5, +70	Vdc
Gate-Source Voltage	V_{GS}	-0.5, +10	Vdc
Operating Voltage	V_{DD}	32, +0	Vdc
Storage Temperature Range	T_{stg}	-65 to +150	°C
Case Operating Temperature	T_C	150	°C
Operating Junction Temperature (1,2)	T_J	225	°C
Input Power	P_{in}	30	dBm

Table 2. Thermal Characteristics

Characteristic	Symbol	Value (2,3)	Unit
----------------	--------	-------------	------

Final Application

Thermal Resistance, Junction to Case Case Temperature 80°C, 35 W Avg. Two-Tone Stage 1, 28 Vdc, $I_{DQ1(A+B)} = 60$ mA, $f_1 = 939.9$ MHz, $f_2 = 940.1$ MHz Stage 2, 25 Vdc, $I_{DQ2(A+B)} = 550$ mA, $f_1 = 939.9$ MHz, $f_2 = 940.1$ MHz	$R_{\theta JC}$	2.9 0.6	°C/W
--	-----------------	------------	------

Table 3. ESD Protection Characteristics

Test Methodology	Class
Human Body Model (per JESD22-A114)	1A (Minimum)
Machine Model (per EIA/JESD22-A115)	A (Minimum)
Charge Device Model (per JESD22-C101)	I (Minimum)

Table 4. Moisture Sensitivity Level

Test Methodology	Rating	Package Peak Temperature	Unit
Per JESD22-A113, IPC/JEDEC J-STD-020	3	260	°C

Table 5. Electrical Characteristics ($T_A = 25^\circ\text{C}$ unless otherwise noted)

Characteristic	Symbol	Min	Typ	Max	Unit
----------------	--------	-----	-----	-----	------

Stage 1 — Off Characteristics (4)

Zero Gate Voltage Drain Leakage Current ($V_{DS} = 70$ Vdc, $V_{GS} = 0$ Vdc)	I_{DSS}	—	—	10	μAdc
Zero Gate Voltage Drain Leakage Current ($V_{DS} = 28$ Vdc, $V_{GS} = 0$ Vdc)	I_{DSS}	—	—	1	μAdc
Gate-Source Leakage Current ($V_{GS} = 1.5$ Vdc, $V_{DS} = 0$ Vdc)	I_{GSS}	—	—	1	μAdc

Stage 1 — On Characteristics (4)

Gate Threshold Voltage ($V_{DS} = 10$ Vdc, $I_D = 40$ μAdc)	$V_{GS(th)}$	1.2	2.0	2.7	Vdc
Gate Quiescent Voltage ($V_{DS} = 28$ Vdc, $I_{DQ1(A+B)} = 60$ mAdc)	$V_{GS(Q)}$	—	3.1	—	Vdc
Fixture Gate Quiescent Voltage ($V_{DD1} = 28$ Vdc, $I_{DQ1(A+B)} = 60$ mAdc, Measured in Functional Test)	$V_{GG(Q)}$	9.0	10.0	11.0	Vdc

1. Continuous use at maximum temperature will affect MTTF.
2. MTTF calculator available at <http://www.freescale.com/rf>. Select Software & Tools/Development Tools/Calculators to access MTTF calculators by product.
3. Refer to AN1955, *Thermal Measurement Methodology of RF Power Amplifiers*. Go to <http://www.freescale.com/rf>. Select Documentation/Application Notes - AN1955.
4. Side A and Side B are tied together for this measurement.

(continued)

Table 5. Electrical Characteristics ($T_A = 25^\circ\text{C}$ unless otherwise noted) (continued)

Characteristic	Symbol	Min	Typ	Max	Unit
Stage 2 — Off Characteristics (1)					
Zero Gate Voltage Drain Leakage Current ($V_{DS} = 70\text{ Vdc}$, $V_{GS} = 0\text{ Vdc}$)	I_{DSS}	—	—	10	μAdc
Zero Gate Voltage Drain Leakage Current ($V_{DS} = 28\text{ Vdc}$, $V_{GS} = 0\text{ Vdc}$)	I_{DSS}	—	—	1	μAdc
Gate-Source Leakage Current ($V_{GS} = 1.5\text{ Vdc}$, $V_{DS} = 0\text{ Vdc}$)	I_{GSS}	—	—	1	μAdc

Stage 2 — On Characteristics (1)

Gate Threshold Voltage ($V_{DS} = 10\text{ Vdc}$, $I_D = 320\ \mu\text{Adc}$)	$V_{GS(th)}$	1.2	2.0	2.7	Vdc
Gate Quiescent Voltage ($V_{DS} = 25\text{ Vdc}$, $I_{DQ2(A+B)} = 550\text{ mAdc}$)	$V_{GS(Q)}$	—	3.1	—	Vdc
Fixture Gate Quiescent Voltage ($V_{DD2} = 25\text{ Vdc}$, $I_{DQ2(A+B)} = 550\text{ mAdc}$, Measured in Functional Test)	$V_{GG(Q)}$	7.6	8.6	9.6	Vdc
Drain-Source On-Voltage ($V_{GS} = 10\text{ Vdc}$, $I_D = 3.2\text{ Adc}$)	$V_{DS(on)}$	0.1	0.48	1.2	Vdc

Functional Tests (1,2) (In Freescale Test Fixture, 50 ohm system) $V_{DD1} = 28\text{ Vdc}$, $V_{DD2} = 25\text{ Vdc}$, $P_{out} = 35\text{ W Avg.}$, $I_{DQ1(A+B)} = 60\text{ mA}$, $I_{DQ2(A+B)} = 550\text{ mA}$, $f_1 = 939.9\text{ MHz}$, $f_2 = 940.1\text{ MHz}$

Power Gain	G_{ps}	31.5	32.6	36.5	dB
Power Added Efficiency	PAE	40.5	42.1	—	%
Intermodulation Distortion	IMD	—	-31.3	-29.0	dB

Typical Broadband Performance (1) (In Freescale Test Fixture, 50 ohm system) $V_{DD1} = 28\text{ Vdc}$, $V_{DD2} = 25\text{ Vdc}$, $P_{out} = 35\text{ W Avg.}$, $I_{DQ1(A+B)} = 60\text{ mA}$, $I_{DQ2(A+B)} = 550\text{ mA}$

Frequency	G_{ps} (dB)	PAE (%)	IMD (dBc)
850 MHz	30.6	40.1	-30.5
900 MHz	31.9	42.4	-31.0
940 MHz	32.6	42.1	-31.3

Typical Performances (1) (In Freescale Test Fixture, 50 ohm system) $V_{DD1} = 28\text{ Vdc}$, $V_{DD2} = 25\text{ Vdc}$, $I_{DQ1(A+B)} = 60\text{ mA}$, $I_{DQ2(A+B)} = 550\text{ mA}$, 850-940 MHz Bandwidth

Characteristic	Symbol	Min	Typ	Max	Unit
P_{out} @ 1 dB Compression Point, CW	P_{1dB}	—	79	—	W
IMD Symmetry @ 71 W PEP, P_{out} where IMD Third Order Intermodulation $\cong 30\text{ dBc}$ (Delta IMD Third Order Intermodulation between Upper and Lower Sidebands > 2 dB)	IMD_{sym}	—	22	—	MHz
VBW Resonance Point (IMD Third Order Intermodulation Inflection Point)	VBW_{res}	—	50	—	MHz
Quiescent Current Accuracy over Temperature with 8.25 k Ω Gate Feed Resistors (-30 to 85°C) (3)	ΔI_{QT}	—	5.03 4.61	—	%
Gain Flatness in 90 MHz Bandwidth @ $P_{out} = 35\text{ W Avg.}$	G_F	—	1.2	—	dB
Gain Variation over Temperature (-30°C to +85°C)	ΔG	—	0.03	—	dB/°C
Output Power Variation over Temperature (-30°C to +85°C)	ΔP_{1dB}	—	0.005	—	dB/°C

- Side A and Side B are tied together for this measurement.
- Part internally matched both on input and output.
- Refer to AN1977, *Quiescent Current Thermal Tracking Circuit in the RF Integrated Circuit Family* and to AN1987, *Quiescent Current Control for the RF Integrated Circuit Device Family*. Go to <http://www.freescale.com/rf>. Select Documentation/Application Notes - AN1977 or AN1987.

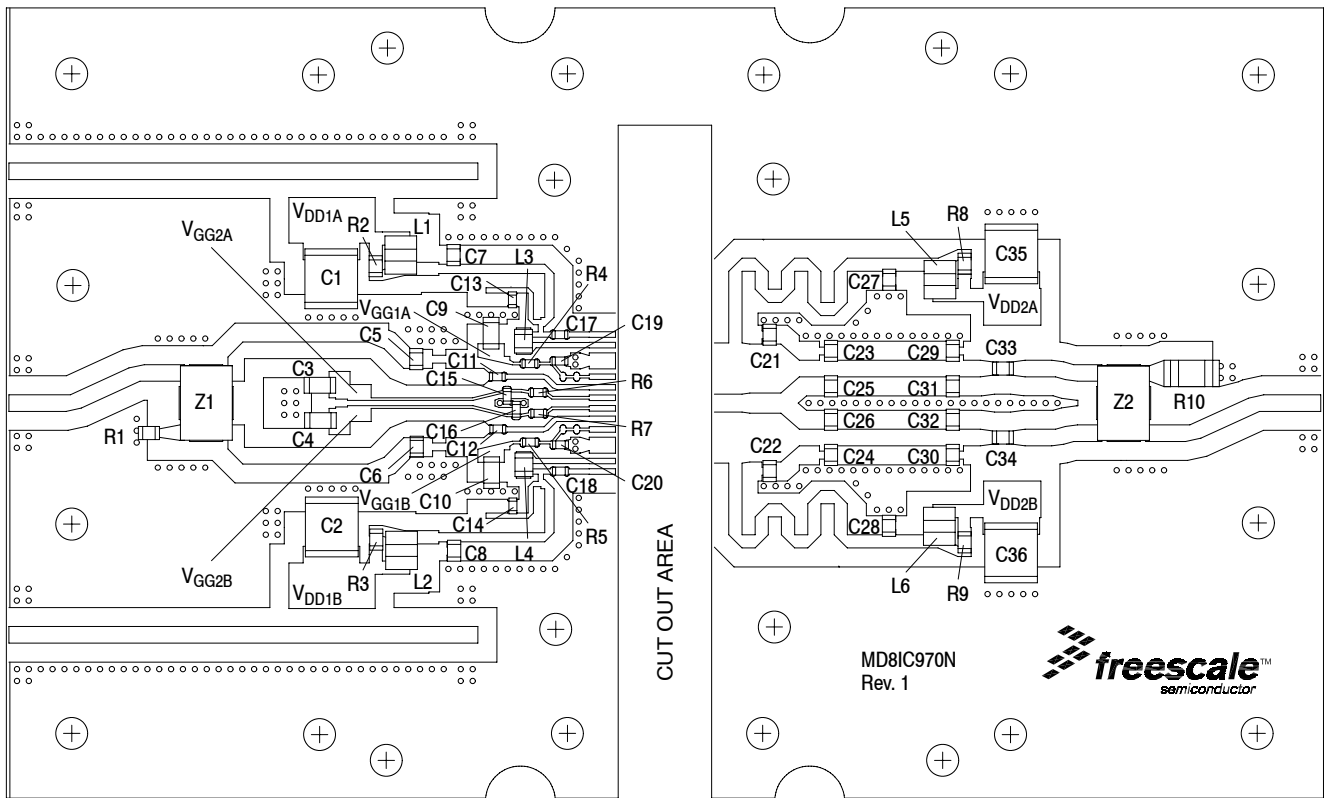

Figure 3. MD8IC970NR1(GNR1) Test Circuit Component Layout

Table 6. MD8IC970NR1(GNR1) Test Circuit Component Designations and Values

Part	Description	Part Number	Manufacturer
C1, C2, C35, C36	10 μ F, 50 V Chip Capacitors	GRM55DR61H106KA88L	Murata
C3, C4, C9, C10	1 μ F, 50 V Chip Capacitors	GRM31MR71H105KA88L	Murata
C5, C6	3.3 pF Chip Capacitors	ATC600F3R3BT250XT	ATC
C7, C8, C27, C28, C33, C34	39 pF Chip Capacitors	ATC600F390JT250XT	ATC
C11, C12	47 pF Chip Capacitors	ATC600S470JT250XT	ATC
C13, C14	4.7 pF Chip Capacitors	ATC600S4R7JT250XT	ATC
C15, C16, C19, C20	0.1 μ F, 50 V Chip Capacitors	GRM188R71C104K01D	Murata
C17, C18	5.6 pF Chip Capacitors	ATC600S5R6JT250XT	ATC
C21, C22	15 pF Chip Capacitors	ATC600F150JT250XT	ATC
C23, C24, C25, C26	4.7 pF Chip Capacitors	ATC600F4R7BT250XT	ATC
C29, C30, C31, C32	2.7 pF Chip Capacitors	ATC600F2R7BT250XT	ATC
L1, L2, L5, L6	5.0 nH 2 Turn Inductors	A02TKLC	Coilcraft
L3, L4	2.8 nH Chip Inductors	0805CS-020XJLC	Coilcraft
R1	51 Ω , 1/8 W Chip Resistor	SG73P2ATTD51R0F	KOA Speer
R2, R3, R8, R9	10 Ω , 1/8 W Chip Resistors	RK73H2ATTD10R0F	KOA Speer
R4, R5, R6, R7	8.25 k Ω , 1/10 W Chip Resistors	RK73H1JTTD8251F	KOA Speer
R10	50 Ω , 10 W SM Chip Power Resistor	81A7031-50-5F	Florida RF Labs
Z1, Z2	900 MHz Band, 90°, 3 dB Chip Hybrid Couplers	GSC362-HYB0900	Soshin
PCB	0.030", $\epsilon_r = 3.66$	RO4350B	Rogers

TYPICAL CHARACTERISTICS

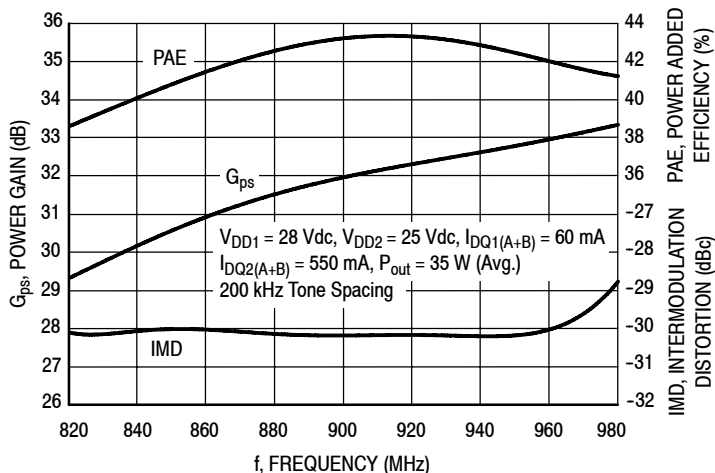

Figure 4. Two-Tone Broadband Performance @ $P_{out} = 35 \text{ Watts Avg.}$

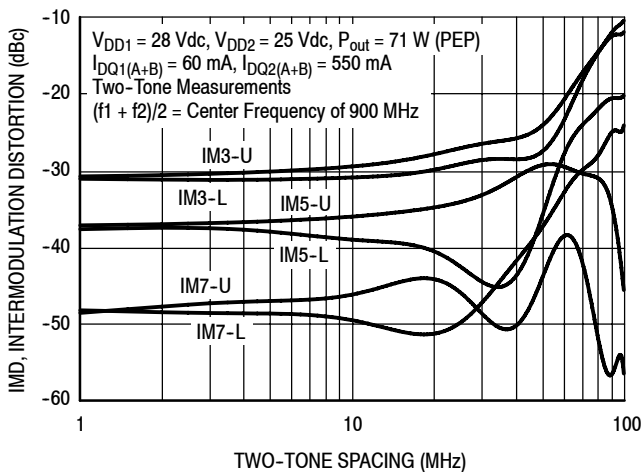

Figure 5. Intermodulation Distortion Products versus Two-Tone Spacing

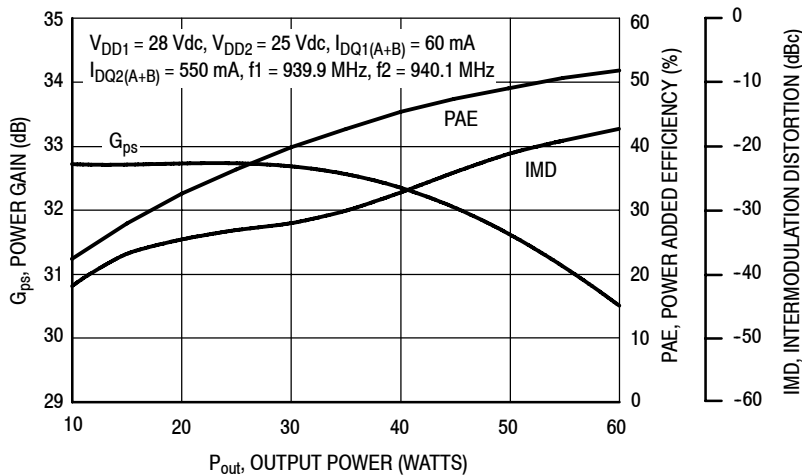

Figure 6. Power Gain, Power Added Efficiency and Intermodulation Distortion Products versus Average Output Power

TYPICAL CHARACTERISTICS

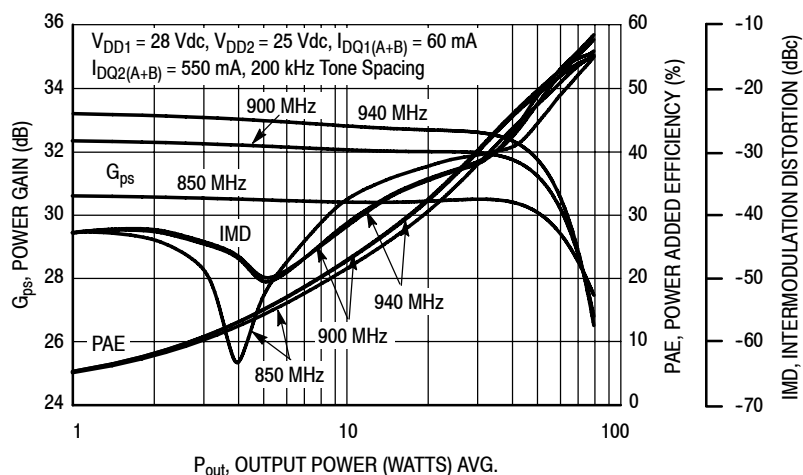

Figure 7. Power Gain, Power Added Efficiency and Intermodulation Distortion Products versus Output Power

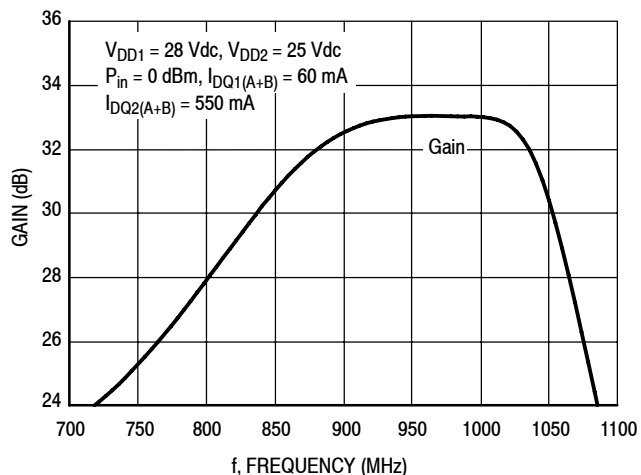

Figure 8. Broadband Frequency Response

$V_{DD1} = 28 \text{ Vdc}$, $I_{DQ1(A)} = 30 \text{ mA}$

f MHz	Z_{in} Ω	Z_{load} Ω
820	18.4 - j13.0	11.3 + j20.0
840	18.8 - j12.7	11.7 + j21.9
860	19.1 - j12.9	12.1 + j23.4
880	19.1 - j13.2	12.5 + j24.5
900	18.7 - j13.6	12.7 + j25.1
920	18.0 - j13.9	12.5 + j25.6
940	17.2 - j14.2	11.8 + j26.0
960	16.1 - j14.3	10.9 + j26.6
980	14.6 - j14.3	9.6 + j27.4

Z_{in} = Device input impedance as measured from gate to ground.

Z_{load} = Test circuit impedance as measured from drain to ground.

f MHz	Z_{in} Ω	Z_{load} Ω
330	31.2 - j21.5	16.2 + j57.8
350	33.6 - j18.7	24.2 + j59.6
370	35.8 - j18.8	29.8 + j55.6
390	36.4 - j19.6	29.0 + j52.8
410	37.0 - j20.1	27.8 + j54.7
430	37.7 - j21.7	30.2 + j58.5
450	36.2 - j24.8	38.8 + j59.1

Z_{in} = Device input impedance as measured from gate to ground.

Z_{load} = Test circuit impedance as measured from drain to ground.

f MHz	Z_{in} Ω	Z_{load} Ω
120	42.7 - j27.4	47.3 + j80.0
130	40.0 - j22.5	61.4 + j93.3
140	40.2 - j16.0	84.0 + j104.2
150	43.8 - j13.3	114.5 + j107.2
160	47.8 - j10.0	147.2 + j98.5
170	51.5 - j10.0	179.4 + j81.3
180	54.9 - j10.6	215.9 + j53.3
190	58.2 - j12.9	256.6 - j7.6
200	59.6 - j16.9	233.3 - j109.9

Z_{in} = Device input impedance as measured from gate to ground.

Z_{load} = Test circuit impedance as measured from drain to ground.

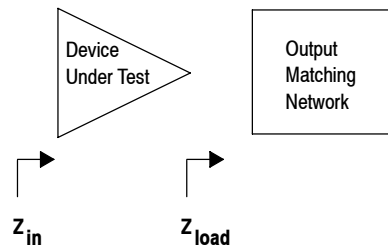

Figure 9. Series Equivalent Input and Load Impedance — Stage 1

NOTE: Measurement made on a per side basis.

$V_{DD2} = 25 \text{ Vdc}$, $I_{DQ2(A)} = 275 \text{ mA}$, $P_{out} = 17.5 \text{ Watts Avg.}$

f MHz	Z_{in} Ω	Z_{load} Ω
820	9.49 + j10.2	3.19 + j1.99
840	10.3 + j10.3	3.29 + j2.11
860	11.2 + j10.2	3.39 + j2.18
880	12.2 + j9.89	3.45 + j2.20
900	13.1 + j9.34	3.46 + j2.16
920	14.0 + j8.53	3.40 + j2.08
940	14.6 + j7.51	3.24 + j2.00
960	15.1 + j6.28	2.98 + j1.96
980	15.2 + j4.87	2.66 + j1.99

Z_{in} = Device input impedance as measured from gate to ground.

Z_{load} = Test circuit impedance as measured from drain to ground.

f MHz	Z_{in} Ω	Z_{load} Ω
330	5.78 + j3.02	5.53 + j1.53
350	5.73 + j3.40	6.27 + j1.77
370	5.66 + j3.89	6.95 + j1.55
390	5.63 + j4.34	7.18 + j0.90
410	5.60 + j4.75	6.67 + j0.22
430	5.53 + j5.06	5.61 + j0.05
450	5.38 + j5.32	4.45 + j0.57

Z_{in} = Device input impedance as measured from gate to ground.

Z_{load} = Test circuit impedance as measured from drain to ground.

f MHz	Z_{in} Ω	Z_{load} Ω
120	5.47 - j0.60	5.74 + j2.70
130	5.46 - j0.36	6.36 + j1.97
140	5.47 - j0.13	6.21 + j1.37
150	5.47 + j0.11	5.95 + j1.37
160	5.46 + j0.35	6.09 + j1.63
170	5.43 + j0.56	6.59 + j1.58
180	5.42 + j0.75	6.70 + j0.92
190	5.49 + j0.93	5.73 + j0.82
200	5.42 + j1.05	4.83 + j2.57

Z_{in} = Device input impedance as measured from gate to ground.

Z_{load} = Test circuit impedance as measured from drain to ground.

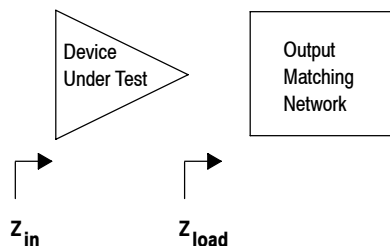

Figure 10. Series Equivalent Input and Load Impedance — Stage 2

NOTE: Measurement made on a per side basis.

ALTERNATIVE PEAK TUNE LOAD PULL CHARACTERISTICS — STAGE 2

$V_{DD2} = 25 \text{ Vdc}$, $I_{DQ2} = 300 \text{ mA}$, CW

f MHz	Z_{source} Ω	$Z_{\text{load}}^{(1)}$ Ω	Max P_{out}	
			P1dB	
			dBm	W
850	$10.9 + j10.2$	$3.34 + j2.16$	47.1	51
940	$14.6 + j7.51$	$3.24 + j2.00$	46.8	48

(1) Load impedance for optimum P1dB power.

Z_{source} = Impedance as measured from gate contact to ground.

Z_{load} = Impedance as measured from drain contact to ground.

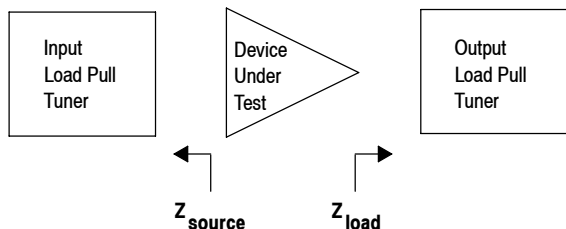

Figure 11. Single Side Load Pull Performance — Maximum P1dB Tuning

$V_{DD2} = 25 \text{ Vdc}$, $I_{DQ2} = 300 \text{ mA}$, CW

f MHz	Z_{source} Ω	$Z_{\text{load}}^{(1)}$ Ω	Max Eff.
			P1dB %
			850
940	$14.6 + j7.51$	$2.95 + j3.66$	62.1

(1) Load impedance for optimum P1dB efficiency.

Z_{source} = Impedance as measured from gate contact to ground.

Z_{load} = Impedance as measured from drain contact to ground.

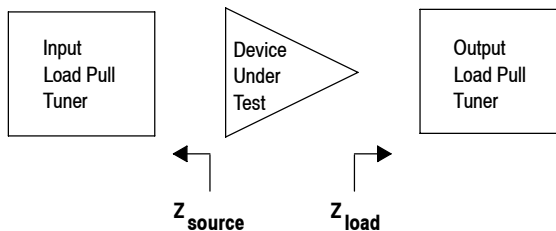

Figure 12. Single Side Load Pull Performance — Maximum Efficiency Tuning

$V_{DD2} = 25 \text{ Vdc}$, $I_{DQ2} = 300 \text{ mA}$, CW

f MHz	Z_{source} Ω	$Z_{\text{load}}^{(1)}$ Ω	Max P_{out}	
			P1dB	
			dBm	W
430	$5.53 + j5.06$	$5.61 + j0.05$	46.8	48

(1) Load impedance for optimum P1dB power.

Z_{source} = Impedance as measured from gate contact to ground.

Z_{load} = Impedance as measured from drain contact to ground.

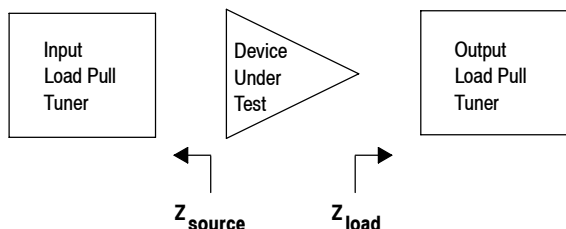

Figure 13. Single Side Load Pull Performance — Maximum P1dB Tuning

$V_{DD2} = 25 \text{ Vdc}$, $I_{DQ2} = 300 \text{ mA}$, CW

f MHz	Z_{source} Ω	$Z_{\text{load}}^{(1)}$ Ω	Max Eff.
			P1dB %
			430

(1) Load impedance for optimum P1dB efficiency.

Z_{source} = Impedance as measured from gate contact to ground.

Z_{load} = Impedance as measured from drain contact to ground.

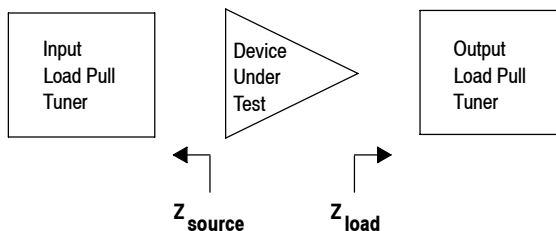
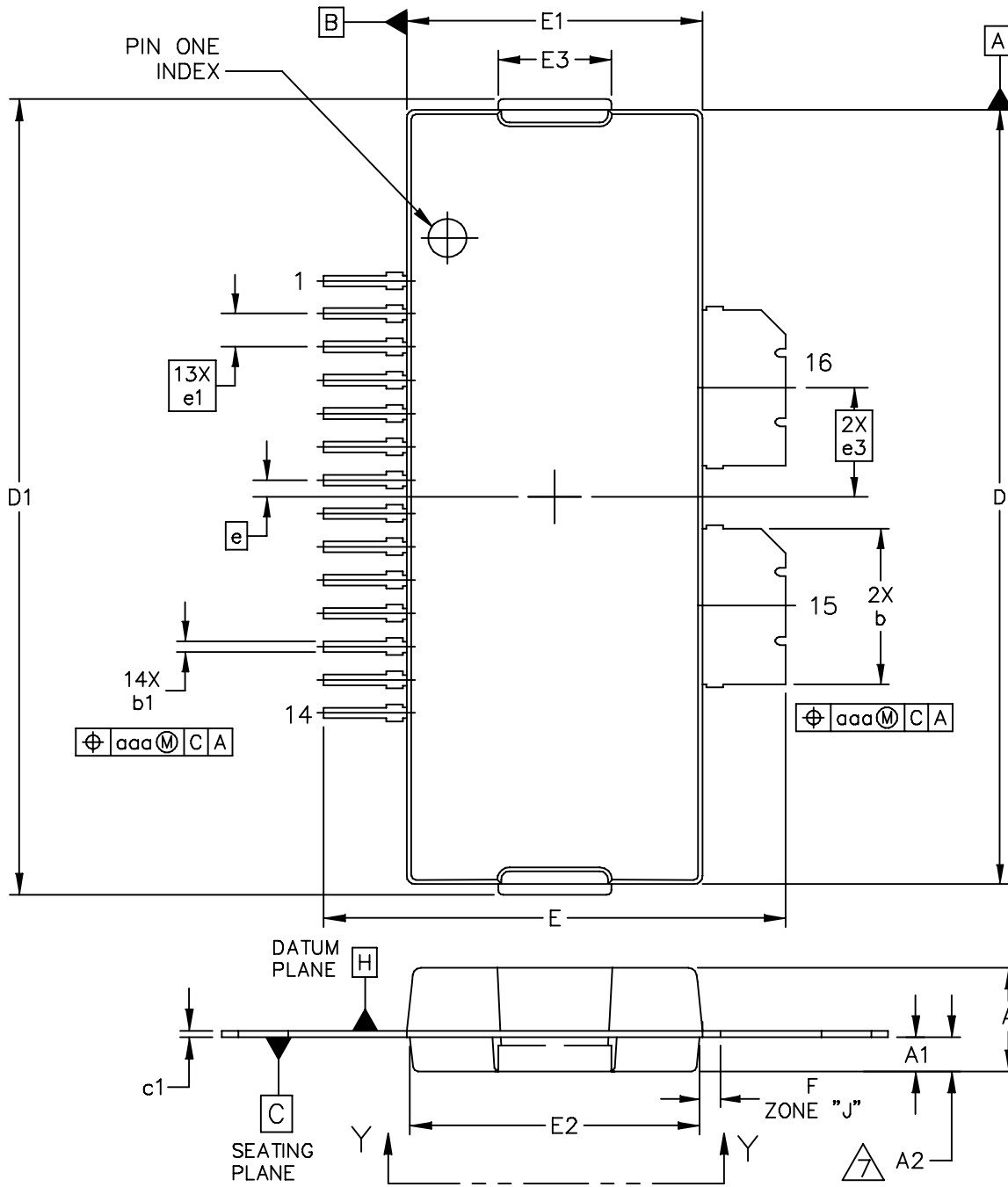
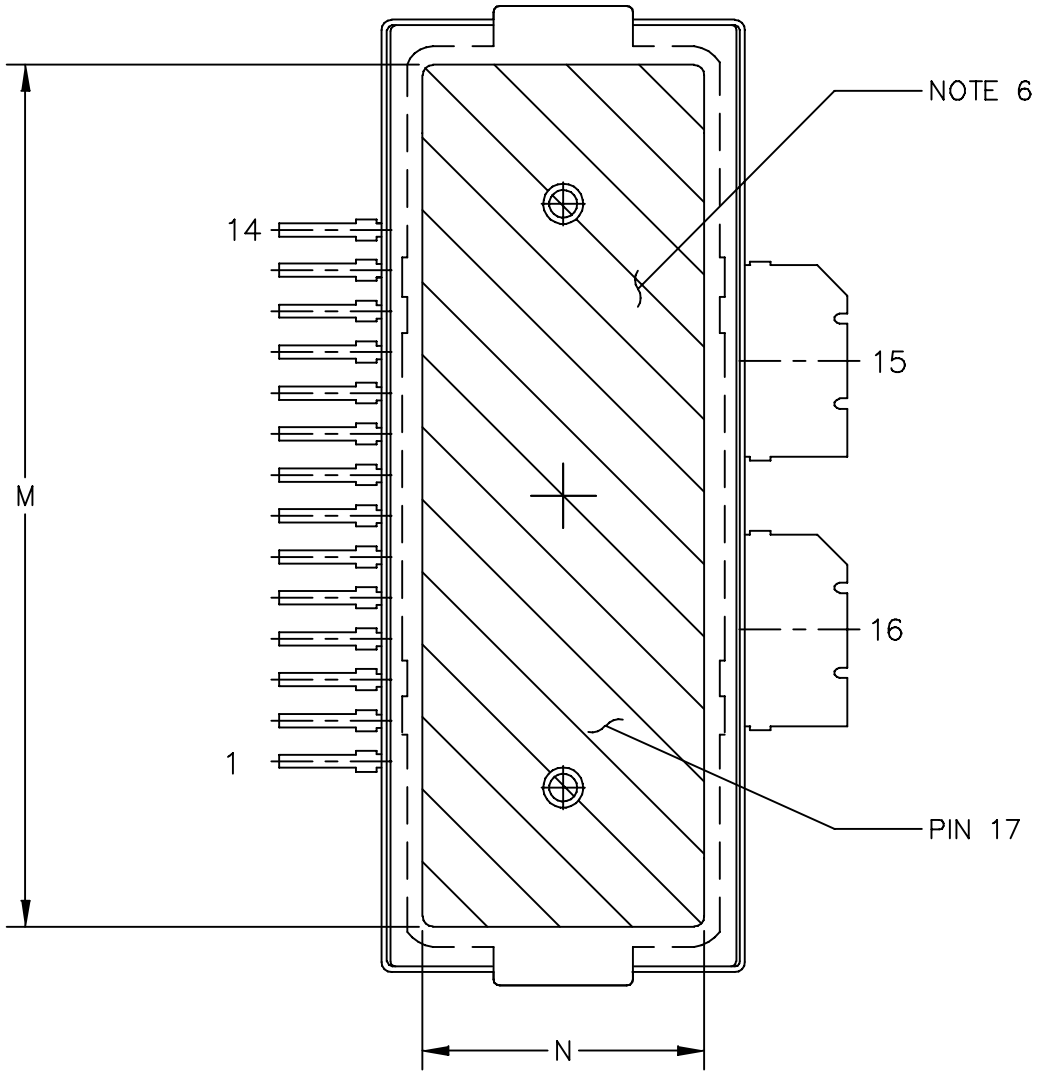

Figure 14. Single Side Load Pull Performance — Maximum Efficiency Tuning

PACKAGE DIMENSIONS



© FREESCALE SEMICONDUCTOR, INC. ALL RIGHTS RESERVED.	MECHANICAL OUTLINE	PRINT VERSION NOT TO SCALE
TITLE: TO-270 WIDE BODY LONG, 16 LEAD, PLASTIC	DOCUMENT NO: 98ASA10739D	REV: A
	CASE NUMBER: 1866-02	02 AUG 2007
	STANDARD: NON-JEDEC	



VIEW Y-Y

© FREESCALE SEMICONDUCTOR, INC. ALL RIGHTS RESERVED.	MECHANICAL OUTLINE	PRINT VERSION NOT TO SCALE	
TITLE: TO-270 WIDE BODY LONG, 16 LEAD, PLASTIC	DOCUMENT NO: 98ASA10739D	REV: A	
	CASE NUMBER: 1866-02	02 AUG 2007	
	STANDARD: NON-JEDEC		

NOTES:

1. CONTROLLING DIMENSION: INCH
2. INTERPRET DIMENSIONS AND TOLERANCES PER ASME Y14.5M-1994.
3. DATUM PLANE -H- IS LOCATED AT THE TOP OF LEAD AND IS COINCIDENT WITH THE LEAD WHERE THE LEAD EXITS THE PLASTIC BODY AT THE TOP OF THE PARTING LINE.
4. DIMENSIONS "D" AND "E1" DO NOT INCLUDE MOLD PROTRUSION. ALLOWABLE PROTRUSION IS .006 (0.15) PER SIDE. DIMENSIONS "D" AND "E1" DO INCLUDE MOLD MISMATCH AND ARE DETERMINED AT DATUM PLANE -H-.
5. DIMENSIONS "b" AND "b1" DO NOT INCLUDE DAMBAR PROTRUSION. ALLOWABLE DAMBAR PROTRUSION SHALL BE .005 (0.13) TOTAL IN EXCESS OF THE "b" AND "b1" DIMENSIONS AT MAXIMUM MATERIAL CONDITION.
6. HATCHING REPRESENTS THE EXPOSED AREA OF THE HEAT SLUG.
7. DIM A2 APPLIES WITHIN ZONE "J" ONLY.

DIM	INCH		MILLIMETER		DIM	INCH		MILLIMETER	
	MIN	MAX	MIN	MAX		MIN	MAX	MIN	MAX
A	.122	.128	3.10	3.25	M	.800	----	20.32	----
A1	.039	.043	0.96	1.12	N	.270	----	6.86	----
A2	.040	.042	1.02	1.07	b	.184	.190	4.67	4.83
D	.928	.932	23.57	23.67	b1	.010	.016	0.25	0.41
D1	.954	.958	24.23	24.33	c1	.007	.011	0.18	0.28
E	.551	.559	14.00	14.20	e	.020 BSC		0.51 BSC	
E1	.353	.357	8.97	9.07	e1	.040 BSC		1.02 BSC	
E2	.346	.350	8.79	8.89	e3	.131 BSC		3.33 BSC	
E3	.132	.140	3.35	3.56					
F	.025 BSC		0.64 BSC		aaa	.004		0.10	
© FREESCALE SEMICONDUCTOR, INC. ALL RIGHTS RESERVED.			MECHANICAL OUTLINE			PRINT VERSION NOT TO SCALE			
TITLE: TO-270 WIDE BODY LONG, 16 LEAD, PLASTIC					DOCUMENT NO: 98ASA10739D			REV: A	
					CASE NUMBER: 1866-02			02 AUG 2007	
					STANDARD: NON-JEDEC				

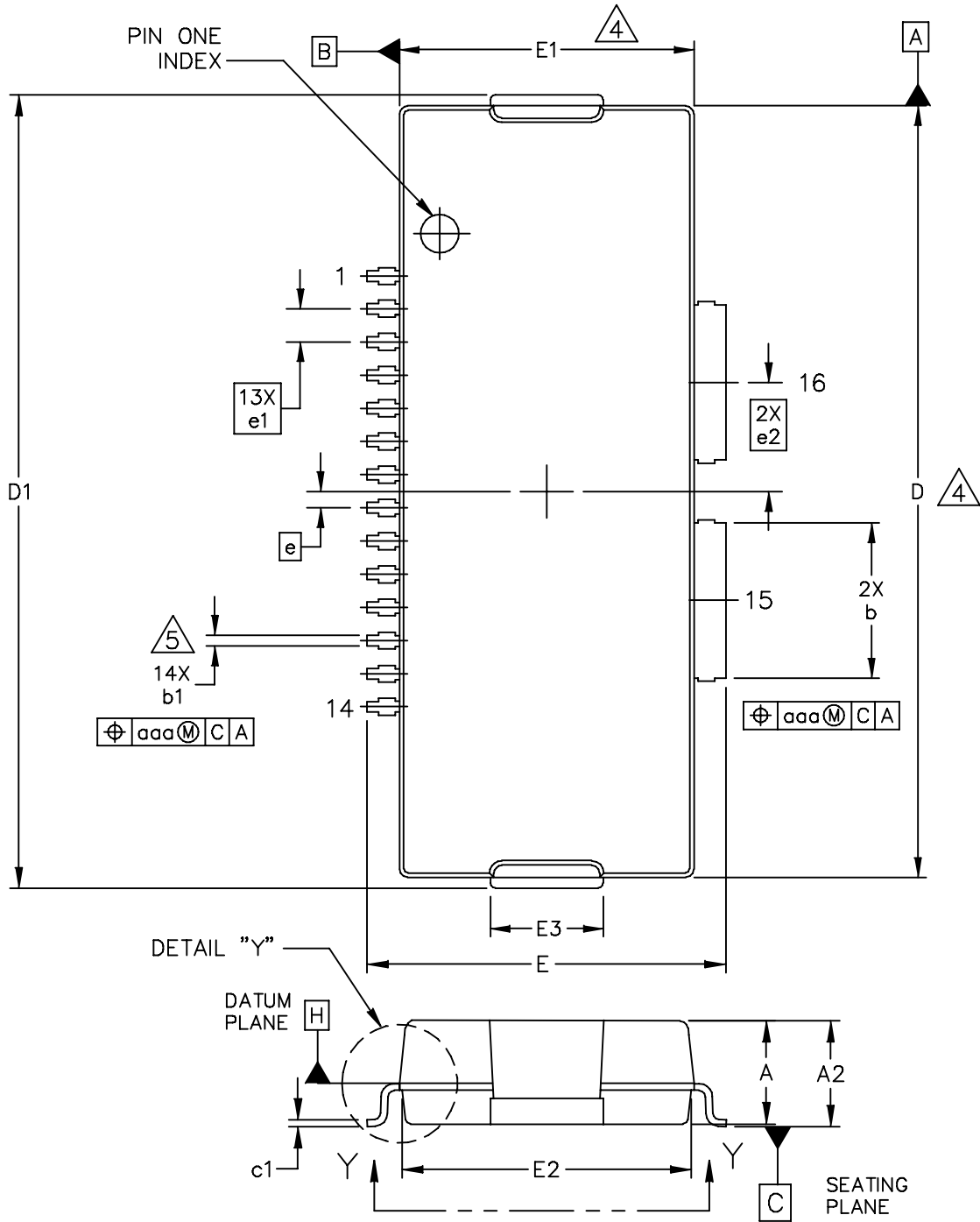

© FREESCALE SEMICONDUCTOR, INC. ALL RIGHTS RESERVED.		MECHANICAL OUTLINE		PRINT VERSION NOT TO SCALE	
TITLE: TO-270 WIDE BODY LONG, 16 LEAD, GULL WING PLASTIC		DOCUMENT NO: 98ASA10740D		REV: C	
		CASE NUMBER: 1867-02		18 MAY 2010	
		STANDARD: NON-JEDEC			

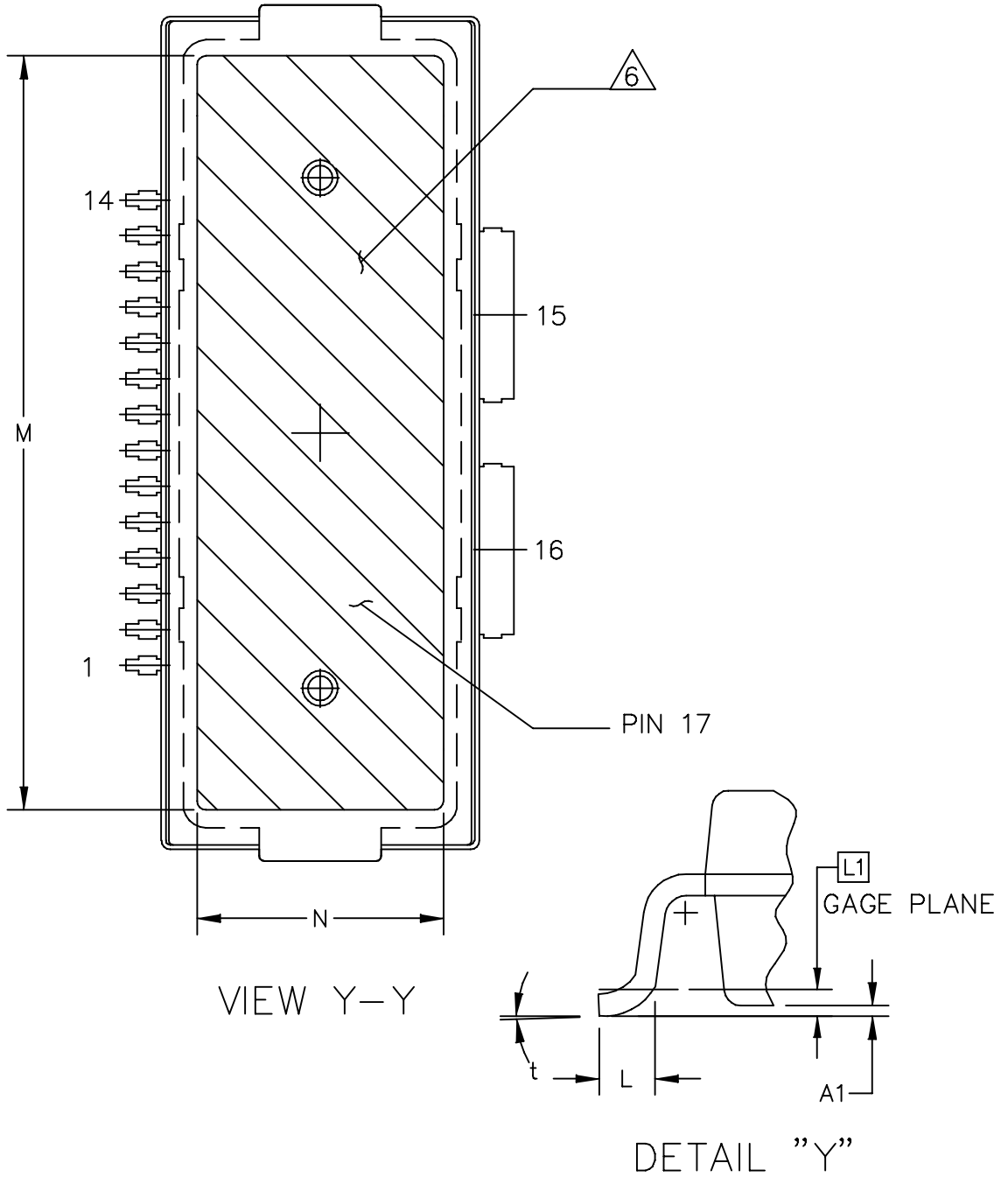

© FREESCALE SEMICONDUCTOR, INC. ALL RIGHTS RESERVED.		MECHANICAL OUTLINE	PRINT VERSION NOT TO SCALE
TITLE: TO-270 WIDE BODY LONG, 16 LEAD, GULL WING PLASTIC		DOCUMENT NO: 98ASA10740D	REV: C
		CASE NUMBER: 1867-02	18 MAY 2010
		STANDARD: NON-JEDEC	

NOTES:

1. CONTROLLING DIMENSION: INCH
 2. INTERPRET DIMENSIONS AND TOLERANCES PER ASME Y14.5M-1994.
 3. DATUM PLANE H IS LOCATED AT THE TOP OF LEAD AND IS COINCIDENT WITH THE LEAD WHERE THE LEAD EXITS THE PLASTIC BODY AT THE TOP OF THE PARTING LINE.
4. DIMENSIONS DO NOT INCLUDE MOLD PROTRUSION. ALLOWABLE PROTRUSION IS .006 PER SIDE. DIMENSIONS DO INCLUDE MOLD MISMATCH AND ARE DETERMINED AT DATUM PLANE H.
5. DIMENSION DOES NOT INCLUDE DAMBAR PROTRUSION. ALLOWABLE DAMBAR PROTRUSION SHALL BE .005 TOTAL IN EXCESS OF THE DIMENSION AT MAXIMUM MATERIAL CONDITION.
6. HATCHING REPRESENTS THE EXPOSED AREA OF THE HEAT SLUG.

DIM	INCH		MILLIMETER		DIM	INCH		MILLIMETER	
	MIN	MAX	MIN	MAX		MIN	MAX	MIN	MAX
A	.122	.128	3.10	3.25	b	.184	.190	4.67	4.83
A1	.001	.004	0.02	0.10	b1	.010	.016	0.25	0.41
A2	.125	.131	3.18	3.33	c1	.007	.011	0.18	0.28
D	.928	.932	23.57	23.67	e	.020 BSC		0.51 BSC	
D1	.954	.958	24.23	24.33	e1	.040 BSC		1.02 BSC	
E	.429	.437	10.9	11.1	e2	.131 BSC		3.33 BSC	
E1	.353	.357	8.97	9.07	t	2*	8*	2*	8*
E2	.346	.350	8.79	8.89	aaa	.004		0.10	
E3	.132	.140	3.35	3.56					
L	.018	.024	0.46	0.61					
L1	.01 BSC		0.25 BSC						
M	.800	----	20.32	----					
N	.270	----	6.86	----					

© FREESCALE SEMICONDUCTOR, INC. ALL RIGHTS RESERVED.		MECHANICAL OUTLINE		PRINT VERSION NOT TO SCALE	
TITLE: TO-270 WIDE BODY LONG, 16 LEAD, GULL WING PLASTIC			DOCUMENT NO: 98ASA10740D		REV: C
			CASE NUMBER: 1867-02		18 MAY 2010
			STANDARD: NON-JEDEC		

PRODUCT DOCUMENTATION, SOFTWARE AND TOOLS

Refer to the following documents, tools and software to aid your design process.

Application Notes

- AN1955: Thermal Measurement Methodology of RF Power Amplifiers
- AN1977: Quiescent Current Thermal Tracking Circuit in the RF Integrated Circuit Family
- AN1987: Quiescent Current Control for the RF Integrated Circuit Device Family

Engineering Bulletins

- EB212: Using Data Sheet Impedances for RF LDMOS Devices

Software

- Electromigration MTTF Calculator
- RF High Power Model
- .s2p File

For Software and Tools, do a Part Number search at <http://www.freescale.com>, and select the "Part Number" link. Go to the Software & Tools tab on the part's Product Summary page to download the respective tool.

REVISION HISTORY

The following table summarizes revisions to this document.

Revision	Date	Description
0	Feb. 2011	• Initial Release of Data Sheet
1	Feb. 2011	• Corrected output power from 35 W CW to 35 W Avg. Two-Tone, Table 2, Thermal Characteristics, p. 2
2	May 2011	• Added part number MD8IC970GNR1 (TO-270 WBL-16 Gull), p. 1 • Added 1867-02 (TO-270 WBL-16 Gull) package isometric, p. 1, and mechanical outline, p. 13-15

How to Reach Us:

Home Page:

www.freescale.com

Web Support:

<http://www.freescale.com/support>

USA/Europe or Locations Not Listed:

Freescale Semiconductor, Inc.
Technical Information Center, EL516
2100 East Elliot Road
Tempe, Arizona 85284
1-800-521-6274 or +1-480-768-2130
www.freescale.com/support

Europe, Middle East, and Africa:

Freescale Halbleiter Deutschland GmbH
Technical Information Center
Schatzbogen 7
81829 Muenchen, Germany
+44 1296 380 456 (English)
+46 8 52200080 (English)
+49 89 92103 559 (German)
+33 1 69 35 48 48 (French)
www.freescale.com/support

Japan:

Freescale Semiconductor Japan Ltd.
Headquarters
ARCO Tower 15F
1-8-1, Shimo-Meguro, Meguro-ku,
Tokyo 153-0064
Japan
0120 191014 or +81 3 5437 9125
support.japan@freescale.com

Asia/Pacific:

Freescale Semiconductor China Ltd.
Exchange Building 23F
No. 118 Jianguo Road
Chaoyang District
Beijing 100022
China
+86 10 5879 8000
support.asia@freescale.com

For Literature Requests Only:

Freescale Semiconductor Literature Distribution Center
1-800-441-2447 or +1-303-675-2140
Fax: +1-303-675-2150
LDCForFreescaleSemiconductor@hibbertgroup.com

Information in this document is provided solely to enable system and software implementers to use Freescale Semiconductor products. There are no express or implied copyright licenses granted hereunder to design or fabricate any integrated circuits or integrated circuits based on the information in this document.

Freescale Semiconductor reserves the right to make changes without further notice to any products herein. Freescale Semiconductor makes no warranty, representation or guarantee regarding the suitability of its products for any particular purpose, nor does Freescale Semiconductor assume any liability arising out of the application or use of any product or circuit, and specifically disclaims any and all liability, including without limitation consequential or incidental damages. "Typical" parameters that may be provided in Freescale Semiconductor data sheets and/or specifications can and do vary in different applications and actual performance may vary over time. All operating parameters, including "Typicals", must be validated for each customer application by customer's technical experts. Freescale Semiconductor does not convey any license under its patent rights nor the rights of others. Freescale Semiconductor products are not designed, intended, or authorized for use as components in systems intended for surgical implant into the body, or other applications intended to support or sustain life, or for any other application in which the failure of the Freescale Semiconductor product could create a situation where personal injury or death may occur. Should Buyer purchase or use Freescale Semiconductor products for any such unintended or unauthorized application, Buyer shall indemnify and hold Freescale Semiconductor and its officers, employees, subsidiaries, affiliates, and distributors harmless against all claims, costs, damages, and expenses, and reasonable attorney fees arising out of, directly or indirectly, any claim of personal injury or death associated with such unintended or unauthorized use, even if such claim alleges that Freescale Semiconductor was negligent regarding the design or manufacture of the part.

Freescale™ and the Freescale logo are trademarks of Freescale Semiconductor, Inc. All other product or service names are the property of their respective owners.

© Freescale Semiconductor, Inc. 2011. All rights reserved.

Looking for pricing, stock, or lifecycle information?

Click below to explore more details on WIN SOURCE:

 [View MD8IC970NR1 on WIN SOURCE](#)

 [NXP / Nexperia Information](#)

Optimize Your Supply Chain with WIN SOURCE Solutions

-  Global Sourcing Solution
-  Obsolete Management
-  Cost Control Management
-  Shortage Management
-  Alternative Solution
-  Excess Inventory Management