

RFRP2920

Si Reverse Hybrid
5MHz to 100MHz (Low Current)

The RFRP2920 is a hybrid reverse amplifier. The part employs a silicon die. It has extremely low distortion and superior return loss performance. The part also provides optimal reliability with low noise and is well suited for 5MHz to 100MHz CATV amplifiers for reverse channel systems.

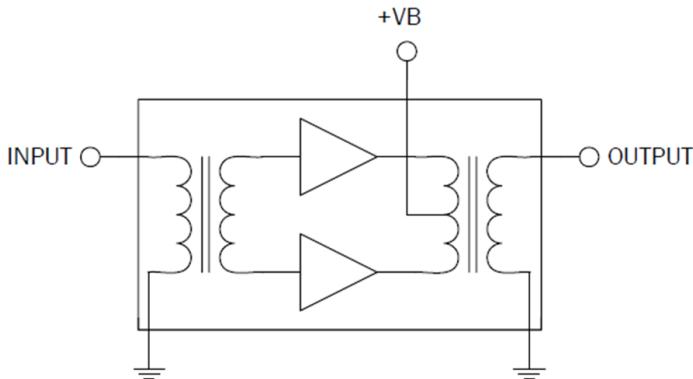

Package: SOT-115J

Features

- Excellent Linearity
- Superior Return Loss Performance
- Extremely Low Distortion
- Optimal Reliability
- Low Noise
- Unconditionally Stable Under All Terminations
- 38.3dB Typ. Gain at 100MHz
- 160mA Max. at 24V_{DC}

Applications

- 5MHz to 100MHz CATV Amplifier For Reverse Channel Systems

Ordering Information

RFRP2920 Box with 50 Pieces

Absolute Maximum Ratings

Parameter	Rating	Unit
RF Input Voltage (single tone)	65	dBmV
DC Supply Over-Voltage (5 minutes)	30	V
Storage Temperature	-40 to +100	°C
Operating Mounting Base Temperature	-30 to +100	°C



Caution! ESD sensitive device.



RoHS (Restriction of Hazardous Substances): Compliant per EU Directive 2011/65/EU.

Exceeding any one or a combination of the Absolute Maximum Rating conditions may cause permanent damage to the device. Extended application of Absolute Maximum Rating conditions to the device may reduce device reliability. Specified typical performance or functional operation of the device under Absolute Maximum Rating conditions is not implied.

Nominal Operating Parameters

Parameter	Specification			Unit	Condition
	Min	Typ	Max		
General Performance					V+ = 24V; T_{MB} = 30°C; Z_S = Z_L = 75Ω
Power Gain	37.8	38.3	38.6	dB	f = 5MHz
	37.6	38.3		dB	f = 100MHz
Slope ^[1]	-0.2	0	0.5	dB	f = 5MHz to 100MHz
Flatness of Frequency Response			±0.3	dB	
Input Return Loss	20.0			dB	
Output Return Loss	20.0			dB	
Noise Figure		3.8	4.2	dB	f = 100MHz
Total Current Consumption (DC)	150.0	158.0	160.0	mA	
Distortion Data 5MHz to 100MHz					V+ = 24V; T_{MB} = 30°C; Z_S = Z_L = 75Ω
CTB			-72	dBc	7 ch flat; V _O = 50dBmV ^[2]
			-69	dBc	12 ch flat; V _O = 50dBmV ^[3]
XMOD			-64	dB	7 ch flat; V _O = 50dBmV ^[2]
			-61	dB	12 ch flat; V _O = 50dBmV ^[3]
CSO			-70	dBc	7 ch flat; V _O = 50dBmV ^[2]
			-68	dBc	12 ch flat; V _O = 50dBmV ^[3]
d ₂			-70	dBc	[4]
STB			-72	dB	[5]

1. The slope is defined as the difference between the gain at the start frequency and the gain at the stop frequency.

2. 7 channels, US frequency raster: T7 - T13 (7.0MHz to 43.0MHz), +50dBmV flat output level.

3. 12 channels, US frequency raster: T7 - T13 (7.0MHz to 43.0MHz), 2 - 6 (55.25MHz to 83.25MHz), +50dBmV flat output level.

4. f₁ = 7MHz; V₁ = 50dBmV; f₂ = 25MHz; V₂ = 50dBmV; f_{TEST} = f₁ + f₂ = 32MHz.

5. f₁ = 13MHz; V₁ = 50dBmV; f₂ = 25MHz; V₂ = V₁; f₃ = 7MHz; V₃ = V₁; f_{TEST} = f₁ + f₂ - f₃ = 31MHz.

Composite Second Order (CSO) - The CSO parameter (both sum and difference products) is defined by the NCTA.

Composite Triple Beat (CTB) - The CTB parameter is defined by the NCTA.

Cross Modulation (XMOD) - Cross modulation (XMOD) is measured at baseband (selective voltmeter method), referenced to 100% modulation of the carrier being tested.

Package Drawing (Dimensions in millimeters)

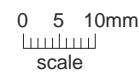
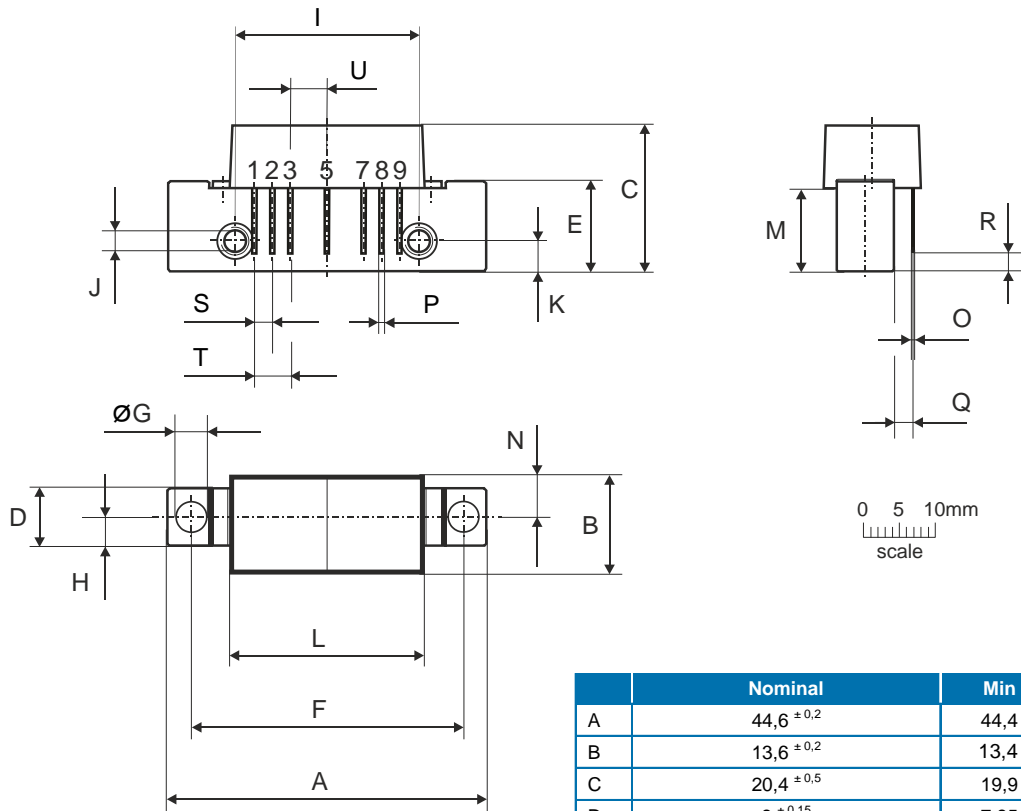

Notes:

European Projection

Pinning:

Pin	Name
1	Input
2-3	GND
4	
5	+VB
6	
7-8	GND
9	Output

	Nominal	Min	Max
A	44,6 ± 0,2	44,4	44,8
B	13,6 ± 0,2	13,4	13,8
C	20,4 ± 0,5	19,9	20,9
D	8 ± 0,15	7,85	8,15
E	12,6 ± 0,15	12,45	12,75
F	38,1 ± 0,2	37,9	38,3
G	4 ^{+0,2 / -0,05}	3,95	4,2
H	4 ± 0,2	3,8	4,2
I	25,4 ± 0,2	25,2	25,6
J	UNC 6-32	-	-
K	4,2 ± 0,2	4,0	4,4
L	27,2 ± 0,2	27,0	27,4
M	11,6 ± 0,5	11,1	12,1
N	5,8 ± 0,4	5,4	6,2
O	0,25 ± 0,02	0,23	0,27
P	0,45 ± 0,03	0,42	0,48
Q	2,54 ± 0,3	2,24	2,84
R	2,54 ± 0,5	2,04	3,04
S	2,54 ± 0,25	2,29	2,79
T	5,08 ± 0,25	4,83	5,33
U	5,08 ± 0,25	4,83	5,33

Looking for pricing, stock, or lifecycle information?

Click below to explore more details on WIN SOURCE:

 [View RFRP2920 on WIN SOURCE](#)

 [Qorvo US Inc. Information](#)

Optimize Your Supply Chain with WIN SOURCE Solutions

-  Global Sourcing Solution
-  Obsolete Management
-  Cost Control Management
-  Shortage Management
-  Alternative Solution
-  Excess Inventory Management