

6ch White LED Driver Built-in Current Driver Boost DC/DC Converter for Automotive

BD82A26MUF-M

General Description

This IC is a white LED driver for LCD backlight. It has 6ch current drivers for LED drive, making it ideal for high brightness LED drive. LED pin maximum voltage is 50 V, making it suitable for driving large LCD panels. The dimming is controlled by the PWM signal and can be set up to 20,000: 1@100 Hz. It also supports analog dimming, and can accommodate even higher brightness ranges by combining with PWM dimming. DC/DC converters can be controlled for boost applications, and the input operating voltage range is 3.0 V to 48 V.

Features

- Nano Cap™ Integrated^(Note 1)
- AEC-Q100 Qualified^(Note 2)
- Functional Safety Supportive Automotive Products
- Current Driver for LED Drive 6ch
- Current Mode Boost DC/DC Converters
- Load Switch (M1) Control Pin
- PWM Dimming (20,000: 1@100 Hz, 100 Hz to 25 kHz)
- Analog + PWM Mix Dimming Available
- Spread Spectrum Function
- DC/DC Converter Oscillation Frequency External Synchronization Function
- LSI Protect Functions (UVLO, OVP, TSD, OCPL)
- LED Anode/Cathode Short Circuit Protection Function
- LED Open/Short Protection Function

(Note 1) Nano Cap™ is a trademark or a registered trademark of ROHM Co., Ltd. Nano Cap™ is a combination of technologies which allow stable operation even if output capacitance is connected with the range of nF unit.

(Note 2) Grade 1

Key Specifications

- Input Operating Voltage Range: 3.0 V to 48 V
- Output LED Current Absolute Accuracy: ±5.0 %@80 mA
- DC/DC Oscillation Frequency: 200 kHz to 2420 kHz
- Operating Temperature: -40 °C to +125 °C
- LED Maximum Current: 150 mA/ch
- LED Maximum Dimming Ratio: 20,000: 1@100 Hz
- LED1 to LED6 Pin Maximum Voltage: 50 V

Package

VQFN32FBV050

W (Typ) x D (Typ) x H (Max)

5.0 mm x 5.0 mm x 1.0 mm

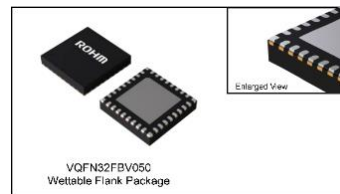

Applications

- Automotive CID (Center Information Display) Panel
- Navigation
- Cluster Panel
- HUD (Head Up Display)
- Other Small and Medium Sized LCD Panels for Automotive

Typical Application Circuit

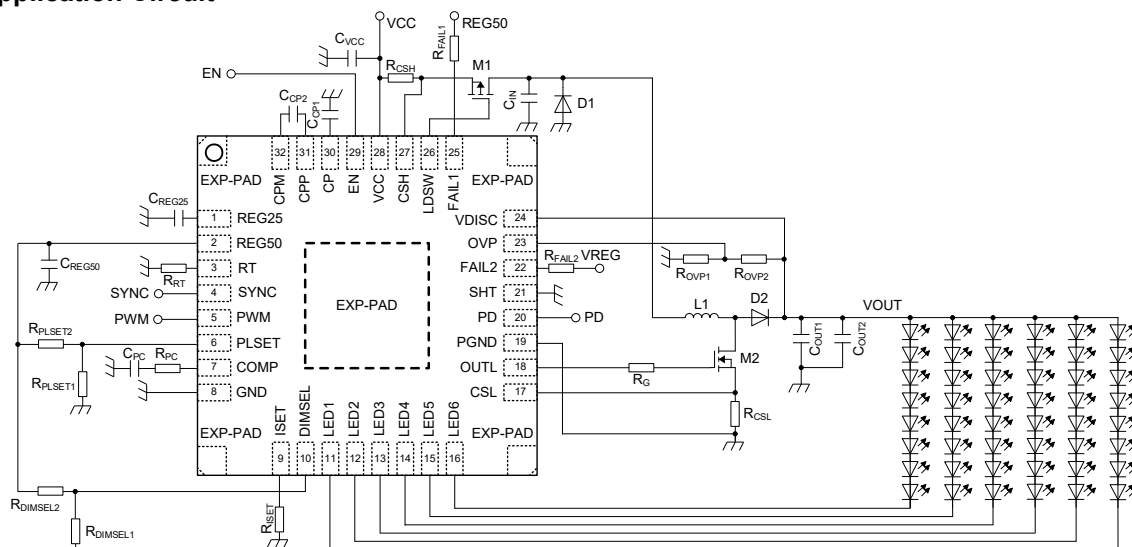

Figure 1. Boost Application Circuit Diagram

○Product structure : Silicon integrated circuit ○This product has no designed protection against radioactive rays.

○This product is protected by U.S. Patent No.7,235,954, No.7,541,785, No.7,944,189 and No.10,068,511.

www.rohm.com

© 2021 ROHM Co., Ltd. All rights reserved.

TSZ22111 • 14 • 001

Contents

General Description	1
Features	1
Key Specifications	1
Package	1
Applications	1
Typical Application Circuit.....	1
Contents	2
Pin Configuration	3
Pin Descriptions	3
Block Diagram	5
Description of Blocks	6
Absolute Maximum Rating	11
Thermal Resistance	11
Recommended Operating Conditions	12
Operating Conditions (External Constant Range).....	12
Electrical Characteristics.....	13
Typical Performance Curves.....	17
Functional Descriptions	19
PCB Application Circuit Diagram	36
List of External Components.....	37
Power Consumption Calculation Example	39
I/O Equivalence Circuit	40
Operational Notes	41
Ordering Information.....	43
Marking Diagram	43
Physical Dimension and Packing Information	44
Revision History.....	45

Pin Configuration

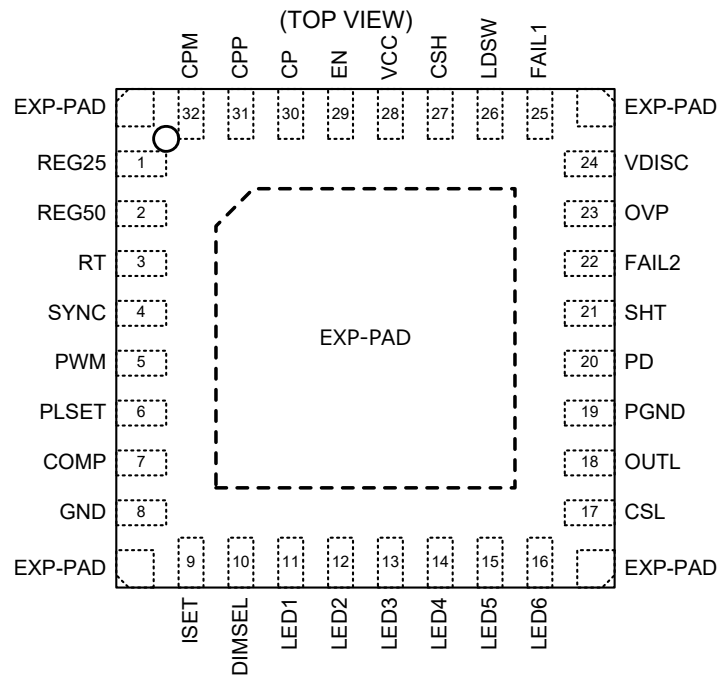

Pin Descriptions

Pin No.	Pin Name	Signal type (Note 1)	Function
1	REG25	A	Internal reference voltage 1: Used as the reference voltage for the internal circuit and charge pump.
2	REG50	A	Internal reference voltage 2: Used as the reference voltage for the internal circuit. 5 V is generated and output by setting the EN pin to High. Connect a capacitance of 2.2 μ F for phase compensation.
3	RT	A	Resistor connection for oscillation frequency setting: The oscillation frequency (f_{OSC}) of DC/DC converter can be set by connecting a resistor (R_{RT}) between the RT pin and the GND pin.
4	SYNC	I	External synchronization frequency input / SSCG setting: The internal oscillation frequency can be externally synchronized by inputting an external clock signal to the SYNC pin before the Self Diagnosis is completed. When using spread spectrum mode (SSCG), short the SYNC pin and the REG50 pin beforehand.
5	PWM	I	PWM dimming signal: The LED current can be controlled according to On Duty of the input PWM signal.
6	PLSET	A	Switching pulse number setting: Addition pulse function is provided to stabilize DC/DC converter output voltage even when PWM Duty is low. The number of switching pulses to be added can be set by the resistance value connected to the PLSET pin.
7	COMP	A	Phase compensation capacitor connection: The reference voltage and LED pin voltage generated by REF Voltage block are compared and output by Error AMP. Connect a filter for phase compensation.
8	GND	A	Small Signal Ground: Use to ground for the external components connected to the REG25, REG50, RT, PLSET, COMP, ISET, DIMSEL, PD, SHT, and OVP pins.
9	ISET	A	Resistor connection for LED current setting: LED current (I_{LED}) can be set by connecting a resistor (R_{ISET}) between the ISET pin and the GND pin.
10	DIMSEL	A	DC dimming setting: The point at which PWM dimming and DC dimming are switched can be set by the resistor connected between the DIMSEL pin and the GND pin. When using only PWM dimming, short the DIMSEL pin with the GND pin.
11	LED1	P	LED cathode connection 1: Open drain output of the current driver ch1 for LED drive. Connect to the LED cathode.
12	LED2	P	LED cathode connection 2: Open drain output of the current driver ch2 for LED drive. Connect to the LED cathode.
13	LED3	P	LED cathode connection 3: Open drain output of the current driver ch3 for LED drive. Connect to the LED cathode.

(Note 1) A: Sensitive signal such as detect and reference, I: Input signal from other units P: High current signal susceptible to impedance, including transient current.

Pin Descriptions – continued

Pin No.	Pin Name	Signal type (Note 1)	Function
14	LED4	P	LED cathode connection 4: Open drain output of the current driver ch4 for LED drive. Connect to the LED cathode.
15	LED5	P	LED cathode connection 5: Open drain output of the current driver ch5 for LED drive. Connect to the LED cathode.
16	LED6	P	LED cathode connection 6: Open drain output of the current driver ch6 for LED drive. Connect to the LED cathode.
17	CSL	A	Overcurrent protection detection input: The current flowing through Low side FET (M2) is converted to voltage by the low side current detection resistor (R_{CSL}) and detected by the CSL pin. When the overcurrent protection (OCPL) is activated, DC/DC converters are switched OFF.
18	OUTL	P	Low side FET gate signal: Switching signal output of DC/DC converter. The OUTL pin should be connected to Low side FET (M2) gate.
19	PGND	P	Large current ground: Use for ground for external components connected to the CSL and OUTL pins.
20	PD	A	Phase Delay setting: Connect the PD pin to the REG50 pin when using the Phase Delay function. Connect the PD pin to the GND pin when the phase delay function is not used.
21	SHT	A	Resistor connection for LED short protection setting: LED short detection voltage can be set by connecting a resistor (R_{SHT}) between the SHT pin and the GND pin. When LED short protection is activated, the current driver is turned OFF only for the corresponding LED column.
22	FAIL2	O	Error output flag 2: Outputs the status of protective operation from the FAIL1 pin and the FAIL2 pin. Since these pins are open drain outputs, pulling up to the REG50 pin is recommended.
23	OVP	A	Overvoltage protection and short circuit protection detection input: When OVP pin voltage rises to 1.0 V or more, overvoltage protection (OVP) is activated, and DC/DC converters are switched OFF. If OVP pin voltage is 0.3 V or less for 13.1 ms, Short Circuit Protection (SCP) is activated, and both DC/DC converter and the current driver are turned OFF.
24	VDISC	P	VOUT discharge: Connects to the output of DC/DC converters. When UVLO, TSD, or SCP protective operation is performed, or when PWM Low section is monitored and the operation OFF status is detected, DC/DC output voltage is discharged from the VDISC pin.
25	FAIL1	O	Error output flag 1: Outputs the status of protective operation from the FAIL1 pin and the FAIL2 pin. Since these pins are open drain outputs, we recommend pulling them up to the REG50 pin.
26	LDSW	P	Output for driving the load switch gate: This is the signal output for driving the gate of the load switch. When the input overcurrent protection (OCPL) is activated, the load switch is turned OFF as LDSW pin voltage = VCC voltage.
27	CSH	A	Input current detection input: The input current is converted to voltage by the input current detection resistor (R_{CSH}) connected between the VCC-CSH pin, and detected by the CSH pin. Turns the load switch OFF when the input overcurrent protection is activated.
28	VCC	P	Power supply voltage input: The input operating voltage range is 3.0 V to 48 V, but when the IC is started, $VCC \geq 5.0$ V should be used. The decoupling capacitor (C_{VCC}) between the VCC pin and the GND pin should be close to the IC pin.
29	EN	I	Enable input: The EN pin is turned High to activate the internal circuit. The EN pin is judged as Low level at 0.5 V or less, and judged as High level at 2.3 V or more. Avoid using a constant two state input ($0.5 \text{ V} \leq V_{EN} \leq 2.3 \text{ V}$).
30	CP	P	Charge pump output: Connect a capacitance (C_{CP1}) between the CP pin and the PGND pin.
31	CPP	P	Flying capacitor connection + side: Connect a capacitance (C_{CP2}) between the CPP pin and the CPM pin.
32	CPM	P	Flying capacitor connection - side: Connect a capacitance (C_{CP2}) between the CPP pin and the CPM pin.
-	EXP-PAD	-	The center EXP-PAD should be connected to the board ground. The center EXP-PAD and corner EXP-PAD are shorted inside the packaging.

(Note 1) **A:** Sensitive signal such as detect and reference, **I:** Input signal from other units, **O:** Output signal to other units, **P:** High current signal susceptible to impedance, including transient current.

Description of Blocks

Unless otherwise stated, the value in the sentence is the typical value.

1 VREF

Internal reference voltage circuit. By setting the EN pin to High, 5 V is generated and output to the REG50 pin. REG50 voltage is used as the power supply for the internal circuit. Also, this is used to fix each input pin to High voltage outside the IC. Connect $C_{REG50} = 2.2 \mu\text{F}$ to the REG50 pin as the capacitance for the phase compensation. Note that if C_{REG50} is not connected, unstable operation such as oscillation will occur.

2 LDSW Driver

Input overcurrent protection circuit. If the voltage between the VCC-CSH pin is 0.2 V or more and continues for 10 μs or more, the input overcurrent protection is activated, and the load switch (M1) is turned OFF as LDSW pin voltage = VCC voltage. Then, after 13.1 ms elapses, the load switch is turned ON. At this time, if the voltage between VCC-CSH is 0.2 V or more, the load switch is turned OFF again. If the voltage between VCC-CSH is 0.2 V or less, Self Diagnosis is performed and restarted. For Self Diagnosis, refer to "[3 Startup Characteristics and Effective Section of Each Protection Function](#)". Only the FAIL2 pin goes Low when the input overcurrent protection is detected.

3 VOUT Discharge

Output voltage discharge circuit. The LEDs may flicker if activated with charges remaining on VOUT. Therefore, VOUT must be discharged at startup. Discharge times may be prolonged only by discharge paths such as the resistor for OVP setting, so an output voltage discharge circuit ([VOUT discharge function](#)) is provided. Residual charges in the output are discharged when DC/DC converters are turned OFF (when the EN falls or the protective function is activated).

4 OSC (Oscillator)

Oscillation frequency generator. [The oscillation frequency \(\$f_{osc}\$ \) of DC/DC converter](#) can be set by connecting a resistor for oscillation frequency setting (R_{RT}) between the RT pin and ground. In addition, the oscillation frequency of DC/DC converter can be externally synchronized by inputting [the external synchronization frequency \(\$f_{sync}\$ \)](#) to the SYNC pin. Input the clock signal to be input from the SYNC pin before the Self Diagnosis is completed. For Self Diagnosis, refer to "[3 Startup Characteristics and Effective Section of Each Protection Function](#)".

5 SSCG (Spread Spectrum Clock Generator)

Spread spectrum circuit. [The spread spectrum function \(SSCG\)](#) is activated by shorting the SYNC pin and the REG50 pin. Noise peaks can be reduced by periodically changing the oscillation frequency by SSCG. The fluctuation range of the frequency due to SSCG is from 100 % to 92 % of the set oscillation frequency. The oscillation frequency fluctuation cycle is 128/set oscillation frequency.

6 SLOPE

This circuit generates a saw wave that serves as the source of the switching pulse of DC/DC converter. SLOPE output signal and COMP pin voltage are compared and a switching pulse is generated.

7 Minimum Channel Selector

Selector circuit for detecting LED pin voltages. Selects the lowest pin voltage among LED1 to LED6 pin voltages and input it in Error AMP.

8 Error AMP (Error Amplifier)

This is an error amplifier that takes the smallest values of the LED1 to LED6 pin voltage and LED control voltage as inputs. Phase compensation can be set by connecting a resistor and a capacitor to the COMP pin.

9 Soft Start

Soft start circuit for DC/DC converters. This function is used to suppress a steep increase in the coil current at startup and an overshoot in the output voltage. Controls the change in switching Duty by limiting the rising edge of the output of Error AMP (COMP pin voltage).

10 PWM COMP (PWM Comparator)

This comparator compares COMP pin voltage, which is the output of Error AMP, with SLOPE output signal. Controls the duty of the switching pulse of DC/DC converter.

11 Additional Pulse

This circuit adds switching pulses for DC/DC converters. With [the Additional pulse function](#), the LED current can be supplied stably even when the PWM dimming ratio decreases.

12 DC/DC Control LOGIC

This circuit generates the final logic of Low side FET gate signal output from the OUTL pin.

Description of Blocks - continued

13 Internal CLK

This circuit generates the internal reference clock. It is a clock of 20 MHz and used as a counter or sampling frequency.

14 Phase Delay

This circuit shifts the phase of LED pin output during PWM dimming. [Phase Delay function](#) can be used by shorting the PD pin to the REG50 pin.

15 Dimming Control

This circuit controls the dimming ratio during PWM dimming. PWM dimming and DC dimming can be automatically switched [PWM dimming and DC dimming can be automatically switched](#) and controlled by applying a voltage (resistor division of REG50) to the DIMSEL pin. This provides both minute dimming (PWM dimming) at low brightness levels and support for high brightness ranges (DC dimming).

16 Charge Pump

Charge pump circuit. The charge pump output voltage is used for the output drive voltage of the current driver, and can output a stable LED current even when the VCC input voltage is low. By connecting the capacitance (C_{CP1}) between the CP pin and ground and the capacitance (C_{CP2}) between the CPP-CPM pin, a voltage twice the REG25 pin voltage can be output from the CP pin. 10 μ F is recommended for C_{CP1} and 2.2 μ F is recommended for C_{CP2} . When the charge pump function is not used, do not connect capacitance between the CPP-CPM pin and short-circuit the CP pin with the REG50 pin.

17 Current Driver / ISET

Current driver circuit for lighting the LED. The LED current can be set by connecting a resistor to the ISET pin.

18 PROTECT

Outputs the status of protective operation from the FAIL1 pin and the FAIL2 pin. Since these pins are open drain outputs, connect them to the REG50 pin with resistors. If the protection status is not monitored, turn the FAIL1 pin and the FAIL2 pin to OPEN or connect to the GND pin.

18.1 UVLO (Under Voltage Lockout)

Under Voltage Lockout. When the VCC is 2.8 V or less or the REG50 pin voltage is 2.7 V or less, Under Voltage Lockout (UVLO) is activated, and the load switch (M1), DC/DC converter, and current driver turn OFF. When VCC becomes 3.2 V or more and the REG50 pin voltage becomes 3.1 V or more, UVLO is released and the IC restarts from Self Diagnosis. When a UVLO is detected, the outputs of the FAIL1 pin and the FAIL2 pin do not change. When the FAIL1 pin and the FAIL2 pin are pulled up to REG50, FAIL1 pin and FAIL2 pin voltage will also drop as REG50 decreases.

18.2 TSDLED (Thermal Shutdown for Current Driver)

This is a temperature protection circuit that monitors the vicinity of the current driver on the chip. Prevents chip temperature from rising due to abnormal output current. When the chip temperature rises to 175 °C or more, the temperature protection circuit (TSDLED) is activated, the load switch (M1), DC/DC converter, and current driver are turned OFF, and only the FAIL2 pin is turned Low. When the chip temperature falls 150 °C or less, TSDLED is released, the IC restarts from Self Diagnosis, and the FAIL2 pin returns to High.

18.3 TSDREG (Thermal Shutdown for REG50)

This is a temperature protection circuit that monitors the vicinity of the REG50 pin on the chip. Prevents chip temperature rising due to the REG50 pin failure. When the chip temperature rises to 175 °C or more, the temperature protection circuit (TSDREG) is activated, and REG50 pin voltage, load switch (M1), DC/DC converter, and current driver turn OFF. When the FAIL1 pin and the FAIL2 pin are pulled up to the REG50 pin, FAIL1 pin and FAIL2 pin voltages drop as REG50 pin voltage is turned OFF, and both are output to the Low level. When the FAIL1 pin and the FAIL2 pin are pulled up to an external power supply, both the FAIL1 pin and the FAIL2 pin are output to High. When the chip temperature falls 150 °C or less, TSDREG is released and the IC restarts from Self Diagnosis.

18.4 TW (Thermal Warning)

Thermal Warning Circuit. When the chip temperature rises to 140 °C or more, the Thermal Warning Circuit (TW) activates and only the FAIL1 pin goes Low. When the chip temperature falls 130 °C or less, the TW is released and the FAIL1 pin returns to High.

18. PROTECT – continued**18.5 OCPL (Over Current Protection for Low side)**

The voltage is detected by the low side current detection resistor (R_{CSL}) for the current flowing through Low side FET (M2). When CSL pin voltage rises to 0.3 V or more, the overcurrent protection (OCPL) is activated and only the switching of DC/DC converter is stopped. If CSL pin voltage falls less than 0.3 V, the overcurrent protection is released and switching resumes. When the OCPL is detected, the outputs of the FAIL1 pin and the FAIL2 pin do not change.

18.6 OVP (Over Voltage Protection)

Output overvoltage protection circuit. When OVP pin voltage (resistor division of DC/DC converter output voltage) becomes 1.0 V or more, the output overvoltage protection circuit (OVP) activates and only the switching of DC/DC converter is stopped. When OVP pin voltage falls 0.95 V or less, OVP is released. Only the FAIL1 pin goes Low when OVP is detected.

18.7 OPEN Det (LED Open Detection)

LED open protection circuit. When any of LED1 to LED6 pin voltages is 0.3 V or less and OVP pin voltage is 1.0 V or more, the LED open protection (OPEN Det) is activated and the current driver is latched OFF only for the corresponding LED column. LED open protection is released when V_{EN} = Low or UVLO is detected. When LED open is detected, only the FAIL2 pin goes Low.

18.8 SHORT Det (LED Short Detection)

LED short protection circuit. When LED pin voltage is higher than the threshold set by the SHT pin for 13.1 ms, the LED short protection (SHORT Det) is activated and the current driver is latched OFF only for the corresponding LED column. The counter is reset when LED pin voltage does not satisfy the detection condition prior to the LED short protection being activated. 10 times the voltage input to the SHT pin becomes the short detection threshold. When the SHT pin is connected to GND, the short detection threshold is 4.5 V. Short the SHT pin to GND or set to the voltage application state and do not set it to OPEN status. LED short protection is released when V_{EN} = Low or a UVLO is detected. Counters of 13.1 ms are counted up only when Duty of LED current is ON. Therefore, the duration until LED short protection is detected varies depending on the input PWM Duty and [PWM-DC dimming switching point](#). Only the FAIL2 pin goes Low when LED short protection is detected. LED short protection is detectable when ON pulse width of the LED current is 20 μ s or more.

18.9 SCP (Short Circuit Protection)

Short Circuit Protection circuit. If any of the LED1 to LED6 pin is 0.3 V or less or OVP pin voltage is 0.3 V or less for 13.1 ms, the Short Circuit Protection (SCP) is activated, and the load switch (M1), DC/DC converter, and current driver turn OFF. However, the counters are reset when each pin voltage no longer satisfies the requirement prior to the SCP is activating. The SCP is released when V_{EN} = Low or a UVLO is detected. When SCP is detected, only the FAIL2 pin goes Low.

DC/DC converters also attempt to output a higher voltage because the grounded LED pin voltage (lowest LED pin voltage) is controlled to be V_{LEDCTL} . Depending on the power supply voltage and load conditions, the OVP pin may become 1.0 V or more prior to the SCP being activated, and the LED open protection may be activated first. In this case, the current driver will be turned OFF only in the grounded LED pin, but the LEDs will remain lighting with the current control lost because of a short circuit as well. Even when LED open protection is detected, the FAIL2 pin goes Low. Abnormality can be detected by monitoring this.

18.10 OCPH (Over Current Protection for High side) / LDSW Driver

Input overcurrent protection circuit. If a condition in which the voltage between the VCC-CSH pin is 0.2 V or more continues for 10 μ s or more, the input overcurrent protection (OCPH) is activated, and the load switch (M1), DC/DC converter, and current driver turn OFF. Then, after 13.1 ms elapses, the load switch is turned ON. At this time, if the voltage between VCC-CSH is 0.2 V or more, the load switch, DC/DC converter, and current driver are turned OFF again. If the voltage between VCC-CSH is less than 0.2 V, Self Diagnosis is performed and restarted. For Self Diagnosis, refer to "[3 Startup Characteristics and Effective Section of Each Protection Function](#)". When the input overcurrent protection is detected, the FAIL2 pin goes Low.

18 PROTECT – continued**18.11 ISET Pin Fault Protection (ISET-GND Short Circuit Protection)**

ISET pin fault protection circuit. When the resistance value connected to the ISET pin becomes 1 k Ω or less, ISET error protection is activated, and the load switch (M1), DC/DC converter, and current driver are turned OFF. When the resistor connected to the ISET pin becomes 15 k Ω or more, ISET error protection is released, and the load switch (M1), DC/DC converter, and current driver turn ON. When ISET-GND short protection is detected, only the FAIL2 pin goes Low.

18.12 OVP Pin Fault Protection

OVP pin fault protection circuit. If OVP pin voltage is 2.3 V or more or 0.2 V or less or VDISC pin voltage is 47.5 V or more in the Self Diagnosis status after the EN pin starts, OPEN/SHORT error of the resistor connected to OVP is detected and OVP pin fault protection is activated. At this time, the load switch (M1), DC/DC converter, and current driver turn OFF. When V_{EN} = Low or a UVLO is detected, OVP pin fault protection is released. When OVP pin fault protection is detected, both the FAIL1 pin and the FAIL2 pin are set to Low.

Description of Blocks - continued

Detect Conditions and Operation at Detection of Each Protection Function (All values in the table are typical values)

No.	Function	Detect Condition		Detect Operation				
		[Detect]	[Release]	Load Switch	DC/DC Switching	Current Driver	FAIL1 (Note 1)	FAIL2 (Note 1)
1	Under Voltage Lockout (UVLO)	$V_{CC} \leq 2.8 \text{ V}$ or $V_{REG50} \leq 2.7 \text{ V}$	$V_{CC} \geq 3.2 \text{ V}$ and $V_{REG50} \geq 3.1 \text{ V}$	OFF	OFF	OFF	High	High
2	Thermal Shutdown (TSDLED)	$T_j \geq 175 \text{ }^\circ\text{C}$	$T_j \leq 150 \text{ }^\circ\text{C}$	OFF	OFF	OFF	High	Low
3	Thermal Shutdown ^(Note 2) (TSDREG)	$T_j \geq 175 \text{ }^\circ\text{C}$	$T_j \leq 150 \text{ }^\circ\text{C}$	OFF	OFF	OFF	Low (Note 2)	Low (Note 2)
4	Thermal Warning (TW)	$T_j \geq 140 \text{ }^\circ\text{C}$	$T_j \leq 130 \text{ }^\circ\text{C}$	ON	ON	ON	Low	High
5	Overcurrent Protection (OCPL)	$V_{CSL} \geq 0.3 \text{ V}$	$V_{CSL} < 0.3 \text{ V}$	ON	OFF	ON	High	High
6	Overvoltage Protection (OVP)	$V_{OVP} \geq 1.0 \text{ V}$	$V_{OVP} \leq 0.95 \text{ V}$	ON	OFF	ON	Low	High
7	LED Open Protection (OPEN Det)	$V_{LEDn} \leq 0.3 \text{ V}$ and $V_{OVP} \geq 1.0 \text{ V}$ ^(Note 6)	Detects $V_{EN} = \text{Low}$ or UVLO	ON	ON	Detect LED Pin OFF	High	Latch Low
8	LED Short Protection (SHORT Det)	Detects $V_{LEDn} \geq V_{SHT} \times 10$ and $V_{LEDn} \geq 4.5 \text{ V}$ for 13.1 ms or more ^{(Note 3)(Note 6)}	Detects $V_{EN} = \text{Low}$ or UVLO	ON	ON	Detect LED Pin OFF	High	Latch Low
9	Short Circuit Protection (SCP) ^(Note 4)	Detects $V_{LEDn} \leq 0.3 \text{ V}$ or $V_{OVP} \leq 0.3 \text{ V}$ for 13.1 ms or more ^(Note 6)	Detects $V_{EN} = \text{Low}$ or UVLO	OFF	OFF	OFF	High	Latch Low
10	Input Overcurrent Protection (OCPH) ^(Note 4)	Detects $V_{CC} - V_{CSH} \geq 0.2 \text{ V}$ for 10 μs or more	$V_{CC} - V_{CSH} < 0.2 \text{ V}$	OFF	OFF (Note 5)	OFF (Note 5)	High	Low
11	ISET Pin Fault Protection (ISET SCP)	$R_{ISET} \leq 1.0 \text{ k}\Omega$	$R_{ISET} \geq 15 \text{ k}\Omega$	OFF	OFF	OFF	High	Low
12	OVP Pin Fault Protection	At Self Diagnosis $V_{OVP} \geq 2.3 \text{ V}$ or $V_{OVP} \leq 0.2 \text{ V}$ or $V_{DISC} \geq 47.5 \text{ V}$	Detects $V_{EN} = \text{Low}$ or UVLO	OFF	OFF	OFF	Latch Low	Latch Low

(Note 1) When the EN pin is Low, if FAIL1, FAIL2 is pulled up to the REG50 pin, FAIL1 = Low, FAIL2 = Low. When FAIL1, FAIL2 is pulled up to an external power supply, FAIL1 = High, FAIL2 = High.

(Note 2) Thermal shutdown (TSDREG) detects heat generation in the event of the REG50 pin failure and turns all circuit OFF, including the REG50 pin. When FAIL1, FAIL2 is pulled up to the REG50 pin, FAIL1 = Low, FAIL2 = Low. When FAIL1, FAIL2 is pulled up to an external power supply, FAIL1 = High, FAIL2 = High.

(Note 3) LED pin voltage of at least 1ch shall be less than $V_{LEDCTL(Min)} \times 1.1$. When LED pin voltages of all channels are 1.4 V or more, the LED short protection does not operate. In addition, since the 13.1 ms counter is counted up only when Duty of the LED current is ON, the time until SHORT Det is detected varies depending on PWM Duty.

(Note 4) When Short Circuit Protection (SCP) and input overcurrent protection (OCPH) are detected at the same time, the operation of input overcurrent protection takes precedence.

(Note 5) When 13.1 ms elapses after the load switch is turned OFF, the load switch turns ON. At this time, when the voltage between $V_{CC} - CSH \geq 0.2 \text{ V}$, the load switch is turned OFF again. When the voltage between $V_{CC} - CSH < 0.2 \text{ V}$, Self Diagnosis is performed and restarted. For Self Diagnosis, refer to "[3 Startup Characteristics and Effective Section of Each Protection Function](#)".

(Note 6) n = 1 to 6

Absolute Maximum Rating (Ta = 25 °C)

Parameter	Symbol	Rating	Unit
OVP, VDISC, LDSW, CSH, VCC Pin Voltage	V _{OVP} , V _{VDISC} , V _{LDSW} , V _{CSH} , V _{VCC}	-0.3 to +50	V
Voltage Between VCC-LDSW Pin	V _{VCC - VLDSW}	-0.3 to +7.0	V
LED1, LED2, LED3, LED4, LED5, LED6 Pin Voltage	V _{LED1} , V _{LED2} , V _{LED3} , V _{LED4} , V _{LED5} , V _{LED6}	-0.3 to +50	V
RT, PLSET, COMP, ISET, DIMSEL, CSL, OUTL Pin Voltage	V _{VRT} , V _{VPLSET} , V _{VCOMP} , V _{VISSET} , V _{VDIMSEL} , V _{VCSL} , V _{VOUTL}	-0.3 to V _{REG50}	V
REG25, REG50 Pin Voltage	V _{VREG25} , V _{VREG50}	-0.3 to +7.0	V
SYNC, PWM, PD, SHT, FAIL2, FAIL1, EN, CP, CPP, CPM Pin Voltage	V _{VSYNC} , V _{VPWM} , V _{VPD} , V _{VSHT} , V _{VFAIL2} , V _{VFAIL1} , V _{VEN} , V _{VCP} , V _{VCPP} , V _{VCPM}	-0.3 to +7.0	V
Storage Temperature Range	T _{stg}	-55 to +150	°C
Maximum Junction Temperature	T _{jmax}	150	°C

Caution 1: Operating the IC over the absolute maximum ratings may damage the IC. The damage can either be a short circuit between pins or an open circuit between pins and the internal circuitry. Therefore, it is important to consider circuit protection measures, such as adding a fuse, in case the IC is operated over the absolute maximum ratings.

Caution 2: Should by any chance the maximum junction temperature rating be exceeded the rise in temperature of the chip may result in deterioration of the properties of the chip. In case of exceeding this absolute maximum rating, design a PCB with thermal resistance taken into consideration by increasing board size and copper area so as not to exceed the maximum junction temperature rating.

Thermal Resistance^(Note 1)

Parameter	Symbol	Thermal Resistance (Typ)		Unit
		1s ^(Note 3)	2s2p ^(Note 4)	
VQFN32FBV050				
Junction to Ambient	θ_{JA}	97.3	30.7	°C/W
Junction to Top Characterization Parameter ^(Note 2)	Ψ_{JT}	10.0	7.0	°C/W

(Note 1) Based on JESD51-2A (Still-Air). The BD82A26MUF-M chip is used.

(Note 2) The thermal characterization parameter to report the difference between junction temperature and the temperature at the top center of the outside surface of the component package.

(Note 3) Using a PCB board based on JESD51-3.

(Note 4) Using a PCB board based on JESD51-5, 7.

Layer Number of Measurement Board	Material	Board Size
Single	FR-4	114.3 mm x 76.2 mm x 1.57 mm

Top	
Copper Pattern	Thickness
Footprints and Traces	70 μ m

Layer Number of Measurement Board	Material	Board Size	Thermal Via ^(Note 5)	
			Pitch	Diameter
4 Layers	FR-4	114.3 mm x 76.2 mm x 1.6 mm	1.20 mm	Φ 0.30 mm

Top		2 Internal Layers		Bottom	
Copper Pattern	Thickness	Copper Pattern	Thickness	Copper Pattern	Thickness
Footprints and Traces	70 μ m	74.2 mm x 74.2 mm	35 μ m	74.2 mm x 74.2 mm	70 μ m

(Note 5) This thermal via connect with the copper pattern of layers 1, 2, and 4. The placement and dimensions obey a land pattern.

Recommended Operating Conditions

Parameter	Symbol	Operating Range		Unit
		Min	Max	
Power Supply Voltage ^(Note 1)	VCC	3.0	48	V
DC/DC Oscillation Frequency Range	f _{OSC}	200	2420	kHz
PWM Frequency Range ^(Note 2)	f _{PWM}	0.1	25	kHz
External Synchronized Frequency Range ^(Note 3)	f _{SYNC}	Higher of 200 or f _{OSC} x 0.8	Lower of 2420 or f _{OSC}	kHz
External Synchronized Pulse Duty Range ^(Note 4)	f _{SDUTY}	40	60	%
LED Current Setting Range ^(Note 5)	I _{LED}	50	150	mA
Operating Temperature	T _{opr}	-40	+125	°C

(Note 1) When IC are started, VCC ≥ 5.0 V should be set.

VCC (Min) = 3.0 V is the minimum value of VCC that can operate the IC alone. The minimum value of power supply voltage that can be set varies depending on the connected LED load and external components.

(Note 2) Generally, flickering of LEDs is easier to see when the dimming frequency is set lower than 100 Hz. Check with the actual application evaluation.

(Note 3) When the external synchronization function is not used, connect the SYNC pin to the REG50 pin (SSCG = ON) or connect to the GND pin (SSCG = OFF) or OPEN (SSCG = OFF).

(Note 4) When using the external synchronous function, switching from the external synchronous state to the internal oscillation frequency is not possible during stable operation.

(Note 5) The amount of current per channel. Set the LED current so that the maximum junction temperature (T_{jmax}) is not exceeded.

Operating Conditions (External Constant Range)

Parameter	Symbol	Operating Range			Unit
		Min	Typ	Max	
REG25 Capacitance	C _{REG25}	0.10	0.22	0.47	μF
REG50 Capacitance	C _{REG50}	1.0	2.2	4.7	μF
LED Current Setting Resistor	R _{ISSET}	18.0	31.2	50.0	kΩ
Oscillation Frequency Setting Resistor	R _{RT}	4.0	33.3	45.0	kΩ
Input Capacitance 1	C _{VCC}	1 ^(Note 6)	-	-	μF
Input Capacitance 2	C _{INVCC} ^(Note 7)	10 ^(Note 6)	-	-	μF
Output Capacitance	C _{VOUT}	20 ^(Note 6)	-	100	μF
Charge Pump Capacitance 1	C _{CP1}	4.7	10.0	20.0	μF
Charge Pump Capacitance 2	C _{CP2}	1.0	2.2	4.7	μF
Resistor for the OVP Pin Setting (Low Side)	R _{OVP1}	10	-	20	kΩ
Resistor for the OVP Pin Setting (High Side)	R _{OVP2}	300	-	800	kΩ
Resistor for Unused Channels Setting (Low Side) ^(Note 8)	R _{LED1}	10	20	30	kΩ
Resistor for Unused Channels Setting (High Side) ^(Note 8)	R _{LED2}	40	100	180	kΩ

(Note 6) Set the capacitance so that it does not fall below the minimum value in consideration of temperature characteristics, DC bias characteristics, etc.

(Note 7) C_{INVCC} means the sum of C_{IN} and C_{VCC}. If a capacity of 10 μF or more is connected to C_{VCC}, the capacity of C_{IN} is not required.

(Note 8) The ratio of R_{LED1} to R_{LED2} should be between 1:4 and 1:6.

Electrical Characteristics

(Unless otherwise specified, VCC = 12 V, Ta = -40 °C to +125 °C)

Parameter	Symbol	Standard Value			Unit	Conditions
		Min	Typ	Max		
VCC Voltage at Startup	VCC_start	5.0	12.0	48.0	V	
Operating VCC Voltage ^(Note 1)	VCC_active	3.0	12.0	48.0	V	
Circuit Current	I _{CC}	-	-	20	mA	V _{EN} = 5 V, V _{SYNC} = 0 V, V _{PWM} = 0 V, C _{VCC} = 10 μF, R _{RT} = OPEN, R _{ISSET} = OPEN
Standby Current	I _{ST}	-	0	20	μA	V _{EN} = Low
[REGULATOR]						
Reference Voltage	V _{REG50}	4.5	5.0	5.5	V	I _{REG50} = 5 mA load, C _{REG50} = 2.2 μF
[DC/DC Converter]						
OUTL Pin High Side ON Resistor	R _{ONLH}	3.7	7.5	15.0	Ω	I _{OUTL} = 10 mA load
OUTL Pin Low Side ON Resistor	R _{ONLL}	1.2	2.5	5.0	Ω	I _{OUTL} = 10 mA input
LED Control Voltage 1	V _{LEDCTL1}	0.4	0.5	0.6	V	R _{ISSET} = 50 kΩ
LED Control Voltage 2	V _{LEDCTL2}	0.68	0.83	0.98	V	R _{ISSET} = 18 kΩ
COMP Sink Current	I _{COMPSINK}	170	250	330	μA	R _{ISSET} = 18 kΩ, V _{COMP} = 1.0 V, V _{LEDn} = 1.5 V (n = 1 to 6)
COMP Source Current	I _{COMPSOURCE}	-330	-250	-170	μA	R _{ISSET} = 18 kΩ, V _{COMP} = 1.0 V, V _{LEDn} = 0.0 V (n = 1 to 6)
Oscillation Frequency 1	f _{OSC1}	270	300	330	kHz	R _{RT} = 33.3 kΩ
Oscillation Frequency 2	f _{OSC2}	1980	2200	2420	kHz	R _{RT} = 4.0 kΩ
Max Duty ^{(Note 2)(Note 3)}	DUTY_MAX	96.5	98.0	-	%	R _{RT} = 33.3 kΩ
Switching OFF Time ^(Note 3)	t _{SWOFF}	-	67	130	ns	R _{RT} = 33.3 kΩ
[Charge Pump]						
Charge Pump Frequency	f _{CP}	250.0	312.5	375.0	kHz	C _{CP2} = 2.2 μF
Charge Pump Output Voltage	V _{CP}	4.5	5.0	5.5	V	C _{CP1} = 10 μF, C _{CP2} = 2.2 μF, V _{REG50} = 3.0 V

(Note 1) The minimum value of 3.0 V for VCC is the minimum value of VCC that can operate the IC alone. The minimum value of power supply voltage that can be set varies depending on the connected LED load and external components.

(Note 2) For the switching Duty required for applications, refer to the [2.13 Switching Duty Required for Applications](#).

(Note 3) Max Duty can be calculated using $(1-t_{SWOFF}) \times f_{OSC}$.

Electrical Characteristics – continued

(Unless otherwise specified, VCC = 12 V, Ta = -40 °C to +125 °C)

Parameter	Symbol	Standard Value			Unit	Conditions
		Min	Typ	Max		
[PROTECT]						
UVLO Release Voltage (VCC)	V _{UVLOVCC1}	3.00	3.20	3.40	V	VCC: Sweep up
UVLO Detect Voltage (VCC)	V _{UVLOVCC2}	2.65	2.80	2.95	V	VCC: Sweep down
UVLO Release Voltage (REG50)	V _{UVLOREG1}	2.90	3.10	3.30	V	V _{REG50} : Sweep up
UVLO Detect Voltage (REG50)	V _{UVLOREG2}	2.55	2.70	2.85	V	V _{REG50} : Sweep down
OCPL Detect Voltage	V _{OCPL}	0.27	0.30	0.33	V	V _{CSL} : Sweep up
Input OCP Detect Voltage	V _{OCPL}	0.17	0.20	0.23	V	VCC-V _{CSH} : Sweep down
LDSW Operation Voltage at Input OCP Release	V _{LDSW}	4.4	5.4	6.4	V	V _{CSH} = VCC VCC-V _{LDSW}
OVP Detect Voltage 1	V _{OVP1}	0.95	1.00	1.05	V	V _{OVP} = Sweep up
OVP Detect Voltage 1 Hysteresis Width	V _{OVP1HYS}	0.03	0.05	0.07	V	V _{OVP} = Sweep down
OVP Detect Voltage 2 (VDISC Pin)	V _{OVP2}	45	47	49	V	V _{DISC} = Sweep up
LED Open Protection Detect Voltage	V _{OPEN}	0.2	0.3	0.4	V	V _{LEDn} = Sweep down (n = 1 to 6), V _{OVP} > 2.0 V
LED Anode SCP Detect Voltage	V _{SCP1}	0.2	0.3	0.4	V	V _{OVP} = Sweep down
LED Cathode SCP Detect Voltage	V _{SCP2}	0.2	0.3	0.4	V	V _{LEDn} = Sweep down (n = 1 to 6)
LED Anode SCP Detect Delay Time	t _{SCP1}	10.5	13.1	15.7	ms	
LED Cathode SCP Detect Delay Time	t _{SCP2}	10.5	13.1	15.7	ms	
LED Short Protection Detect Voltage 1	V _{SHORT1}	4.2	4.5	4.8	V	SHT = GND, V _{LEDn} = Sweep up (n = 1 to 6)
LED Short Protection Detect Voltage 2	V _{SHORT2}	9	10	11	V	SHT = 1 V, V _{LEDn} = Sweep up (n = 1 to 6)
LED Short Protection Detect Delay Time	t _{SHORT}	10.5	13.1	15.7	ms	PWM = 100 % DIMSEL = GND
FAIL1 Pin ON Resistor	R _{FAIL1}	-	-	2.0	kΩ	
FAIL2 Pin ON Resistor	R _{FAIL2}	-	-	2.0	kΩ	

Electrical Characteristics – continued

(Unless otherwise specified, VCC = 12 V, Ta = -40 °C to +125 °C)

Parameter	Symbol	Standard Value			Unit	Conditions
		Min	Typ	Max		
[Current Driver]						
LED Current Absolute Variation 1	I_{LEDn} (Note 3)	76.0	80.0	84.0	mA	$R_{ISET} = 31.2 \text{ k}\Omega$, PWM = 100 % (Note 2)
LED Current Relative Variation 1 (Note 1)	I_{LEDREL}	0	-	3.0	%	$R_{ISET} = 31.2 \text{ k}\Omega$, PWM = 100 % (Note 2)
ISET-GND Short Protection Resistor	$R_{ISETLIM}$	-	1.0	-	k Ω	DIMSEL = GND
PWM Dimming Minimum Pulse Width	t_{PWMMIN}	0.5	-	-	μs	$f_{PWM} = 100 \text{ Hz to } 25 \text{ kHz}$, $I_{LEDn} = 50 \text{ mA to } 150 \text{ mA}$ (n = 1 to 6)
PWM Dimming Frequency	f_{PWM}	0.1	-	25.0	kHz	
Phase Delay Time	t_{PD}	-	10	-	μs	$V_{PD} = 5 \text{ V}$
PWM Low Section Detect Time	t_{PWML}	10.5	13.1	15.7	ms	
[PLSET Pin]						
No Additional Pulse Setting Voltage	V_{PLSET0}	GND	$V_{REG50} \times 0.10$	$V_{REG50} \times 0.15$	V	
Additional 2 Pulse Setting Voltage	V_{PLSET2}	$V_{REG50} \times 0.25$	$V_{REG50} \times 0.30$	$V_{REG50} \times 0.35$	V	
Additional 4 Pulse Setting Voltage	V_{PLSET4}	$V_{REG50} \times 0.45$	$V_{REG50} \times 0.50$	$V_{REG50} \times 0.55$	V	
Additional 8 Pulse Setting Voltage	V_{PLSET8}	$V_{REG50} \times 0.65$	$V_{REG50} \times 0.70$	$V_{REG50} \times 0.75$	V	
Additional 12 Pulse Setting Voltage	$V_{PLSET12}$	$V_{REG50} \times 0.85$	$V_{REG50} \times 0.90$	V_{REG50}	V	
PLSET Pin Inrush Current	I_{PLSET}	-1	0	+1	μA	
[DIMSEL Pin]						
Setting Voltage for PWM Dimming only	$V_{DIMSEL1}$	GND	$V_{REG50} \times 0.10$	$V_{REG50} \times 0.15$	V	
PWM-DC Switching 12.5 % Setting Voltage	$V_{DIMSEL2}$	$V_{REG50} \times 0.25$	$V_{REG50} \times 0.30$	$V_{REG50} \times 0.35$	V	
PWM-DC Switching 25 % Setting Voltage	$V_{DIMSEL3}$	$V_{REG50} \times 0.65$	$V_{REG50} \times 0.70$	$V_{REG50} \times 0.75$	V	
PWM-DC Switching 50 % Setting Voltage	$V_{DIMSEL4}$	$V_{REG50} \times 0.85$	$V_{REG50} \times 0.90$	V_{REG50}	V	
DIMSEL Pin Inrush Current	I_{DIMSEL}	-1	0	+1	μA	

(Note 1) $I_{LEDREL} = (\text{Maximum value of } I_{LED1} \text{ to } I_{LED6} - \text{Minimum value of } I_{LED1} \text{ to } I_{LED6}) / (\text{Maximum value of } I_{LED1} \text{ to } I_{LED6} + \text{Minimum value of } I_{LED1} \text{ to } I_{LED6}) \times 100$

(Note 2) When PWM Duty is lower than 100 %, it is larger than the variation described.

(Note 3) n = 1 to 6

Electrical Characteristics – continued

(Unless otherwise specified, VCC = 12 V, Ta = -40 °C to +125 °C)

Parameter	Symbol	Standard Value			Unit	Conditions
		Min	Typ	Max		
[EN Pin]						
Input High Voltage (EN)	V _{INH1}	2.3	-	-	V	
Input Low Voltage (EN)	V _{INL1}	-	-	0.5	V	
Input Resistor (EN)	R _{IN1}	50	100	150	kΩ	V _{EN} = 5 V
[PWM, SYNC Pin]						
Input High Voltage (PWM, SYNC)	V _{INH2}	2.3	-	-	V	
Input Low Voltage (PWM, SYNC)	V _{INL2}	-	-	0.5	V	
Input Resistor (PWM, SYNC)	R _{IN2}	50	100	150	kΩ	V _{PWM} = 5 V, V _{SYNC} = 5 V

Typical Performance Curves

(Reference data, unless otherwise specified VCC = 12 V)

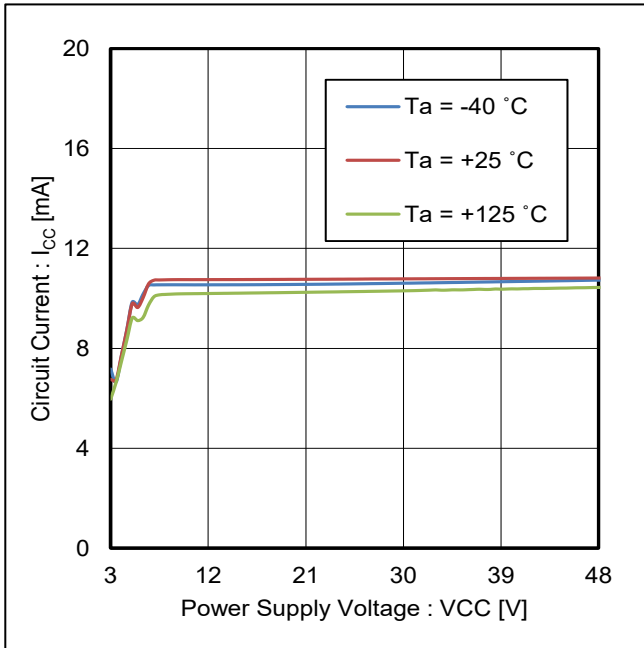

Figure 2. Circuit Current vs Power Supply Voltage

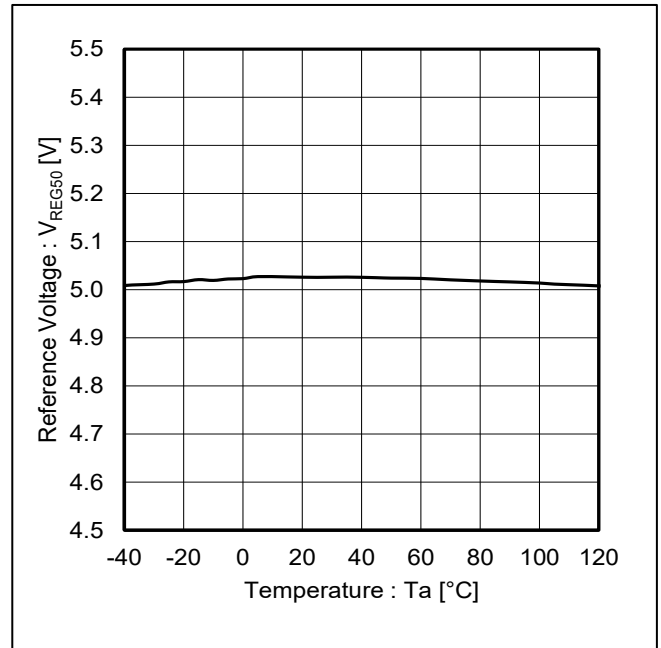

Figure 3. Reference Voltage vs Temperature

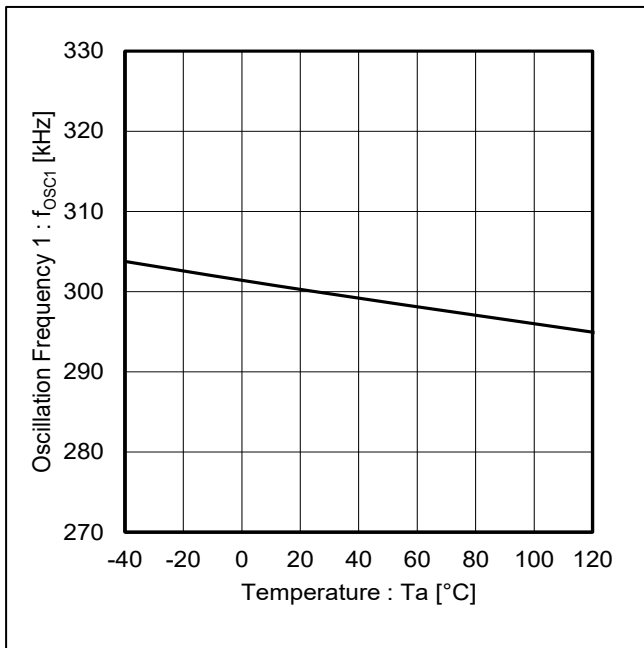

Figure 4. Oscillation Frequency 1 vs Temperature
(R_{RT} = 33.3 kΩ)

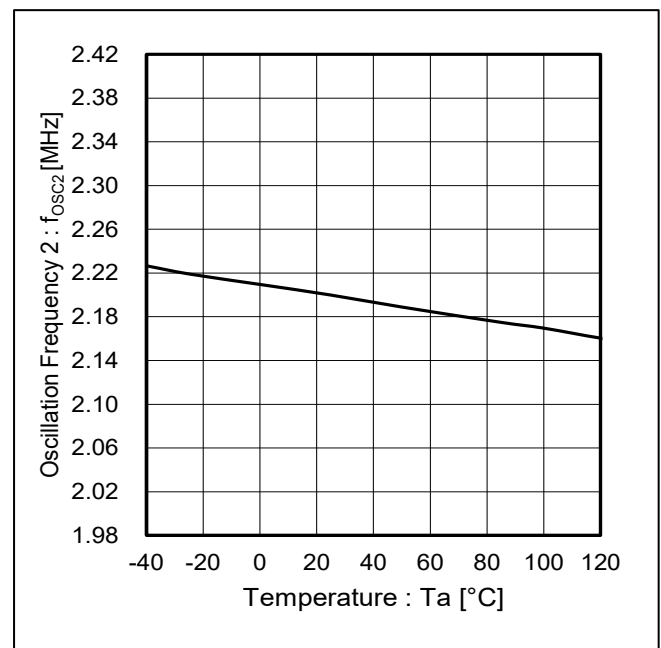

Figure 5. Oscillation Frequency 2 vs Temperature
(R_{RT} = 4.0 kΩ)

Typical Performance Curves – continued

(Reference data, unless otherwise specified VCC = 12 V)

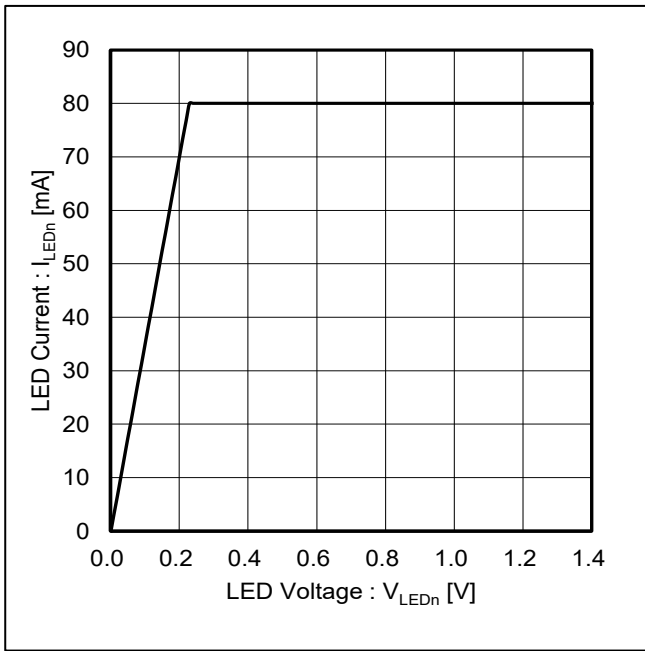

Figure 6. LED Current vs LED Voltage
($T_a = 25\text{ }^\circ\text{C}$, $R_{ISET} = 31.2\text{ k}\Omega$, $n = 1$ to 6)

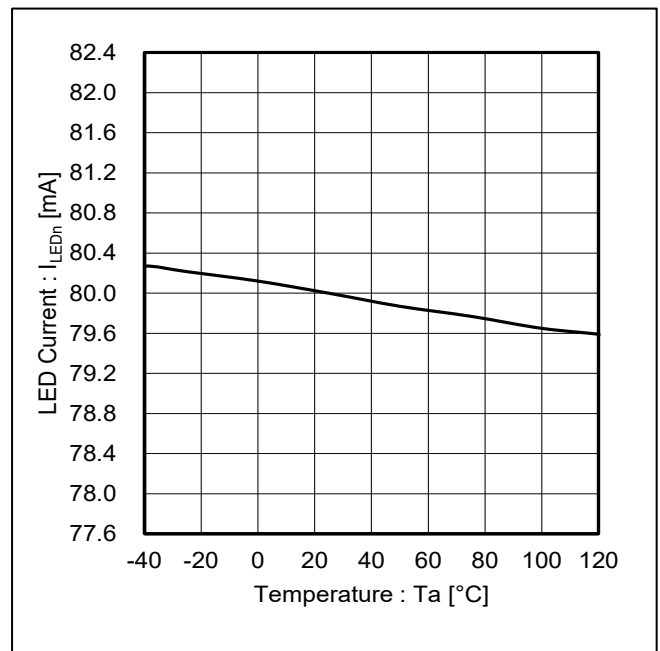

Figure 7. LED Current vs Temperature
($R_{ISET} = 31.2\text{ k}\Omega$, $n = 1$ to 6)

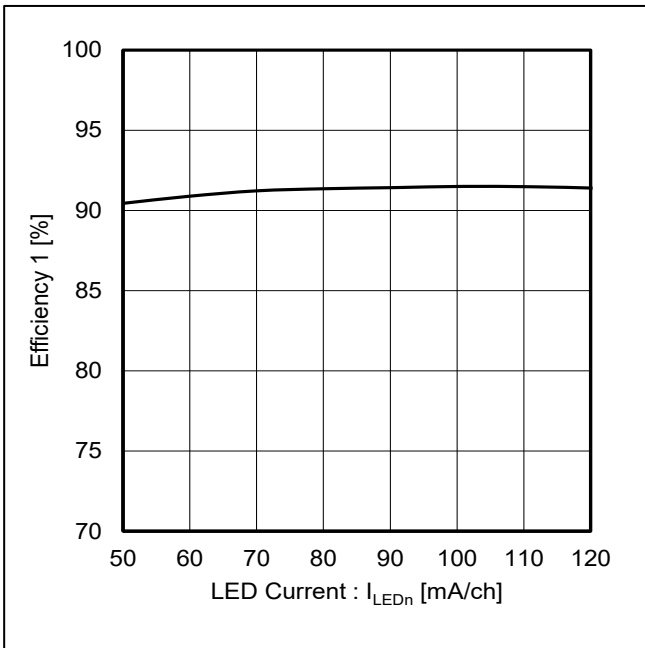

Figure 8. Efficiency 1 vs LED Current
($T_a = 25\text{ }^\circ\text{C}$, $R_{RT} = 33.3\text{ k}\Omega$, $n = 1$ to 6,
Number of LED Series = 12, Number of LED Parallel = 6)

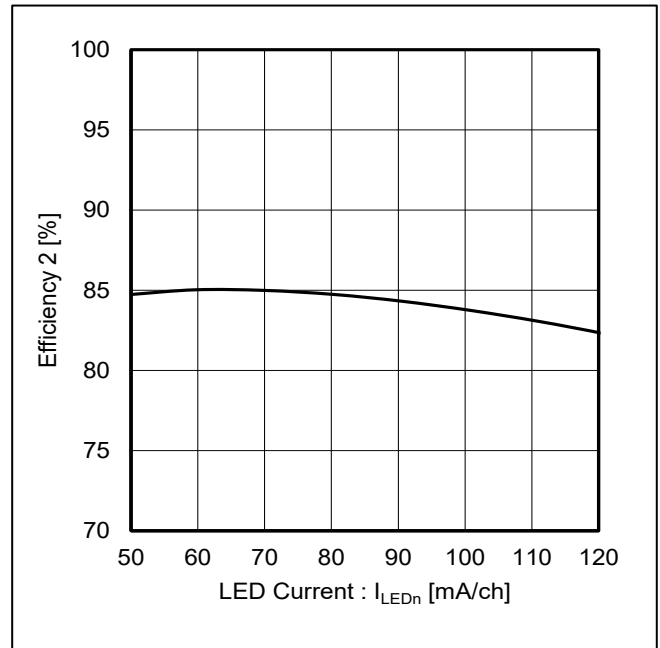

Figure 9. Efficiency 2 vs LED Current
($T_a = 25\text{ }^\circ\text{C}$, $R_{RT} = 4.0\text{ k}\Omega$, $n = 1$ to 6,
Number of LED Series = 12, Number of LED Parallel = 6)

Functional Descriptions

1 Current Driver

This model has a built-in 6ch current driver. The LED current setting range per channel is 50 mA to 138 mA, and the LED current can be adjusted by the resistance value between the ISET pin and GND.

[1.1 How to Set LED Current](#)

[1.2 Dimming Control of LED Current](#)

[1.2.1 When Using only PWM Dimming](#)

[1.2.2 When Switching Between PWM Dimming and DC Dimming Automatically](#)

[1.3 Phase Delay Function](#)

[1.4 LED Pin Handling of Unused Channels](#)

[1.5 PWM Low Section Detect Function](#)

[1.6 When Setting the LED Current Above 150 mA](#)

1.1 How to Set LED Current

The LED current I_{LED} can be calculated using the following equation.

$$I_{LED} = 2.5 \times 10^6 / R_{ISET} \quad [\text{mA}]$$

R_{ISET} represents the resistance value that is connected between the ISET pin and the GND pin. A resistor of 18 k Ω to 50 k Ω is recommended for R_{ISET} .

When $R_{ISET} \leq 1.0$ k Ω , ISET pin short protection is activated and the output of the LED current is stopped.

Resistance Setting Example

R_{ISET} [k Ω]	LED Current Value [mA]
50.0	50
31.2	80
25.0	100
20.8	120
18.0	138

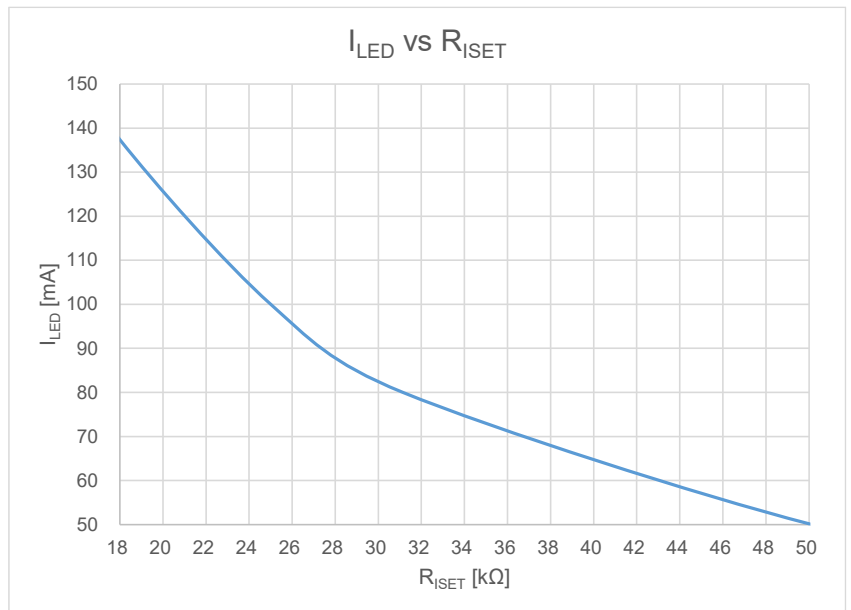

Figure 10. I_{LED} vs R_{ISET}

1 Current Driver – continued

1.2 Dimming Control of LED Current

The LED current can be controlled by On Duty of the pulse signal (input PWM signal) input to the PWM pin from the outside of the IC. Changing the input PWM frequency is prohibited because it may cause operation failure. When using [Phase Delay function](#) (PD = High) alternatively, [when using DC dimming](#), the input PWM signal is sampled synchronously with the IC Internal CLK = 20 MHz (Typ).

Sampling of Input PWM Signal (Synchronization with IC Internal CLK) or Not		
	Use Phase Delay Function	Do Not Use Phase Delay Function.
Use only PWM Dimming	Synchronized with IC Internal CLK	Without Synchronization
Use PWM Dimming and DC Dimming	Synchronized with IC Internal CLK	Synchronized with IC Internal CLK

To prevent flickering due to sampling, if the input PWM pulse width changes within ± 2 CLK of the IC Internal CLK, the change will not be reflected. In the example shown below, even if the input PWM width changes within the range of A, since the sampled input PWM signal changes within ± 2 CLK, the change is not reflected.

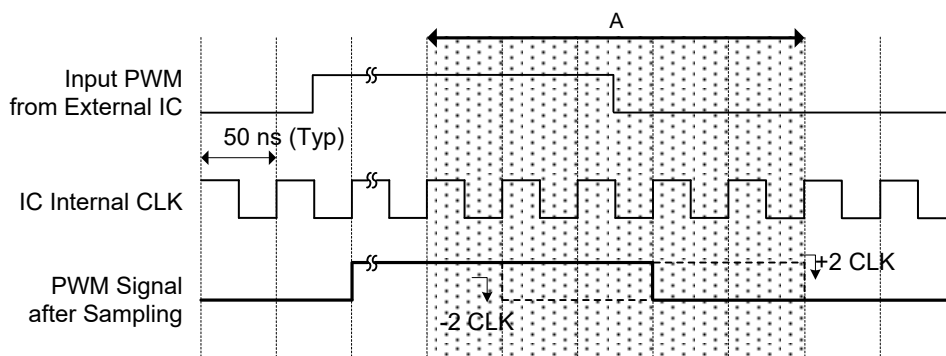

Figure 11. Section That Does Not Accept Changes in Input PWM Width

Also, if PWM = High is detected for twice the PWM period, the IC recognizes that PWM = 100 % is input, and the LED current is always ON.

The current dimming control can be selected from the following two methods.

1.2.1 When Using only PWM Dimming

When using only PWM dimming, short the DIMSEL pin with GND pin. The LED current can be controlled according to On Duty of the input PWM signal. However, in the area where the LED current ON time is less than 0.5 μ s or OFF time is less than 0.5 μ s, the pulse time is shorter than the PWM dimming minimum pulse width, so it cannot be used regularly. It is okay to use this area transiently, so it is also possible to set PWM Duty = 0 % and 100 %. The step width of the input PWM Duty should be 0.25 μ s or more. If the step width of the input PWM Duty is less than 0.25 μ s, the LEDs may flicker.

1.2 Dimming Control of LED Current – continued

1.2.2 When Switching Between PWM Dimming and DC Dimming Automatically

Dimming control can be performed by automatically switching between PWM dimming and DC dimming. The point for switching between PWM dimming and DC dimming is selected from three types: 50 %, 25 %, or 12.5 %. The point at which PWM dimming and DC dimming are switched can be set using DIMSEL pin voltages as shown in the table below. If the switching point for PWM-DC dimming is 12.5 %, Duty of the output LED current is 8 times the input PWM Duty, 4 times for 25 %, and 2 times for 50 %.

When the LED current ON time is less than 0.5 μs or the OFF time is less than 0.5 μs, the pulse time is shorter than the PWM dimming minimum pulse width, and therefore it cannot be used regularly. For example, if the switching point for PWM-DC dimming is 12.5 % and the PWM frequency is 200 Hz, the operation may become unstable if a PWM Duty within 625 μs ±0.5 μs (the range where the ON time of the LED current is less than 0.5 μs) is constantly input. There is no problem with using this area transiently.

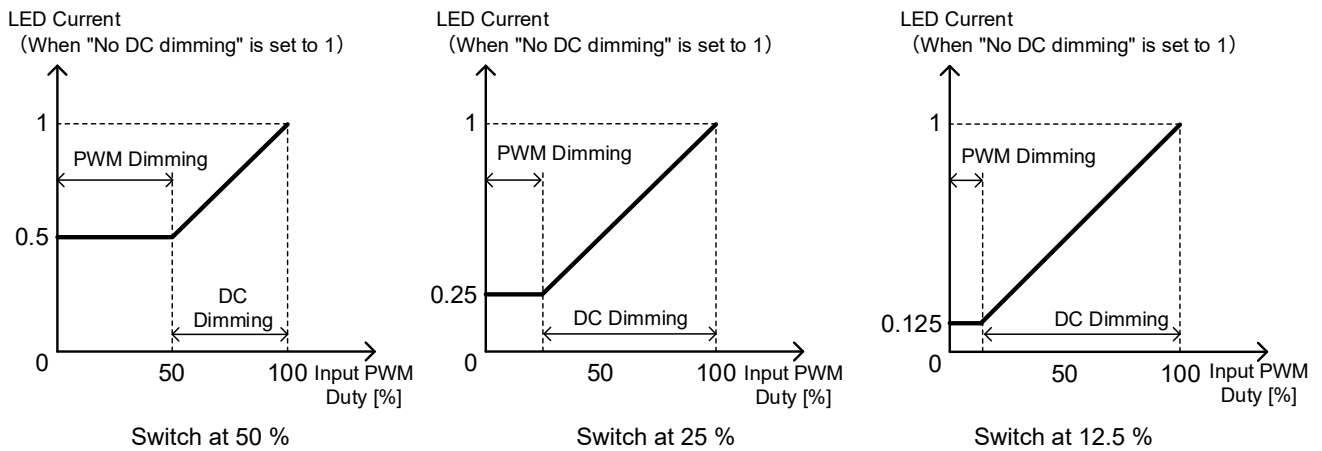
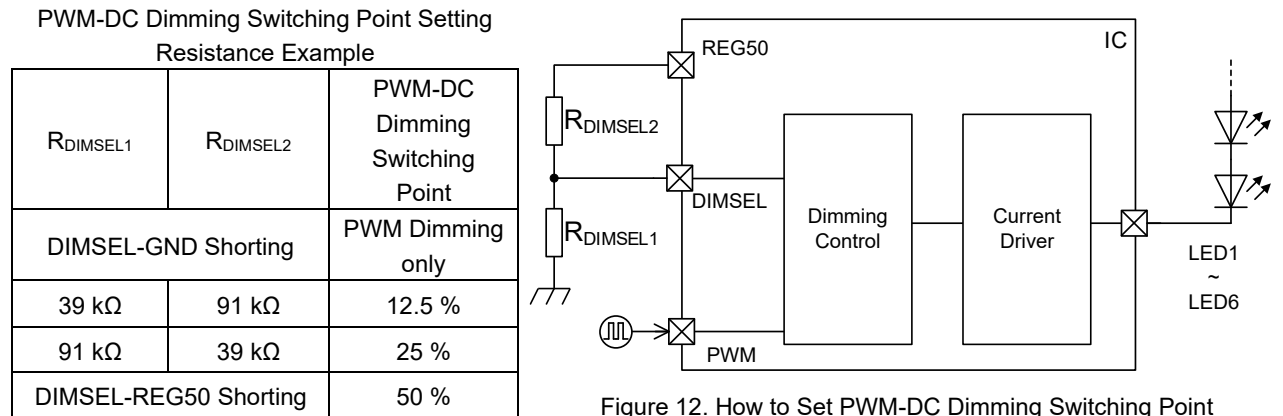

Figure 13. PWM-DC Dimming Switching Points 50 %, 25 %, and 12.5 %

1 Current Driver – continued

1.3 Phase Delay Function

This model has a built-in Phase Delay function that can shift the phase of the timing when LED1 to LED6 current during PWM dimming. The timing chart for Phase Delay is shown below. ($\Delta t = 10 \mu s$) When using Phase Delay function, short the PD pin to the REG50 pin. When not using Phase Delay function, connect the PD pin to the GND pin. Phase Delay function is available when the PWM frequency is 10 kHz or less.

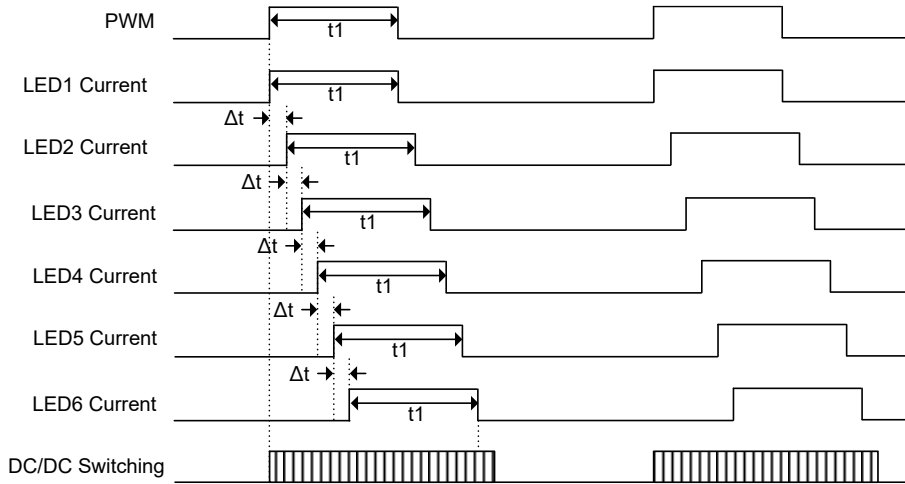

Figure 14. Phase Delay Operation

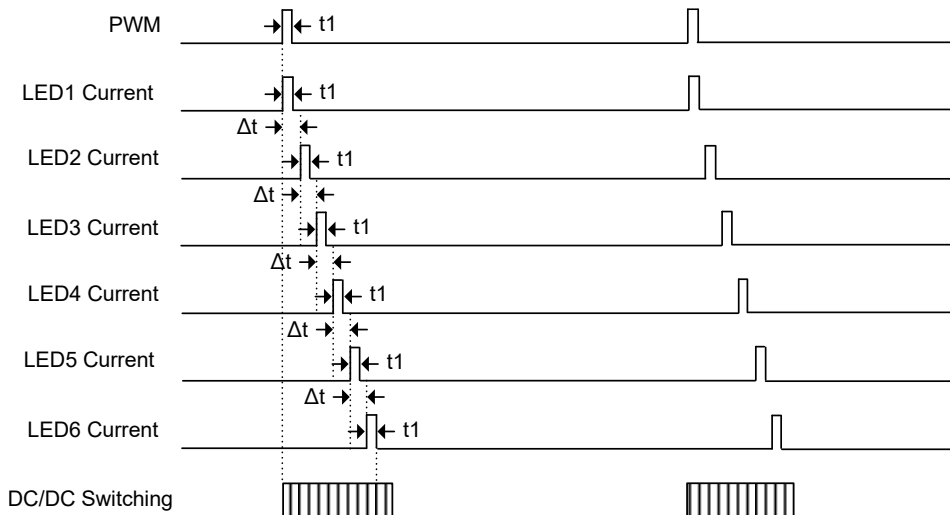

Figure 15. Phase Delay Operation for PWM Min Duty

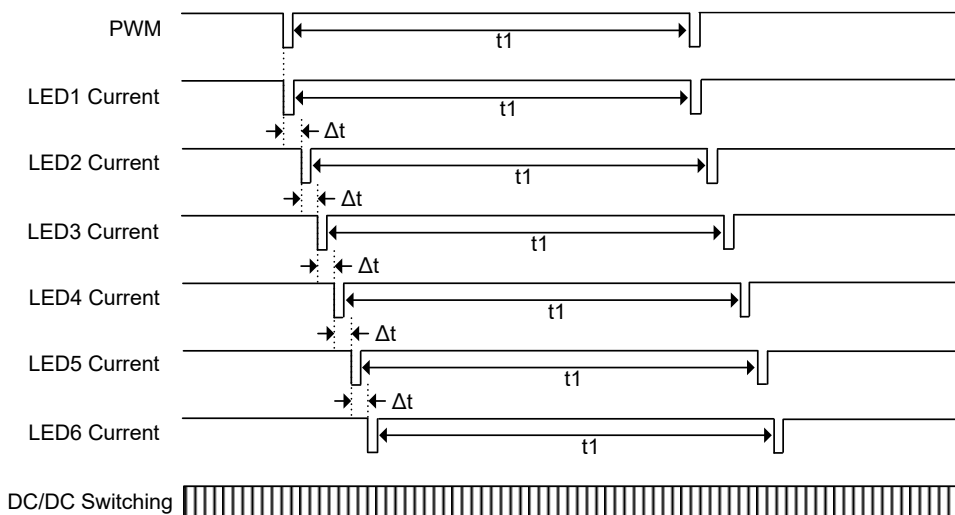

Figure 16. Phase Delay Operation for PWM Max Duty

1 Current Driver – continued

1.4 LED Pin Handling of Unused Channels

This model has six built-in constant current circuits. By setting the PWM pin to High, current can be supplied to the LED pin and LED current can be set by inserting a resistor between the ISET pin and the GND pin. The LED current setting that can be supplied per row is 50 mA to 150 mA. For unused channels, pull up the LED pin (LED1 to LED6) to REG50 with 100 kΩ and pull down to GND with 20 kΩ. To select unused channels definitely, the capacitance value to be connected to the LED pin should be 470 pF or less.

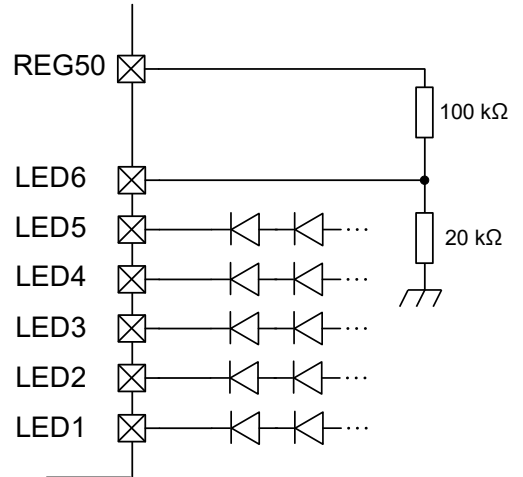

Figure 17. To Set LED6 to Unused

1.5 PWM Low Section Detect Function

The Low section of PWM input is counted in $V_{EN} = \text{High}$ status. When PWM Low section reaches 13.1 ms, operation is regarded as OFF state, and DC/DC output voltage is discharged from the VDISC pin. When the PWM input is turned High, switching operation is restarted.

1.6 When Setting the LED Current Above 150 mA

LED1 to LED6 pins can be used in bundles. For example, as shown in the figure on the right, if LED1, LED2, LED3, LED4, LED5, and LED6 are shorted, 6 times the current set by the ISET pin can be passed. To short each LED pin, short the PD pin to the GND pin. Please do not use a function for a Phase Delay. (For Phase Delay function, refer to "1.3 Phase Delay Function".)

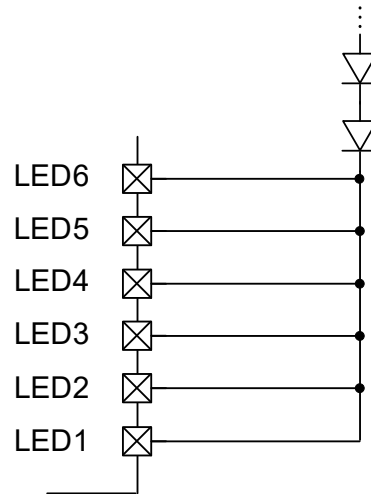

Figure 18. Application Example When the LED Pin Is Shorted

Functional Descriptions – continued

2 DC/DC Converters

Detects the lowest voltage among LED1 to LED6 pin voltages (LED cathode voltages) in Minimum Channel Selector block and inputs it to Error AMP. The reference voltage of Error AMP is generated in REF Voltage block based on R_{ISET} resistance value, which becomes LED pin control voltage. The output of Error AMP is compared with the output of SLOPE block by PWM COMP block. A switching signal is output to the OUTL pin through DC/DC Control LOGIC.

- [2.1 LED Pin Control Voltage V_{LEDCTL}](#)
- [2.2 VCC Input Voltage and Series Number of LED Elements](#)
- [2.3 LED Variation and Series Number](#)
- [2.4 Overvoltage Protection Function OVP](#)
- [2.5 DC/DC Converter Oscillation Frequency f_{osc}](#)
- [2.6 Setting the low side current detection resistor \(R_{C_{SL}}\)](#)
- [2.7 Setting the Coil Constant](#)
- [2.8 Setting the high side current detection resistor \(R_{C_{SH}}\)](#)

- [2.9 Additional Pulse Function](#)
- [2.10 External Synchronization / Spread Spectrum Function \(SSCG\)](#)
- [2.11 LSDET Function](#)
- [2.12 VOUT Discharge Function](#)
- [2.13 Switching Duty Required for Applications](#)
- [2.14 Fluctuation of LED current due to ripple voltage during PWM dimming](#)

2.1 LED Pin Control Voltage V_{LEDCTL}

The relation between LED pin control voltage (V_{LEDCTL}) and R_{ISET} resistance is shown in the table below.

Relation Between LED Pin Control Voltage (V_{LEDCTL}) and R_{ISET}

R _{ISET} [kΩ]	LED Pin Control Voltage V _{LEDCTL} [V]
50.0	0.50
31.2	0.50
25.0	0.60
20.8	0.72
18.0	0.83

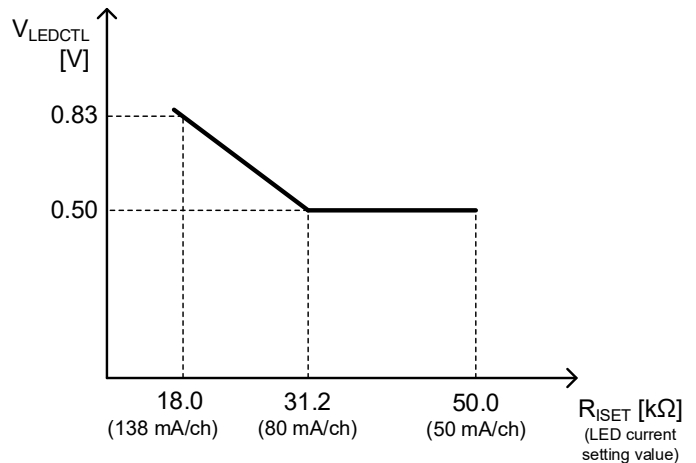

Figure 19. Relation Between LED Pin Control Voltage (V_{LEDCTL}) and R_{ISET}

2.2 VCC Input Voltage and Series Number of LED Elements

To drive the boost DC/DC converter, the LED elements must be selected so that the output voltage (V_{OUT}) is higher than the input voltage (V_{CC}).

$$V_{CC(MAX)} < V_{OUT(MIN)}$$

$$V_{CC(MAX)} < N \times V_{f(MIN)} + V_{LEDCTL(MIN)}$$

- V_{CC} : Input voltage
- V_{OUT}: DC/DC converter output voltage
- N : Number of LED series
- V_f : LED Vf voltage
- V_{LEDCTL}: LED control voltage

Select the number of LED series and Vf characteristics that satisfy the above equation.

2 DC/DC Converters – continued

2.3 LED Variation and Series Number

When operating multiple LED outputs, the LED anode voltages in each channel are commonly connected to DC/DC converter output VOUT. LED pin voltage (LED cathode voltage) in the channels where the Vf voltage of the LED is highest is lowest, and this is controlled to be V_{LEDCTL} . Therefore, other LED pin outputs have higher voltages by Vf variation. Select the number of LED series and Vf characteristics so that the LED short protection does not malfunction.

$$N \times (V_{f(MAX)} - V_{f(MIN)}) < V_{SHORT(MIN)} - V_{LEDCTL(MAX)} \quad V_{SHORT} : \text{LED short protection voltage}$$

LED short detection voltage can be set as shown in the table below depending on the voltage applied to the SHT pin.

Relationship between SHT pin voltage and LED short protection voltage

SHT pin voltage [V]	LED short protection voltage [V]
0	4.5
0.5	5.0
1.0	10
1.2	12

For example, a voltage can be applied to the SHT pin by dividing the resistance from the REG50 pin. When the SHT pin is connected to GND, the LED short detection threshold becomes 4.5 V. Please refer to [18.8 SHORT Det \(LED Short Detection\)](#) for details.

2.4 Overvoltage Protection Function OVP

Inputs the resistor division of the output voltage VOUT in the OVP pin.

When OVP pin voltage rises to 1.0 V or more, overvoltage protection is activated. Switching of DC/DC converter is turned OFF. After that, OVP is released when the OVP pin voltage drops to 0.95 V.

The setting range of R_{OVP1} is 10 kΩ to 20 kΩ, and it is recommended to set the OVP pin voltage within the range of 0.6 V to 0.8 V.

Also, the VOUT voltage during OVP detection should not exceed 45 V, which is the minimum value of overvoltage protection detect voltage 2 (VDISC pin).

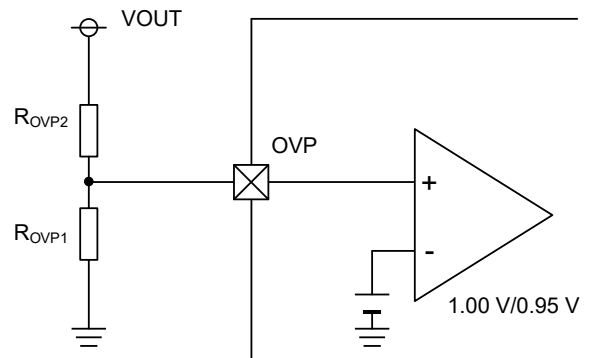

Figure 20. OVP Peripheral Circuit Diagram

OVP Pin Voltage Setting Sample

$$VOUT_{OVP} = \{(R_{OVP1} + R_{OVP2}) / R_{OVP1}\} \times 1.05 < 45 \quad [V]$$

$VOUT_{OVP}$: DC/DC converter output voltage (VOUT) during overvoltage protection operation

2 DC/DC Converters – continued

2.5 DC/DC Converter Oscillation Frequency f_{osc}

The oscillation frequency (f_{osc}) of DC/DC converter can be set by connecting a R_{RT} between the RT pin and the GND. The oscillation frequency of DC/DC converter is generated by the OSC-block. Set the resistor of R_{RT} referring to the data and theoretical formula below.

$$f_{osc} = (10^7 / R_{RT}) \times \alpha \quad [\text{kHz}]$$

- f_{osc} : Oscillation frequency of DC/DC converters
- 10^7 : Constants determined internally by the circuit
- R_{RT} : RT pin connecting resistor
- α : Correction factor

For the relation between f_{osc} and R_{RT} , refer to f_{osc} vs R_{RT} below. Note that operation cannot be guaranteed if f_{osc} setting value exceeds the recommended range of 200 kHz to 2420 kHz.

Example Resistance Value for f_{osc} Setting

R_{RT} [kΩ]	α
45.0	1.004
33.3	1.000
20.0	0.985
10.0	0.958
4.0	0.888

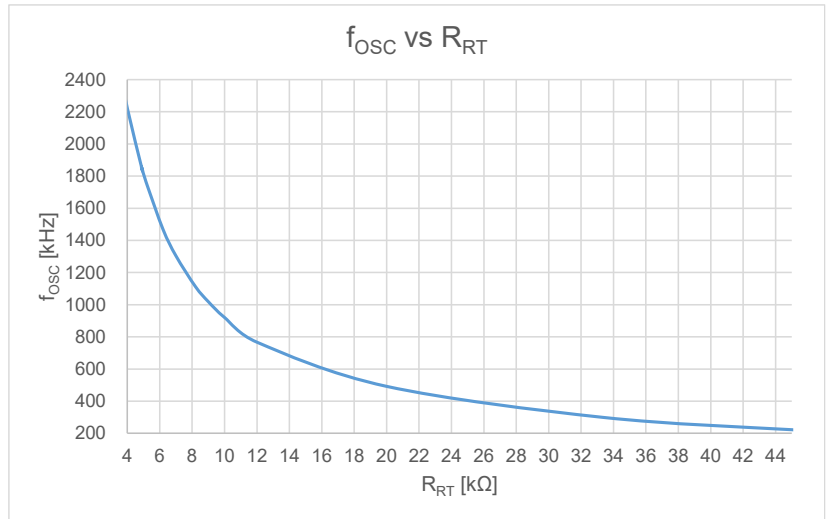

Figure 21. f_{osc} vs R_{RT}

2 DC/DC Converters – continued

2.6 Setting the low side current detection resistor (R_{CSL})

The low side current detection resistor (R_{CSL}) allows to set the overcurrent protection detection current. Set to satisfy the following formula.

$$I_{OCPL(MIN)} = V_{OCPL(MIN)} / R_{CSL} > I_{L(MAX)}$$

- $I_{OCPL(MIN)}$: Overcurrent protection detection current minimum value
- $V_{OCPL(MIN)}$: Overcurrent protection detection voltage minimum value (0.27 V)
- R_{CSL} : CSL pin connection resistance
- $I_{L(MAX)}$: Coil peak current maximum value

2.7 Setting the Coil Constant

To ensure stable operation of DC/DC converters, the following conditions are recommended for the coil inductance value.

$$R_{RT} \times R_{CSL} \times (V_{OUT(MAX)} - V_{CC(MIN)}) / L \leq 5.16 \times 10^9$$

- R_{RT} : RT pin connecting resistor
- R_{CSL} : CSL pin connecting resistor
- V_{OUT} : DC/DC converter output voltage
- V_{CC} : Input voltage
- L : Inductance value

Lowering the value on the left side increases stability, but decreases responsiveness.
Take the dispersion of inductance value into consideration and set it with sufficient margin.

2.8 Setting the high side current detection resistor (R_{CSH})

The high side current detection resistor (R_{CSH}) allows to set the input overcurrent protection detection current. Set to satisfy the following formula.

$$I_{OCPH(MIN)} = V_{OCPH(MIN)} / R_{CSH} > I_{OCPL(MAX)} = V_{OCPL(MAX)} / R_{CSL}$$

- $I_{OCPH(MIN)}$: Input overcurrent protection detection current minimum value
- $V_{OCPH(MIN)}$: Input overcurrent protection detection voltage minimum value (0.17 V)
- R_{CSH} : CSH pin connection resistance
- $I_{OCPL(MAX)}$: Overcurrent protection detection current maximum value
- $V_{OCPL(MAX)}$: Overcurrent protection detection voltage maximum value (0.33 V)
- R_{CSL} : CSL pin connection resistance

2 DC/DC Converters – continued

2.9 Additional Pulse Function

A pulse addition function is provided to output a stable DC/DC converter output voltage and LED current even when PWM Duty is low. The output voltage can be held by outputting additional switching of several pulses after the falling edge of the PWM input signal, and the LED can be turned on normally.

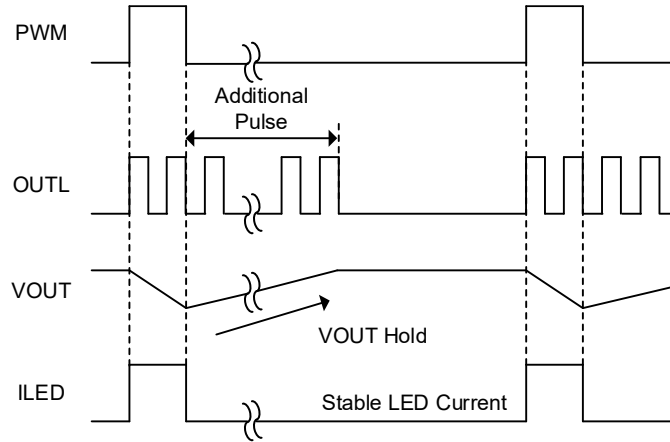

Figure 22. Pulse Addition Function

The number of switching pulses to be added is set by the resistance value connected to the PLSET pin. As shown in the figure below, it can connect R_{PLSET1} , R_{PLSET2} and set the number of switching pulses to be added by the resistance ratio. Examples of resistance values are shown in the table below.

Example of Resistance Value
When Setting Additional Pulse Number

R_{PLSET1}	R_{PLSET2}	Number of Additional Pulses
PLSET-GND Shorting		0 Pulse
39 k Ω	91 k Ω	2 Pulses
100 k Ω	100 k Ω	4 Pulses
91 k Ω	39 k Ω	8 Pulses
PLSET-REG50 Shorting		12 Pulses

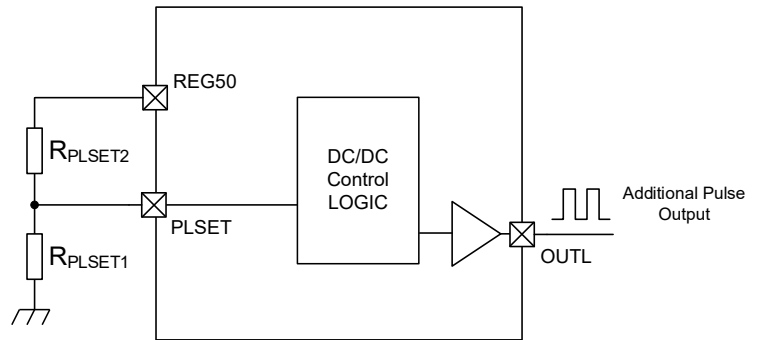

Figure 23. Additional Pulse Number Setting Method

The setting of the number of switching pulses to be added is performed immediately after the EN pin voltage is turned on and prior to starting. It is not possible to change the setting of the number of switching pulses to be added after startup.

2 DC/DC Converters – continued

2.10 External Synchronization / Spread Spectrum Function (SSCG)

Three switching modes can be selected according to the voltage input to the SYNC pin. The input to the SYNC pin must precede the input to the EN pin.

Mode	V _{SYNC}	DC/DC Switching Frequency
1	GND or OPEN	Fixed Frequency Mode Determined by R _{RT}
2	V _{REG50}	Spread Spectrum Mode of the Frequency Determined by R _{RT}
3	Pulse Input	Mode to Synchronize with the Frequency Input to the SYNC Pin

Mode 1: When the SYNC pin is GND or OPEN, the DC/DC converter switches at [a fixed frequency determined by the R_{RT}](#).

Mode 2: By shorting the SYNC pin and the REG50 pin, operation in spread spectrum mode (SSCG) is enabled. Noise peaks can be reduced by periodically changing the oscillation frequency by SSCG. The fluctuation range of the frequency due to SSCG is -8 % of the set oscillation frequency from the set oscillation frequency. The oscillation frequency fluctuation cycle (t_{SSCG}) is 128 / set oscillation frequency. Note that operating SSCG may change noise levels other than the oscillation frequency.

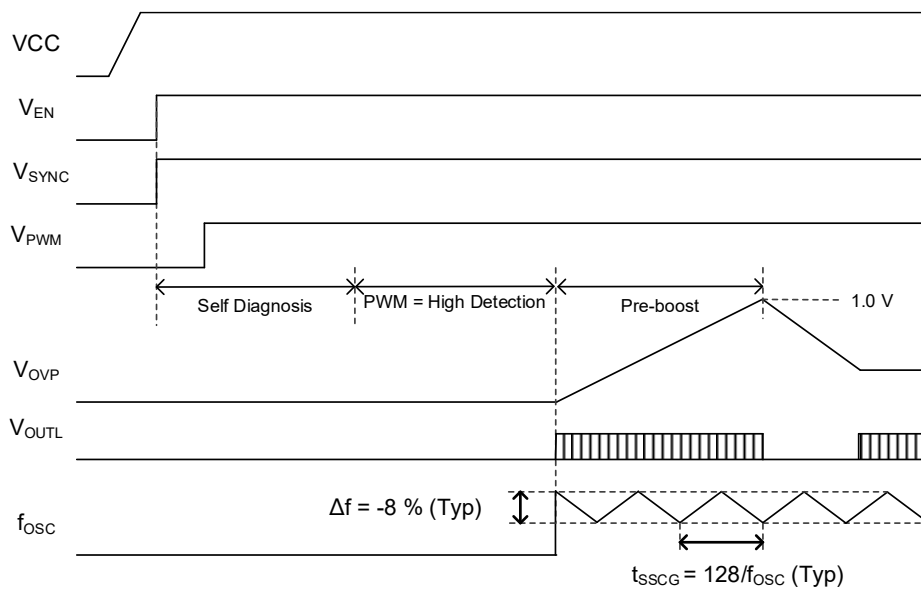

Figure 24. Spread Spectrum Function Timing Chart

$$\Delta f = f_{osc} \times 0.08$$

$$t_{SSCG} = \frac{128}{f_{osc}}$$

Δf : Fluctuation range of the oscillation frequency by SSCG
 f_{osc} : DC/DC oscillation frequency
 t_{SSCG} : Modulating period of the oscillation frequency by SSCG

The amount of noise reduction during SSCG S [dB] can be roughly estimated by the following equation.

$$\begin{aligned}
 S &= -10 \times \log \frac{1}{\Delta f \times t_{SSCG}} \quad [\text{dB}] \\
 &= -10 \times \log \frac{f_{osc}/128}{f_{osc} \times 0.08} \quad [\text{dB}] \\
 &= 10 \quad [\text{dB}]
 \end{aligned}$$

When not using SSCG function, short the SYNC pin and the GND pin. SSCG function cannot be turned ON/OFF during operation.

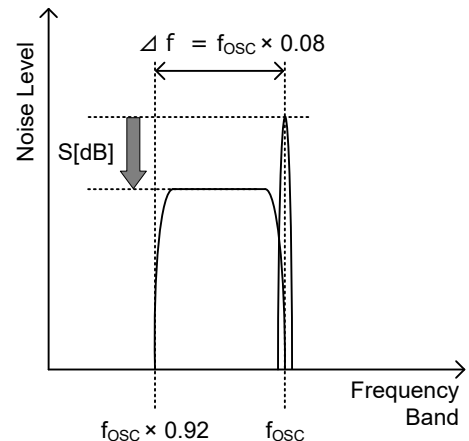

Figure 25. Spread Spectrum Function

2.10 External Synchronization / Spread Spectrum Function (SSCG) – continued

Mode 3: By inputting an external clock signal to the SYNC pin, the internal oscillation frequency can be externally synchronized. Input the clock signal to SYNC pin before the Self Diagnosis is completed. (For Self Diagnosis, refer to "[3 Startup Characteristics and Effective Section of Each Protection Function](#)")

Internal oscillation and external synchronization cannot be switched on the way. Operation may become unstable. When using external synchronization, SSCG cannot be used.

2.11 LSDET Function

When the lowest LED pin voltage among the LED pins exceeds 1.5 V (Typ), the DC/DC converter is turned OFF and the COMP voltage is held.

DC/DC converter resumes switching when the lowest LED pin voltage drops $V_{LEDCTL} \times 1.1$ or less.

LSDET function is intended to reduce the voltage quickly when the output is over boosted. It also prevents the LEDs from flickering by restarting the switching of DC/DC converters just before returning to normal operation. LSDET function is enabled only when Duty of the LED current is ON. The following is an example when LED6 becomes open.

- ① The LED6 pin is open and LED6 pin voltage is 0.3 V (Typ) or less. (A)
DC/DC converter output begins to boost LED6 pin voltage further. In conjunction with this, OVP pin voltage also rises. (B)
- ② When OVP pin voltage reaches 1.0 V (C) due to the boost of DC/DC converter, the LED open protection is activated. When the LED open protection is activated, the LED6 pin that was open is pulled up to REG50 pin voltage V_{REG50} inside the IC. (D)
LSDET function operates because LED6 pin voltage, which is the lowest LED pin voltage among the LED pins, exceeds 1.5 V (Typ). (D)
LSDET function turns OFF DC/DC converters and holds COMP voltage. (E)
- ③ DC/DC converter turns OFF, the output voltage drops, and OVP pin voltage also drops. (F)
- ④ When the lowest LED pin voltage is $V_{LEDCTL} \times 1.1$ (Typ) or less (G) the DC/DC converters resume switching. (H)

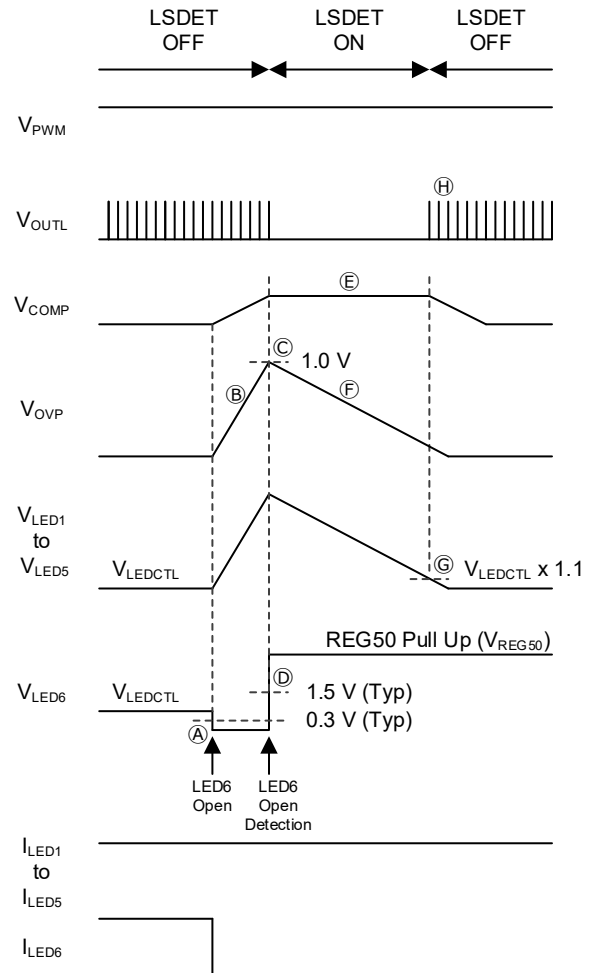

Figure 26. LSDET Function When LEDs Are Open

2.12 VOUT Discharge Function

The LEDs may flicker if activated with charges remaining on VOUT. Therefore, discharging of VOUT is required at startup. However, discharging of the charge may take a long time only by the discharge path such as the resistor for OVP setting. Therefore, an output voltage discharging circuit (VOUT discharge function) is provided in this model. When DC/DC circuit is OFF (when EN pin voltage falls or PWM Low section is detected), residual charges in the output are discharged. The discharge time t_{DISC} is expressed by the following equation.

$$t_{DISC} = 3 \times C_{OUT} \times V_{OUT} \quad [s]$$

2 DC/DC converters – continued

2.13 Switching Duty Required for Applications

As an application of DC/DC converters, the switching duty required for stable operation can be roughly estimated by the following equations.

$$SWDUTY = (V_{OUT} + V_{fD1} - VCC) / (V_{OUT} + V_{fD1} - VD_{M2})$$

- SWDUTY : Required switching Duty
- V_{OUT} : DC/DC converter output voltage
- V_{fD1} : Vf voltage of the boosting diode (D1)
- VCC : Input voltage
- VD_{M2} : Drain voltage when FET (M2) for boosting is ON

The above values are approximate values. The switching Duty actually required depends on the characteristics and operating conditions of the application components. Finally, check the actual operation.

2.14 Fluctuation of LED current due to ripple voltage during PWM dimming

During PWM dimming, the LED current does not flow and the LED pin voltage (V_{LED}) becomes high in the PWM = Low section, and the V_{LED} is controlled by the V_{LEDCTL} in the PWM = High section. Depending on the settings of external components such as the LED current setting and the capacity of the output capacitor, the V_{LED} may undershoot at the start of PWM. Due to this undershoot, the LED current may drop momentarily as shown in the figure below. When the LED current setting value of each CH is 65 mA or more, it is recommended that the undershoot amount (ΔV_{drop}) of V_{LED} at PWM = High is 50 mV or less. However, even if the LED current drops momentarily due to undershoot, the LED may not appear to flicker. Be sure to evaluate on the actual board and check from a visual point of view.

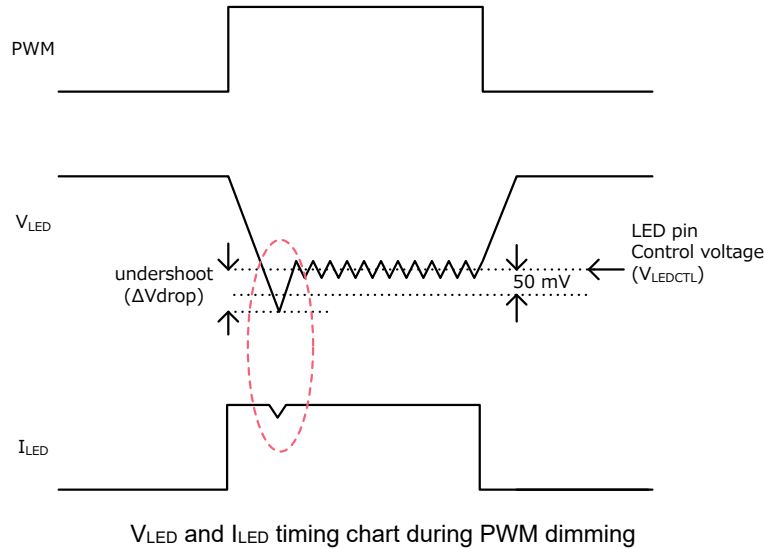

Functional Descriptions - continued

3 Startup Characteristics and Effective Section of Each Protection Function

3.1 When PWM Duty Is 100 %

The timing chart at startup and the effective section of each protection function are shown in the figure below.

- ① Power ON: Input EN voltage after the VCC voltage is input.
- ② Self Diagnosis: Determines the channels to be used, determines whether or not to use Phase Delay, sets the number of additional pulses, and sets PWM/DC dimming, etc. Self Diagnosis is completed after 13.1 ms (Typ), and the diagnostic status is latched.
- ③ PWM signal detection: When PWM = High has elapsed 13.1 ms, it recognizes that PWM = 100 % and begins the startup.
- ④ Pre-boost^(Note 1): Outputs switching until the OVP pin voltage reaches 1.0 V and boosting is performed.
- ⑤ Stable operation transition section: DC/DC switching is turned OFF. The output voltage of DC/DC converter drops according to the LED current.
- ⑥ Stable state: When LED voltage (the lowest voltage in LED1 to LED6) drops to LED control voltage x 1.1, DC/DC converter switches again.

(Note 1) Because a higher switching Duty is required than stable state, Pre-boost may not be completed depending on operating conditions and component conditions. Contact us for details.

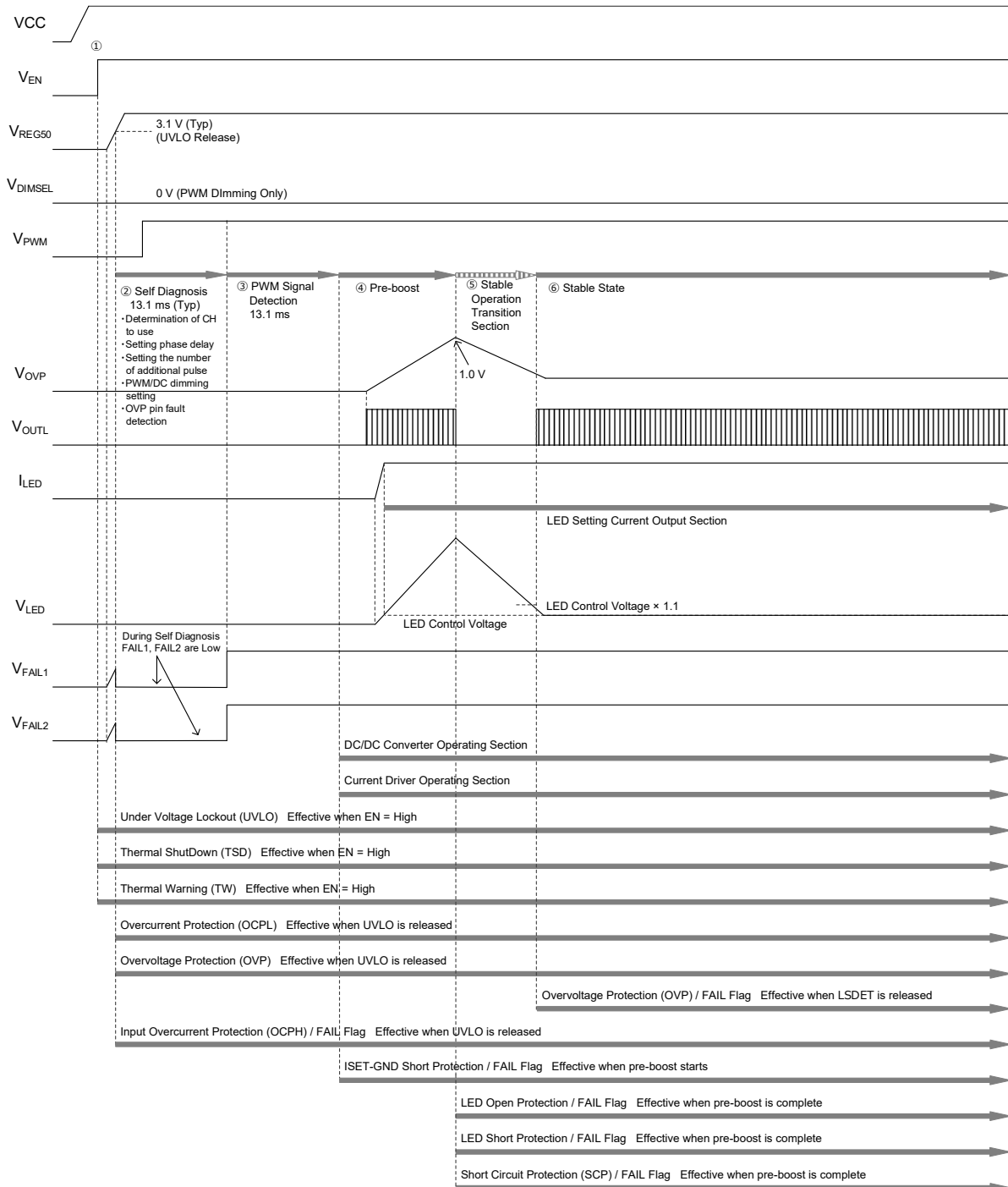

3 Startup Characteristics and Effective Section of Each Protection Function – continued

3.2 When Using only PWM Dimming

The timing chart at startup and the effective section of each protection function when only PWM dimming is used are shown in the figure below.

- ① Power ON: Input EN voltage after the VCC voltage is input.
- ② Self Diagnosis: Determines the channels to be used, determines whether or not to use Phase Delay, sets the number of additional pulses, and sets PWM/DC dimming, etc. Self Diagnosis is completed after 13.1 ms (Typ), and the diagnostic status is latched.
- ③ PWM signal detection: Begins the startup at the first rising edge of PWM.
- ④ Pre-boost^(Note 1): Regardless of On Duty of PWM, switching is output until OVP pin voltage reaches 1.0 V, and boosting is performed.
- ⑤ Stable operation transition section: DC/DC switching is turned OFF. The output voltage of DC/DC converter drops according to the LED current.
- ⑥ Stable state: When LED voltage (the lowest voltage in LED1 to LED6) drops to LED control voltage x 1.1, DC/DC converter switches again.

(Note 1) Because a higher switching Duty is required than stable state, Pre-boost may not be completed depending on operating conditions and component conditions. Contact us for details.

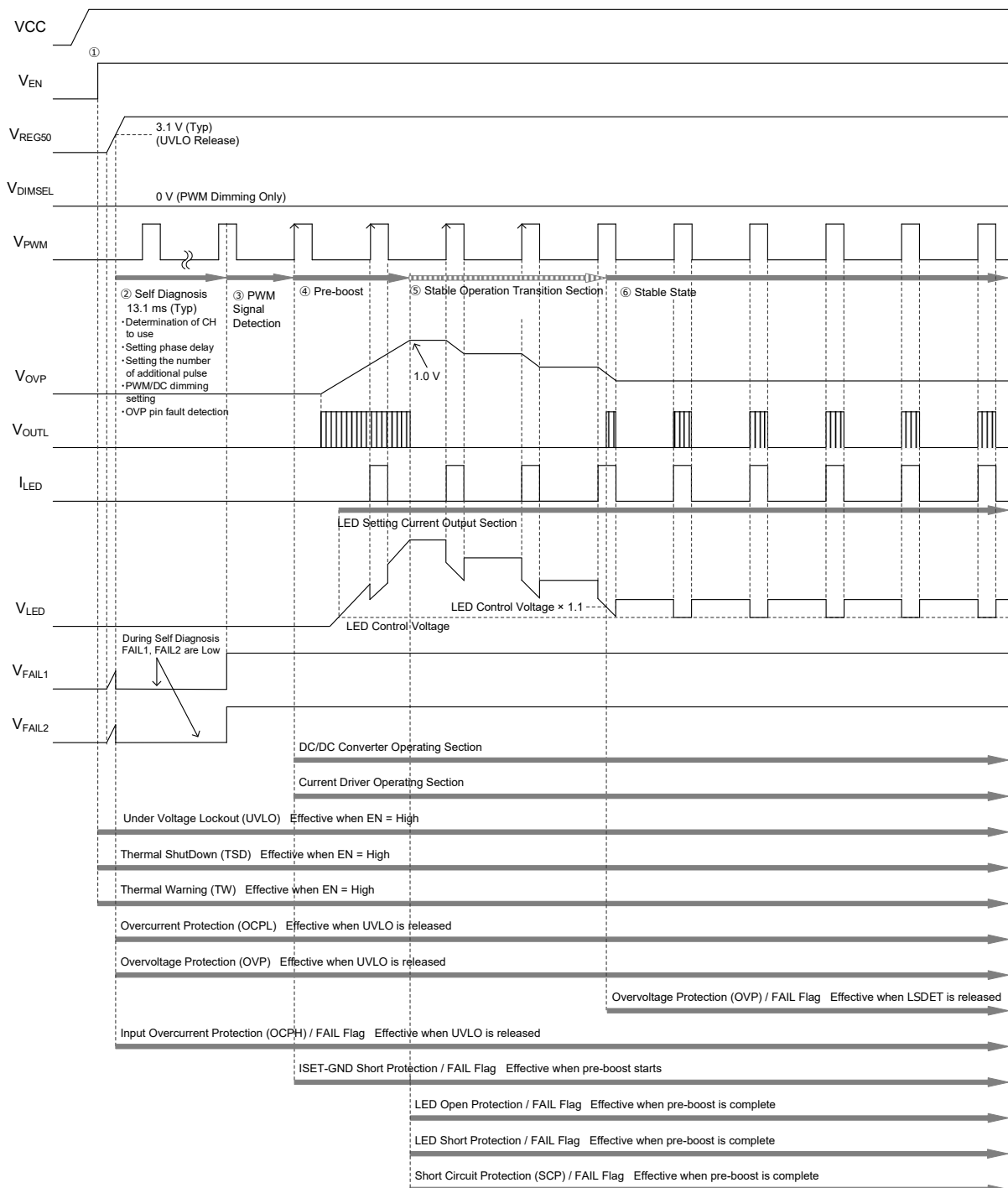

3 Startup Characteristics and Effective Section of Each Protection Function – continued

3.3 When Switching Between PWM Dimming and DC Dimming

The timing chart at startup and the effective section of each protection function when switching between PWM dimming and DC dimming are shown in the figure below.

- ① Power ON: Input EN voltage after the VCC voltage is input.
- ② Self Diagnosis: Determines the channels to be used, determines whether or not to use Phase Delay, sets the number of additional pulses, and sets PWM/DC dimming, etc. Self Diagnosis is completed after 13.1 ms (Typ), and the diagnostic status is latched.
- ③ PWM signal detection: Begins the startup at the fourth rising edge of PWM after Self Diagnosis.
- ④ Pre-boost^(Note 1): Regardless of On Duty of PWM, switching is output until OVP pin voltage reaches 1.0 V, and boosting is performed.
- ⑤ Stable operation transition section: DC/DC switching is turned OFF. The output voltage of DC/DC converter drops according to the LED current.
- ⑥ Stable state: When LED voltage (the lowest voltage in LED1 to LED6) drops to LED control voltage x 1.1, DC/DC converter switches again.

(Note 1) Because a higher switching Duty is required than stable state, Pre-boost may not be completed depending on operating conditions and component conditions. Contact us for details.

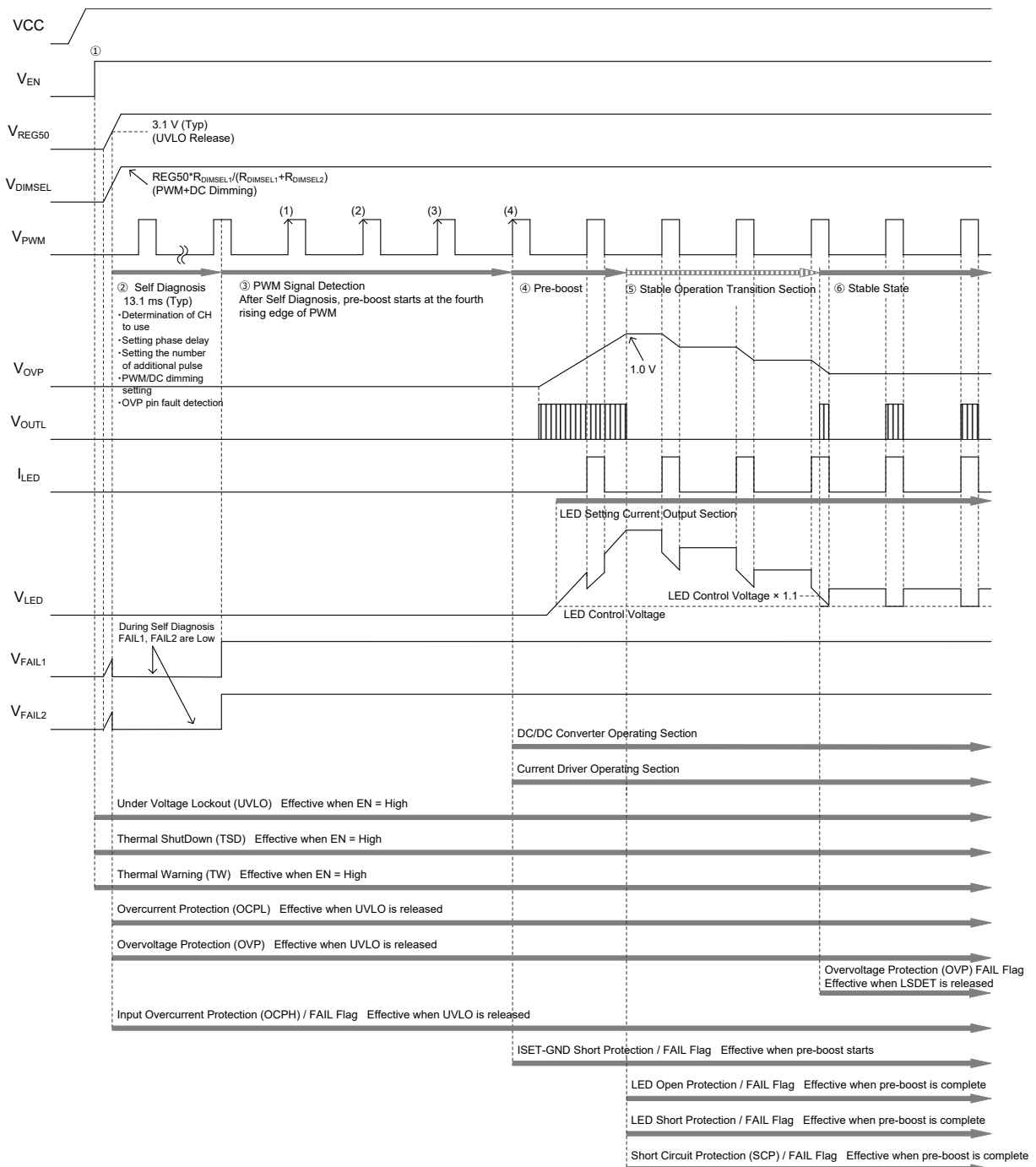

3 Startup Characteristics and Effective Section of Each Protection Function – continued

3.4 Timing Chart When Stopped (When Pulling Up FAIL1 and FAIL2 to REG50)

The figure below shows the timing chart when stopped (EN = Low) when FAIL1 and FAIL2 are pulled up to REG50.

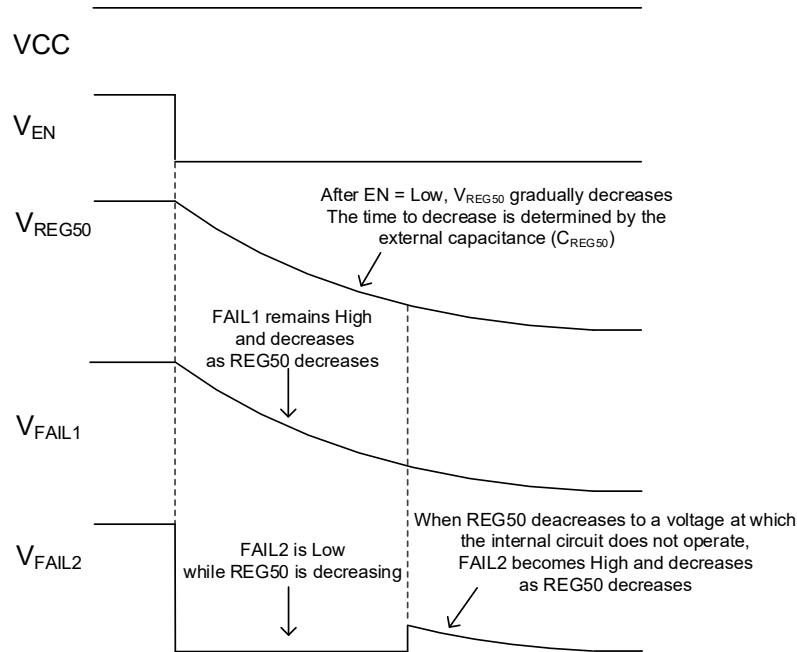

After V_{EN} = Low, the V_{REG50} will gradually decrease. The time to decrease depends on the value of the capacitance (C_{REG50}) connected to REG50. Immediately after V_{EN} = Low, the operation inside the IC is turned OFF and V_{FAIL1} = High and V_{FAIL2} = Low are output. V_{FAIL1} decreases as V_{REG50} decreases because it is pulled up to V_{REG50}. While the V_{REG50} is still high enough, V_{FAIL2} = Low will continue to be output, but when V_{REG50} decreases to a level where Low of V_{FAIL2} cannot be output, V_{FAIL2} = High. After that, V_{FAIL2} decreases as V_{REG50} decreases

3.5 Timing Chart When Stopped (When Pulling Up FAIL1 and FAIL2 to an External Power Supply)

The figure below shows the timing chart when stopped (EN = Low) when FAIL1 and FAIL2 are pulled up to an external power supply.

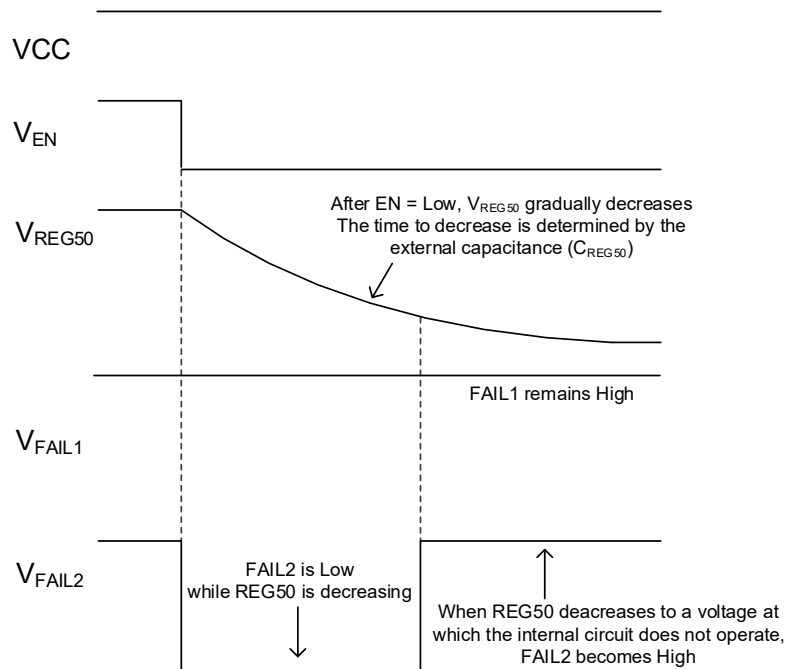

After V_{EN} = Low, the V_{REG50} will gradually decrease. The time to decrease depends on the value of the capacitance (C_{REG50}) connected to REG50. Immediately after V_{EN} = Low, the operation inside the IC is turned OFF and V_{FAIL1} = High and V_{FAIL2} = Low are output. V_{FAIL1} holds the High voltage because it is pulled up to an external power supply. While the V_{REG50} is still high enough, V_{FAIL2} = Low will continue to be output, but when V_{REG50} decreases to a level where Low of V_{FAIL2} cannot be output, V_{FAIL2} = High.

List of External Components

Serial No.	Component Name	Component Value	Product Name	Manufacturer
1	CB1	-	-	-
2	CB2	-	-	-
3	L1	-	-	-
4	CVCC1	-	-	-
5	CVCC2	-	-	-
6	CVCC3	0.1 μ F	GCM155R71H104KE37	murata
7	REN1	-	-	-
8	REN2	-	-	-
9	RCSH	39 m Ω	LTR18 Series	Rohm
10	M1	-	RD3L140SPFRA	Rohm
11	CIN1	10 μ F	GCM32EC71H106KA03	murata
12	CIN2	-	-	-
13	L2	10 μ H	CLF10060NIT-100M-D	TDK
14	M2	-	RD3L080SNFRA	Rohm
15	RCSL	68 m Ω	LTR18 Series	Rohm
16	D1	-	RB088LAM-60TF	Rohm
17	COU1	0.01 μ F	GCM155R71H103KA55	murata
18	COU2	0.1 μ F	GCM155R71H104KE02	murata
19	COU3	-	-	-
20	COU4	-	-	-
21	COU5	22 μ F	GYA1H220MCQ1GS	nichicon
22	CREG25	0.22 μ F	GCM155R71C224KE02	murata
23	CREG50	2.2 μ F	GCM188C71A225KE01	murata
24	RRT	33 k Ω	MCR01 Series	Rohm
25	RPLSET1	100 k Ω	MCR01 Series	Rohm
26	RPLSET2	100 k Ω	MCR01 Series	Rohm
27	RPC	51 Ω	MCR01 Series	Rohm
28	CPC1	1 μ F	GCM188R71C105KA49	murata
29	CPC2	-	-	-
30	RISSET	33 k Ω	MCR01 Series	Rohm
31	RDIMSEL1	SHORT	-	-
32	RDIMSEL2	OPEN	-	-
33	CLED1D	470pF	GCM155R11H471KA01	murata
34	CLED2D	470pF	GCM155R11H471KA01	murata
35	CLED3D	470pF	GCM155R11H471KA01	murata
36	CLED4D	470pF	GCM155R11H471KA01	murata
37	CLED5D	470pF	GCM155R11H471KA01	murata
38	CLED6D	470pF	GCM155R11H471KA01	murata

List of External Components – continued

Serial No.	Component Name	Component Value	Product Name	Manufacturer
39	CLED1U	-	-	-
40	CLED2U	-	-	-
41	CLED3U	-	-	-
42	CLED4U	-	-	-
43	CLED5U	-	-	-
44	CLED6U	-	-	-
45	RCS	Short	-	-
46	CCS	-	-	-
47	RG	10 Ω	MCR01 Series	Rohm
48	JP_PD1	Short	-	-
49	JP_PD2	-	-	-
50	JP_SHT	Short	-	-
51	RFAIL2	100 k Ω	MCR01 Series	Rohm
52	ROVP1	10 k Ω	MCR01 Series	Rohm
53	ROVP2	360 k Ω	MCR01 Series	Rohm
54	COVP	-	-	-
55	RFAIL1	100 k Ω	MCR01 Series	Rohm
56	C _{CP1}	10 μ F	GCM32EC71H106KA03	murata
57	C _{CP2}	2.2 μ F	GCM188C71A225KE01	murata
58	R _{SNB1}	-	-	-
59	C _{SNB1}	-	-	-
60	R _{SNB2}	-	-	-
61	C _{SNB2}	-	-	-

Note: The component constants vary depending on the operating conditions and the load used.

Power Consumption Calculation Example

$$P_C = I_{CC} \times V_{CC} \quad (1) \text{ Circuit power}$$

$$+ C_{ISS1} \times V_{REG50} \times f_{OSC} \times V_{REG50} \quad (2) \text{ Low side FET drive stage power}$$

$$+ \{V_{LED} \times M + \Delta V_f \times (M - 1)\} \times I_{LED} \quad (3) \text{ Current driver power}$$

P_C : IC power consumption
 I_{CC} : Circuit current
 V_{CC} : Power supply voltage
 C_{ISS1} : Low side FET gate capacitance
 V_{REG50} : REG50 Voltage
 f_{OSC} : Oscillation Frequency
 V_{LED} : LED control voltage
 M : Number of LED Parallels
 ΔV_f : LED Vf variation per row
 I_{LED} : LED output current

<Calculation Example>

Assuming $I_{CC} = 10 \text{ mA}$, $V_{CC} = 12 \text{ V}$, $C_{ISS1} = 2000 \text{ pF}$, $V_{REG50} = 5 \text{ V}$, $f_{OSC} = 2200 \text{ kHz}$, $V_{LED} = 0.83 \text{ V}$, $I_{LED} = 150 \text{ mA}$, $M = 6$ columns and $\Delta V_f = 0.2 \text{ V}$,

$$P_C = 10 \text{ mA} \times 12 \text{ V} + 2000 \text{ pF} \times 5 \text{ V} \times 2200 \text{ kHz} \times 5 \text{ V} + \{0.83 \text{ V} \times 6ch + 0.2 \text{ V} \times (6ch - 1)\} \times 150 \text{ mA} = 1.127 \quad [\text{W}]$$

From thermal resistance $\theta_{ja} = 30.7 \text{ }^\circ\text{C/W}$, the maximum calorific value Δt_{MAX} can be estimated by the following equation.

$$\Delta t_{MAX} = P_C \times \theta_{ja} = 1.127 \text{ W} \times 30.7 = 34.6 \quad [^\circ\text{C}]$$

When the ambient temperature is $85 \text{ }^\circ\text{C}$, the maximum chip temperature $t_{C_{MAX}}$ is:

$$t_{C_{MAX}} = 85 \text{ }^\circ\text{C} + 34.6 \text{ }^\circ\text{C} = 119.6 \quad [^\circ\text{C}]$$

Make sure that $t_{C_{MAX}}$ calculated here is less than $T_{jmax} = 150 \text{ }^\circ\text{C}$.

The above is a simple calculation example only. The value of thermal resistance varies depending on the actual board conditions and layout. Please check it as a guide for thermal design.

I/O Equivalence Circuit

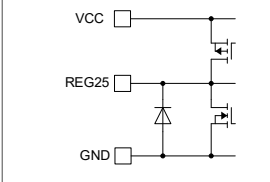
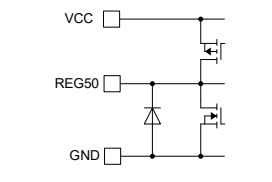
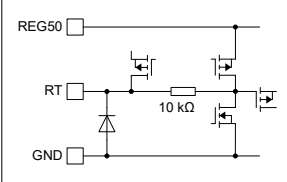
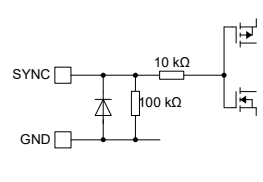
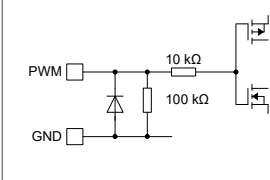
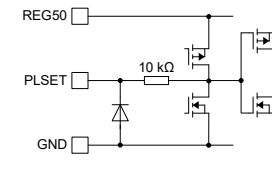
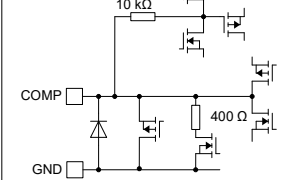
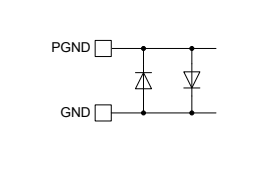
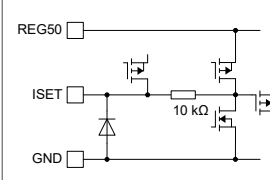
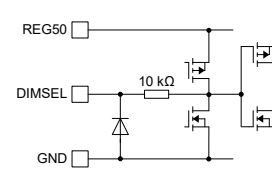
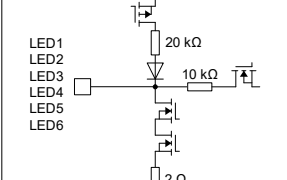
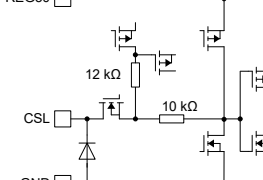
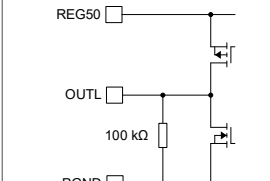
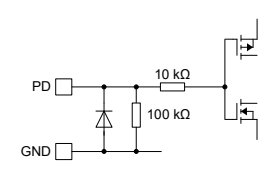
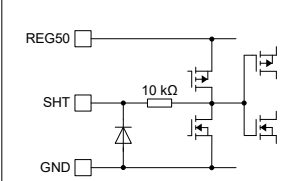
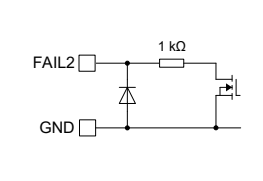
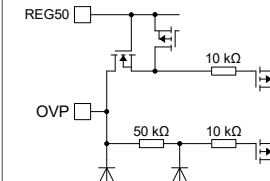
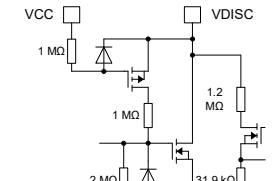
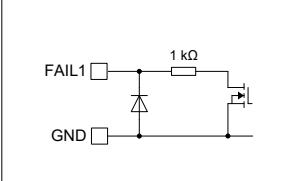
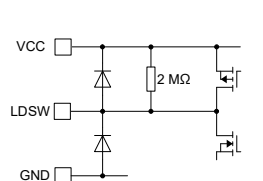
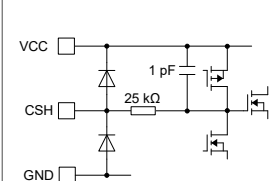
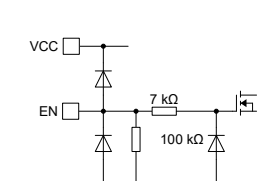
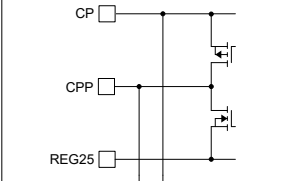
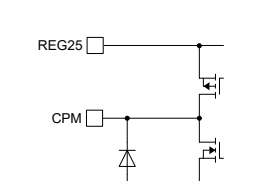
<p>1.REG25</p> 	<p>2.REG50</p> 	<p>3.RT</p> 	<p>4.SYNC</p> 
<p>5.PWM</p> 	<p>6.PLSET</p> 	<p>7.COMP</p> 	<p>8.GND, 19.PGND</p> 
<p>9.ISET</p> 	<p>10.DIMSEL</p> 	<p>11 - 16.LED1 - LED6</p> 	<p>17.CSL</p> 
<p>18.OUTL</p> 	<p>20.PD</p> 	<p>21.SHT</p> 	<p>22.FAIL2</p> 
<p>23.OVP</p> 	<p>24.VDISC</p> 	<p>25.FAIL1</p> 	<p>26.LDSW</p> 
<p>27.CSH</p> 	<p>29.EN</p> 	<p>30.CP, 31.CPP</p> 	<p>32.CPM</p> 

Note: All values are Typ values.

Operational Notes

1. Reverse Connection of Power Supply

Connecting the power supply in reverse polarity can damage the IC. Take precautions against reverse polarity when connecting the power supply, such as mounting an external diode between the power supply and the IC's power supply pins.

2. Power Supply Lines

Design the PCB layout pattern to provide low impedance supply lines. Furthermore, connect a capacitor to ground at all power supply pins. Consider the effect of temperature and aging on the capacitance value when using electrolytic capacitors.

3. Ground Voltage

Ensure that no pins are at a voltage below that of the ground pin at any time, even during transient condition.

4. Ground Wiring Pattern

When using both small-signal and large-current ground traces, the two ground traces should be routed separately but connected to a single ground at the reference point of the application board to avoid fluctuations in the small-signal ground caused by large currents. Also ensure that the ground traces of external components do not cause variations on the ground voltage. The ground lines must be as short and thick as possible to reduce line impedance.

5. Recommended Operating Conditions

The function and operation of the IC are guaranteed within the range specified by the recommended operating conditions. The characteristic values are guaranteed only under the conditions of each item specified by the electrical characteristics.

6. Inrush Current

When power is first supplied to the IC, it is possible that the internal logic may be unstable and inrush current may flow instantaneously due to the internal powering sequence and delays, especially if the IC has more than one power supply. Therefore, give special consideration to power coupling capacitance, power wiring, width of ground wiring, and routing of connections.

7. Testing on Application Boards

When testing the IC on an application board, connecting a capacitor directly to a low-impedance output pin may subject the IC to stress. Always discharge capacitors completely after each process or step. The IC's power supply should always be turned off completely before connecting or removing it from the test setup during the inspection process. To prevent damage from static discharge, ground the IC during assembly and use similar precautions during transport and storage.

8. Inter-pin Short and Mounting Errors

Ensure that the direction and position are correct when mounting the IC on the PCB. Incorrect mounting may result in damaging the IC. Avoid nearby pins being shorted to each other especially to ground, power supply and output pin. Inter-pin shorts could be due to many reasons such as metal particles, water droplets (in very humid environment) and unintentional solder bridge deposited in between pins during assembly to name a few.

9. Unused Input Pins

Input pins of an IC are often connected to the gate of a MOS transistor. The gate has extremely high impedance and extremely low capacitance. If left unconnected, the electric field from the outside can easily charge it. The small charge acquired in this way is enough to produce a significant effect on the conduction through the transistor and cause unexpected operation of the IC. So unless otherwise specified, unused input pins should be connected to the power supply or ground line.

Operational Notes – continued

10. Regarding the Input Pin of the IC

This monolithic IC contains P+ isolation and P substrate layers between adjacent elements in order to keep them isolated. P-N junctions are formed at the intersection of the P layers with the N layers of other elements, creating a parasitic diode or transistor. For example (refer to figure below):

When $GND > Pin A$ and $GND > Pin B$, the P-N junction operates as a parasitic diode.

When $GND > Pin B$, the P-N junction operates as a parasitic transistor.

Parasitic diodes inevitably occur in the structure of the IC. The operation of parasitic diodes can result in mutual interference among circuits, operational faults, or physical damage. Therefore, conditions that cause these diodes to operate, such as applying a voltage lower than the GND voltage to an input pin (and thus to the P substrate) should be avoided.

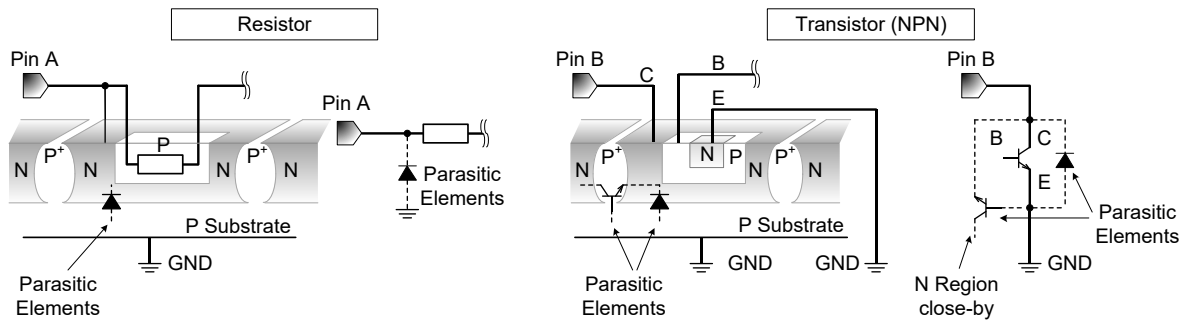

Figure 27. Example of Monolithic IC Structure

11. Ceramic Capacitor

When using a ceramic capacitor, determine a capacitance value considering the change of capacitance with temperature and the decrease in nominal capacitance due to DC bias and others.

12. Thermal Shutdown Circuit (TSD)

This IC has a built-in thermal shutdown circuit that prevents heat damage to the IC. Normal operation should always be within the IC's maximum junction temperature rating. If however the rating is exceeded for a continued period, the junction temperature (T_j) will rise which will activate the TSD circuit that will turn OFF power output pins. When the T_j falls below the TSD threshold, the circuits are automatically restored to normal operation.

Note that the TSD circuit operates in a situation that exceeds the absolute maximum ratings and therefore, under no circumstances, should the TSD circuit be used in a set design or for any purpose other than protecting the IC from heat damage.

13. Over Current Protection Circuit (OCP)

This IC incorporates an integrated overcurrent protection circuit that is activated when the load is shorted. This protection circuit is effective in preventing damage due to sudden and unexpected incidents. However, the IC should not be used in applications characterized by continuous operation or transitioning of the protection circuit.

14. Functional Safety

"ISO 26262 Process Compliant to Support ASIL-***"

A product that has been developed based on an ISO 26262 design process compliant to the ASIL level described in the datasheet.

"Safety Mechanism is Implemented to Support Functional Safety (ASIL-*)"

A product that has implemented safety mechanism to meet ASIL level requirements described in the datasheet.

"Functional Safety Supportive Automotive Products"

A product that has been developed for automotive use and is capable of supporting safety analysis with regard to the functional safety.

Note: "ASIL-***" is stands for the ratings of "ASIL-A", "-B", "-C" or "-D" specified by each product's datasheet.

Ordering Information

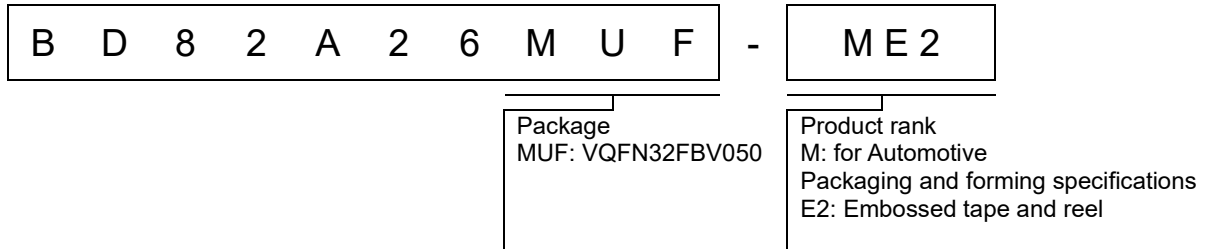

Marking Diagram

VQFN32FBV050 (TOP VIEW)

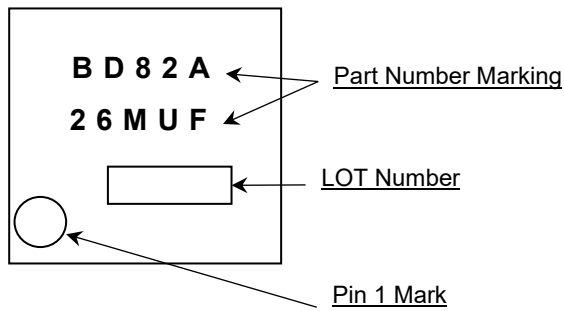

Physical Dimension and Packing Information

Package Name	VQFN32FBV050
--------------	--------------

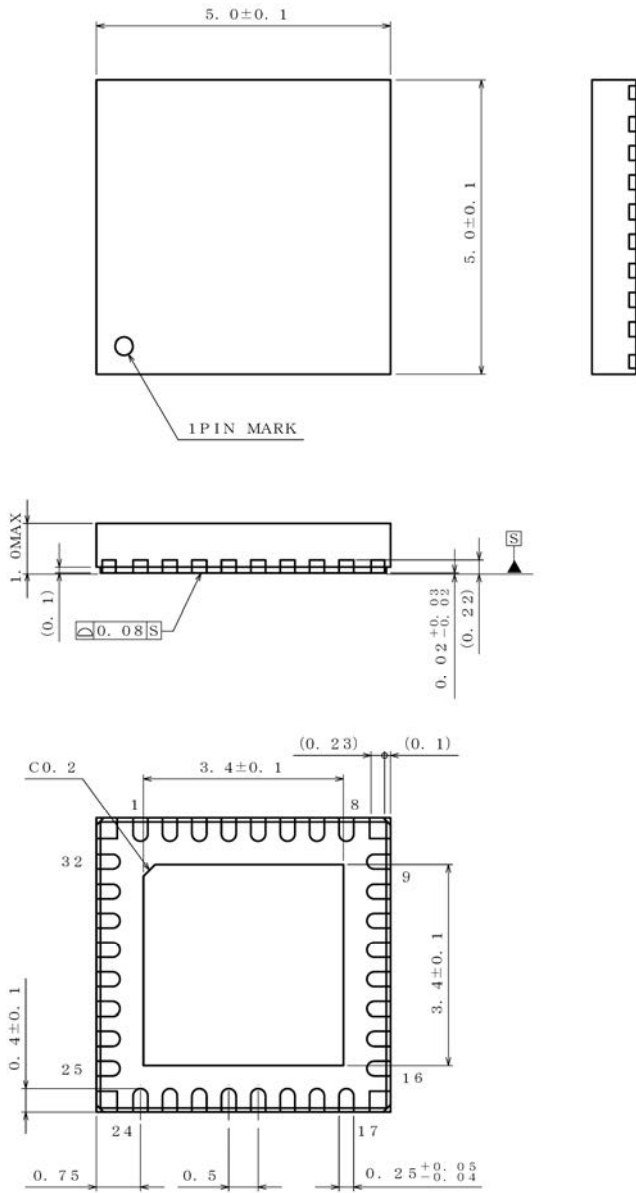

(UNIT : mm)

PKG : VQFN32FBV050
Drawing No. EX416-5001

NOTE: Dimensions in () for reference only.

< Tape and Reel Information >

Tape	Embossed carrier tape
Quantity	2500pcs
Direction of feed	E2 The direction is the pin 1 of product is at the upper left when you hold reel on the left hand and you pull out the tape on the right hand

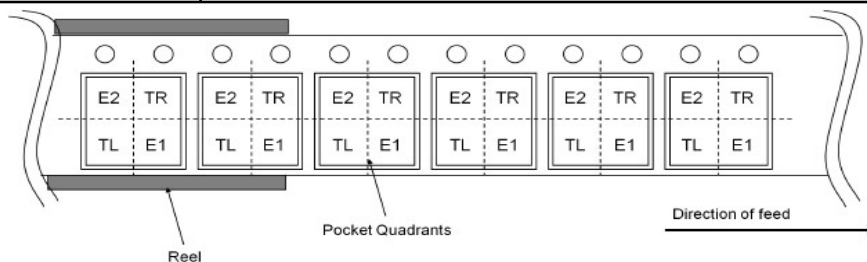

Revision History

Date	Revision	Changes
15.Mar.2022	003	New Release

Notice

Precaution on using ROHM Products

1. If you intend to use our Products in devices requiring extremely high reliability (such as medical equipment ^(Note 1), aircraft/spacecraft, nuclear power controllers, etc.) and whose malfunction or failure may cause loss of human life, bodily injury or serious damage to property ("Specific Applications"), please consult with the ROHM sales representative in advance. Unless otherwise agreed in writing by ROHM in advance, ROHM shall not be in any way responsible or liable for any damages, expenses or losses incurred by you or third parties arising from the use of any ROHM's Products for Specific Applications.

(Note1) Medical Equipment Classification of the Specific Applications

JAPAN	USA	EU	CHINA
CLASS III	CLASS III	CLASS II b	CLASS III
CLASS IV		CLASS III	

2. ROHM designs and manufactures its Products subject to strict quality control system. However, semiconductor products can fail or malfunction at a certain rate. Please be sure to implement, at your own responsibilities, adequate safety measures including but not limited to fail-safe design against the physical injury, damage to any property, which a failure or malfunction of our Products may cause. The following are examples of safety measures:
 - [a] Installation of protection circuits or other protective devices to improve system safety
 - [b] Installation of redundant circuits to reduce the impact of single or multiple circuit failure
3. Our Products are not designed under any special or extraordinary environments or conditions, as exemplified below. Accordingly, ROHM shall not be in any way responsible or liable for any damages, expenses or losses arising from the use of any ROHM's Products under any special or extraordinary environments or conditions. If you intend to use our Products under any special or extraordinary environments or conditions (as exemplified below), your independent verification and confirmation of product performance, reliability, etc. prior to use, must be necessary:
 - [a] Use of our Products in any types of liquid, including water, oils, chemicals, and organic solvents
 - [b] Use of our Products outdoors or in places where the Products are exposed to direct sunlight or dust
 - [c] Use of our Products in places where the Products are exposed to sea wind or corrosive gases, including Cl₂, H₂S, NH₃, SO₂, and NO₂
 - [d] Use of our Products in places where the Products are exposed to static electricity or electromagnetic waves
 - [e] Use of our Products in proximity to heat-producing components, plastic cords, or other flammable items
 - [f] Sealing or coating our Products with resin or other coating materials
 - [g] Use of our Products without cleaning residue of flux (Exclude cases where no-clean type fluxes is used. However, recommend sufficiently about the residue.); or Washing our Products by using water or water-soluble cleaning agents for cleaning residue after soldering
 - [h] Use of the Products in places subject to dew condensation
4. The Products are not subject to radiation-proof design.
5. Please verify and confirm characteristics of the final or mounted products in using the Products.
6. In particular, if a transient load (a large amount of load applied in a short period of time, such as pulse, is applied, confirmation of performance characteristics after on-board mounting is strongly recommended. Avoid applying power exceeding normal rated power; exceeding the power rating under steady-state loading condition may negatively affect product performance and reliability.
7. De-rate Power Dissipation depending on ambient temperature. When used in sealed area, confirm that it is the use in the range that does not exceed the maximum junction temperature.
8. Confirm that operation temperature is within the specified range described in the product specification.
9. ROHM shall not be in any way responsible or liable for failure induced under deviant condition from what is defined in this document.

Precaution for Mounting / Circuit board design

1. When a highly active halogenous (chlorine, bromine, etc.) flux is used, the residue of flux may negatively affect product performance and reliability.
2. In principle, the reflow soldering method must be used on a surface-mount products, the flow soldering method must be used on a through hole mount products. If the flow soldering method is preferred on a surface-mount products, please consult with the ROHM representative in advance.

For details, please refer to ROHM Mounting specification

Precautions Regarding Application Examples and External Circuits

1. If change is made to the constant of an external circuit, please allow a sufficient margin considering variations of the characteristics of the Products and external components, including transient characteristics, as well as static characteristics.
2. You agree that application notes, reference designs, and associated data and information contained in this document are presented only as guidance for Products use. Therefore, in case you use such information, you are solely responsible for it and you must exercise your own independent verification and judgment in the use of such information contained in this document. ROHM shall not be in any way responsible or liable for any damages, expenses or losses incurred by you or third parties arising from the use of such information.

Precaution for Electrostatic

This Product is electrostatic sensitive product, which may be damaged due to electrostatic discharge. Please take proper caution in your manufacturing process and storage so that voltage exceeding the Products maximum rating will not be applied to Products. Please take special care under dry condition (e.g. Grounding of human body / equipment / solder iron, isolation from charged objects, setting of ionizer, friction prevention and temperature / humidity control).

Precaution for Storage / Transportation

1. Product performance and soldered connections may deteriorate if the Products are stored in the places where:
 - [a] the Products are exposed to sea winds or corrosive gases, including Cl₂, H₂S, NH₃, SO₂, and NO₂
 - [b] the temperature or humidity exceeds those recommended by ROHM
 - [c] the Products are exposed to direct sunshine or condensation
 - [d] the Products are exposed to high Electrostatic
2. Even under ROHM recommended storage condition, solderability of products out of recommended storage time period may be degraded. It is strongly recommended to confirm solderability before using Products of which storage time is exceeding the recommended storage time period.
3. Store / transport cartons in the correct direction, which is indicated on a carton with a symbol. Otherwise bent leads may occur due to excessive stress applied when dropping of a carton.
4. Use Products within the specified time after opening a humidity barrier bag. Baking is required before using Products of which storage time is exceeding the recommended storage time period.

Precaution for Product Label

A two-dimensional barcode printed on ROHM Products label is for ROHM's internal use only.

Precaution for Disposition

When disposing Products please dispose them properly using an authorized industry waste company.

Precaution for Foreign Exchange and Foreign Trade act

Since concerned goods might be fallen under listed items of export control prescribed by Foreign exchange and Foreign trade act, please consult with ROHM in case of export.

Precaution Regarding Intellectual Property Rights

1. All information and data including but not limited to application example contained in this document is for reference only. ROHM does not warrant that foregoing information or data will not infringe any intellectual property rights or any other rights of any third party regarding such information or data.
2. ROHM shall not have any obligations where the claims, actions or demands arising from the combination of the Products with other articles such as components, circuits, systems or external equipment (including software).
3. No license, expressly or implied, is granted hereby under any intellectual property rights or other rights of ROHM or any third parties with respect to the Products or the information contained in this document. Provided, however, that ROHM will not assert its intellectual property rights or other rights against you or your customers to the extent necessary to manufacture or sell products containing the Products, subject to the terms and conditions herein.

Other Precaution

1. This document may not be reprinted or reproduced, in whole or in part, without prior written consent of ROHM.
2. The Products may not be disassembled, converted, modified, reproduced or otherwise changed without prior written consent of ROHM.
3. In no event shall you use in any way whatsoever the Products and the related technical information contained in the Products or this document for any military purposes, including but not limited to, the development of mass-destruction weapons.
4. The proper names of companies or products described in this document are trademarks or registered trademarks of ROHM, its affiliated companies or third parties.

General Precaution

1. Before you use our Products, you are requested to carefully read this document and fully understand its contents. ROHM shall not be in any way responsible or liable for failure, malfunction or accident arising from the use of any ROHM's Products against warning, caution or note contained in this document.
2. All information contained in this document is current as of the issuing date and subject to change without any prior notice. Before purchasing or using ROHM's Products, please confirm the latest information with a ROHM sales representative.
3. The information contained in this document is provided on an "as is" basis and ROHM does not warrant that all information contained in this document is accurate and/or error-free. ROHM shall not be in any way responsible or liable for any damages, expenses or losses incurred by you or third parties resulting from inaccuracy or errors of or concerning such information.

Looking for pricing, stock, or lifecycle information?

Click below to explore more details on WIN SOURCE:

- ⊖ [View BD82A26MUF-ME2 on WIN SOURCE](#)
- ⊖ [Rohm Semiconductor](#) Information

Optimize Your Supply Chain with WIN SOURCE Solutions

- ✓ Global Sourcing Solution
- ✓ Obsolete Management
- ✓ Cost Control Management
- ✓ Shortage Management
- ✓ Alternative Solution
- ✓ Excess Inventory Management