



MMIC SURFACE MOUNT

Wideband Amplifier

LVA-273PN+

Mini-Circuits

50Ω 0.01 to 26.5GHz Ultra-Low Additive Phase

THE BIG DEAL

- Wide Bandwidth 0.01 to 26.5GHz
- Ultra-low Phase Noise Typ. -172dBc/Hz @ 10kHz Offset
- Output P1dB Typ. +18dBm
- Output IP3 Typ. +28dBm
- Supply Voltage: +5V and 85mA
- 4x4mm 24-Lead QFN-style Package

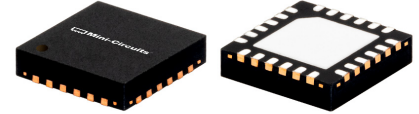

Generic photo used for illustration purposes only

APPLICATIONS

- Test and Measurement Equipment
- Radar, EW, and ECM Defense Systems
- 5G MIMO and Back Haul Radio Systems
- Signal Distribution Networks

FUNCTIONAL DIAGRAM

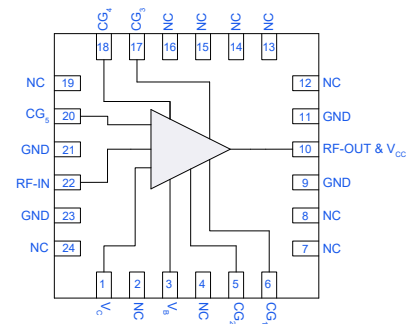

PRODUCT OVERVIEW

Mini-Circuits LVA-273PN+ is an ultra-low phase noise distributed MMIC amplifier fabricated on a GaAs HBT process technology. Operating from 0.01 to 26.5GHz, this amplifier features high dynamic range and ultra-low phase noise along with 18dB gain, +18dBm P1dB, +28dBm OIP3, and 3.7dB noise figure. The LVA-273PN+ is ideal for use with low noise signal sources and highly sensitive transceiver signal chains for commercial, industrial, and defense applications.

KEY FEATURES

Features	Advantages
Wide Bandwidth: 0.01 to 26.5GHz	Supports a broad variety of applications including Test and Measurement Equipment, 5G Microwave Radio, Radar, and Electronic Warfare Systems.
Ultra-low Phase Noise: -172dBc/Hz @ 10kHz offset	Enables the detection of signal levels in the presence of noise.
High Dynamic Range: <ul style="list-style-type: none"> • +18dBm P1dB • 18dB Gain • 3.7dB Noise Figure 	The MMIC amplifier's unique combination of ultra-low phase noise, high operating P1dB, high gain, and low noise features enable optimum performance for high dynamic range transceiver systems.
4x4mm 24-Lead QFN-style package	Small footprint saves space in dense layouts while providing low inductance, repeatable transitions, and excellent thermal contact to the PCB.





MMIC SURFACE MOUNT

Wideband Amplifier

LVA-273PN+

Mini-Circuits

50Ω 0.01 to 26.5GHz Ultra-Low Additive Phase

ELECTRICAL SPECIFICATIONS¹ AT +25°C, V_{CC} = +5V, V_C = +5V, V_B = +5V, & Z₀ = 50Ω UNLESS NOTED OTHERWISE

Parameter	Condition (GHz)	Min.	Typ.	Max.	Units
Frequency Range		0.01		26.5	GHz
Gain	0.01		19.5		dB
	5		17.7		
	10		17.7		
	20		17.2		
	26.5		17.9		
Input Return Loss	0.01		16.4		dB
	5		16.5		
	10		20.0		
	20		12.8		
	26.5		15.2		
Output Return Loss	0.01		18.2		dB
	5		14.3		
	10		14.4		
	20		13.7		
	26.5		9.1		
Isolation	0.01-26.5		41.2		dB
Output Power at 1dB Compression (P _{1dB}) ²	0.01		+19.9		dBm
	5		+17.6		
	10		+18.3		
	20		+16.1		
	26.5		+11.0		
Output Power at 3dB Compression (P _{3dB}) ³	0.01		+21.6		dBm
	5		+21.2		
	10		+20.6		
	20		+17.6		
	26.5		+13.1		
Output Third-Order Intercept Point (P _{OUT} = -2dBm/Tone)	0.01		+27.4		dBm
	5		+27.1		
	10		+27.8		
	20		+26.4		
	26.5		+19.3		
Input Third-Order Intercept Point (P _{OUT} = -2dBm/Tone)	0.01		+7.9		dBm
	5		+9.4		
	10		+10.1		
	20		+9.2		
	26.5		+1.4		
Noise Figure	2		7.7		dB
	5		4.3		
	10		3.7		
	20		5.6		
	26.5		9.2		
Additive Phase Noise (@10kHz Offset)			-172		dBc/Hz
Device Operating Voltage (V _{CC})		+4.75	+5	+5.25	V
Device Operating Current (I _{CC}) ⁴			85		mA
Control Voltage (V _C)			+5		V
Control Current (I _C)			1.2		mA
Base Voltage (V _B)			+5		V
Base Current (I _B)			4.5		mA
Device Current Variation Vs. Temperature ⁵			7		uA/°C
Device Current Variation Vs. Voltage ⁶			0.013		mA/mV

1. Tested on Mini-Circuits Characterization Test Board TB-LVA-273PNC+. See Figure 2. De-embedded to the device reference plane.

2. Defined as Output Power at which Gain is compressed by 1dB.

3. Defined as Output Power at which Gain is compressed by 3dB.

4. Current at P_{IN} = -25dBm. Increases to 105mA at P_{3dB}.

5. ((Current in mA at +105°C) - (Current in mA at -45°C))/(+150 °C)

6. ((Current in mA at +5.25V) - (Current in mA at +4.75V))/((+5.25V - +4.75V) * 1000mA/mV)





TYPICAL PERFORMANCE GRAPHS

Note: All data taken at nominal conditions $V_{CC} = +5V$, $V_C = +5V$, and $V_B = +5V$ unless noted otherwise.

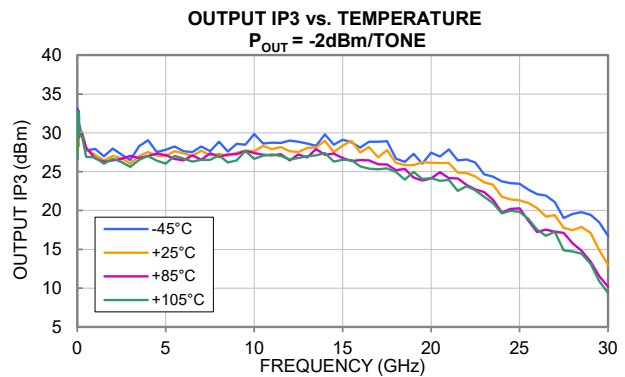
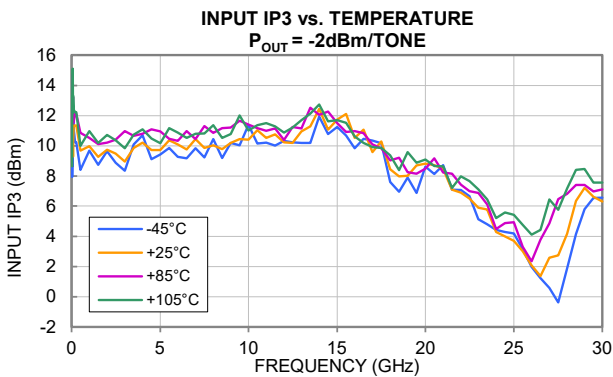
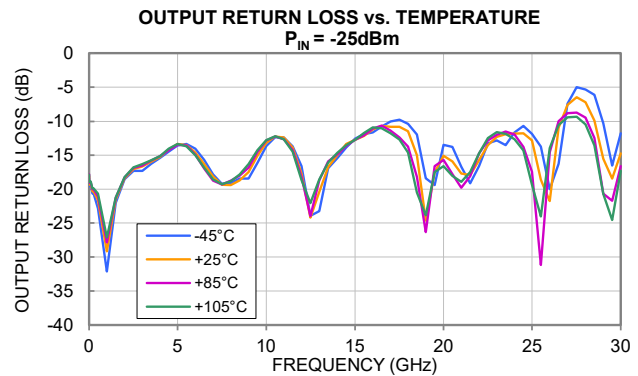
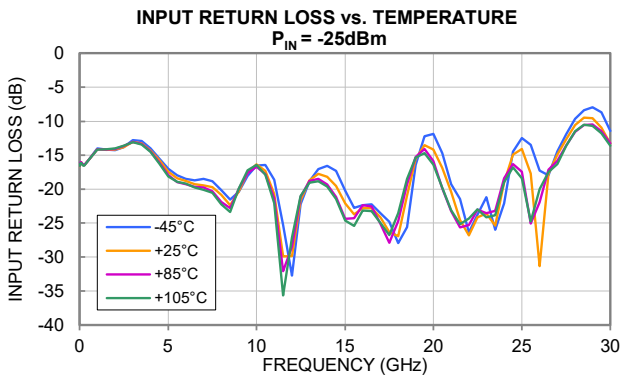
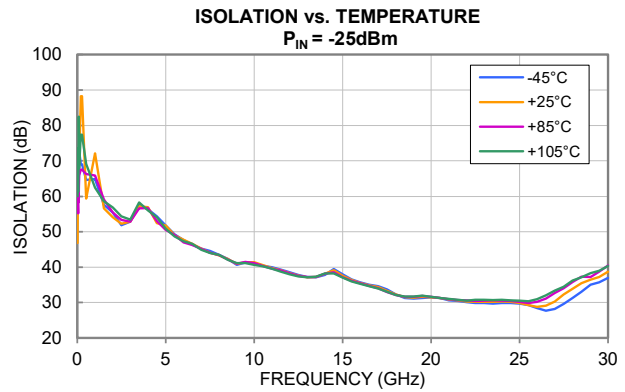
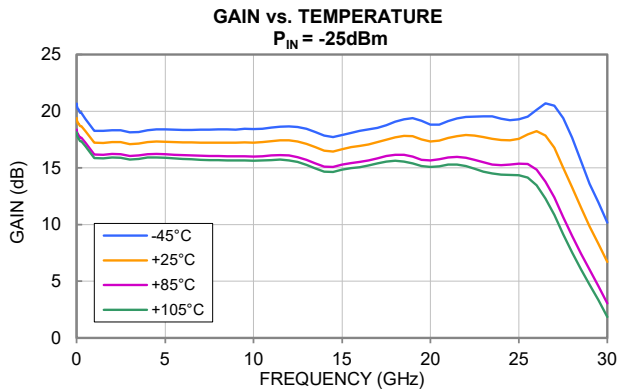



TYPICAL PERFORMANCE GRAPHS

Note: All data taken at nominal conditions $V_{CC} = +5V$, $V_C = +5V$, and $V_B = +5V$ unless noted otherwise.

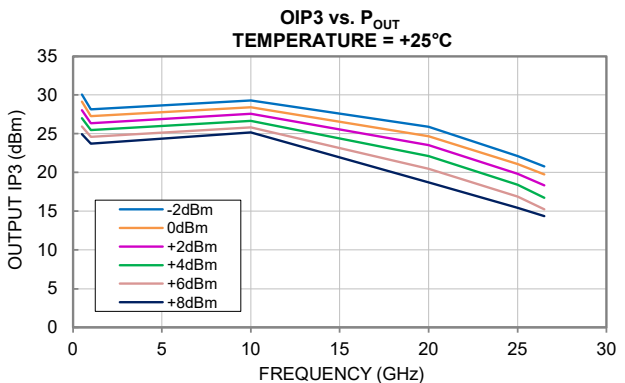
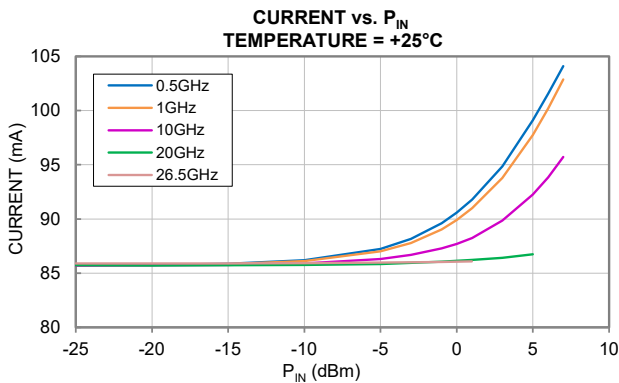
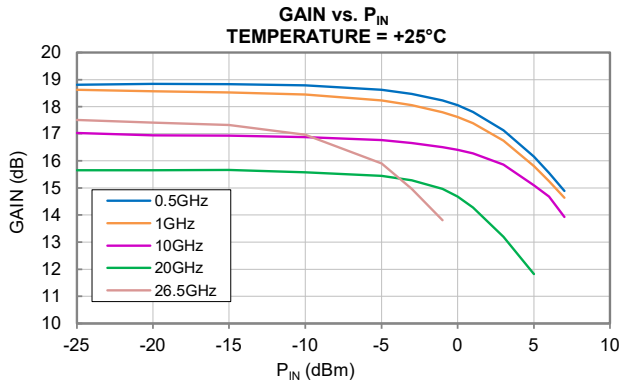
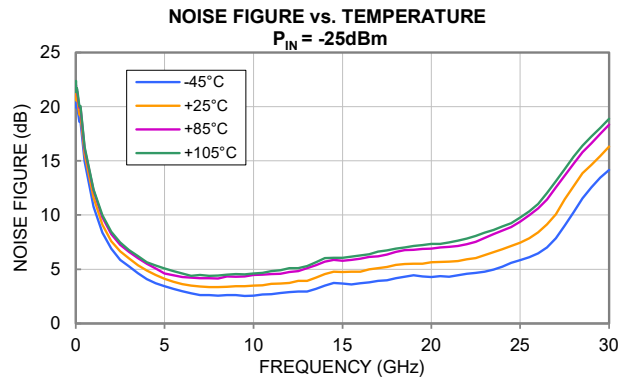
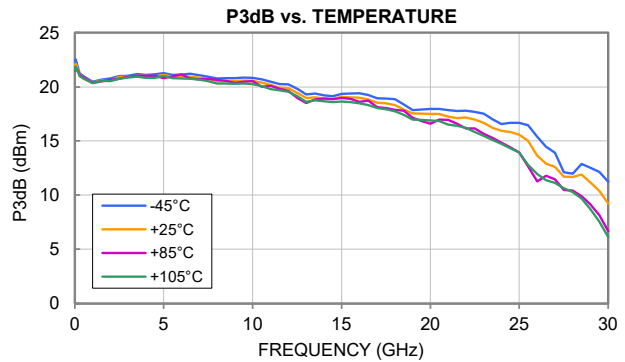
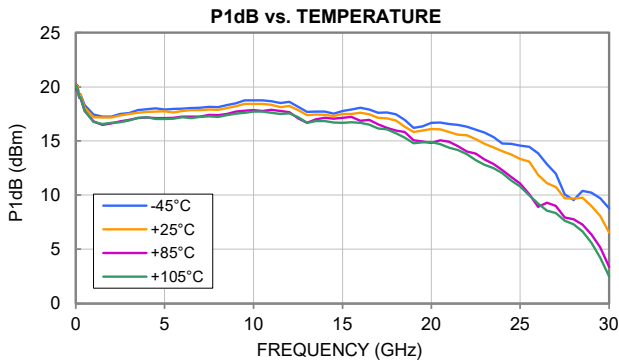



TYPICAL PERFORMANCE GRAPHS

Note: All data taken at nominal conditions $V_{CC} = +5V$, $V_C = +5V$, and $V_B = +5V$ unless noted otherwise.

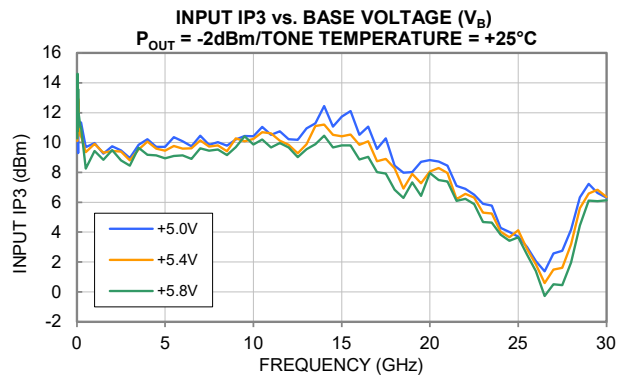
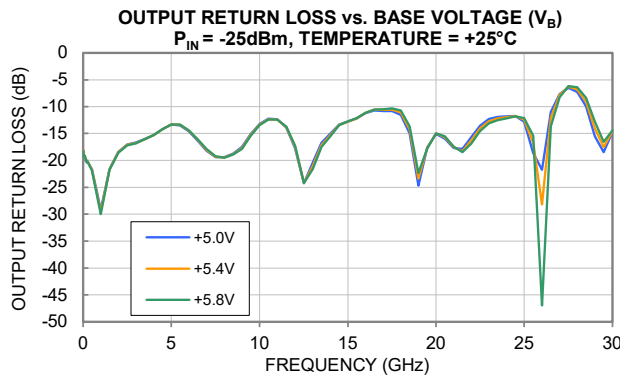
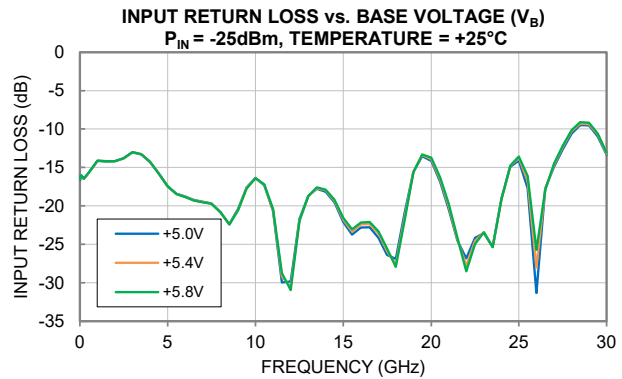
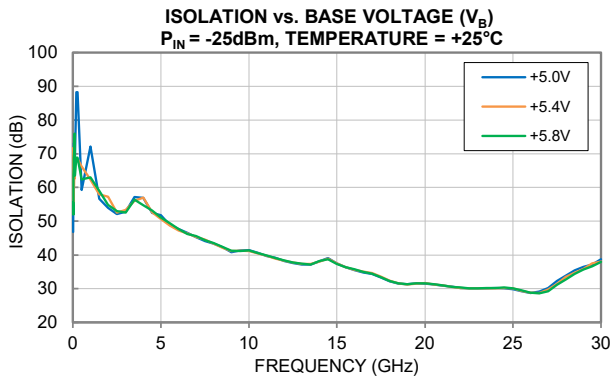
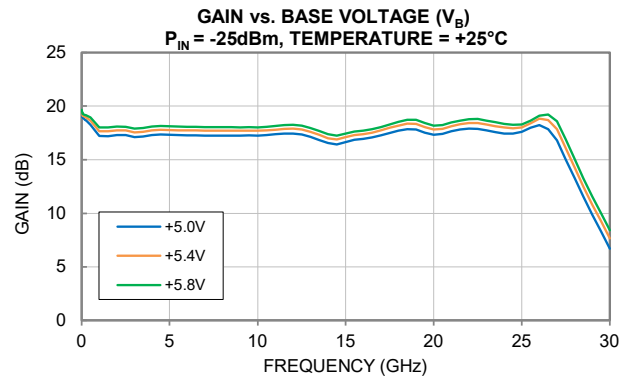
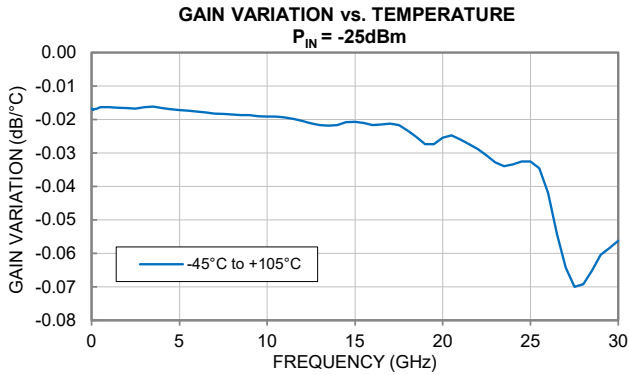



TYPICAL PERFORMANCE GRAPHS

Note: All data taken at nominal conditions $V_{CC} = +5V$ and $V_C = +5V$ unless noted otherwise.

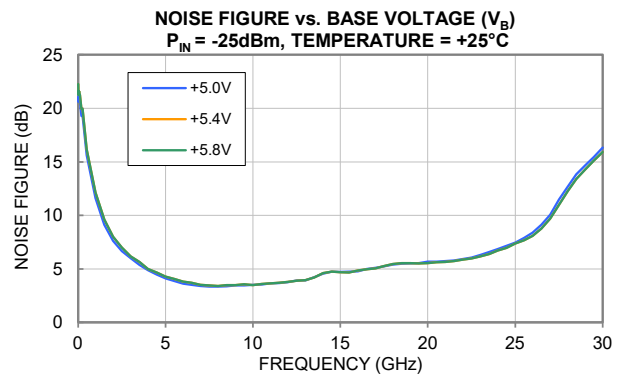
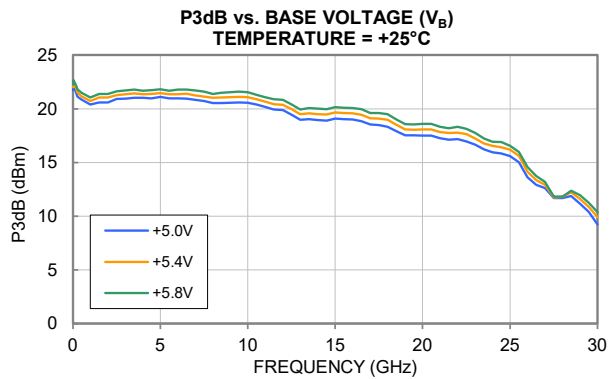
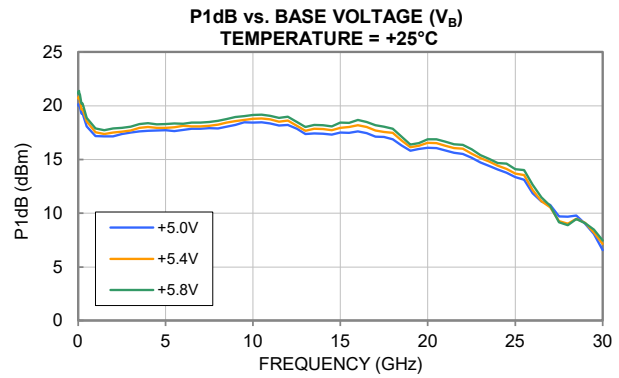
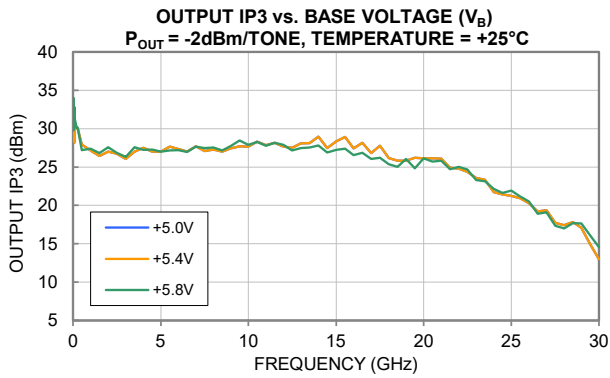



MMIC SURFACE MOUNT

Wideband Amplifier

LVA-273PN+

Mini-Circuits

50Ω 0.01 to 26.5GHz Ultra-Low Additive Phase

TYPICAL PERFORMANCE GRAPHS

Note: All data taken at nominal conditions $V_{CC} = +5V$, $V_C = +5V$, and $V_B = +5V$ unless noted otherwise.

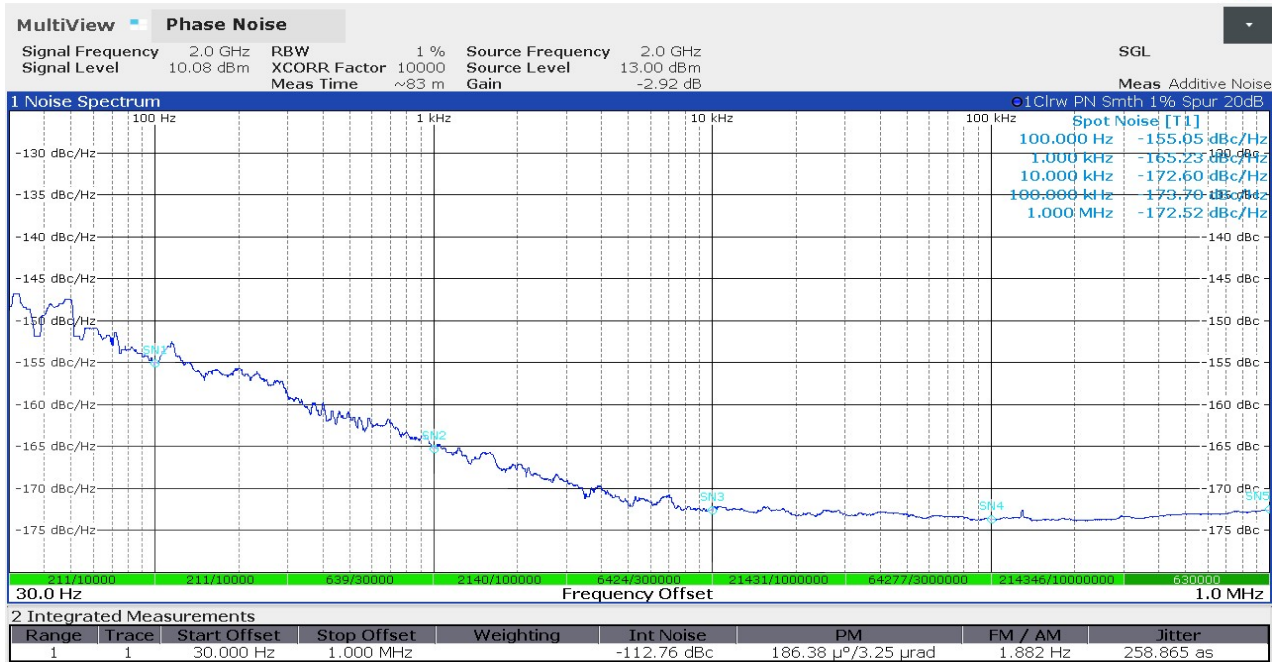



MMIC SURFACE MOUNT

Wideband Amplifier

LVA-273PN+

50Ω 0.01 to 26.5GHz Ultra-Low Additive Phase

ABSOLUTE MAXIMUM RATINGS⁷

Parameter	Ratings
Operating Temperature (ground lead)	-45°C to +105°C
Storage Temperature	-65°C to +150°C
Total Power Dissipation	1.54W
Junction Temperature ⁸	+150°C
Input Power (CW), $V_{CC} = +5V$, $V_C = +5V$, $V_B = +5V$	+25dBm
DC Voltage on RF-OUT & V_{CC}	+10V
DC Voltage on RF-IN	+10V
Current I_{CC}	150mA
DC Voltage on V_C	+10V
Current I_C	5mA
DC Voltage on V_B	+10V
Current I_B	14mA

7. Permanent damage may occur if any of these limits are exceeded. Maximum ratings are not intended for continuous normal operation.

8. Peak temperature on top of Die.

THERMAL RESISTANCE

Parameter	Ratings
Thermal Resistance (Θ_{jc}) ⁹	29.2°C/W

9. Θ_{jc} = (Hot Spot Temperature on Die - Temperature at Ground Lead)/Dissipated Power

ESD RATING

	Class	Voltage Range	Reference Standard
HBM	1B	500V to < 1000V	ANSI/ESDA/JEDEC JS-001-2017
CDM	C2	500V to < 1000V	JESD22-C101F



ESD HANDLING PRECAUTION: This device is designed to be Class 1B for HBM. Static charges may easily produce potentials higher than this with improper handling and can discharge into DUT and damage it. As a preventive measure, industry standard ESD handling precautions should be used at all times to protect the device from ESD damage.

MSL RATING

Moisture Sensitivity: MSL1 in accordance with IPC/JEDEC J-STD-020E/JEDEC J-STD-033C





MMIC SURFACE MOUNT

Wideband Amplifier

LVA-273PN+

Mini-Circuits

50Ω 0.01 to 26.5GHz Ultra-Low Additive Phase

FUNCTIONAL DIAGRAM

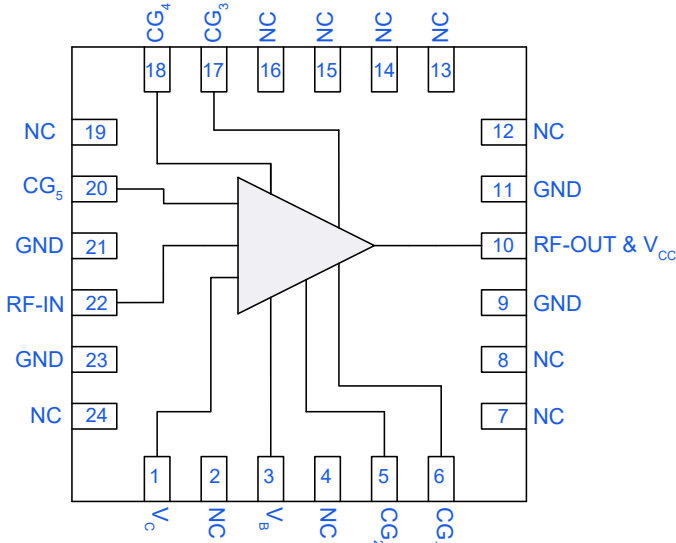
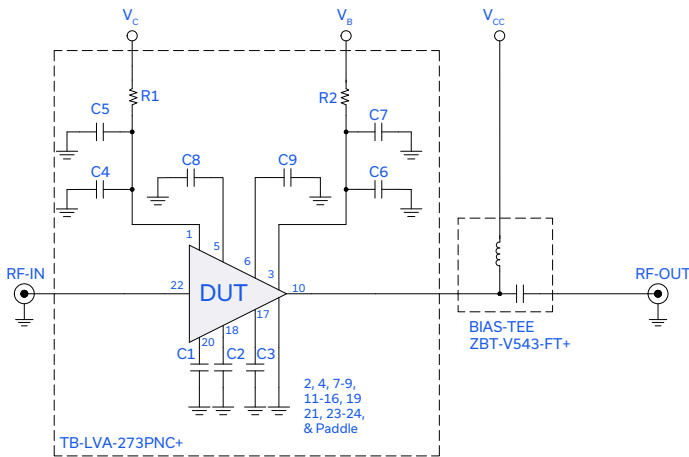

Figure 1. LVA-273PN+ Functional Diagram

PAD DESCRIPTION

Function	Pad Number	Application Description (Refer to Figure 2)
RF-IN	22	RF-IN Pad connects to RF input port.
RF-OUT & V _{CC}	10	RF-OUT Pad connects to RF output and V _{CC} port.
V _C	1	DC Input Pad connects to voltage input port, V _C .
V _B	3	DC Input Pad connects to voltage input port, V _B .
CG ₁	6	Connects to AC ground through external capacitor C9.
CG ₂	5	Connects to AC ground through external capacitor C8.
CG ₃	17	Connects to AC ground through external capacitor C3.
CG ₄	18	Connects to AC ground through external capacitor C2.
CG ₅	20	Connects to AC ground through external capacitor C1.
GND	9, 11, 21, 23, & Paddle	Connects to ground.
NC	2, 4, 7, 8, 12-16, 19, 24	Not used internally. Connects to ground on evaluation board.

EVALUATION BOARD



Electrical Parameters and Conditions

Gain, Return Loss, Output Power at 1dB Compression (P1dB), Output Power at 3dB Compression (P3dB), Output IP3 (OIP3), and Noise Figure measured using N5247B PNA-X Microwave Network Analyzer.

Conditions:

- Gain, Noise Figure, and Return Loss: P_{IN} = -25dBm.
- Output IP3 (OIP3): Two tones, spaced 1MHz apart, -2dBm/tone at output.

Power ON/Power OFF Sequence

Caution: Permanent damage to the device will occur if the Power ON and Power OFF Sequences are not followed.

Power ON:

- Set V_{CC} = +5V.
- Set V_C = +5V.
- Set V_B = +5V.
- Turn on V_{CC}, V_C, and V_B.
- Apply RF Signal.

Power OFF:

- Turn off RF Signal.
- Turn off V_{CC}, V_C, and V_B.

Note: Bias Tee ZBT-V543-FT+ is external to the Evaluation Board TB-LVA-273PNC+

Figure 2. DUT soldered on Mini-Circuits Evaluation Board: TB-LVA-273PNC+

Component	Value	Size	Part Number	Manufacturer
C1	5100pF	0603	GCM1885C1H512JA16D	Murata
C2	1μF	0603	GCM188R71E105KA64J	Murata
C3, C9	1000pF	0402	GRM1555C1H102JA01D	Murata
C4, C6	100pF	0402	GRM1555C1H101JA01D	Murata
C5, C7, C8	0.1μF	0402	GRM155R71H104KE14J	Murata
R1, R2	0Ω	0402	RK73Z1ETTP	KOA Spear





MMIC SURFACE MOUNT

Wideband Amplifier

LVA-273PN+

Mini-Circuits

50Ω 0.01 to 26.5GHz Ultra-Low Additive Phase

CASE STYLE DRAWING

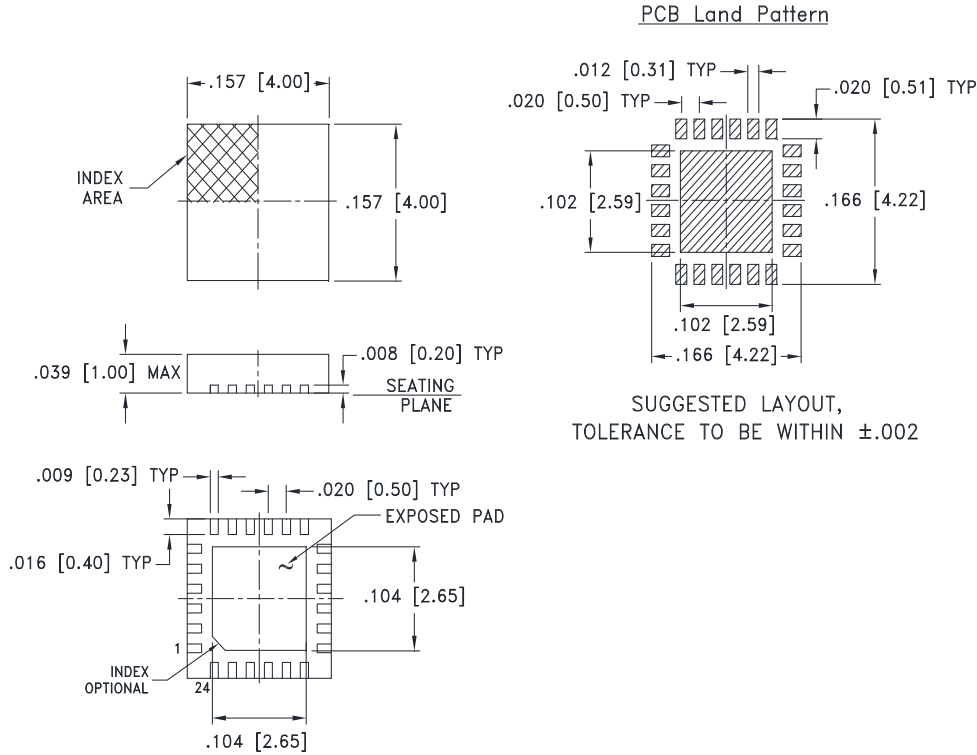

Weight: .04 Grams

Dimensions are in inches [mm]. Tolerances: 2 Pl. ± .01; 3 Pl. ± .005

PRODUCT MARKING

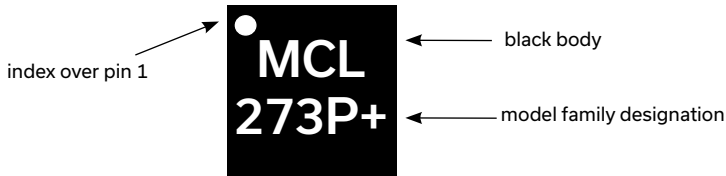

Marking may contain other features or characters for internal lot control





MMIC SURFACE MOUNT

Wideband Amplifier

LVA-273PN+

50Ω 0.01 to 26.5GHz Ultra-Low Additive Phase

ADDITIONAL DETAILED INFORMATION IS AVAILABLE ON OUR DASH BOARD

[CLICK HERE](#)

Performance Data & Graphs	Data
	Graphs
	S-Parameter (S2P Files) Data Set (.zip file)
Case Style	DG1847 Plastic package, exposed paddle, Lead Finish: Matte-Tin
RoHs Status	Compliant
Tape & Reel Standard quantities available on reel	F68 7" reels with 20, 50, 100, 200, 500, or 1K devices
Suggested Layout for PCB Design	PL-756
Evaluation Board	TB-LVA-273PNC+
	Gerber File
Environmental Ratings	ENV08T1

NOTES

- A. Performance and quality attributes and conditions not expressly stated in this specification document are intended to be excluded and do not form a part of this specification document.
- B. Electrical specifications and performance data contained in this specification document are based on Mini-Circuit's applicable established test performance criteria and measurement instructions.
- C. The parts covered by this specification document are subject to Mini-Circuits standard limited warranty and terms and conditions (collectively, "Standard Terms"); Purchasers of this part are entitled to the rights and benefits contained therein. For a full statement of the standard terms and the exclusive rights and remedies thereunder, please visit Mini-Circuits' website at www.minicircuits.com/terms/viewterm.html



Looking for pricing, stock, or lifecycle information?

Click below to explore more details on WIN SOURCE:

 [View LVA-273PN+](#) on WIN SOURCE

 [Mini-Circuits](#) Information

Optimize Your Supply Chain with WIN SOURCE Solutions

-  Global Sourcing Solution
-  Obsolete Management
-  Cost Control Management
-  Shortage Management
-  Alternative Solution
-  Excess Inventory Management