

# TRF1108 Near-DC to 8GHz, Differential to Single-Ended RF Amplifier

## 1 Features

- Differential-to-single-ended (D2S) RF amplifier
- Near-DC to 8GHz
- Gain: 15.5dB at 2GHz
- OP1dB:
  - 2GHz: 12dBm
  - 6GHz: 10dBm
- OIP3:
  - 2GHz: 28dBm
  - 6GHz: 28.5dBm
- Noise figure (NF) and input noise spectral density:
  - 2GHz: 11dB and –163dBm/Hz
  - 6GHz: 11.5dB and –162.5dBm/Hz
- HD2 and HD3:
  - HD2 (1GHz): –60dBc at 2dBm
  - HD3 (1GHz): –58dBc at 2dBm
- Additive (residual) phase noise:
  - 1GHz: –154.6dBc/Hz at 10kHz offset
- Gain and phase imbalance:  $\pm 0.6$ dB and  $\pm 2^\circ$
- Differential input matched to 100 $\Omega$
- Single-ended output matched to 50 $\Omega$
- Power-down feature
- 5V supply
- Active current: 170mA

## 2 Applications

- Directly interfaces with RF DACs
- [Aerospace and defense](#)
- [Phased array radar](#)
- [Military radios](#)
- [4G and 5G wireless BTS](#)
- [Test and measurement](#)
- Active probe

## 3 Description

The TRF1108 is a very high-performance, differential-to-single-ended (D2S) amplifier optimized for radio-frequency (RF) applications. The device is an excellent choice for applications that require a D2S conversion at the output of digital-to-analog converter (DAC) such as the high-performance [DAC39RF10](#) or [AFE7950](#). The on-chip matching components simplify printed-circuit-board (PCB) implementation and provide the highest performance over the usable bandwidth. The device is fabricated using Texas Instruments' advanced complementary BiCMOS process and is available in a space-saving, WQFN-FCRLF 2mm × 2mm package.

The primary use-case of the TRF1108 is in ac-coupled applications, where the device operates using a single, 5V supply with an internally set common-mode voltage that simplifies biasing. With the help of an application circuit to set the input common-mode voltage, and by using dual supplies, the amplifier can be dc-coupled. A power-down feature is also available for power savings.

### Package Information

| PART NUMBER <sup>(1)</sup> | PACKAGE              | PACKAGE SIZE <sup>(2)</sup> |
|----------------------------|----------------------|-----------------------------|
| TRF1108                    | RPV (WQFN-FCRLF, 12) | 2mm × 2mm                   |

(1) For more information, see [Section 10](#).

(2) The package size (length × width) is a nominal value and includes pins.

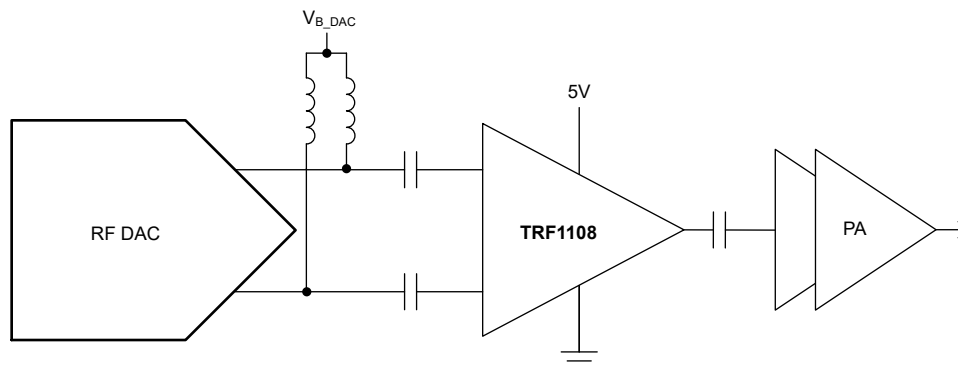

TRF1108 Driven by an RF DAC



## Table of Contents

|  |           |  |           |
|--|-----------|--|-----------|
| <b>1 Features</b> .....                        | <b>1</b>  | <b>7 Application and Implementation</b> .....                    | <b>19</b> |
| <b>2 Applications</b> .....                    | <b>1</b>  | 7.1 Application Information.....                                 | 19        |
| <b>3 Description</b> .....                     | <b>1</b>  | 7.2 Typical Application.....                                     | 19        |
| <b>4 Pin Configuration and Functions</b> ..... | <b>3</b>  | 7.3 Power Supply Recommendations.....                            | 21        |
| <b>5 Specifications</b> .....                  | <b>4</b>  | 7.4 Layout.....  | 21        |
| 5.1 Absolute Maximum Ratings.....              | 4         | <b>8 Device and Documentation Support</b> .....                  | <b>24</b> |
| 5.2 ESD Ratings.....                           | 4         | 8.1 Documentation Support.....                                   | 24        |
| 5.3 Recommended Operating Conditions.....      | 4         | 8.2 Receiving Notification of Documentation Updates.....         | 24        |
| 5.4 Thermal Information.....                   | 4         | 8.3 Support Resources.....                                       | 24        |
| 5.5 Electrical Characteristics.....            | 5         | 8.4 Trademarks.....  | 24        |
| 5.6 Typical Characteristics.....               | 7         | 8.5 Electrostatic Discharge Caution.....                         | 24        |
| <b>6 Detailed Description</b> .....            | <b>17</b> | 8.6 Glossary.....  | 24        |
| 6.1 Overview.....                              | 17        | <b>9 Revision History</b> .....                                  | <b>24</b> |
| 6.2 Functional Block Diagram.....              | 17        | <b>10 Mechanical, Packaging, and Orderable Information</b> ..... | <b>24</b> |
| 6.3 Feature Description.....                   | 17        |  |           |
| 6.4 Device Functional Modes.....               | 18        |  |           |

## 4 Pin Configuration and Functions

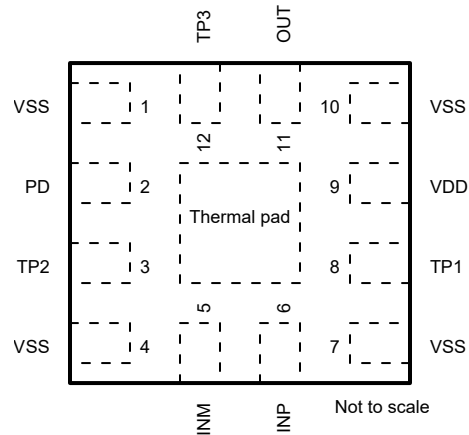

**Figure 4-1. RPV Package, 12-Pin WQFN-FCRLF (Top View)**

**Table 4-1. Pin Functions**

| PIN         |             | TYPE   | DESCRIPTION  |
|-------------|-------------|--------|--|
| NAME        | NO.         |        |  |
| INM         | 5           | Input  | Differential signal input, negative  |
| INP         | 6           | Input  | Differential signal input, positive  |
| OUT         | 11          | Output | Single ended output  |
| PD          | 2           | Input  | Power-down signal. Supports 1.8V and 3.3V logic referenced to VSS.<br>0 = Chip enabled<br>1 = Power down |
| TP1         | 8           | —      | Test pin. Connect to VSS   |
| TP2         | 3           | —      | Test pin. Connect to VSS   |
| TP3         | 12          | —      | Test pin. Connect to VSS   |
| VDD         | 9           | Power  | Positive supply pin  |
| VSS         | 1, 4, 7, 10 | Power  | Negative supply pin  |
| Thermal pad | Pad         | —      | Thermal pad. Connect to VSS  |

## 5 Specifications

### 5.1 Absolute Maximum Ratings

over operating free-air temperature range (unless otherwise noted)<sup>(1)</sup>

|           |  | MIN            | MAX                  | UNIT |
|-----------|--|----------------|----------------------|------|
| $V_{SS}$  | Negative supply voltage, referenced to RF ground | -3.8           | 0.3                  | V    |
| $V_{DD}$  | Positive supply voltage                          | $V_{SS} - 0.3$ | $V_{SS} + 5.5$       | V    |
| $V_{PD}$  | Power-down pin voltage                           | $V_{SS} - 0.3$ | $V_{SS} + 3.7^{(2)}$ | V    |
| INP, INM  | Input pin power                                  |                | 20 <sup>(3)</sup>    | dBm  |
| $T_J$     | Junction temperature                             | -40            | 150                  | °C   |
| $T_{stg}$ | Storage temperature                              | -40            | 150                  | °C   |

- (1) Operation outside the *Absolute Maximum Ratings* may cause permanent device damage. *Absolute Maximum Ratings* do not imply functional operation of the device at these or any other conditions beyond those listed under *Recommended Operating Conditions*. If used outside the *Recommended Operating Conditions* but within the *Absolute Maximum Ratings*, the device may not be fully functional, and this may affect device reliability, functionality, performance, and shorten the device lifetime.
- (2) When  $V_{DD}$  is present; otherwise, maximum value is  $V_{SS} + 0.3V$ .
- (3) When device supplies are present; otherwise, limit swing at the device pins to  $V_{SS} \pm 0.3V$ .

### 5.2 ESD Ratings

|             |                         |   | VALUE | UNIT |
|-------------|-------------------------|---|-------|------|
| $V_{(ESD)}$ | Electrostatic discharge | Human body model (HBM), per ANSI/ESDA/JEDEC JS-001, all pins <sup>(1)</sup>     | ±1000 | V    |
|             |                         | Charged device model (CDM), per ANSI/ESDA/JEDEC JS-002, all pins <sup>(2)</sup> | ±250  |      |

- (1) JEDEC document JEP155 states that 500V HBM allows safe manufacturing with a standard ESD control process.
- (2) JEDEC document JEP157 states that 250V CDM allows safe manufacturing with a standard ESD control process.

### 5.3 Recommended Operating Conditions

over operating free-air temperature range (unless otherwise noted)

|          |  | MIN             | NOM          | MAX             | UNIT |
|----------|--|-----------------|--------------|-----------------|------|
| $V_{SS}$ | Negative supply voltage, referenced to RF ground | -3.5            |              | 0               | V    |
| $V_{DD}$ | Positive supply voltage                          | $V_{SS} + 4.75$ | $V_{SS} + 5$ | $V_{SS} + 5.25$ | V    |
| $T_A$    | Ambient air temperature                          | -40             | 25           |                 | °C   |
| $T_J$    | Junction temperature                             |                 |              | 125             | °C   |

### 5.4 Thermal Information

| THERMAL METRIC <sup>(1)</sup> |  | TRF1108          | UNIT |
|-------------------------------|--|------------------|------|
|                               |  | RPV (WQFN-FCRLF) |      |
|                               |  | 12 PINS          |      |
| $R_{\theta JA}$               | Junction-to-ambient thermal resistance       | 66.7             | °C/W |
| $R_{\theta JC(top)}$          | Junction-to-case (top) thermal resistance    | 35.3             | °C/W |
| $R_{\theta JB}$               | Junction-to-board thermal resistance         | 31.1             | °C/W |
| $\Psi_{JT}$                   | Junction-to-top characterization parameter   | 0.6              | °C/W |
| $\Psi_{JB}$                   | Junction-to-board characterization parameter | 31.1             | °C/W |
| $R_{\theta JC(bot)}$          | Junction-to-case (bottom) thermal resistance | 10.7             | °C/W |

- (1) For more information about traditional and new thermal metrics, see the [Semiconductor and IC Package Thermal Metrics](#) application report.

## 5.5 Electrical Characteristics

at  $T_A = 25^\circ\text{C}$ , single supply operation with  $V_{DD} = 5\text{V}$ , 100nF ac-coupling capacitors at input and output, differential input with  $R_S = 100\Omega$ , output with  $R_L = 50\Omega$  (unless otherwise noted)

| PARAMETER             |                                     | TEST CONDITIONS   | MIN | TYP  | MAX | UNIT    |
|-----------------------|-------------------------------------|---|-----|------|-----|---------|
| <b>AC PERFORMANCE</b> |                                     |   |     |      |     |         |
| Ssd21                 | Gain                                | f = 0.5GHz  |     | 15.4 |     | dB      |
|                       |                                     | f = 2GHz  |     | 15.5 |     |         |
|                       |                                     | f = 4GHz  |     | 16.3 |     |         |
|                       |                                     | f = 6GHz  |     | 17.4 |     |         |
|                       |                                     | f = 8GHz  |     | 18   |     |         |
| Sdd11                 | Input return loss                   | f = 10MHz to 8GHz   |     | -15  |     | dB      |
| Sss22                 | Output return loss                  | f = 10MHz to 8GHz   |     | -12  |     | dB      |
| Sds12                 | Reverse isolation                   | f = 10MHz to 8GHz   |     | -45  |     | dB      |
| lmb <sub>GAIN</sub>   | Gain imbalance                      | f = 10MHz to 8GHz   |     | ±0.6 |     | dB      |
| lmb <sub>PHASE</sub>  | Phase imbalance                     | f = 10MHz to 8GHz   |     | ±2   |     | degrees |
| CMRR                  | Common-mode rejection ratio         | f = 2GHz  |     | -45  |     | dB      |
| OP1dB                 | Output 1dB compression point        | f = 0.5GHz  |     | 12   |     | dBm     |
|                       |                                     | f = 2GHz  |     | 12   |     |         |
|                       |                                     | f = 4GHz  |     | 12   |     |         |
|                       |                                     | f = 6GHz  |     | 10   |     |         |
|                       |                                     | f = 8GHz  |     | 8    |     |         |
| NF                    | Noise figure                        | f = 0.5GHz  |     | 10.5 |     | dB      |
|                       |                                     | f = 2GHz  |     | 11   |     |         |
|                       |                                     | f = 4GHz  |     | 11   |     |         |
|                       |                                     | f = 6GHz  |     | 11.5 |     |         |
|                       |                                     | f = 8GHz  |     | 12.5 |     |         |
| OIP2                  | Output second-order intercept point | f = 0.5GHz, $P_{out} = -4\text{dBm}$ per tone (10MHz spacing) |     | 63   |     | dBm     |
|                       |                                     | f = 1GHz, $P_{out} = -4\text{dBm}$ per tone (10MHz spacing)   |     | 57   |     |         |
|                       |                                     | f = 2GHz, $P_{out} = -4\text{dBm}$ per tone (10MHz spacing)   |     | 46   |     |         |
|                       |                                     | f = 4GHz, $P_{out} = -4\text{dBm}$ per tone (10MHz spacing)   |     | 34   |     |         |
| OIP3                  | Output third-order intercept point  | f = 0.5GHz, $P_{out} = -4\text{dBm}$ per tone (10MHz spacing) |     | 32   |     | dBm     |
|                       |                                     | f = 2GHz, $P_{out} = -4\text{dBm}$ per tone (10MHz spacing)   |     | 28   |     |         |
|                       |                                     | f = 4GHz, $P_{out} = -4\text{dBm}$ per tone (10MHz spacing)   |     | 27   |     |         |
|                       |                                     | f = 6GHz, $P_{out} = -4\text{dBm}$ per tone (10MHz spacing)   |     | 28.5 |     |         |
|                       |                                     | f = 8GHz, $P_{out} = -4\text{dBm}$ per tone (10MHz spacing)   |     | 20   |     |         |
| HD2                   | Second-order harmonic distortion    | f = 0.5GHz, $P_{out} = 2\text{dBm}$                           |     | -68  |     | dBc     |
|                       |                                     | f = 1GHz, $P_{out} = 2\text{dBm}$                             |     | -60  |     |         |
|                       |                                     | f = 2GHz, $P_{out} = 2\text{dBm}$                             |     | -52  |     |         |
|                       |                                     | f = 4GHz, $P_{out} = 2\text{dBm}$                             |     | -39  |     |         |

## 5.5 Electrical Characteristics (continued)

at  $T_A = 25^\circ\text{C}$ , single supply operation with  $V_{DD} = 5\text{V}$ , 100nF ac-coupling capacitors at input and output, differential input with  $R_S = 100\Omega$ , output with  $R_L = 50\Omega$  (unless otherwise noted)

| PARAMETER                 |   | TEST CONDITIONS   | MIN | TYP             | MAX | UNIT          |
|---------------------------|---|---|-----|-----------------|-----|---------------|
| HD3                       | Third-order harmonic distortion         | $f = 0.5\text{GHz}$ , $P_{out} = 2\text{dBm}$                           |     | -63             |     | dBc           |
|                           |   | $f = 1\text{GHz}$ , $P_{out} = 2\text{dBm}$                             |     | -58             |     |               |
|                           |   | $f = 2\text{GHz}$ , $P_{out} = 2\text{dBm}$                             |     | -51             |     |               |
| IMD2                      | Second-order intermodulation distortion | $f = 0.5\text{GHz}$ , $P_{out} = -4\text{dBm}$ per tone (10MHz spacing) |     | -67             |     | dBc           |
|                           |   | $f = 1\text{GHz}$ , $P_{out} = -4\text{dBm}$ per tone (10MHz spacing)   |     | -61             |     |               |
|                           |   | $f = 2\text{GHz}$ , $P_{out} = -4\text{dBm}$ per tone (10MHz spacing)   |     | -50             |     |               |
|                           |   | $f = 4\text{GHz}$ , $P_{out} = -4\text{dBm}$ per tone (10MHz spacing)   |     | -38             |     |               |
| IMD3                      | Third-order intermodulation distortion  | $f = 0.5\text{GHz}$ , $P_{out} = -4\text{dBm}$ per tone (10MHz spacing) |     | -72             |     | dBc           |
|                           |   | $f = 2\text{GHz}$ , $P_{out} = -4\text{dBm}$ per tone (10MHz spacing)   |     | -64             |     |               |
|                           |   | $f = 4\text{GHz}$ , $P_{out} = -4\text{dBm}$ per tone (10MHz spacing)   |     | -62             |     |               |
|                           |   | $f = 6\text{GHz}$ , $P_{out} = -4\text{dBm}$ per tone (10MHz spacing)   |     | -65             |     |               |
|                           |   | $f = 8\text{GHz}$ , $P_{out} = -4\text{dBm}$ per tone (10MHz spacing)   |     | -48             |     |               |
| PN                        | Additive (residual) phase noise         | $f = 1\text{GHz}$ , $P_{out} = 6\text{dBm}$ , 100Hz offset              |     | -138.9          |     | dBc/Hz        |
|                           |   | $f = 1\text{GHz}$ , $P_{out} = 6\text{dBm}$ , 1kHz offset               |     | -148            |     |               |
|                           |   | $f = 1\text{GHz}$ , $P_{out} = 6\text{dBm}$ , 10kHz offset              |     | -154.6          |     |               |
| <b>DC CHARACTERISTICS</b> |   |   |     |                 |     |               |
| $V_{ICM}$                 | Input common-mode voltage               |   |     | $V_{SS} + 1.34$ |     | V             |
| $V_{OB}$                  | DC output bias voltage                  |   |     | $V_{DD} - 1.68$ |     | V             |
| $Z_I$                     | Differential input impedance            | $f = \text{dc}$ (internal to the device)                                |     | 100             |     | $\Omega$      |
| $Z_O$                     | Single-ended output impedance           | $f = \text{dc}$ (internal to the device)                                |     | 30              |     | $\Omega$      |
| <b>TRANSIENT</b>          |   |   |     |                 |     |               |
| $t_{REC}$                 | Overdrive recovery time                 | Using a 0.9Vp differential input pulse duration of 1.5ns                |     | 2               |     | ns            |
| <b>POWER SUPPLY</b>       |   |   |     |                 |     |               |
| $I_{QA}$                  | Active current                          | Current on $V_{DD}$ pin, PD = 0   |     | 170             |     | mA            |
| $I_{QPD}$                 | Power-down quiescent current            | Current on $V_{DD}$ pin, PD = 1   |     | 13              |     | mA            |
| <b>POWER DOWN</b>         |   |   |     |                 |     |               |
| $V_{PDHIGH}$              | PD pin logic high                       |   |     | $V_{SS} + 1.45$ |     | V             |
| $V_{PDLow}$               | PD pin logic low                        |   |     | $V_{SS} + 0.8$  |     | V             |
| $I_{PDBIAS}$              | PD bias current                         | Current on PD pin, PD = high (1.8V logic)                               |     | 40              | 75  | $\mu\text{A}$ |
|                           |   | Current on PD pin, PD = high (3.3V logic)                               |     | 200             | 250 | $\mu\text{A}$ |
| $C_{PD}$                  | PD pin capacitance                      |   |     | 2               |     | pF            |

## 5.6 Typical Characteristics

at  $T_A = 25^\circ\text{C}$ , temperature curves specify ambient temperature, single-supply operation with  $V_{DD} = 5\text{V}$ , 100nF ac-coupling capacitors at input and output, differential input with  $R_S = 100\Omega$ , and output with  $R_L = 50\Omega$  (unless otherwise noted)

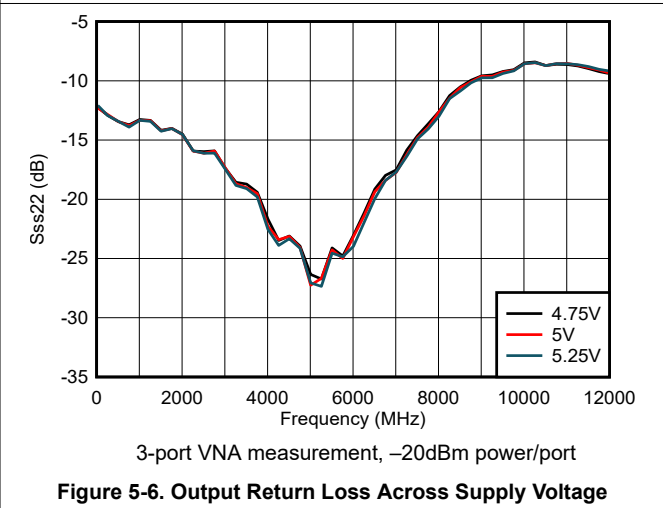
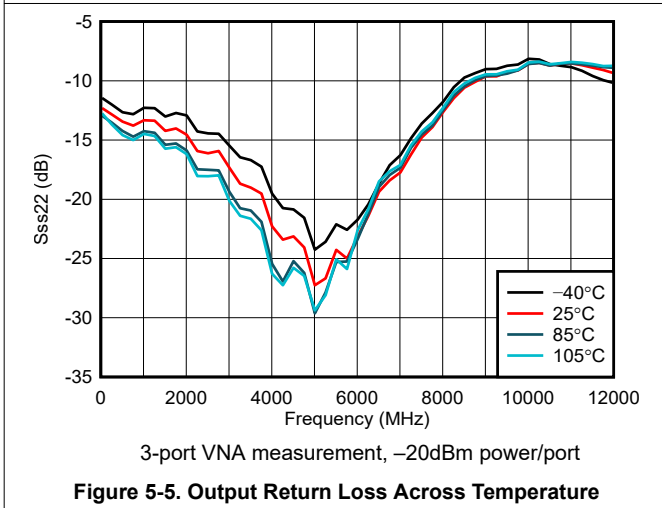
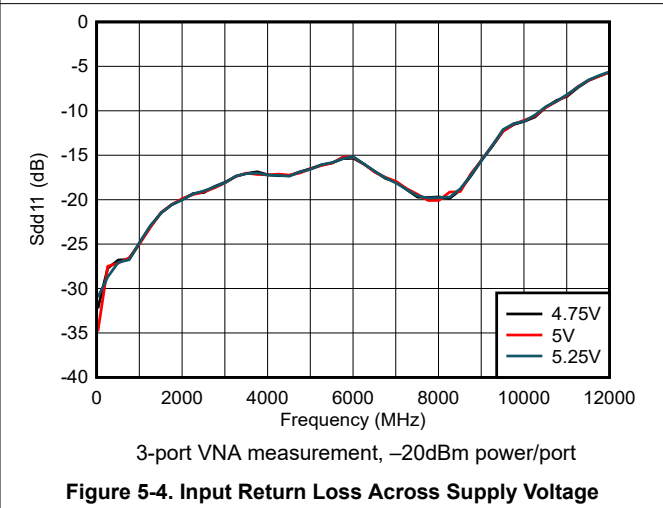
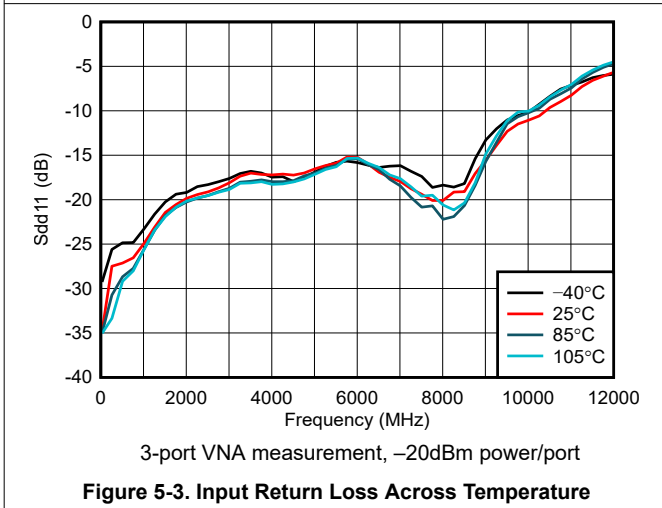
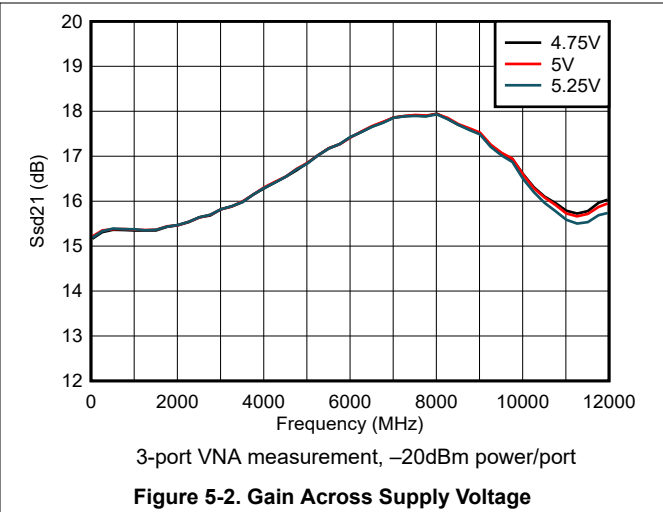
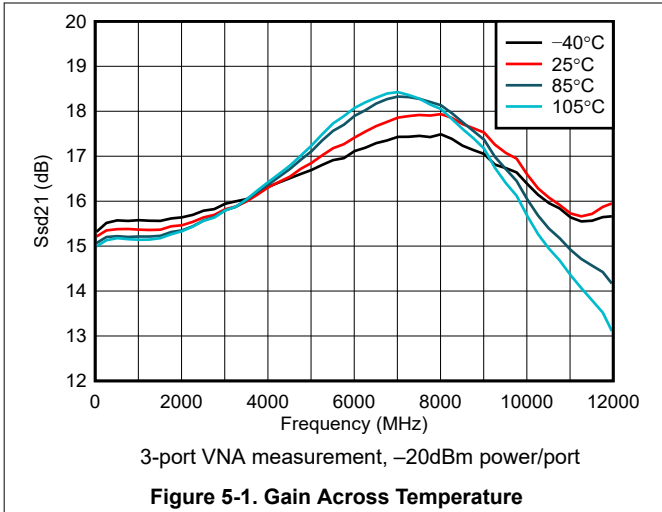

### 5.6 Typical Characteristics (continued)

at  $T_A = 25^\circ\text{C}$ , temperature curves specify ambient temperature, single-supply operation with  $V_{DD} = 5\text{V}$ , 100nF ac-coupling capacitors at input and output, differential input with  $R_S = 100\Omega$ , and output with  $R_L = 50\Omega$  (unless otherwise noted)

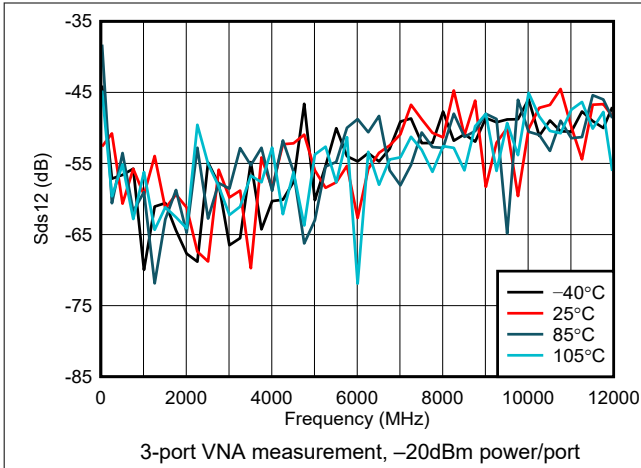

Figure 5-7. Reverse Isolation Across Temperature

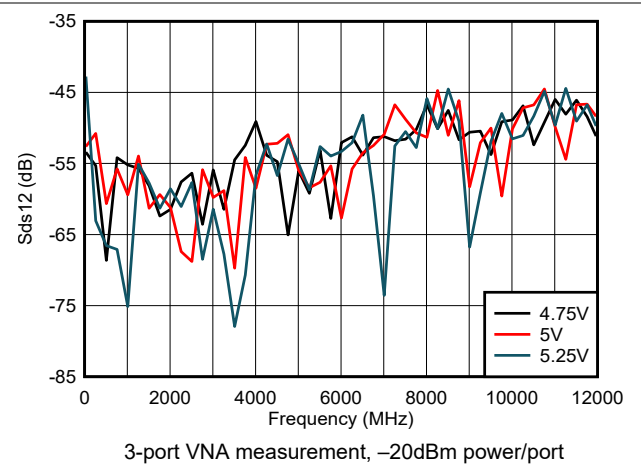

Figure 5-8. Reverse Isolation Across Supply Voltage

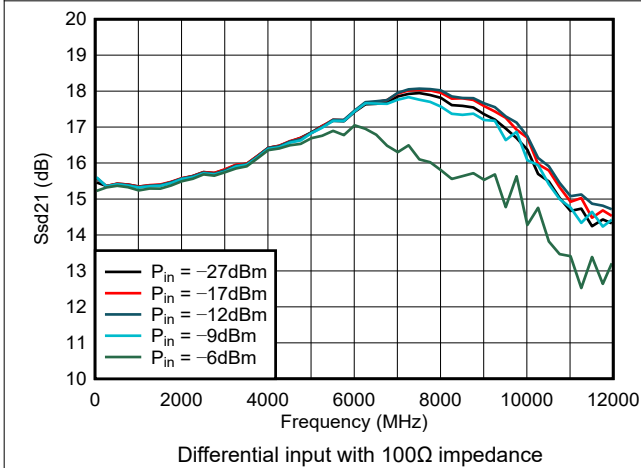

Figure 5-9. Gain Across Input Power

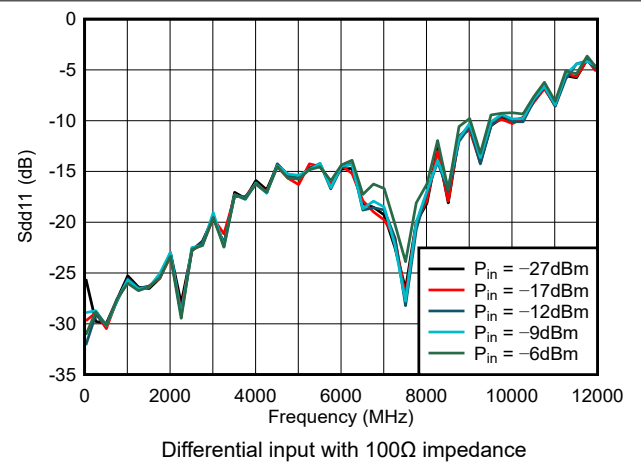

Figure 5-10. Input Return Loss Across Input Power

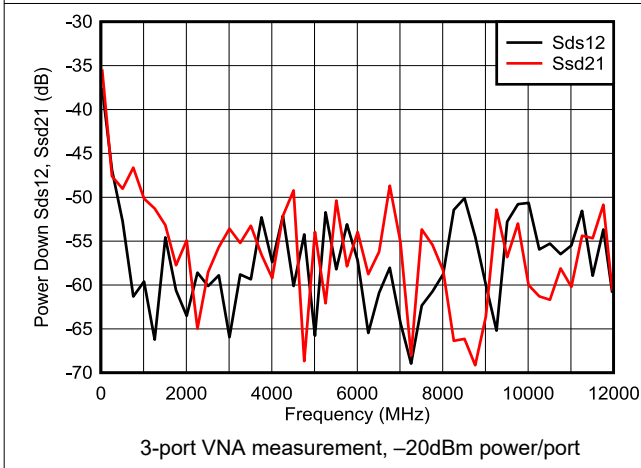

Figure 5-11. Power Down Forward Gain and Reverse Isolation

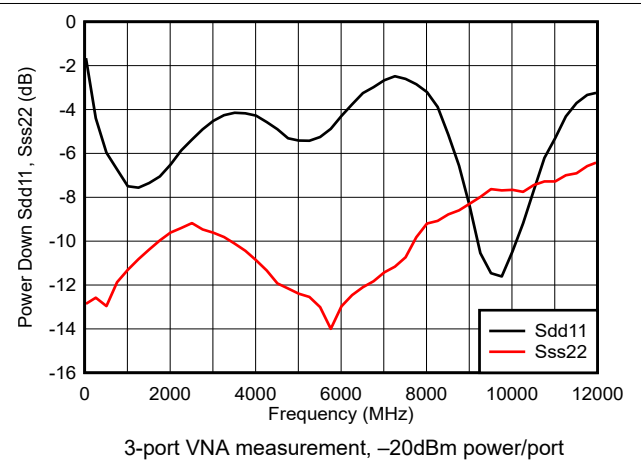
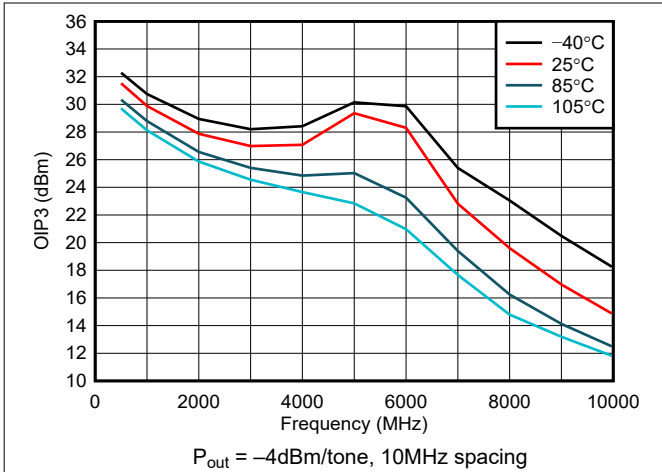

Figure 5-12. Power Down Input and Output Return Loss

### 5.6 Typical Characteristics (continued)

at  $T_A = 25^\circ\text{C}$ , temperature curves specify ambient temperature, single-supply operation with  $V_{DD} = 5\text{V}$ , 100nF ac-coupling capacitors at input and output, differential input with  $R_S = 100\Omega$ , and output with  $R_L = 50\Omega$  (unless otherwise noted)



**Figure 5-13. OIP3 Across Temperature**

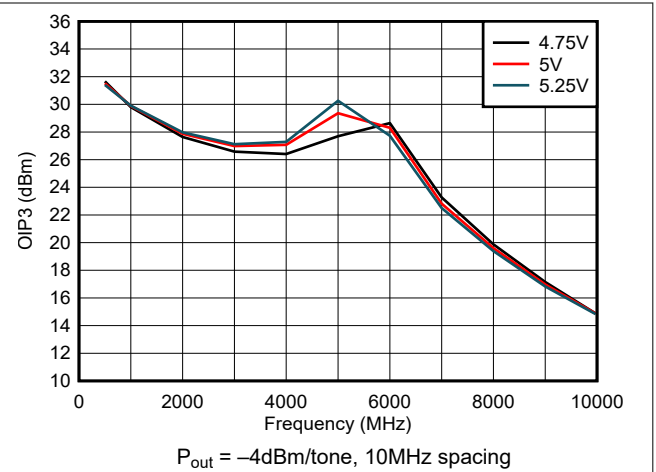

**Figure 5-14. OIP3 Across Supply Voltage**

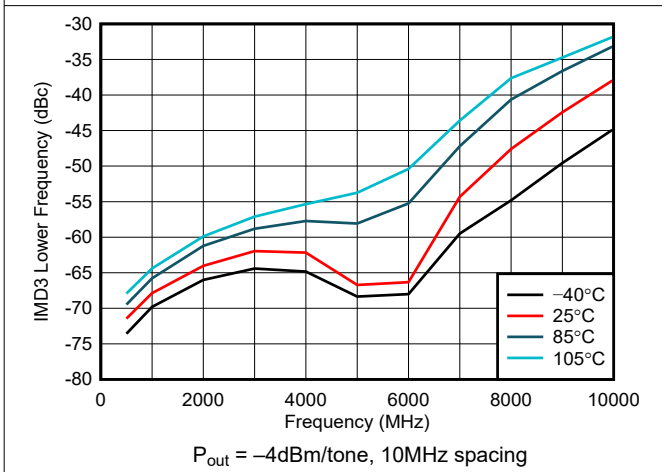

**Figure 5-15. IMD3 Lower Across Temperature**

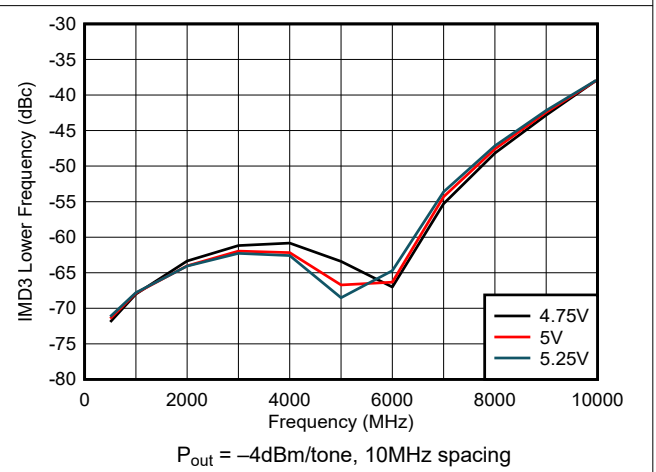

**Figure 5-16. IMD3 Lower Across Supply Voltage**

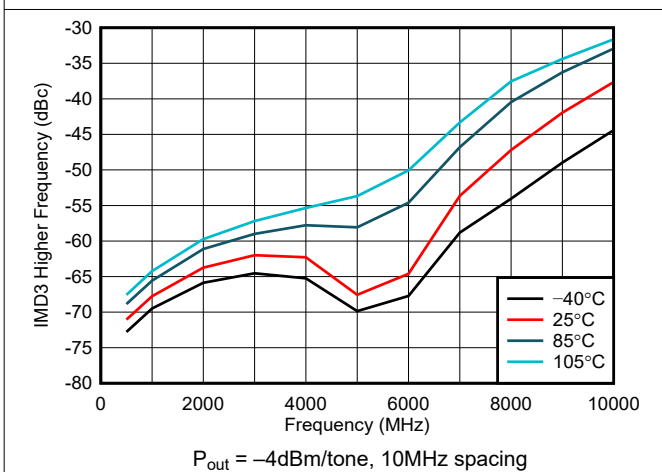

**Figure 5-17. IMD3 Higher Across Temperature**

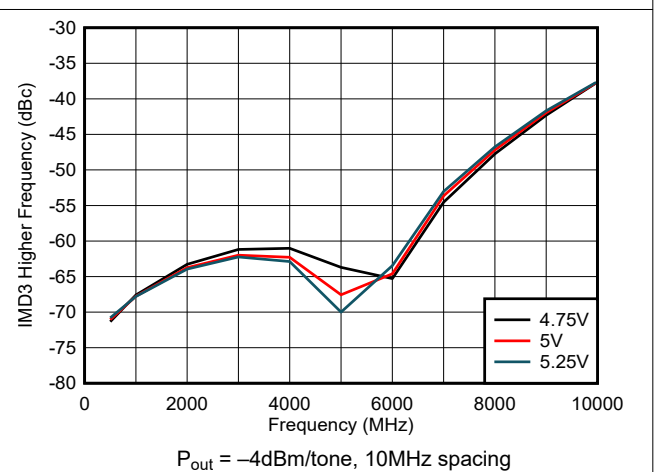

**Figure 5-18. IMD3 Higher Across Supply Voltage**

### 5.6 Typical Characteristics (continued)

at  $T_A = 25^\circ\text{C}$ , temperature curves specify ambient temperature, single-supply operation with  $V_{DD} = 5\text{V}$ , 100nF ac-coupling capacitors at input and output, differential input with  $R_S = 100\Omega$ , and output with  $R_L = 50\Omega$  (unless otherwise noted)

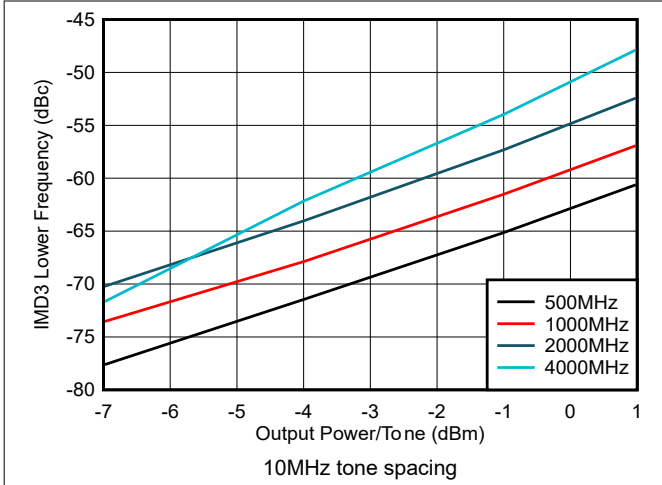

Figure 5-19. IMD3 Lower Across Output Power

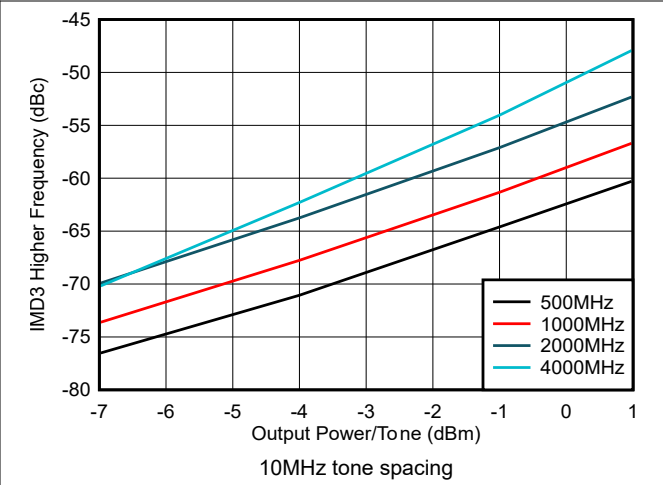

Figure 5-20. IMD3 Higher Across Output Power

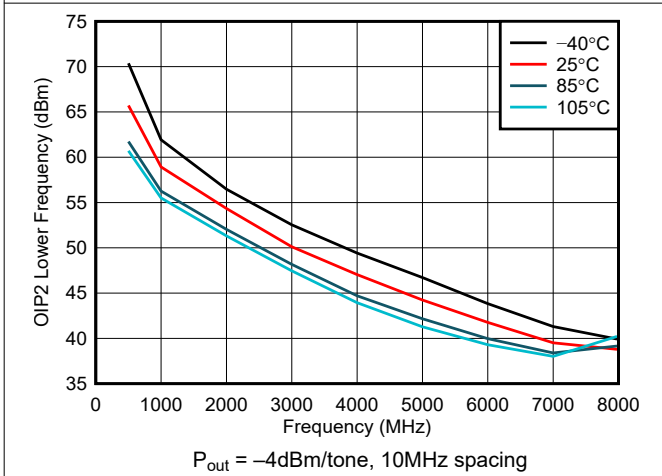

Figure 5-21. OIP2 Lower Across Temperature

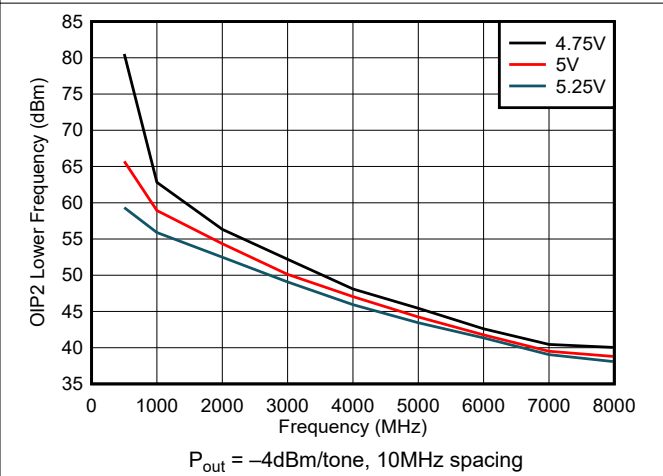

Figure 5-22. OIP2 Lower Across Supply Voltage

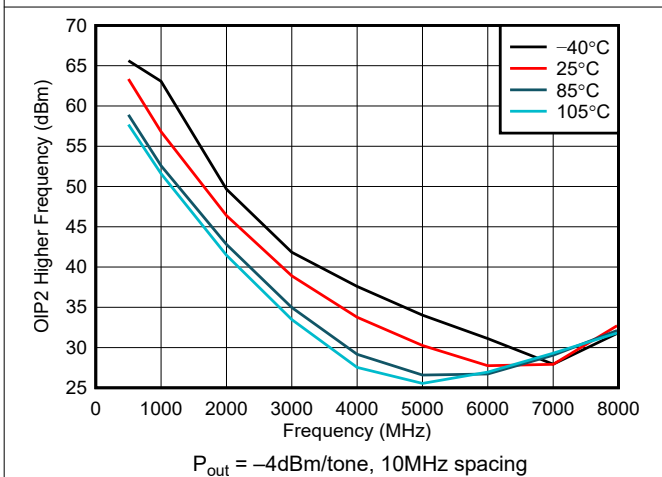

Figure 5-23. OIP2 Higher Across Temperature

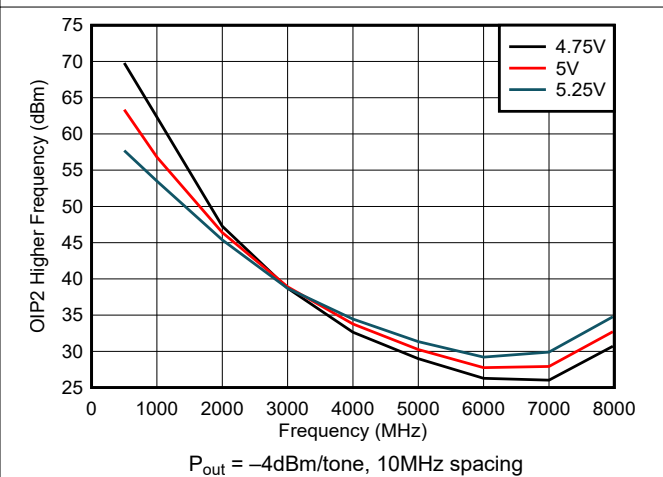
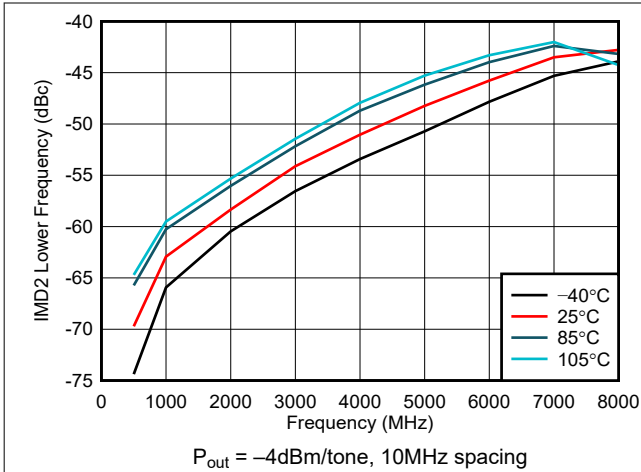

Figure 5-24. OIP2 Higher Across Supply Voltage

### 5.6 Typical Characteristics (continued)

at  $T_A = 25^\circ\text{C}$ , temperature curves specify ambient temperature, single-supply operation with  $V_{DD} = 5\text{V}$ , 100nF ac-coupling capacitors at input and output, differential input with  $R_S = 100\Omega$ , and output with  $R_L = 50\Omega$  (unless otherwise noted)



**Figure 5-25. IMD2 Lower Across Temperature**

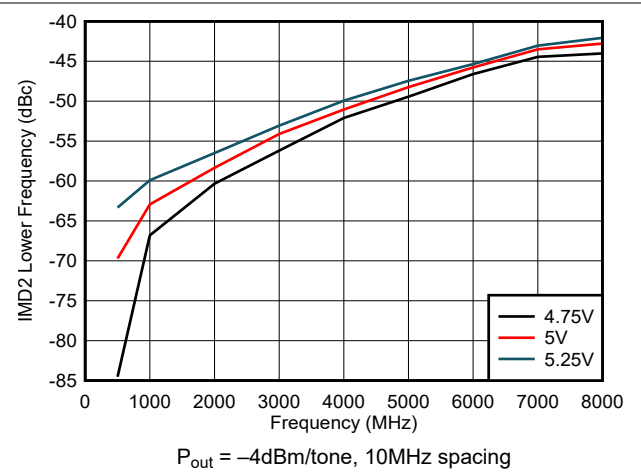

**Figure 5-26. IMD2 Lower Across Supply Voltage**

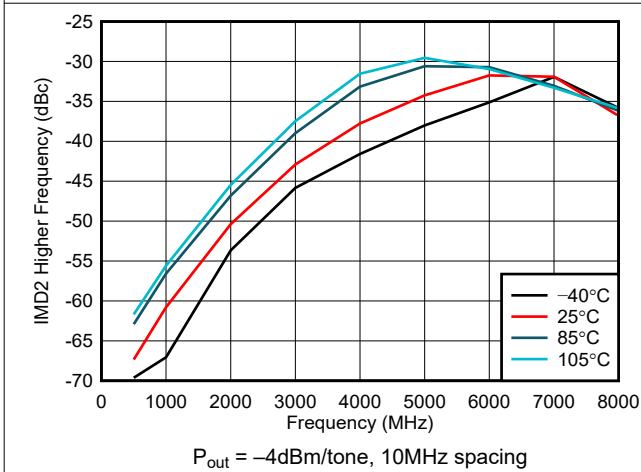

**Figure 5-27. IMD2 Higher Across Temperature**

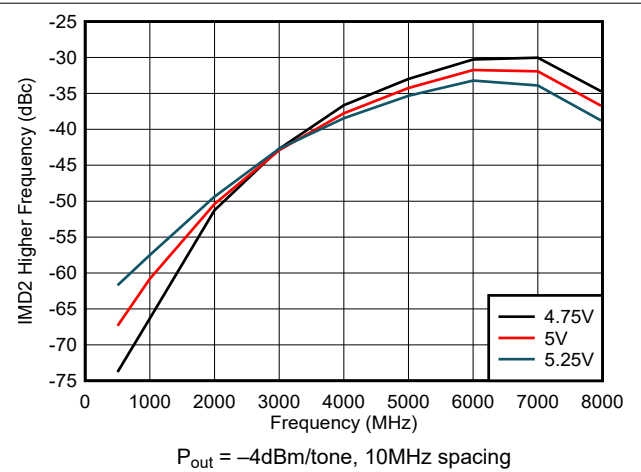

**Figure 5-28. IMD2 Higher Across Supply Voltage**

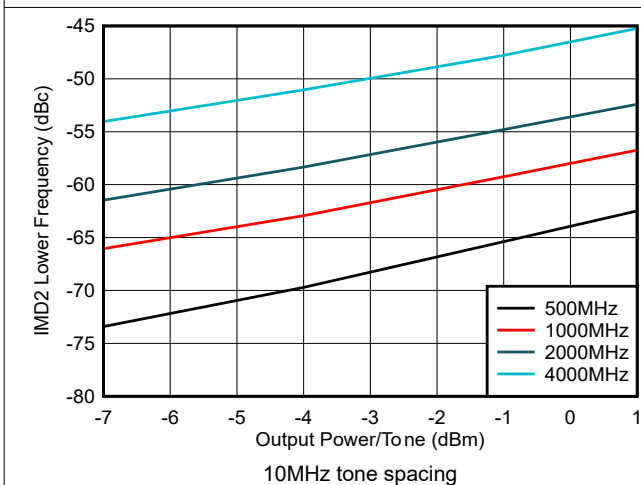

**Figure 5-29. IMD2 Lower Across Output Power**

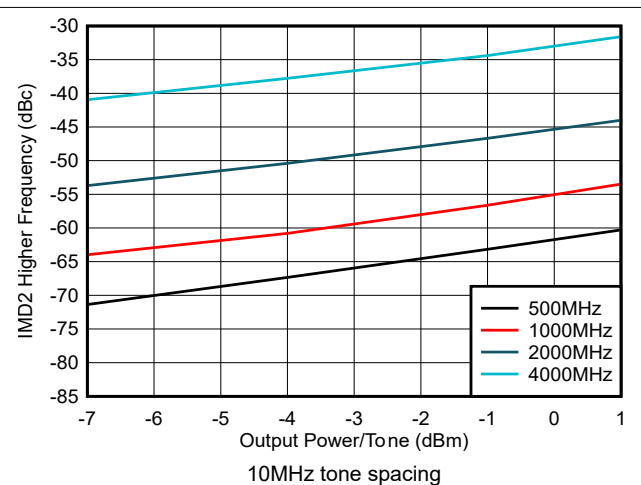

**Figure 5-30. IMD2 Higher Across Output Power**

### 5.6 Typical Characteristics (continued)

at  $T_A = 25^\circ\text{C}$ , temperature curves specify ambient temperature, single-supply operation with  $V_{DD} = 5\text{V}$ , 100nF ac-coupling capacitors at input and output, differential input with  $R_S = 100\Omega$ , and output with  $R_L = 50\Omega$  (unless otherwise noted)

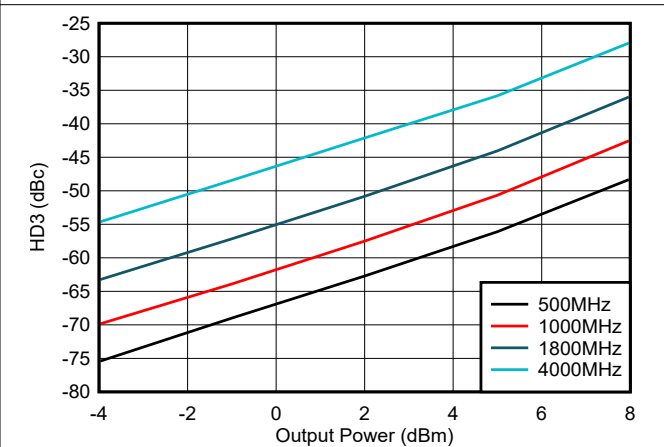
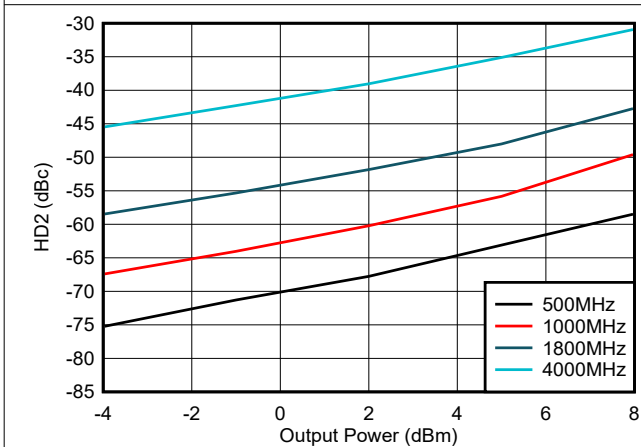
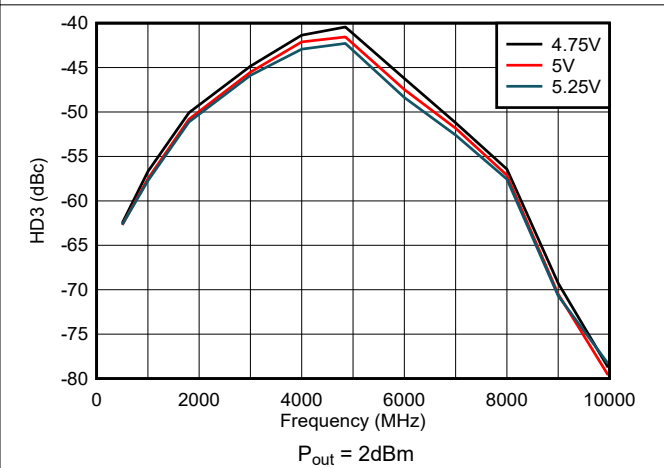
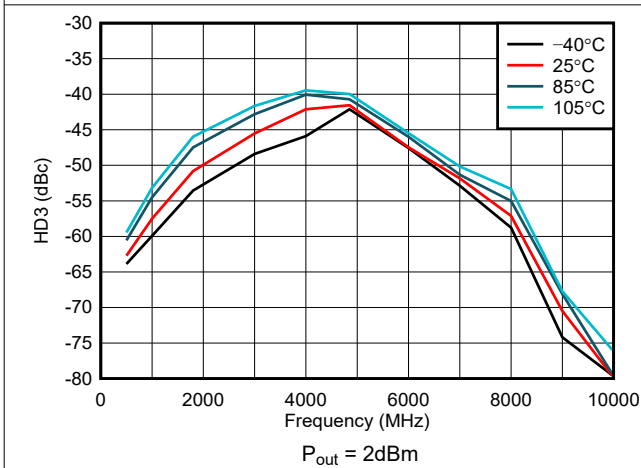
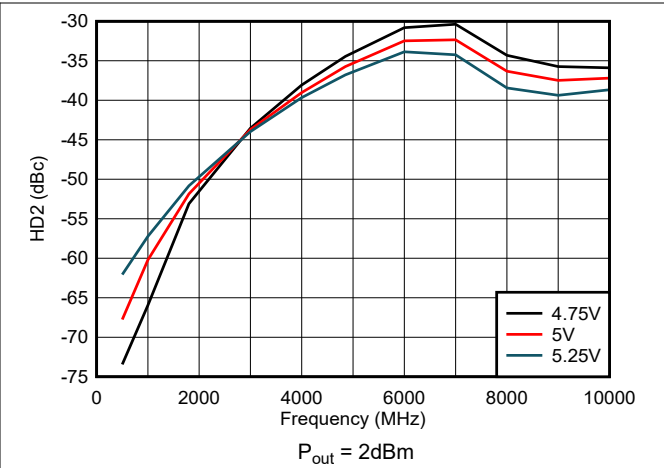
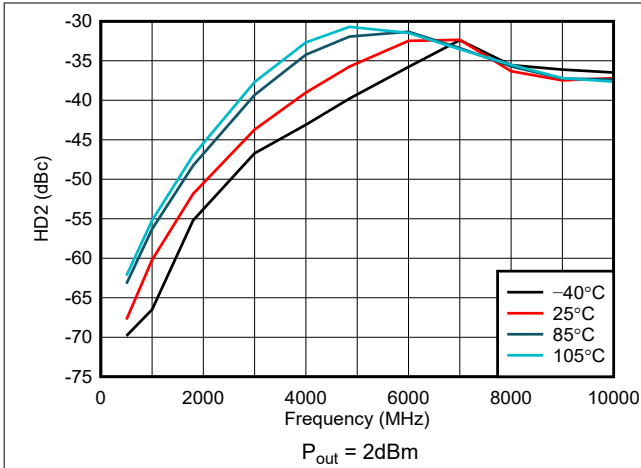

### 5.6 Typical Characteristics (continued)

at  $T_A = 25^\circ\text{C}$ , temperature curves specify ambient temperature, single-supply operation with  $V_{DD} = 5\text{V}$ , 100nF ac-coupling capacitors at input and output, differential input with  $R_S = 100\Omega$ , and output with  $R_L = 50\Omega$  (unless otherwise noted)

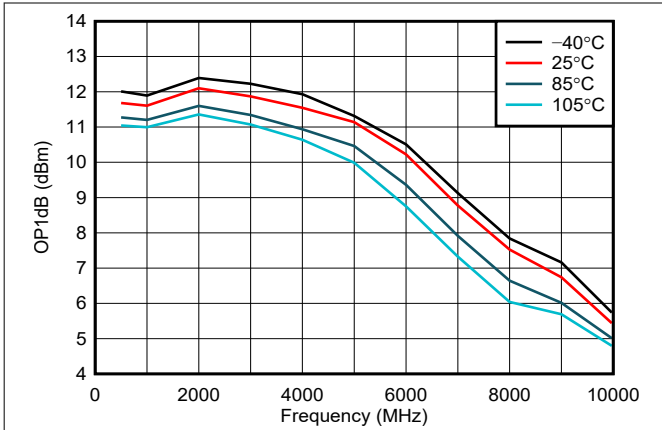

Figure 5-37. OP1dB Across Temperature

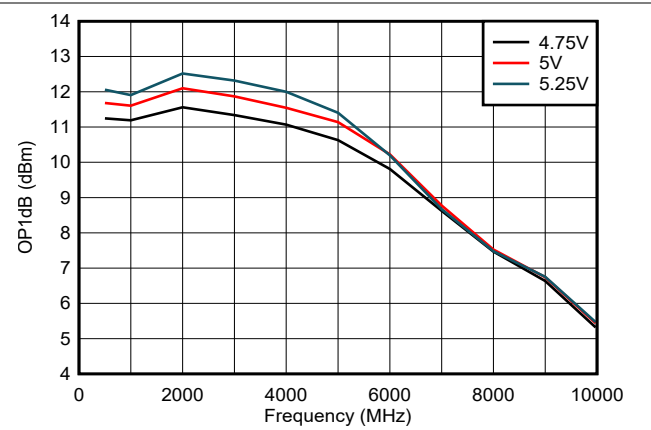

Figure 5-38. OP1dB Across Supply Voltage

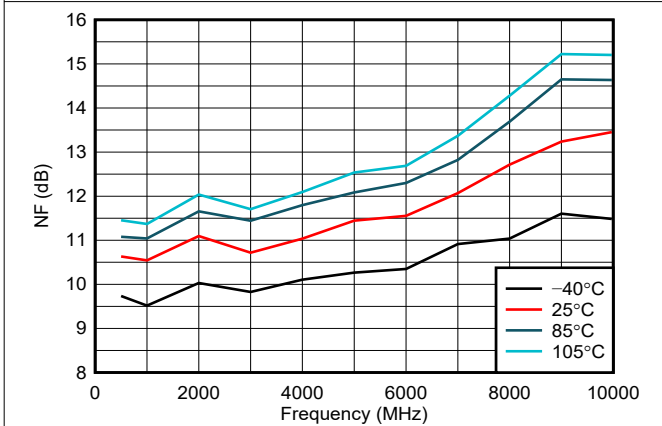

Figure 5-39. NF Across Temperature

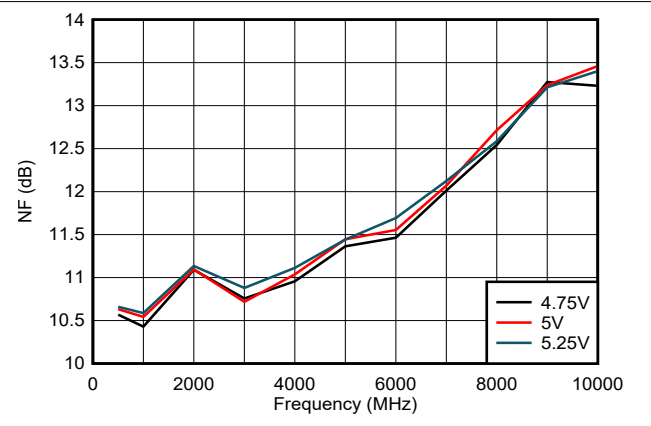

Figure 5-40. NF Across Supply Voltage

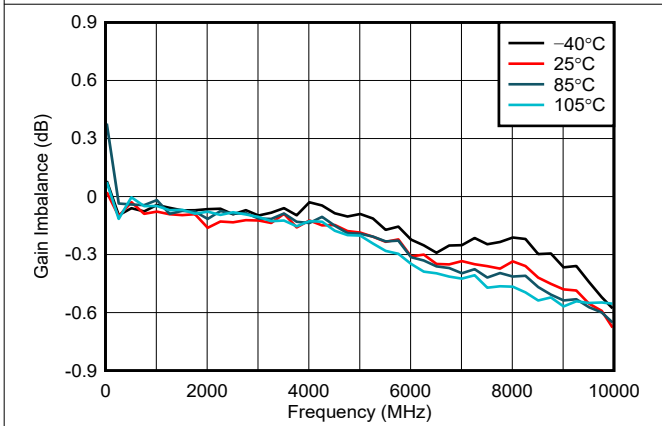

Figure 5-41. Gain Imbalance Across Temperature

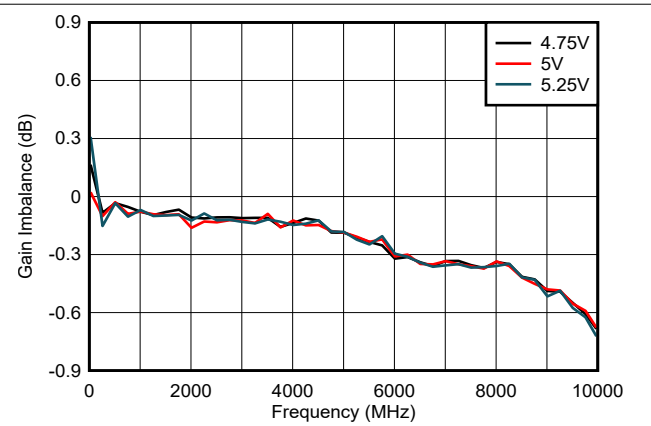

Figure 5-42. Gain Imbalance Across Supply Voltage

### 5.6 Typical Characteristics (continued)

at  $T_A = 25^\circ\text{C}$ , temperature curves specify ambient temperature, single-supply operation with  $V_{DD} = 5\text{V}$ , 100nF ac-coupling capacitors at input and output, differential input with  $R_S = 100\Omega$ , and output with  $R_L = 50\Omega$  (unless otherwise noted)

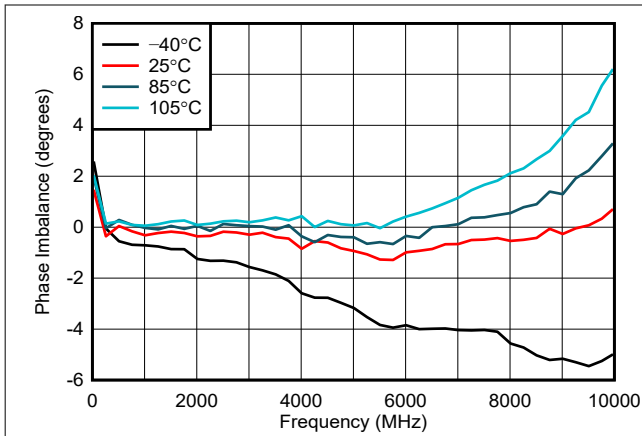

Figure 5-43. Phase Imbalance Across Temperature

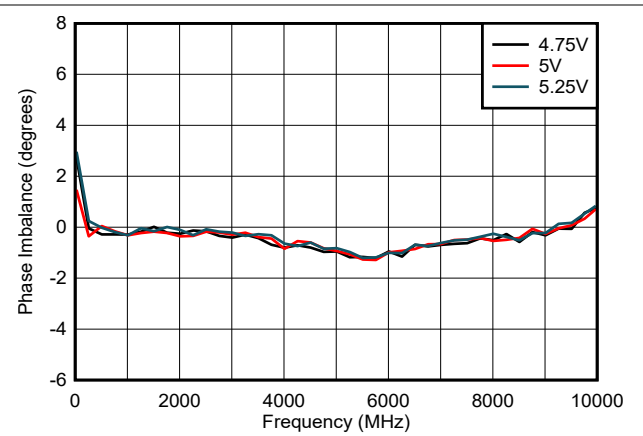

Figure 5-44. Phase Imbalance Across Supply Voltage

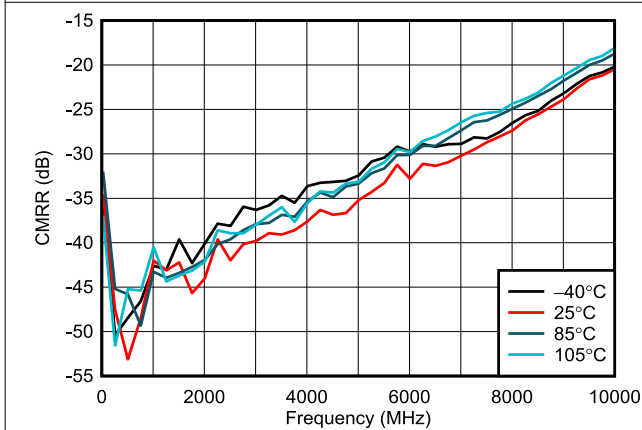

Figure 5-45. CMRR Across Temperature

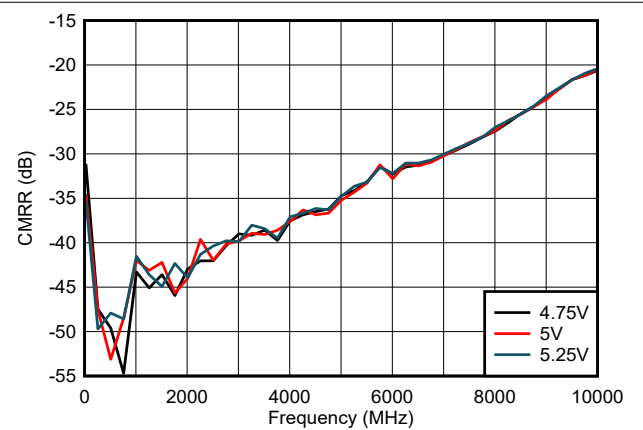
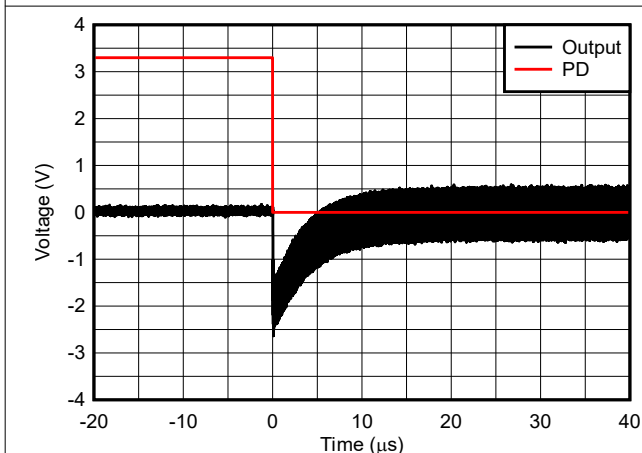
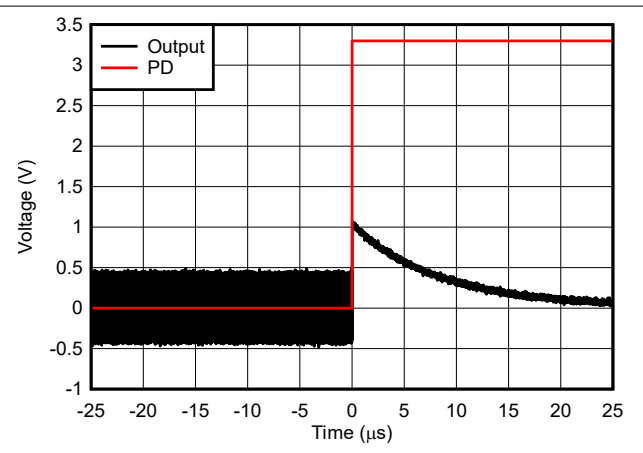

Figure 5-46. CMRR Across Supply Voltage



f = 500MHz, 100nF ac-coupling capacitors

Figure 5-47. Turn On Time



f = 500MHz, 100nF ac-coupling capacitors

Figure 5-48. Turn Off Time

## 5.6 Typical Characteristics (continued)

at  $T_A = 25^\circ\text{C}$ , temperature curves specify ambient temperature, single-supply operation with  $V_{DD} = 5\text{V}$ , 100nF ac-coupling capacitors at input and output, differential input with  $R_S = 100\Omega$ , and output with  $R_L = 50\Omega$  (unless otherwise noted)

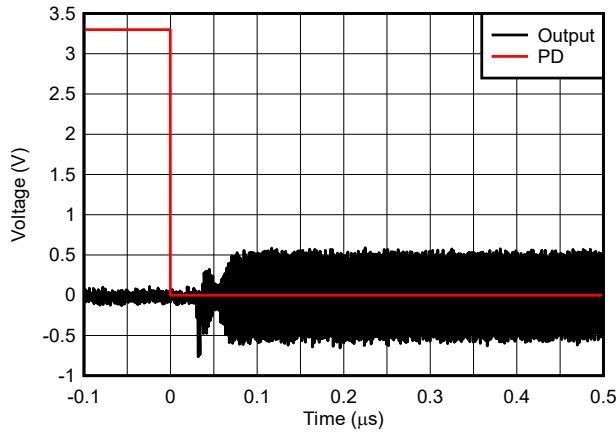

$f = 500\text{MHz}$ , 22pF ac-coupling capacitors

**Figure 5-49. Turn On Time**

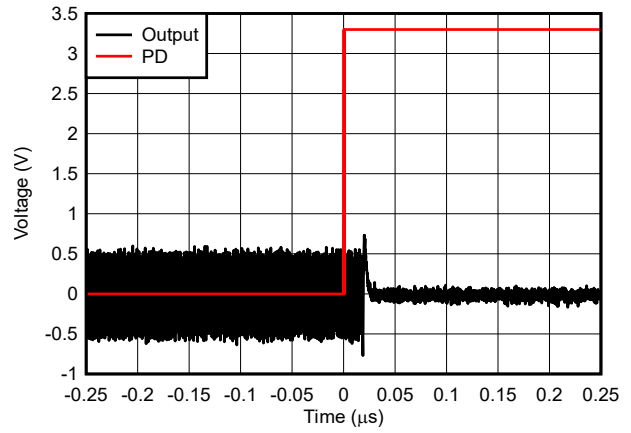

$f = 500\text{MHz}$ , 22pF ac-coupling capacitors

**Figure 5-50. Turn Off Time**

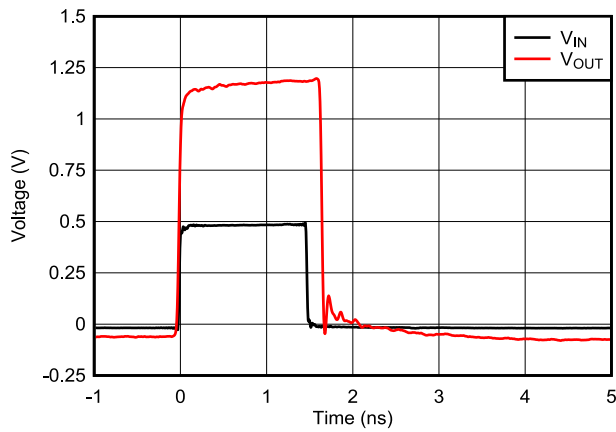

0.5V input pulse

**Figure 5-51. Overload Recovery**

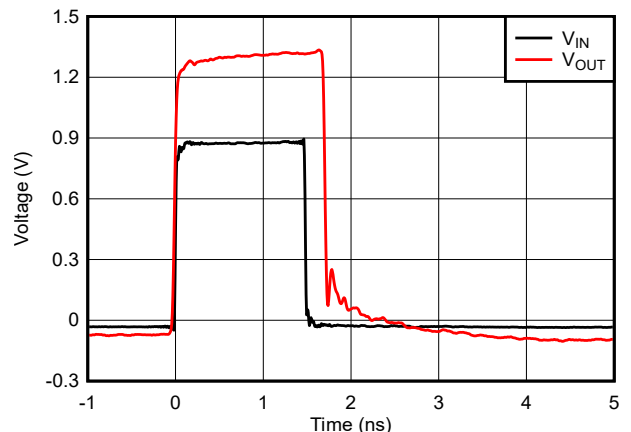

0.9V input pulse

**Figure 5-52. Overload Recovery**

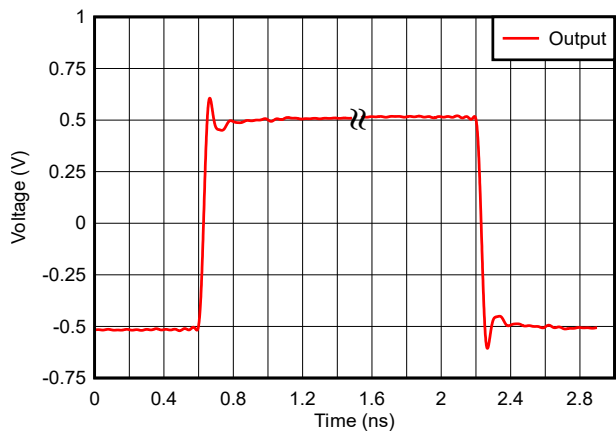

**Figure 5-53. Step Response**

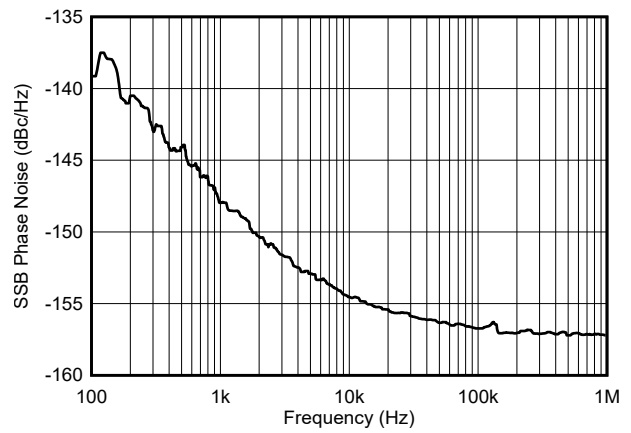

$f = 1\text{GHz}$ ,  $P_{out} = 6\text{dBm}$

**Figure 5-54. Additive (Residual) Phase Noise**

## 5.6 Typical Characteristics (continued)

at  $T_A = 25^\circ\text{C}$ , temperature curves specify ambient temperature, single-supply operation with  $V_{DD} = 5\text{V}$ , 100nF ac-coupling capacitors at input and output, differential input with  $R_S = 100\Omega$ , and output with  $R_L = 50\Omega$  (unless otherwise noted)

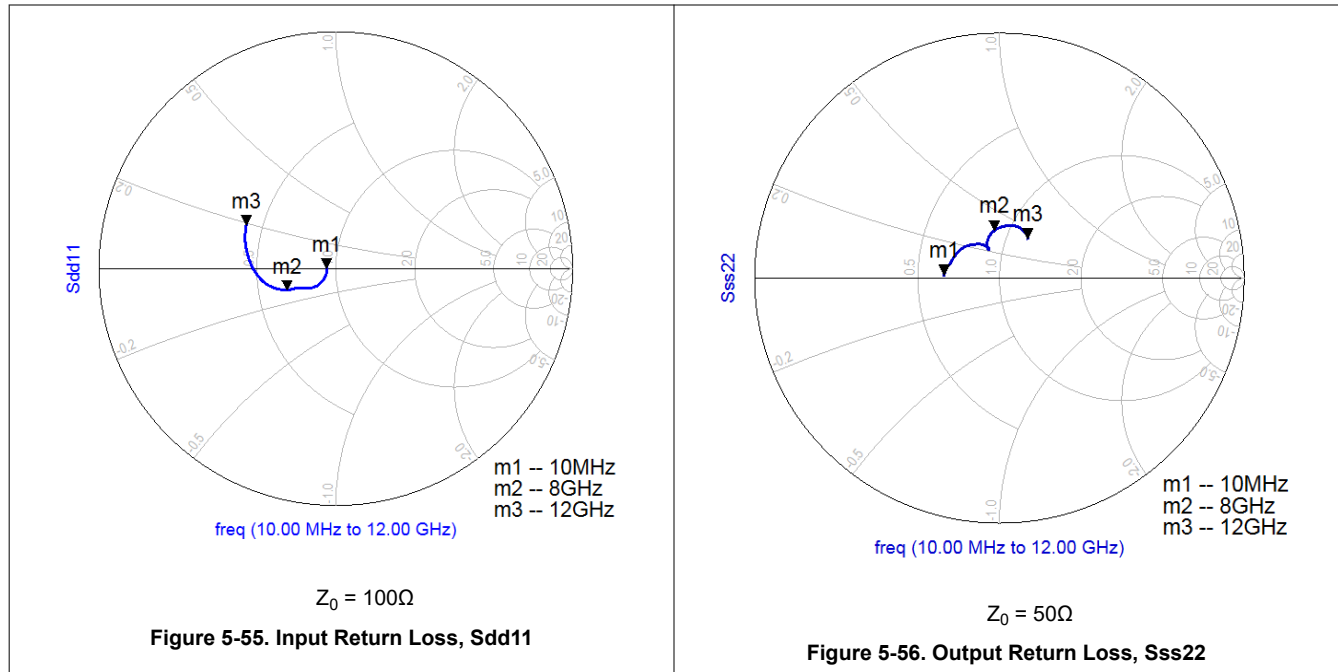

## 6 Detailed Description

### 6.1 Overview

The TRF1108 is a very high-performance differential-to-single-ended (D2S) amplifier optimized for radio frequency (RF) and intermediate frequency (IF) applications with signal bandwidths up to 8GHz. The device is excellent choice for conversion of differential output of an RF DAC to a single-ended output. The device has a two-stage architecture and provides approximately 15.5dB to 18dB of gain (1GHz to 8GHz). The on-chip matching components simplify printed-circuit-board (PCB) implementation and provide the highest performance over the usable bandwidth. A power-down feature is also available for power savings.

### 6.2 Functional Block Diagram

The following figure shows the functional block diagram of TRF1108. The differential inputs are matched to 100Ω, and single ended output is matched to 50Ω. The input common-mode voltage is internally set, simplifying ac-coupled applications.

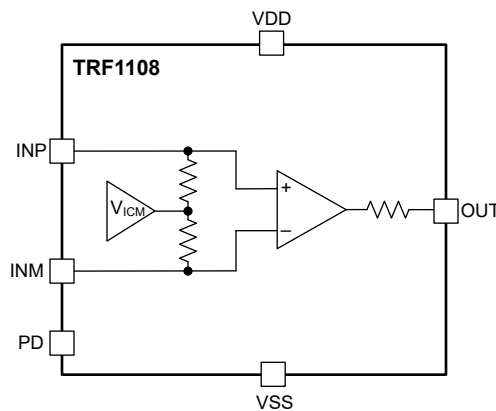

### 6.3 Feature Description

#### 6.3.1 AC-Coupled Configuration

Figure 6-1 shows the TRF1108 in an ac-coupled configuration with single 5V supply operation. The input common-mode voltage is internally set, simplifying biasing of the device. The value of the ac-coupling capacitors at the inputs and output set the lower cutoff frequency for the gain.

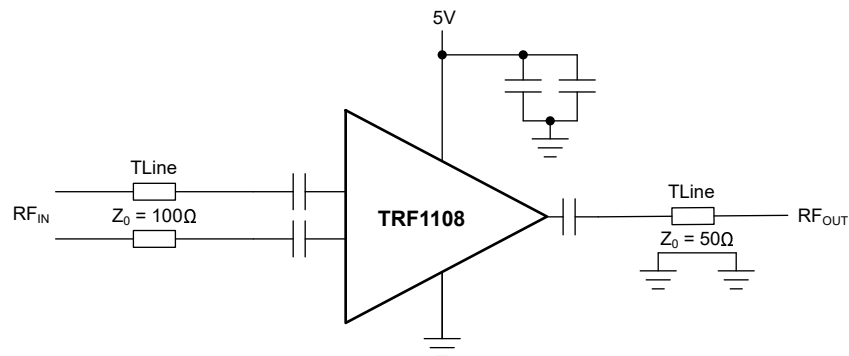
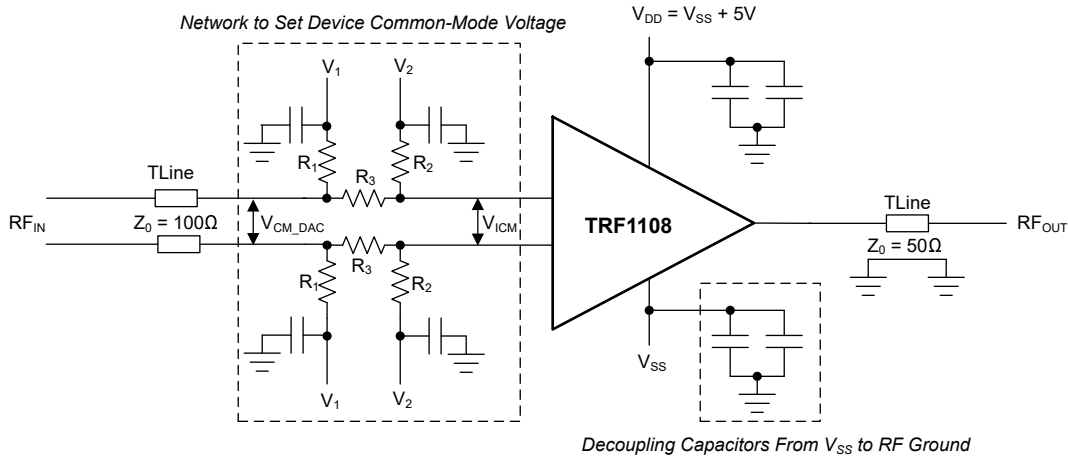

Figure 6-1. The TRF1108 Used in an AC-Coupled Configuration

### 6.3.2 DC-Coupled Configuration

Figure 6-2 shows that the TRF1108 can be dc-coupled with the help of an application circuit. Operate on  $V_{DD} = +1.68\text{V}$  and  $V_{SS} = -3.32\text{V}$  supplies to set the output dc-bias level to  $0\text{V}$ . Externally set the input common-mode voltage to  $-1.98\text{V}$  to bias the device. A resistive level shifter network, along with external bias voltages, translates output common-mode of the DAC to input common-mode of the amplifier.



**Figure 6-2. The TRF1108 Used in a DC-Coupled Configuration**

## 6.4 Device Functional Modes

TRF1108 has two functional modes: active and power-down. These functional modes are controlled by the PD pin as described in the next section.

### 6.4.1 Power-Down Mode

The device features a power-down option. The PD pin is used to power down the amplifier. This pin supports both 1.8V and 3.3V digital logic, and is referenced to  $V_{SS}$ . A logic 1 turns the device off and places the device into a low-quiescent-current state.

## 7 Application and Implementation

### Note

Information in the following applications sections is not part of the TI component specification, and TI does not warrant its accuracy or completeness. TI's customers are responsible for determining suitability of components for their purposes, as well as validating and testing their design implementation to confirm system functionality.

### 7.1 Application Information

#### 7.1.1 Thermal Considerations

The TRF1108 is packaged in a 2mm × 2mm WQFN-FCRLF package that has excellent thermal properties. Connect the thermal pad under the chip to a wide VSS plane. Short the VSS plane to the other VSS pins of the chip at four corners, if possible, to allow heat propagation to the top layer of PCB. Use a thermal via to connect the thermal pad plane on the top layer of PCB to inner layer VSS planes to allow heat dissipation to the inner layers. See also [Section 7.4](#).

### 7.2 Typical Application

#### 7.2.1 RF DAC Buffer Amplifier

A common application of the TRF1108 is to function as a buffer amplifier for an RF DAC, such as the [DAC39RF10](#) or [AFE7950](#), which have differential outputs. Conventionally, passive baluns are used to interface with RF DACs as a result of the low-availability of high-bandwidth, linear amplifiers that support differential-to-single-ended conversion. The TRF1108 is a differential-to-single-ended amplifier that has excellent gain and phase imbalance, input and output return loss, and exceeds the performance of bulky and expensive passive baluns for D2S applications. The TRF1108 integrates the functionality of a wide-band passive balun and gain-block in a single 2mm × 2mm package, reducing PCB area for high-channel-count systems.

The following figure shows the schematic, where the TRF1108 is used as a D2S DAC buffer amplifier.

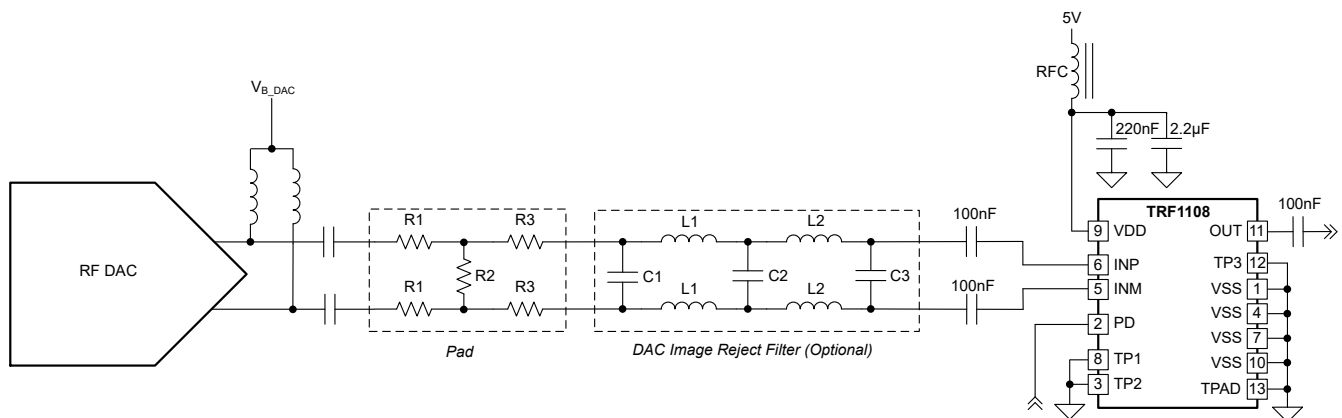

Figure 7-1. Interfacing With an RF DAC

### 7.2.1.1 Design Requirements

The TRF1108 is required to convert differential output of an RF DAC to single-ended output, over a wide bandwidth of 10MHz to 4GHz, delivering 6.2dBm power at 1GHz into a 50Ω load with good output return loss.

**Table 7-1. Design Parameters**

| PARAMETER                             | VALUE         |
|---------------------------------------|---------------|
| RF signal frequency range             | 10MHz to 4GHz |
| DAC sampling rate                     | 10.24GSPS     |
| Output power at 1GHz                  | 6.2dBm        |
| Output return loss, S <sub>ss22</sub> | -12dB         |

### 7.2.1.2 Detailed Design Procedure

Select an RF DAC such as the DAC39RF10 for this application because this DAC supports sampling at 10.24GSPS and the required RF signal frequency range of 4GHz. The DAC39RF10 outputs a signal level of -0.2dBm at 1GHz when operating at -1dBFS in the DES2X, 20.5mA current mode. The TRF1108 has a gain of 15.4dB and OP1dB of 12dBm at 1GHz; therefore, add approximately 9dB pad at the output of the DAC to get 6.2dBm output power. The pad loss can be reduced to 3dB if the DAC is run at -7dBFS in the 20.5mA current mode, or -1dBFS in the 10mA current mode. A 5GHz low-pass filter can optionally be added to reject the DAC images in the second Nyquist zone. From the TRF1108 specifications, the device meets the design requirement of output return loss. [Table 7-2](#) shows the component values for attenuator and low-pass filter for the design.

**Table 7-2. Component Values for Attenuator and Low-Pass Filter for the DAC39RF10 Interface**

| SECTION         | DESIGNATOR | TYPE      | VALUE |
|-----------------|------------|-----------|-------|
| Pad             | R1         | Resistor  | 22Ω   |
| Pad             | R2         | Resistor  | 94Ω   |
| Pad             | R3         | Resistor  | 22Ω   |
| Low-pass filter | C1         | Capacitor | 0.5pF |
| Low-pass filter | C2         | Capacitor | 0.8pF |
| Low-pass filter | C3         | Capacitor | 0.5pF |
| Low-pass filter | L1         | Inductor  | 2nH   |
| Low-pass filter | L2         | Inductor  | 2nH   |

### 7.2.1.3 Application Curve

[Figure 7-2](#) shows the output response measured on a spectrum analyzer for the design in the previous section. Evaluate the design using the [TRF1108-DAC39RFEVM](#) that can be ordered from [www.ti.com](#).

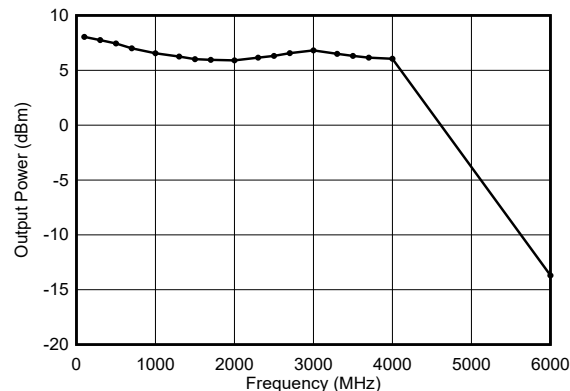

**Figure 7-2. Output Response Including Filter**

## 7.3 Power Supply Recommendations

### 7.3.1 Single-Supply Operation

The TRF1108 supports single 5V supply operation for ac-coupled applications. Supply decoupling is critical to high-frequency performance. Typically, two or three capacitors are used for VDD supply decoupling. Use a 220nF, small-form-factor, 0201-size component placed closest to the VDD pin of the device. Use 0402-size, 2.2 $\mu$ F bulk decoupling capacitors placed next to the small capacitor. A ferrite bead can be further used to filter power-supply noise. For single-supply operation, short VSS to RF ground; a separate VSS plane is not needed. See also [Section 7.4](#).

### 7.3.2 Dual-Supply Operation

The TRF1108 supports dual-supply operation for dc-coupled applications. Follow the recommendations in [Section 7.3.1](#) for VDD to VSS decoupling. For VSS to RF ground decoupling, use 0201-size, 100nF decoupling capacitors at multiple places near the device. Use 0402-size, 2.2 $\mu$ F bulk decoupling capacitors further away where area is available. See also [Section 7.4](#).

## 7.4 Layout

### 7.4.1 Layout Guidelines

The TRF1108 is a wide-band feedback amplifier with approximately 15.5dB to 18dB of gain (1GHz to 8GHz). When designing with a wide-band RF amplifier with relatively high gain, follow these printed-circuit-board (PCB) layout guidelines to maintain stability and optimized performance:

- Use a multilayer board to maintain signal and power integrity, and thermal performance. The figures in the next section show an example of a good layout.
- Route the RF input and output lines as grounded coplanar waveguide (GCPW) lines. For the second layer, use a continuous ground polygon below the RF traces, and continuous VSS polygon below the amplifier area.
- Match the input differential lines in length to minimize phase imbalance.
- Use small-footprint, passive components wherever possible.
- Connect the ground and VSS planes on the top and internal layers with well-stitched vias.
- Place a thermal via under the device that connects the top thermal pad with VSS planes in the inner layers of the PCB. Also, connect the thermal pad to the top layer VSS plane through the VSS pins for improved heat dissipation.

### 7.4.2 Layout Example

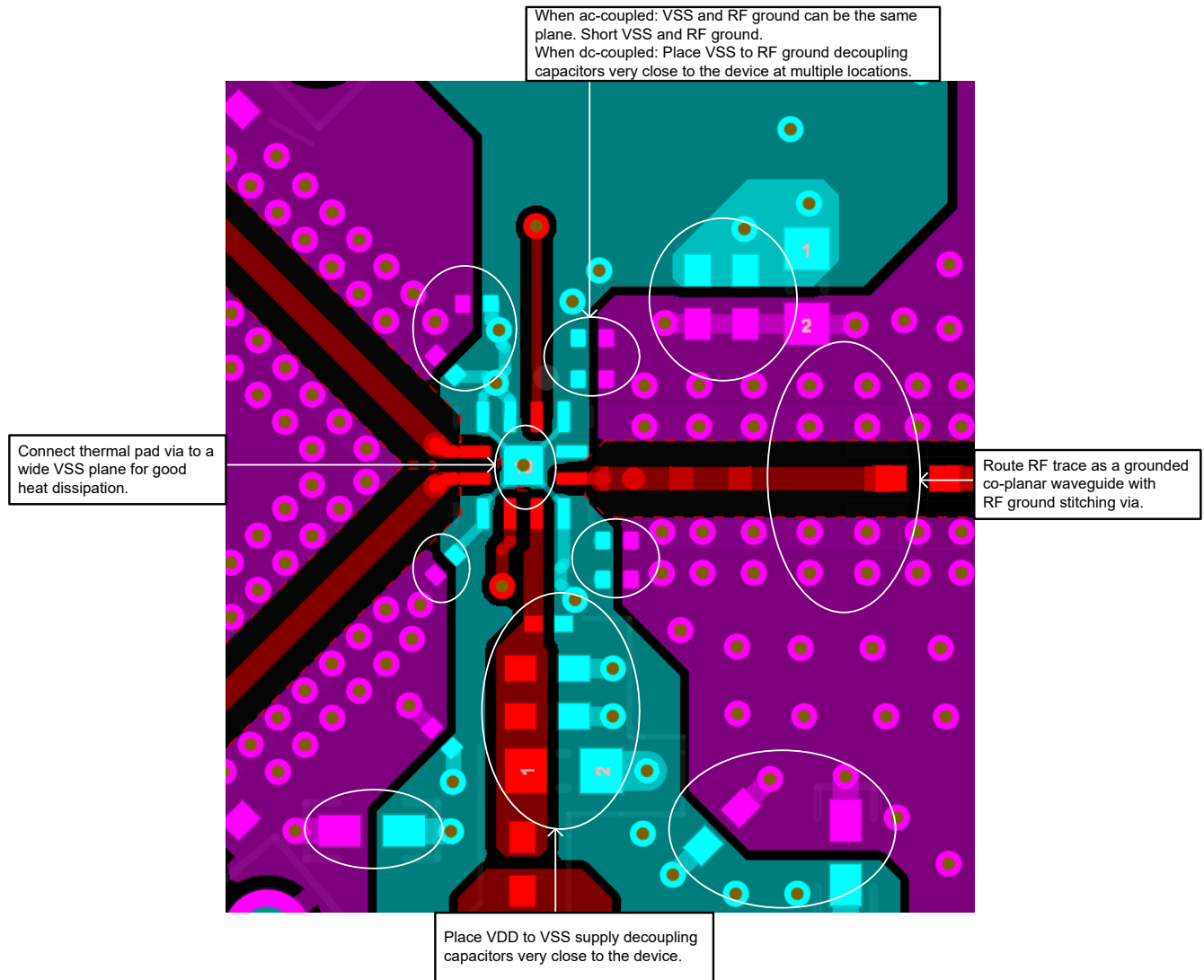

**Figure 7-3. Layout Example: Placement and Top Layer**

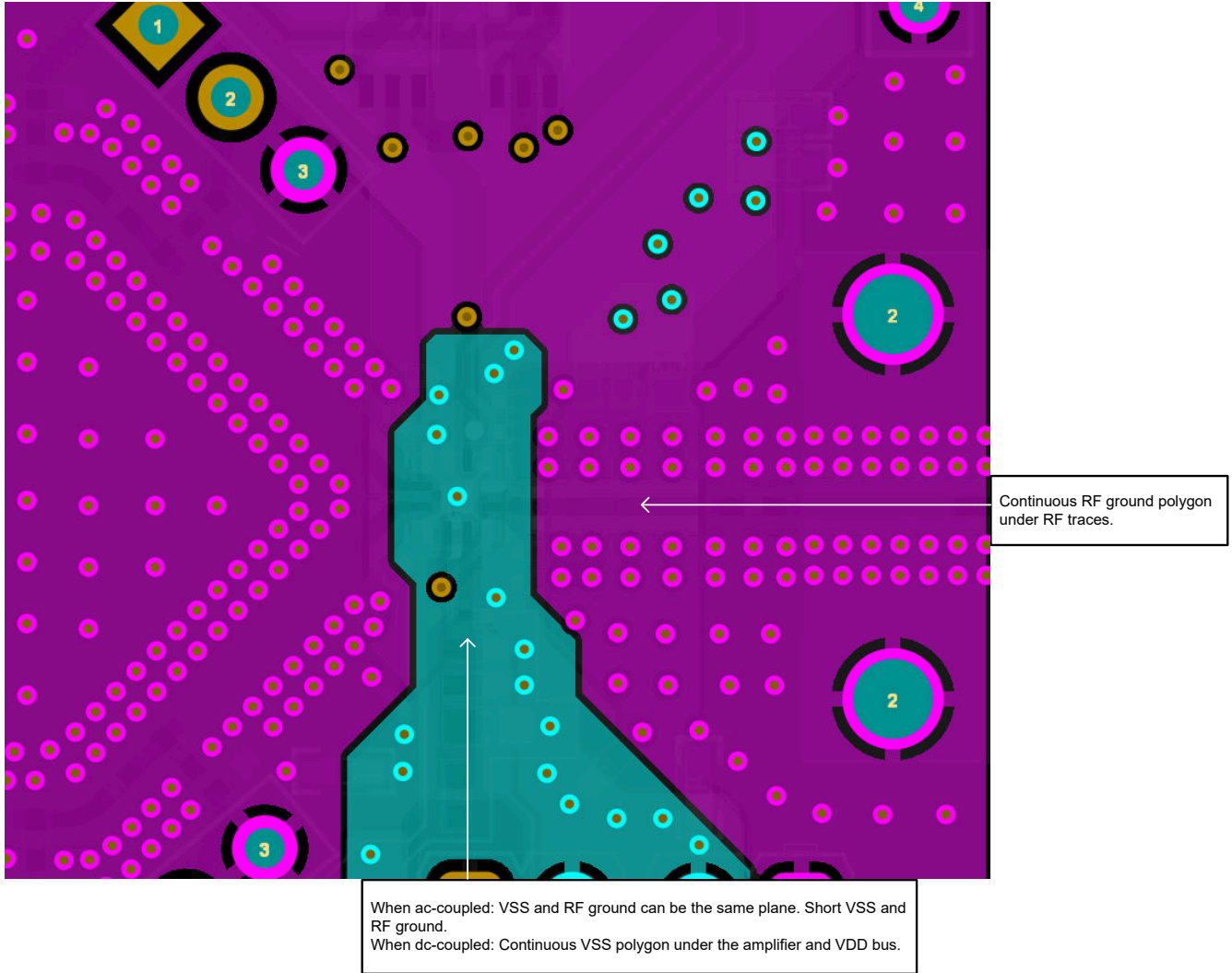

**Figure 7-4. Layout Example: Second Layer**

Evaluate the TRF1108 using the [TRF1108 EVM board](#) that can be ordered from [www.ti.com](#). Additional information about the evaluation board construction and test setup is given in the [TRF1108 Evaluation Module User's Guide](#).

## 8 Device and Documentation Support

### 8.1 Documentation Support

#### 8.1.1 Related Documentation

For related documentation see the following:

Texas Instruments, [TRF1108 Evaluation Module User's Guide](#)

### 8.2 Receiving Notification of Documentation Updates

To receive notification of documentation updates, navigate to the device product folder on [ti.com](#). Click on *Notifications* to register and receive a weekly digest of any product information that has changed. For change details, review the revision history included in any revised document.

### 8.3 Support Resources

[TI E2E™ support forums](#) are an engineer's go-to source for fast, verified answers and design help — straight from the experts. Search existing answers or ask your own question to get the quick design help you need.

Linked content is provided "AS IS" by the respective contributors. They do not constitute TI specifications and do not necessarily reflect TI's views; see TI's [Terms of Use](#).

### 8.4 Trademarks

TI E2E™ is a trademark of Texas Instruments.

All trademarks are the property of their respective owners.

### 8.5 Electrostatic Discharge Caution



This integrated circuit can be damaged by ESD. Texas Instruments recommends that all integrated circuits be handled with appropriate precautions. Failure to observe proper handling and installation procedures can cause damage.

ESD damage can range from subtle performance degradation to complete device failure. Precision integrated circuits may be more susceptible to damage because very small parametric changes could cause the device not to meet its published specifications.

### 8.6 Glossary

[TI Glossary](#) This glossary lists and explains terms, acronyms, and definitions.

## 9 Revision History

NOTE: Page numbers for previous revisions may differ from page numbers in the current version.

| Changes from Revision * (July 2024) to Revision A (November 2024)                              | Page |
|--|------|
| • Changed document status from advanced information (preview) to production data (active)..... | 1    |

## 10 Mechanical, Packaging, and Orderable Information

The following pages include mechanical, packaging, and orderable information. This information is the most current data available for the designated devices. This data is subject to change without notice and revision of this document. For browser-based versions of this data sheet, refer to the left-hand navigation.

**PACKAGING INFORMATION**

| Orderable part number       | Status<br>(1) | Material type<br>(2) | Package   Pins     | Package qty   Carrier | RoHS<br>(3) | Lead finish/<br>Ball material<br>(4) | MSL rating/<br>Peak reflow<br>(5) | Op temp (°C) | Part marking<br>(6) |
|-----------------------------|---------------|----------------------|--------------------|-----------------------|-------------|--------------------------------------|-----------------------------------|--------------|---------------------|
| <a href="#">TRF1108RPVR</a> | Active        | Production           | WQFN-HR (RPV)   12 | 3000   LARGE T&R      | Yes         | NIPDAU                               | Level-2-260C-1 YEAR               | -40 to 105   | 1108                |
| TRF1108RPVR.B               | Active        | Production           | WQFN-HR (RPV)   12 | 3000   LARGE T&R      | Yes         | NIPDAU                               | Level-2-260C-1 YEAR               | -40 to 105   | 1108                |
| TRF1108RPVRG4               | Active        | Production           | WQFN-HR (RPV)   12 | 3000   LARGE T&R      | Yes         | NIPDAU                               | Level-2-260C-1 YEAR               | -40 to 105   | 1108                |
| TRF1108RPVRG4.B             | Active        | Production           | WQFN-HR (RPV)   12 | 3000   LARGE T&R      | Yes         | NIPDAU                               | Level-2-260C-1 YEAR               | -40 to 105   | 1108                |

(1) **Status:** For more details on status, see our [product life cycle](#).

(2) **Material type:** When designated, preproduction parts are prototypes/experimental devices, and are not yet approved or released for full production. Testing and final process, including without limitation quality assurance, reliability performance testing, and/or process qualification, may not yet be complete, and this item is subject to further changes or possible discontinuation. If available for ordering, purchases will be subject to an additional waiver at checkout, and are intended for early internal evaluation purposes only. These items are sold without warranties of any kind.

(3) **RoHS values:** Yes, No, RoHS Exempt. See the [TI RoHS Statement](#) for additional information and value definition.

(4) **Lead finish/Ball material:** Parts may have multiple material finish options. Finish options are separated by a vertical ruled line. Lead finish/Ball material values may wrap to two lines if the finish value exceeds the maximum column width.

(5) **MSL rating/Peak reflow:** The moisture sensitivity level ratings and peak solder (reflow) temperatures. In the event that a part has multiple moisture sensitivity ratings, only the lowest level per JEDEC standards is shown. Refer to the shipping label for the actual reflow temperature that will be used to mount the part to the printed circuit board.

(6) **Part marking:** There may be an additional marking, which relates to the logo, the lot trace code information, or the environmental category of the part.

Multiple part markings will be inside parentheses. Only one part marking contained in parentheses and separated by a "~" will appear on a part. If a line is indented then it is a continuation of the previous line and the two combined represent the entire part marking for that device.

**Important Information and Disclaimer:** The information provided on this page represents TI's knowledge and belief as of the date that it is provided. TI bases its knowledge and belief on information provided by third parties, and makes no representation or warranty as to the accuracy of such information. Efforts are underway to better integrate information from third parties. TI has taken and continues to take reasonable steps to provide representative and accurate information but may not have conducted destructive testing or chemical analysis on incoming materials and chemicals. TI and TI suppliers consider certain information to be proprietary, and thus CAS numbers and other limited information may not be available for release.

In no event shall TI's liability arising out of such information exceed the total purchase price of the TI part(s) at issue in this document sold by TI to Customer on an annual basis.

**TAPE AND REEL INFORMATION**

**QUADRANT ASSIGNMENTS FOR PIN 1 ORIENTATION IN TAPE**

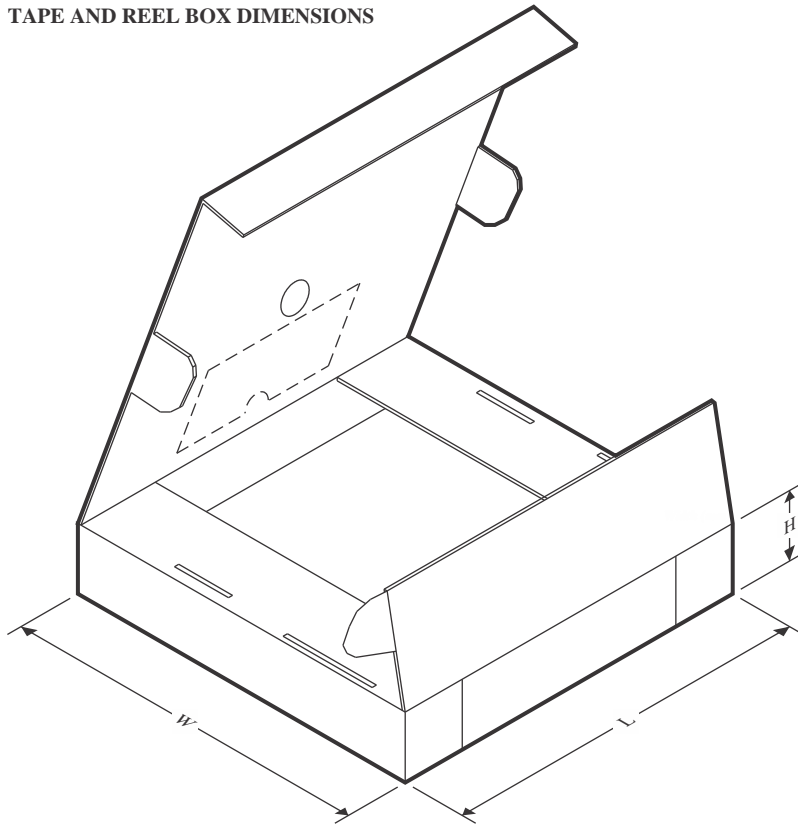

\*All dimensions are nominal

| Device        | Package Type | Package Drawing | Pins | SPQ  | Reel Diameter (mm) | Reel Width W1 (mm) | A0 (mm) | B0 (mm) | K0 (mm) | P1 (mm) | W (mm) | Pin1 Quadrant |
|---------------|--------------|-----------------|------|------|--------------------|--------------------|---------|---------|---------|---------|--------|---------------|
| TRF1108RPVR   | WQFN-HR      | RPV             | 12   | 3000 | 180.0              | 8.4                | 2.3     | 2.3     | 1.15    | 4.0     | 8.0    | Q2            |
| TRF1108RPVRG4 | WQFN-HR      | RPV             | 12   | 3000 | 180.0              | 8.4                | 2.3     | 2.3     | 1.15    | 4.0     | 8.0    | Q2            |

**TAPE AND REEL BOX DIMENSIONS**

\*All dimensions are nominal

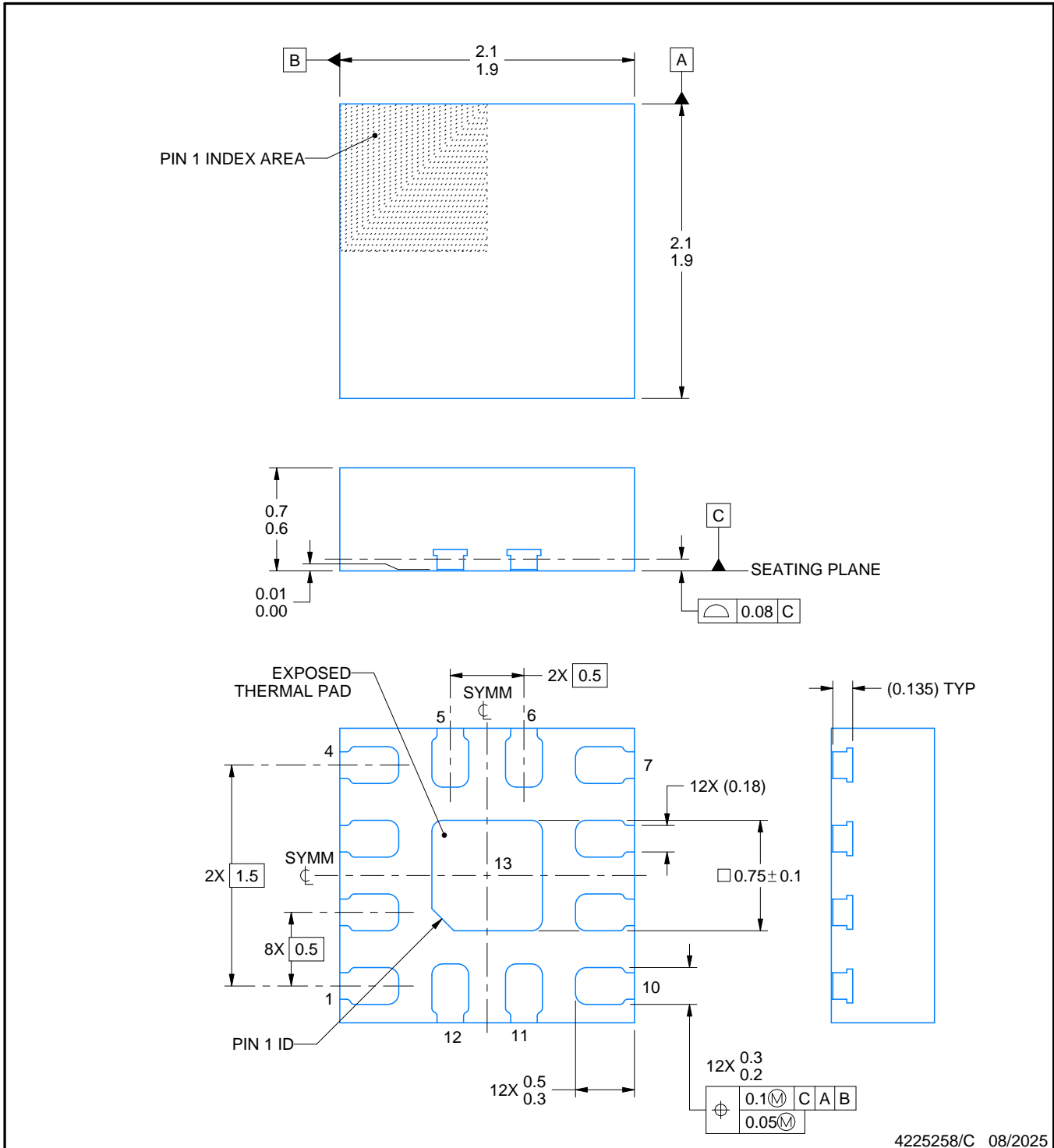
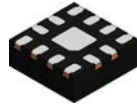
| Device        | Package Type | Package Drawing | Pins | SPQ  | Length (mm) | Width (mm) | Height (mm) |
|---------------|--------------|-----------------|------|------|-------------|------------|-------------|
| TRF1108RPVR   | WQFN-HR      | RPV             | 12   | 3000 | 210.0       | 185.0      | 35.0        |
| TRF1108RPVRG4 | WQFN-HR      | RPV             | 12   | 3000 | 210.0       | 185.0      | 35.0        |



4225258/C 08/2025

NOTES:

1. All linear dimensions are in millimeters. Any dimensions in parenthesis are for reference only. Dimensioning and tolerancing per ASME Y14.5M.
2. This drawing is subject to change without notice.
3. The package thermal pad must be soldered to the printed circuit board for thermal and mechanical performance.

# EXAMPLE BOARD LAYOUT

RPV0012A

WQFN-FCRLF - 0.7 mm max height

PLASTIC QUAD FLATPACK - NO LEAD

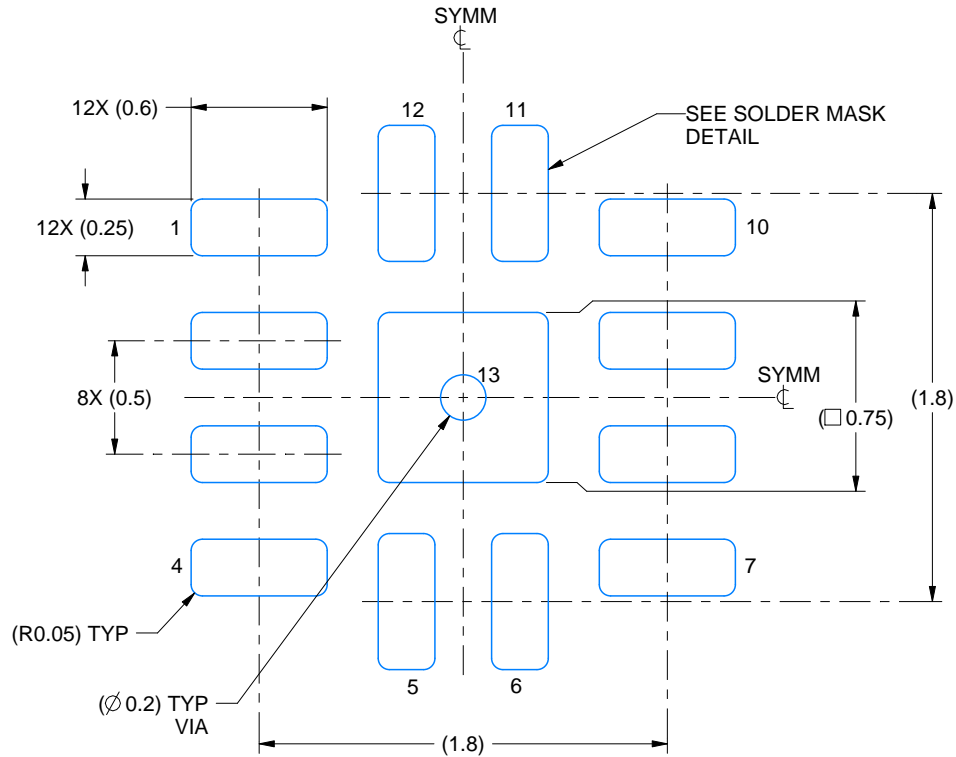

LAND PATTERN EXAMPLE  
EXPOSED METAL SHOWN  
SCALE: 30X

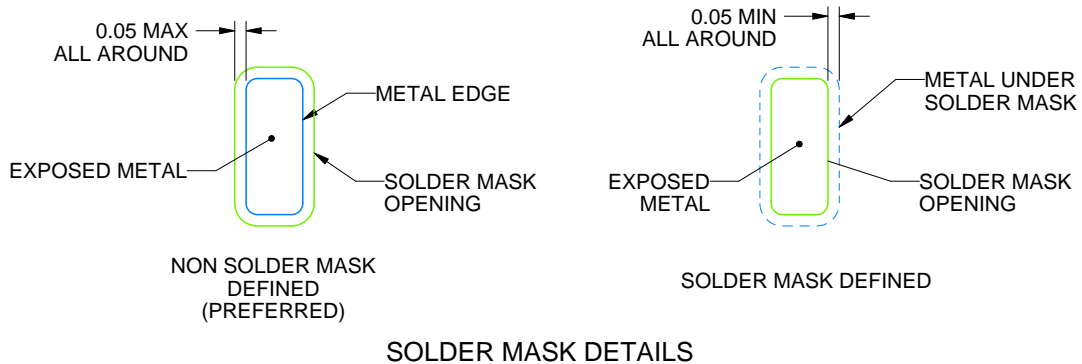

SOLDER MASK DETAILS

4225258/C 08/2025

NOTES: (continued)

- This package is designed to be soldered to a thermal pad on the board. For more information, see Texas Instruments literature number SLUA271 ([www.ti.com/lit/slua271](http://www.ti.com/lit/slua271)).
- Vias are optional depending on application, refer to device data sheet. If any vias are implemented, refer to their locations shown on this view. It is recommended that vias under paste be filled, plugged or tented.

# EXAMPLE STENCIL DESIGN

RPV0012A

WQFN-FCRLF - 0.7 mm max height

PLASTIC QUAD FLATPACK - NO LEAD

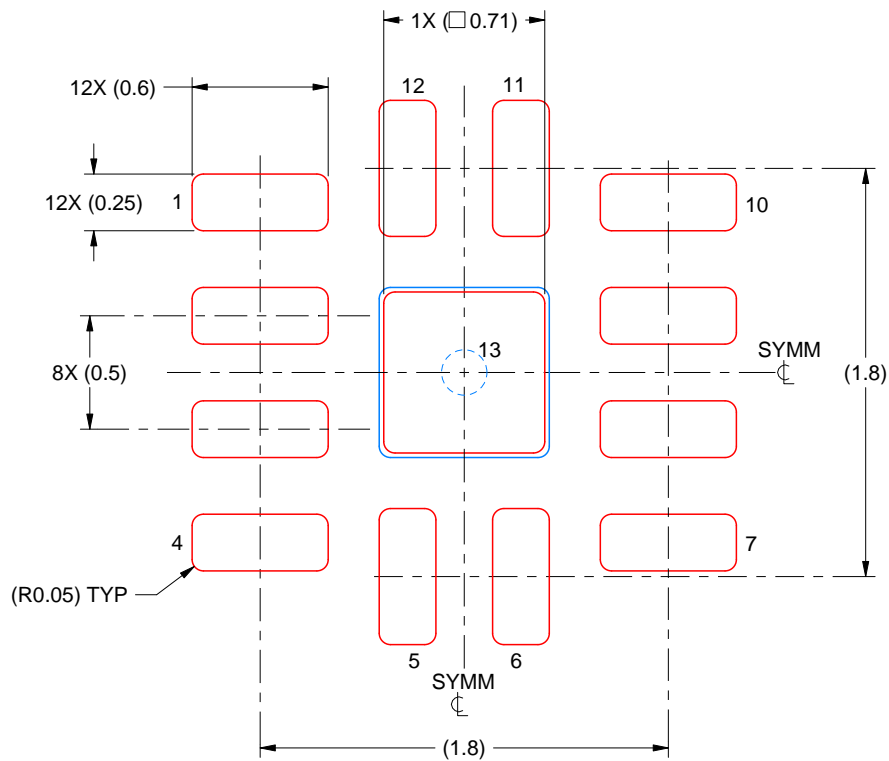

SOLDER PASTE EXAMPLE  
BASED ON 0.125 MM THICK STENCIL  
SCALE: 30X

EXPOSED PAD 13  
90% PRINTED SOLDER COVERAGE BY AREA UNDER PACKAGE

4225258/C 08/2025

NOTES: (continued)

6. Laser cutting apertures with trapezoidal walls and rounded corners may offer better paste release. IPC-7525 may have alternate design recommendations.

## IMPORTANT NOTICE AND DISCLAIMER

TI PROVIDES TECHNICAL AND RELIABILITY DATA (INCLUDING DATASHEETS), DESIGN RESOURCES (INCLUDING REFERENCE DESIGNS), APPLICATION OR OTHER DESIGN ADVICE, WEB TOOLS, SAFETY INFORMATION, AND OTHER RESOURCES "AS IS" AND WITH ALL FAULTS, AND DISCLAIMS ALL WARRANTIES, EXPRESS AND IMPLIED, INCLUDING WITHOUT LIMITATION ANY IMPLIED WARRANTIES OF MERCHANTABILITY, FITNESS FOR A PARTICULAR PURPOSE OR NON-INFRINGEMENT OF THIRD PARTY INTELLECTUAL PROPERTY RIGHTS.

These resources are intended for skilled developers designing with TI products. You are solely responsible for (1) selecting the appropriate TI products for your application, (2) designing, validating and testing your application, and (3) ensuring your application meets applicable standards, and any other safety, security, regulatory or other requirements.

These resources are subject to change without notice. TI grants you permission to use these resources only for development of an application that uses the TI products described in the resource. Other reproduction and display of these resources is prohibited. No license is granted to any other TI intellectual property right or to any third party intellectual property right. TI disclaims responsibility for, and you fully indemnify TI and its representatives against any claims, damages, costs, losses, and liabilities arising out of your use of these resources.

TI's products are provided subject to [TI's Terms of Sale](#), [TI's General Quality Guidelines](#), or other applicable terms available either on [ti.com](http://ti.com) or provided in conjunction with such TI products. TI's provision of these resources does not expand or otherwise alter TI's applicable warranties or warranty disclaimers for TI products. Unless TI explicitly designates a product as custom or customer-specified, TI products are standard, catalog, general purpose devices.

TI objects to and rejects any additional or different terms you may propose.

Copyright © 2025, Texas Instruments Incorporated

Last updated 10/2025

## Looking for pricing, stock, or lifecycle information?

Click below to explore more details on WIN SOURCE:

 [View TRF1108RPVR on WIN SOURCE](#)

 [Texas Instruments](#) Information

## Optimize Your Supply Chain with WIN SOURCE Solutions

-  Global Sourcing Solution
-  Obsolete Management
-  Cost Control Management
-  Shortage Management
-  Alternative Solution
-  Excess Inventory Management