

### Product Overview

The RFCM3327 is a Power Doubler amplifier SMD Module. The part employs GaAs pHEMT die and GaN HEMT die, has high output capability, and is operated from 45 MHz to 1218 MHz. It provides excellent linearity and superior return loss performance with low noise and optimal reliability. DC current of the device can be externally adjusted for optimum distortion performance versus power consumption over a wide range of output level.



9 pin, 9.0 mm x 8.0 mm x 1.375 mm

### Functional Block Diagram

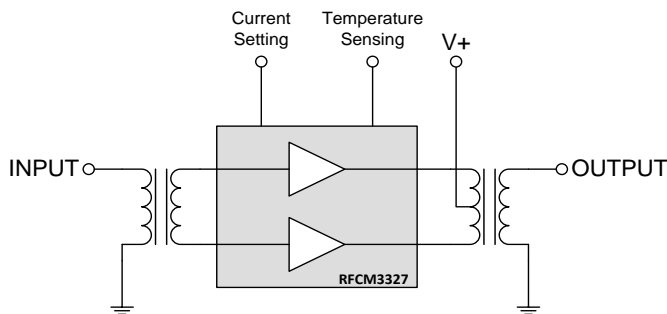

### Key Features

- Excellent Linearity
- Superior Return Loss Performance
- Extremely Low Distortion
- Optimal Reliability
- Low Noise
- Unconditionally Stable Under all Terminations
- Extremely High Output Capability
- 22.5 dB Min. Gain at 1218 MHz
- 480 mA Max. at 24 VDC
- Temperature Sensing Feature

### Applications

- 45 MHz to 1218 MHz CATV Amplifier Systems

### Ordering Information

Part No.	Description
RFCM3327SB	Sample bag with 5 pieces
RFCM3327SR	7" Reel with 100 pieces
RFCM3327TR13	13" Reel with 1000 pieces
RFCM3327PCBA-410	Fully Assembled Evaluation Board

## Absolute Maximum Ratings

Parameter	Rating
RF Input Voltage (single tone; on evaluation board)	75 dBmV
DC Supply Over-Voltage (5 minutes)	30 V
Storage Temperature	-40 to +100 °C
Operating Mounting Base Temperature	-30 to +110 °C

Exceeding any one or a combination of the Absolute Maximum Rating conditions may cause permanent damage to the device. Extended application of Absolute Maximum Rating conditions to the device may reduce device reliability.

## Electrical Specifications

Parameter	Conditions <sup>(1)</sup>	Min	Typ	Max	Units
Operational Frequency Range		45		1218	MHz
Power Gain	45 MHz	21.5	22.0	22.5	dB
	1218 MHz	22.5	23.0	24.0	dB
Slope <sup>(2)</sup>	45 MHz to 1218 MHz	0.5	1.5	2.0	dB
Flatness of Frequency Response	45 MHz to 1218 MHz (Peak to Valley)			1.5	dB
Input Return Loss	45 MHz to 320 MHz	-20			dB
	320 MHz to 640 MHz	-19			dB
	640 MHz to 870 MHz	-18			dB
	870 MHz to 1000 MHz	-16			dB
	1000 MHz to 1218 MHz	-15			dB
Output Return Loss	45 MHz to 320 MHz	-18			dB
	320 MHz to 640 MHz	-17			dB
	640 MHz to 1218 MHz	-16			dB
Noise Figure	50 MHz to 1218 MHz		2.5	3.5	dB
Total Current Consumption (DC)			470	480	mA
Thermal Resistance	Junction to Mounting Base		3.7		K/W
CTB	V <sub>O</sub> = 61 dBmV at 1218 MHz, 22 dB extrapolated tilt, 79 analog channels plus 111 digital channels (-6 dB offset) <sup>(3)(5)</sup>		-80	-74	dBc
XMOD			-76	-72	dBc
CSO			-80	-74	dBc
CIN		55	58		dB
CTB	V <sub>O</sub> = 62 dBmV at 1000 MHz, 18 dB extrapolated tilt, 79 analog channels plus 75 digital channels (-6 dB offset) <sup>(4)(5)</sup>		-73		dBc
XMOD			-68		dBc
CSO			-68		dBc
CIN			55		dB

### Notes:

- Test conditions unless otherwise noted: V<sub>+</sub>=24 V, T<sub>MB</sub>=30 °C, Z<sub>S</sub>=Z<sub>L</sub>=75 Ω, I<sub>DC</sub>=I<sub>DC</sub> typical.
- The slope is defined as the difference between the gain at the start frequency and the gain at the stop frequency.
- 79 analog channels, NTSC frequency raster: 55.25 MHz to 547.25 MHz, +39 dBmV to +48.3 dBmV tilted output level, plus 111 digital channels, -6 dB offset relative to the equivalent analog carrier.
- 79 analog channels, NTSC frequency raster: 55.25 MHz to 547.25 MHz, +44 dBmV to +53.4 dBmV tilted output level, plus 75 digital channels, -6 dB offset relative to the equivalent analog carrier.
- Composite Second Order (CSO) - The CSO parameter (both sum and difference products) is defined by ANSI/SCTE 6. Composite Triple Beat (CTB) - The CTB parameter is defined by ANSI/SCTE 6. Cross Modulation (XMOD) - Cross modulation (XMOD) is measured at baseband (selective voltmeter method), referenced to 100% modulation of the carrier being tested. Carrier to Intermodulation Noise (CIN) - The CIN parameter is defined by ANSI/SCTE 17 (Test procedure for carrier to noise).

## RFCM3327 Current Adjustment

The RFCM3327 can be operated over a wide range of current to provide maximum required performance with minimum current consumption. Changing the value of resistor R3 on application circuit allows a variation of the current between 470 mA and 350 mA (typ.). Within the recommended range of current between 470 mA and 370 mA gain (S21) change is less than 0.2 dB (typ.) and noise figure change is less than 0.2 dB (typ.).

## Device Current versus Resistor R3 (typical values)

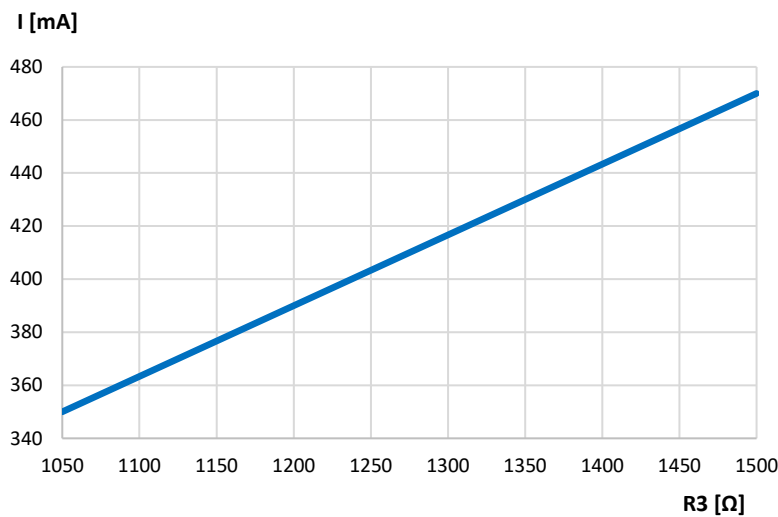

Device Current [mA], typical	R3 [Ω]
470	1500
430	1350
390	1200
350	1050

Test conditions:  $V_+ = 24\text{ V}$ ,  $T_{MB} = 30\text{ °C}$ ,  $Z_S = Z_L = 75\text{ Ω}$

## Device Current versus Distortion Degradation (typical values)

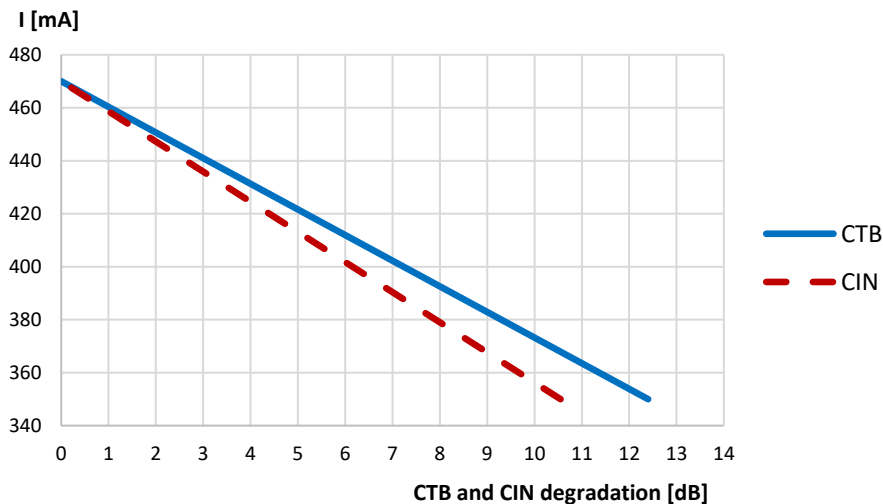

Test condition:  $V_+ = 24\text{ V}$ ,  $T_{MB} = 30\text{ °C}$ ,  $Z_S = Z_L = 75\text{ Ω}$ ;  $V_O = 61\text{ dBmV}$  at 1218 MHz, 22 dB extrapolated tilt, 79 analog channels plus 111 digital channels (-6 dB offset)

## RFCM3327 Temperature Sensing Feature

The RFCM3327 provides an internal NTC resistor for temperature sensing. This resistor is located right next to the output transistor stage. Within the application circuit the NTC is part of a voltage divider. The output voltage of the voltage divider ( $V_t$ ) can be correlated to the module backside temperature.

## Module Backside Temperature versus $V_t$ (typical values)

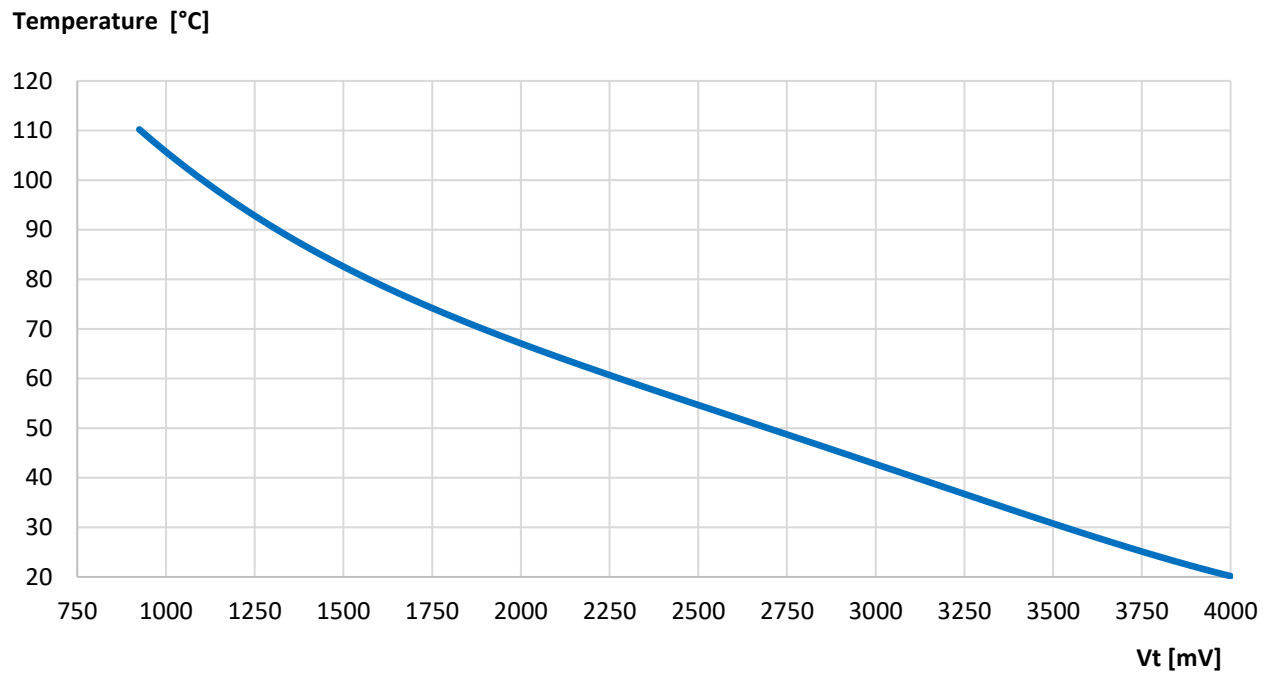

**Evaluation Board Schematic**

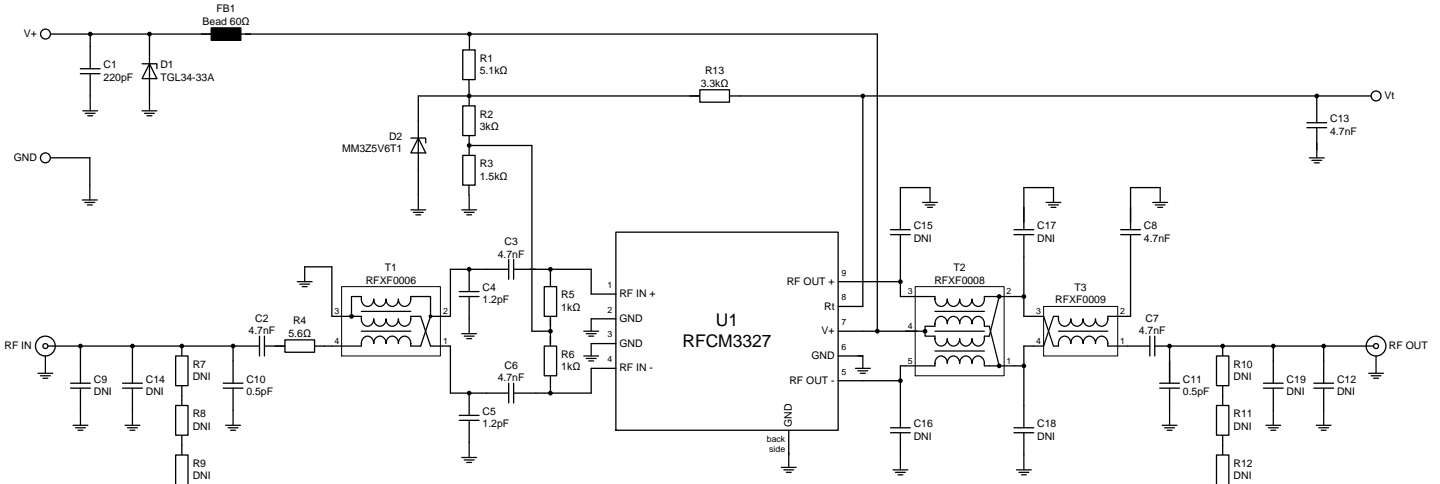

**Evaluation Board Assembly Drawing**

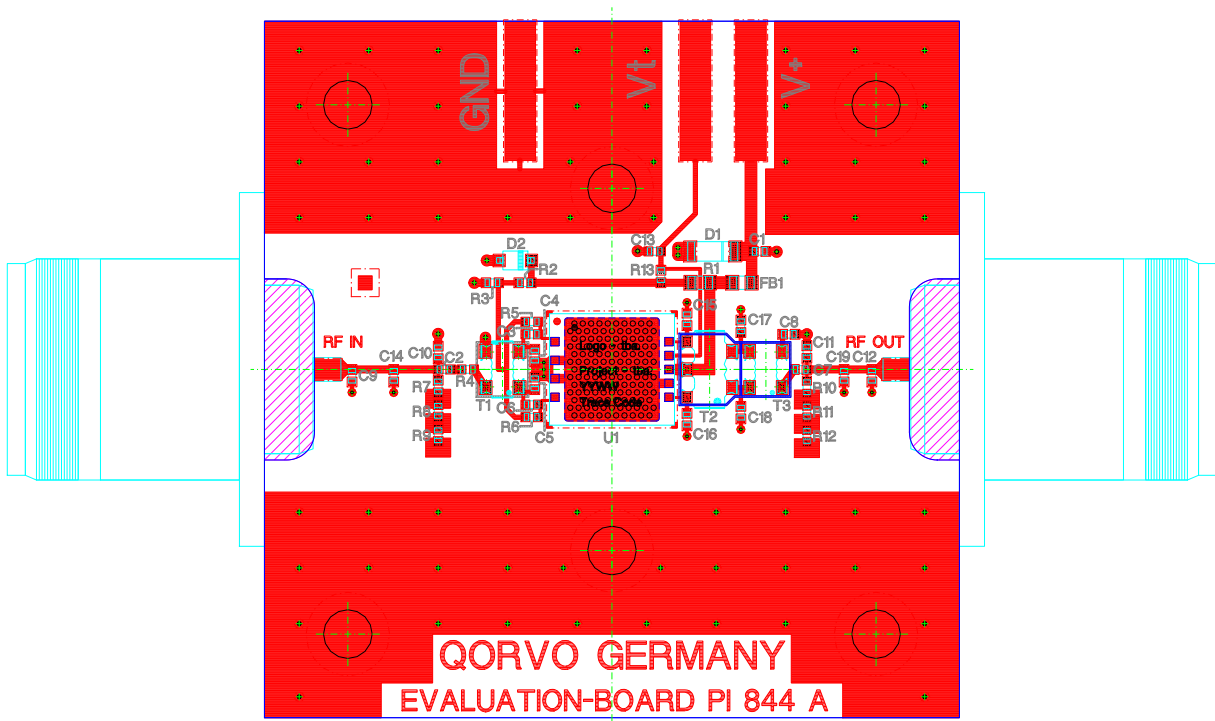

Note: Vias are required under the backside paddle of this device for proper RF/DC grounding and thermal dissipation. A via drill diameter of 0.4mm and a minimum via wall copper plating thickness of 25um is recommended. Open vias are preferred to allow flux and gases to escape during reflow soldering and therefore to minimize voiding. Underneath this via array a heat sink with thermal grease needs to be placed which is able to dissipate the complete module DC power (up to 11.3 Watts). In any case the module backside temperature should not exceed 110 °C.

## Evaluation Board Bill of Materials (BOM)

Reference Des.	Value	Description	Manuf.	Part Number
n/a	n/a	Printed Circuit Board	Qorvo	PI844A
C1	220 pF	Cap., 0402, 50V, NP0/C0G	various	
C2, C3, C6, C7, C8, C13	4.7 nF	Cap., 0402, ±10%, 50V, X7R	various	
C4, C5	1.2 pF	Cap., 0402, ±0.25pF, 50V, NP0/C0G	various	
C9, C12, C14, C15, C16, C17, C18, C19	DNI	Cap., 0402, NP0/C0G <sup>(1)</sup>	various	
C10, C11	0.5 pF	Cap., 0402, ±0.1pF, 50V, NP0/C0G <sup>(1)</sup>	various	
R1	5.1 kΩ	Res., 0603, ±1%, TK100	various	
R2	3 kΩ	Res., 0402, ±1%, TK100	various	
R3	1.5 kΩ	Res., 0402, ±1%, TK100	various	
R4	5.6 Ω	Res., 0402, ±1%, TK200	various	
R5, R6	1 kΩ	Res., 0402, ±1%, TK100	various	
R7, R8, R9, R10, R11, R12	DNI	Res., 0402, 0Ω <sup>(1)</sup>	various	
R13	3.3 kΩ	Res., 0402, ±1%, TK100	various	
FB1	60 Ω @ 100 MHz	Impedance Bead	Taiyo Yuden	BK 1608HS600-T
D1	TGL34-33A	Transient Voltage Suppressor Diode	Diotec	TGL34-33A
D2	5.6 V	Zener Diode	ON Semiconductor	MM3Z5V6T1G
T1	RFXF0006	Transformer	Qorvo	RFXF0006
T2	RFXF0008	Transformer	Qorvo	RFXF0008
T3	RFXF0009	Transformer	Qorvo	RFXF0009
U1	RFCM3327	DUT	Qorvo	RFCM3327

Note: 1. Optional to improve matching in application.

## Pin Out

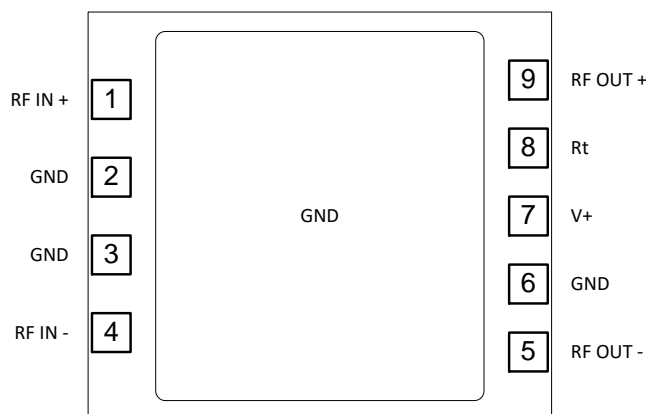

Top View

### Package Outline and Branding Drawing

(Dimensions in millimeters)

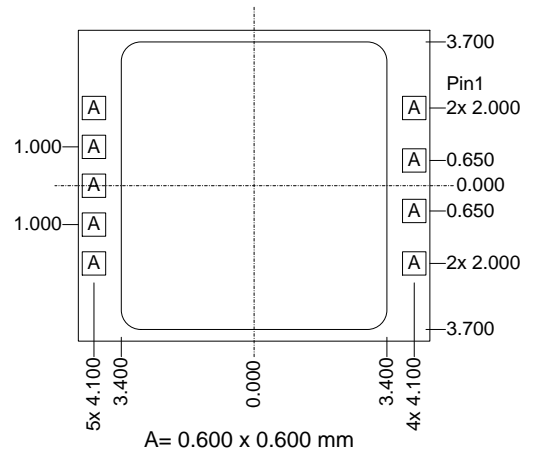
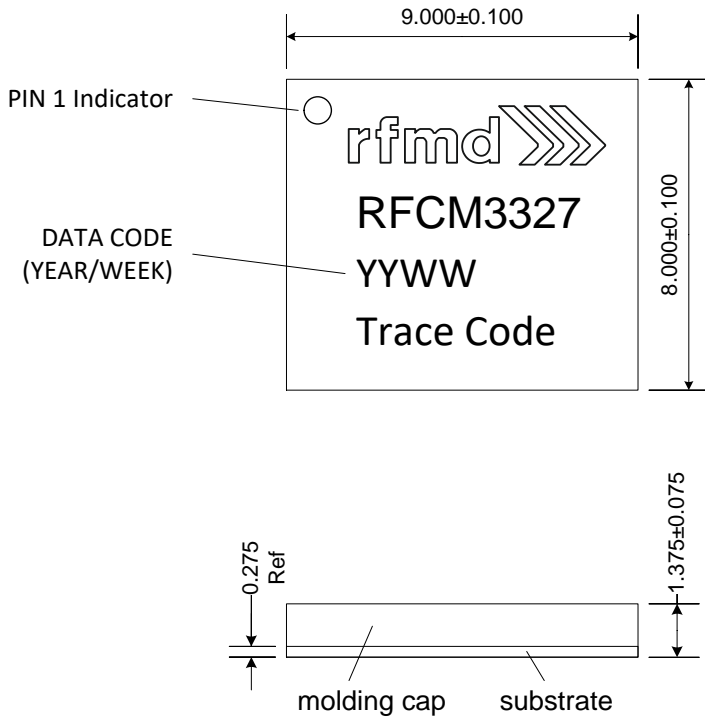

### Pin Names and Descriptions

Pin	Name	Description
1	RF IN +	RF AMP Positive Input
2, 3, 6	GND	Ground pins
4	RF IN -	RF AMP Negative Input
5	RF OUT -	RF AMP Negative Output
7	V+	Supply Voltage, +24V
8	Rt	NTC Output for Temperature Sensing
9	RF OUT +	RF AMP Positive Output

## Handling Precautions

Parameter	Rating	Standard
ESD – Human Body Model (HBM)	Class 1A	ESDA / JEDEC JS-001-2012
ESD – Charged Device Model (CDM)	Class C1	JEDEC JESD22-C101F
MSL – Moisture Sensitivity Level	Level 3	IPC/JEDEC J-STD-020



Caution!  
ESD-Sensitive Device

## Solderability

Compatible with both lead-free (260°C max. reflow temp.) and tin/lead (245°C max. reflow temp.) soldering processes. Solder profiles available upon request.

Contact plating: ENEPIG

## RoHS Compliance

This part is compliant with 2011/65/EU RoHS directive (Restrictions on the Use of Certain Hazardous Substances in Electrical and Electronic Equipment) as amended by Directive 2015/863/EU.

This product also has the following attributes:

- Halogen Free (Chlorine, Bromine)
- Antimony Free
- TBBP-A (C15H12Br4O2) Free
- PFOS Free
- SVHC Free

## Contact Information

For the latest specifications, additional product information, worldwide sales and distribution locations:

**Web:** [www.qorvo.com](http://www.qorvo.com)

**Tel:** 1-844-890-8163

**Email:** [customer.support@qorvo.com](mailto:customer.support@qorvo.com)

## Important Notice



The information contained herein is believed to be reliable; however, Qorvo makes no warranties regarding the information contained herein and assumes no responsibility or liability whatsoever for the use of the information contained herein. All information contained herein is subject to change without notice. Customers should obtain and verify the latest relevant information before placing orders for Qorvo products. The information contained herein or any use of such information does not grant, explicitly or implicitly, to any party any patent rights, licenses, or any other intellectual property rights, whether with regard to such information itself or anything described by such information. **THIS INFORMATION DOES NOT CONSTITUTE A WARRANTY WITH RESPECT TO THE PRODUCTS DESCRIBED HEREIN, AND QORVO HEREBY DISCLAIMS ANY AND ALL WARRANTIES WITH RESPECT TO SUCH PRODUCTS WHETHER EXPRESS OR IMPLIED BY LAW, COURSE OF DEALING, COURSE OF PERFORMANCE, USAGE OF TRADE OR OTHERWISE, INCLUDING THE IMPLIED WARRANTIES OF MERCHANTABILITY AND FITNESS FOR A PARTICULAR PURPOSE.**

Without limiting the generality of the foregoing, Qorvo products are not warranted or authorized for use as critical components in medical, life-saving, or life-sustaining applications, or other applications where a failure would reasonably be expected to cause severe personal injury or death.

Copyright 2016 © Qorvo, Inc. | Qorvo is a registered trademark of Qorvo, Inc.

## Looking for pricing, stock, or lifecycle information?

Click below to explore more details on WIN SOURCE:

-  [View RFCM3327TR13 on WIN SOURCE](#)
-  [Qorvo US Inc. Information](#)

## Optimize Your Supply Chain with WIN SOURCE Solutions

-  Global Sourcing Solution
-  Obsolete Management
-  Cost Control Management
-  Shortage Management
-  Alternative Solution
-  Excess Inventory Management