

General Description

The QPL3050 is a broadband MMIC driver amplifier housed in a leadless 3x3 mm plastic surface mount package. The device operates from 6.0 to 14.0GHz and delivers 20 dBm saturated output power with 19 dB of small signal gain and 24% power-added efficiency from a single 5 V supply.

The QPL3050 is ideally suited for EW and communications systems where small size, and low power consumption are needed.

The QPL3050 is internally matched to 50 ohms and includes integrated DC blocking caps on both RF ports allowing for simple system integration.

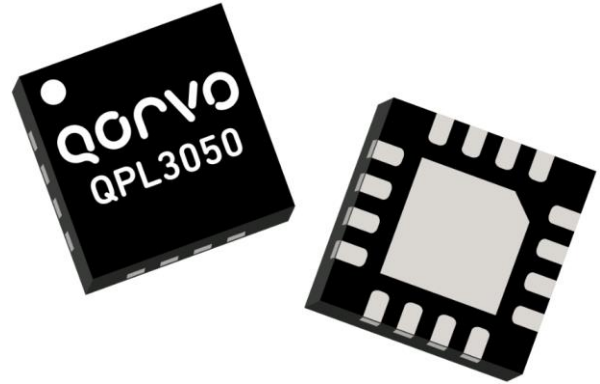

Product Features

- Frequency Range: 6 – 14 GHz
- Small Signal Gain: 19 dB
- P1dB: 18.5 dBm
- Saturated Power: 20 dBm
- PAE @ Psat: 24%
- Avg IMD3: -45 dBc @ Pout = 5 dBm/tone, tone space=10 MHz
- Noise Figure: 4.0 dB
- Bias: $V_{DD} = 5\text{ V}$, $I_{DQ} = 74\text{ mA}$
- Plastic Overmold Package
- Package Dimensions: 3.0 x 3.0 x 0.85 mm

*Performance is typical across frequency.
Please reference electrical specification table and data plots for more details.*

Applications

- Satellite Communications
- Point to Point Communications
- Military and Commercial Radar Applications

Functional Block Diagram

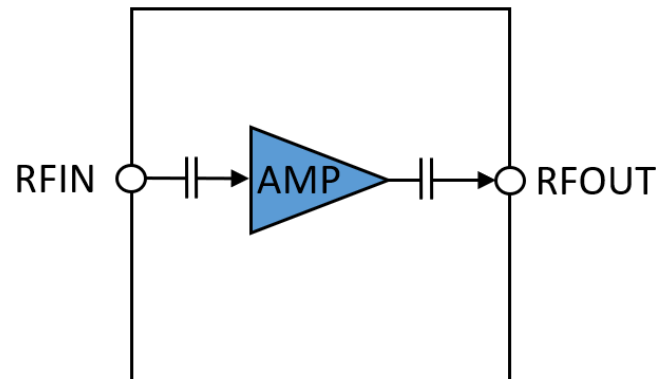

Ordering Information

Part No.	Description
QPL3050SR	Tape and Reel, 7", Qty 100
QPL3050TR7	Tape and Reel, 7", Qty 750
QPL3050EVB	QPL3050 Evaluation Board, Qty 1

Absolute Maximum Ratings

Parameter	Min Value	Max Value	Units
Drain Voltage (V _{DD})	-	6.0	V
Drain Current	-	100	mA
RF Input Power (50 Ω, 85 °C)	-	15	dBm
Channel Temperature, T _{CH}	-	175	°C
Mounting Temperature (30 seconds)	-	260	°C
Storage Temperature	-55	150	°C

Operation of this device outside the parameter ranges given above may cause permanent damage. These are stress ratings only, and functional operation of the device at these conditions is not implied. Extended application of Absolute Maximum Rating conditions may reduce device reliability.

Recommended Operating Conditions

Parameter	Min	Typical	Max	Units
Drain Voltage (V _{DD})	3	5	5.5	V
Quiescent Drain Current (I _{DQ} , typical, self-biased)		74		mA
Operating Temperature Range	-40		85	°C

Electrical specifications are measured at specified test conditions. Specifications are not guaranteed over all recommended operating conditions.

Electrical Specifications

Parameter	Freq points	Min	Typical	Max	Units
Frequency		6		14	GHz
Small Signal Gain	6GHz	17.5	18.5		dB
	10GHz	17	19.5		
	14GHz	16	17.4		
Noise Figure			4		dB
Saturated Power (P _{in} = 9 dBm)	6GHz	17	20.8		dBm
	10GHz	16	20.2		
	14GHz	15	19.6		
1-dB Compression Point	6GHz	14	19.0		dBm
	10GHz	13	18.5		
	14GHz	13	18.5		
PAE @ P _{sat}			24		%
Input Return Loss			12		dB
Output Return Loss			13		dB
3 RD Order Intermodulation level (P _{out} =5 dBm/tone, tone space=10 MHz)			-45		dBc
Output TOI (P _{out} =0 dBm/ tone)			25		dBm
Gain Temperature Coefficient			-0.014		dB/°C

Test Conditions unless otherwise stated: V_{DD} = 5 V, I_{DQ} = 74 mA, 25 °C. Data de-embedded of fixture losses

Performance Plots – Small Signal

Test Conditions unless otherwise stated: $V_{DD} = 5\text{ V}$, $I_{DQ} = 74\text{ mA}$, $P_{in} = -30\text{ dBm}$, $T_{base} = 25\text{ }^{\circ}\text{C}$

Gain vs Temperature

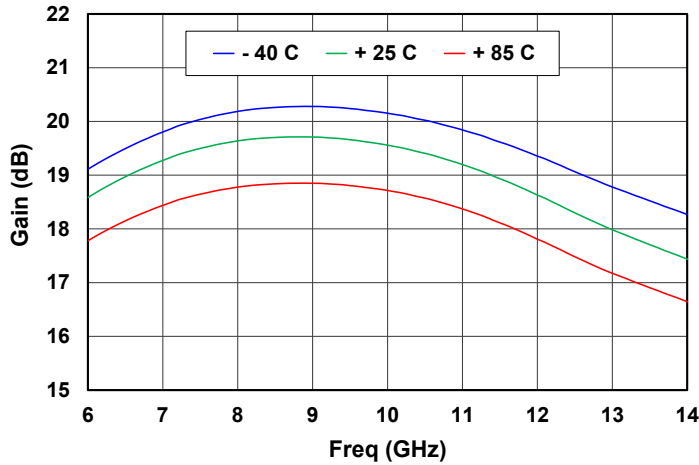

Gain vs Voltage

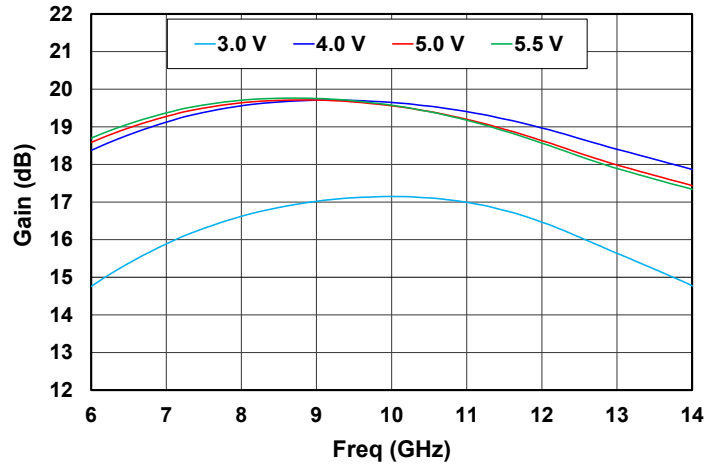

Input Return Loss vs Temperature

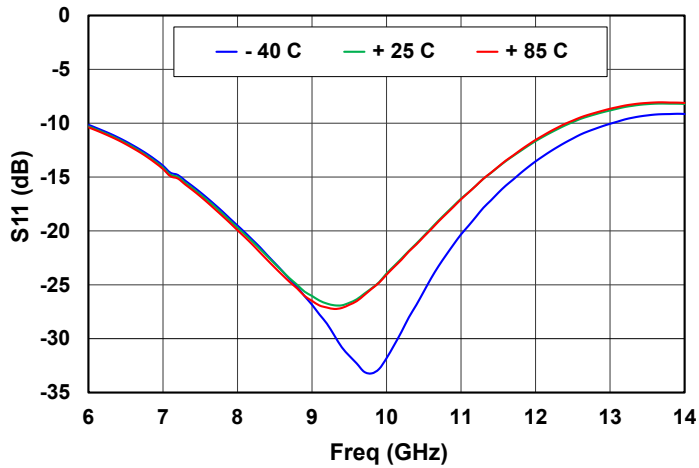

Input Return Loss vs Voltage

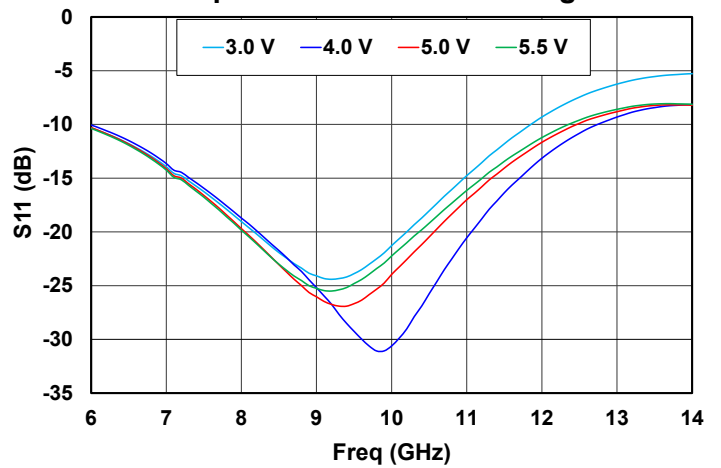

Output Return Loss vs Temperature

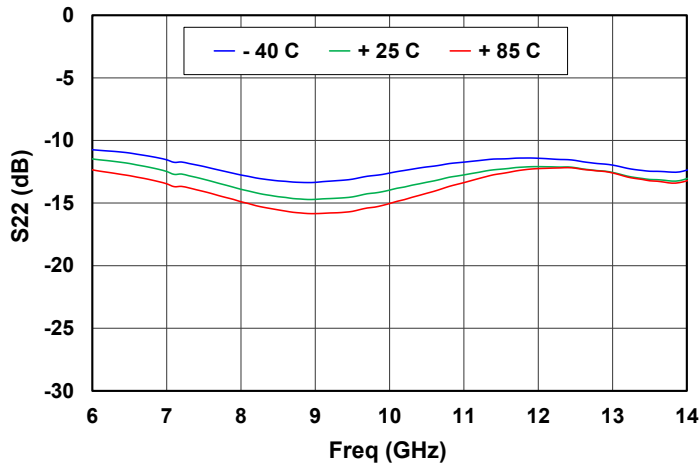

Output Return Loss vs Voltage

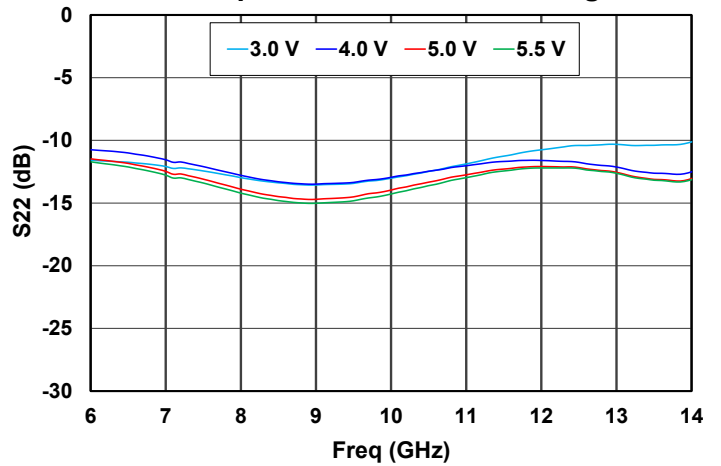

Performance Plots – Noise Figure

Test Conditions unless otherwise stated: $V_{DD} = 5V$, $I_{DQ} = 74\text{ mA}$, $P_{in} = -30\text{ dBm}$, $T_{base} = 25\text{ }^{\circ}\text{C}$

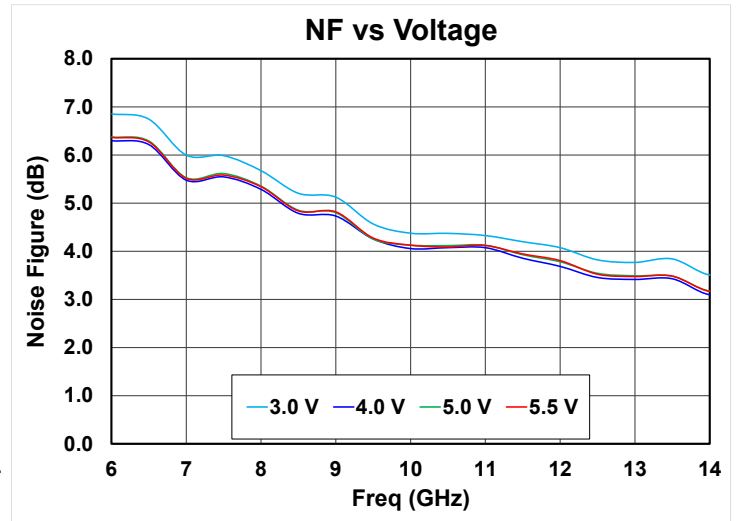
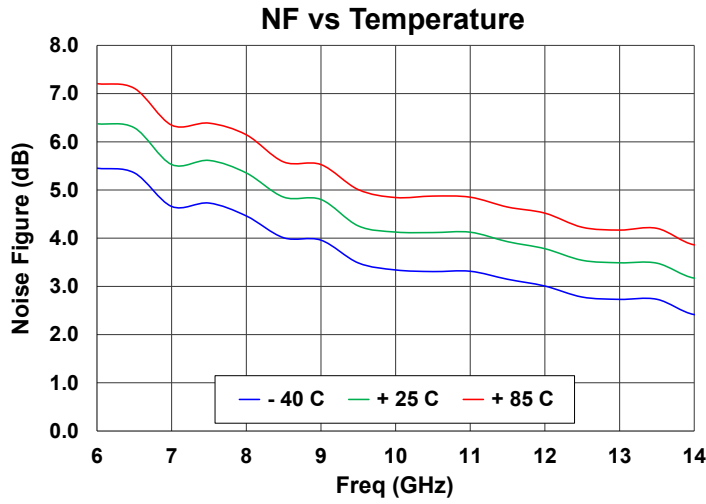

Performance Plots – Power

Test Conditions unless otherwise stated: $V_{DD} = 5V$, $I_{DQ} = 74\text{ mA}$, CW mode, $T_{base} = 25\text{ }^{\circ}\text{C}$

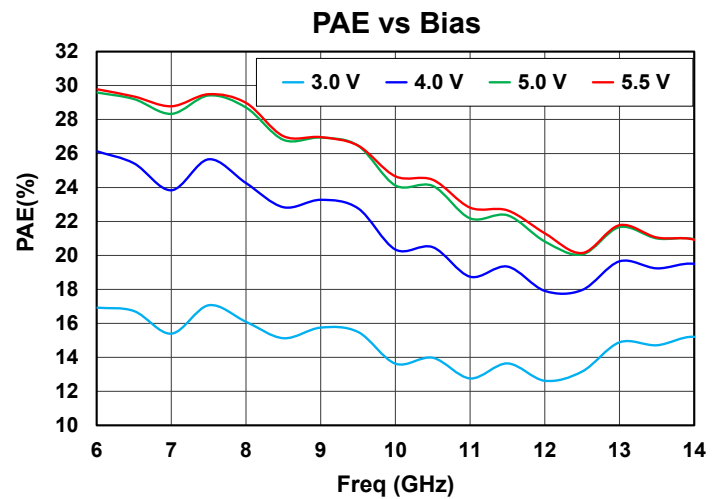
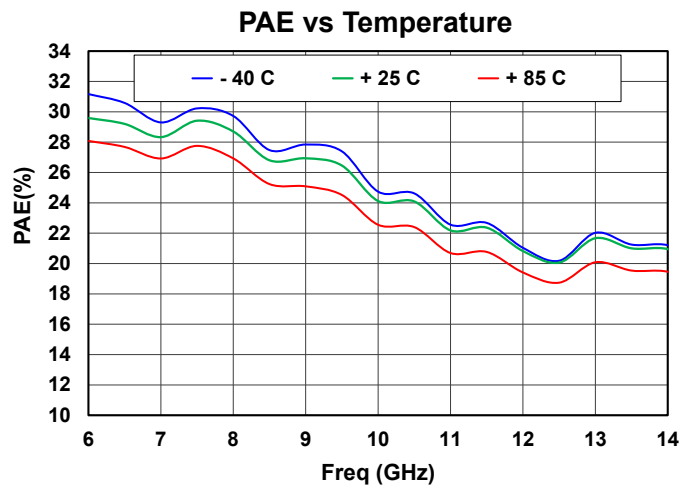
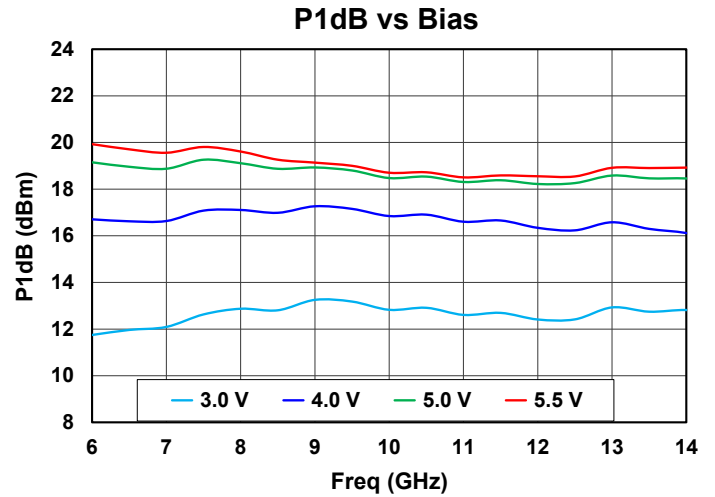
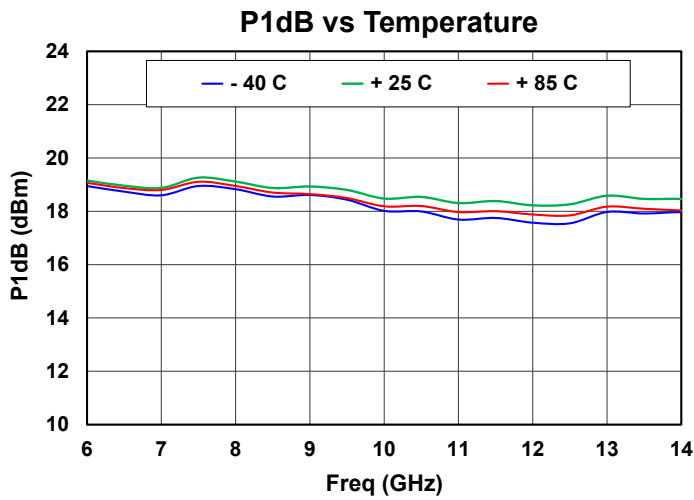
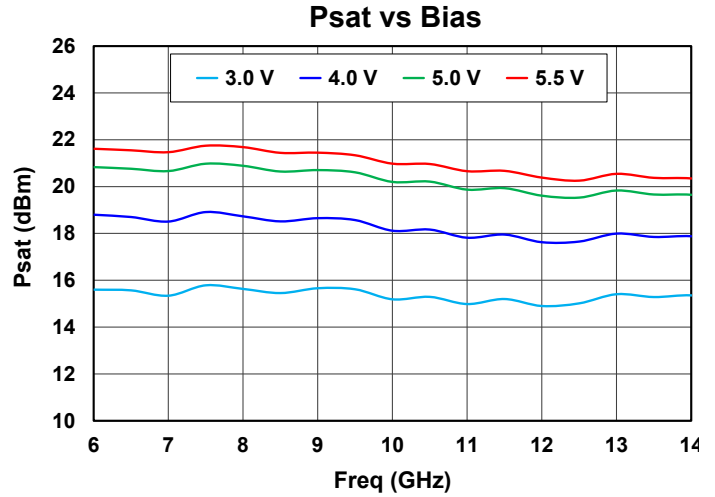
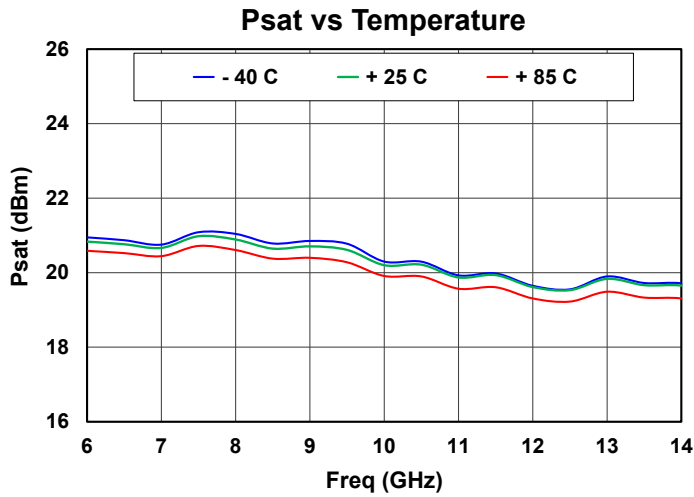

Performance Plots – Power

Test Conditions unless otherwise stated: $V_{DD} = 5V$, $I_{DQ} = 74\text{ mA}$, CW mode, $T_{base} = 25\text{ }^{\circ}\text{C}$

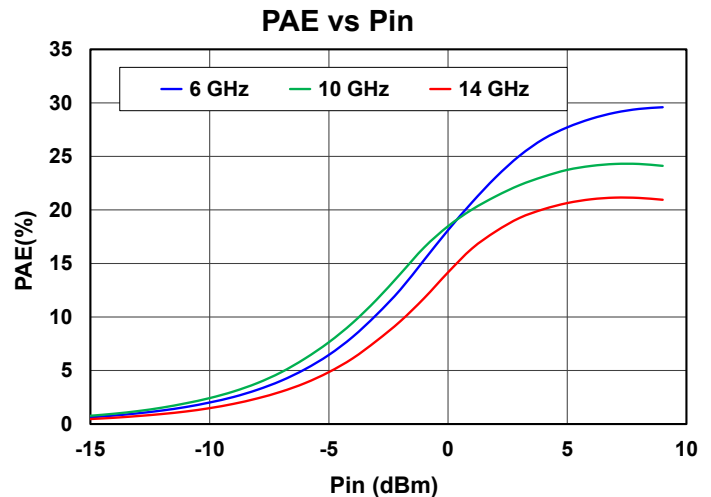
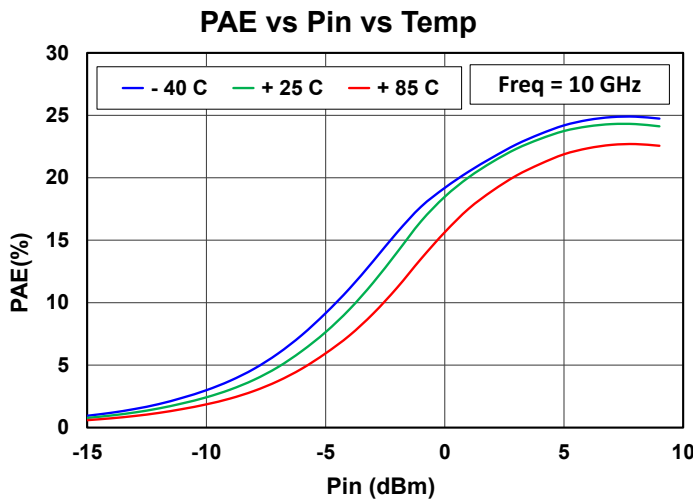
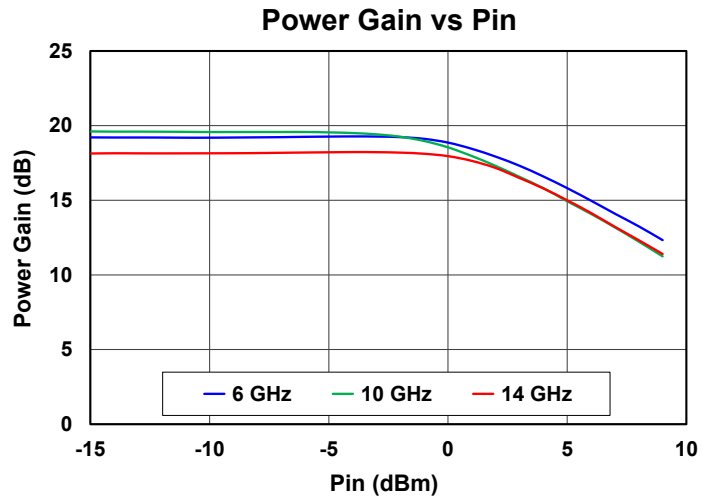
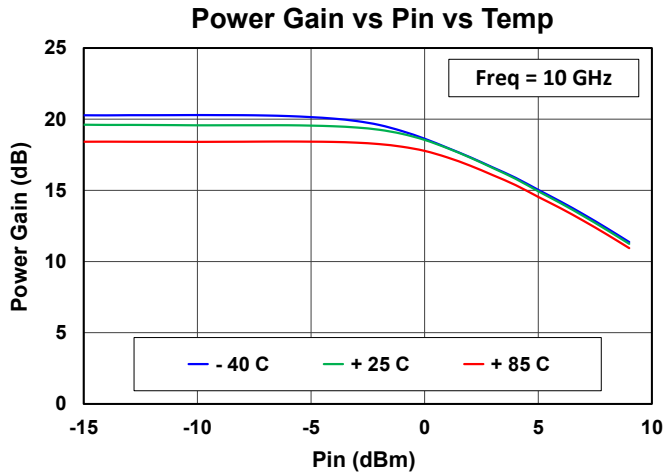
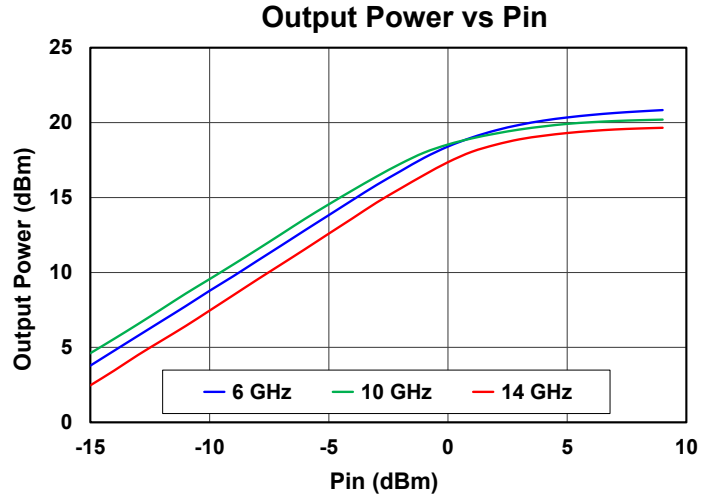
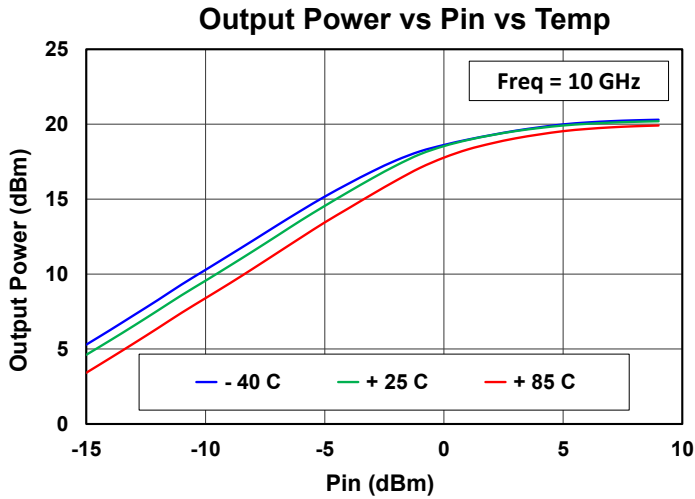

Performance Plots – Power

Test Conditions unless otherwise stated: $V_{DD} = 5V$, $I_{DQ} = 74\text{ mA}$, CW mode, $T_{base} = 25\text{ }^{\circ}\text{C}$

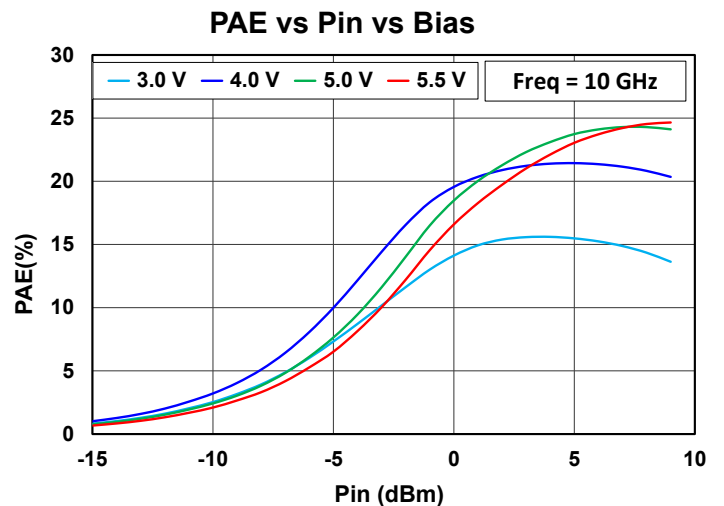
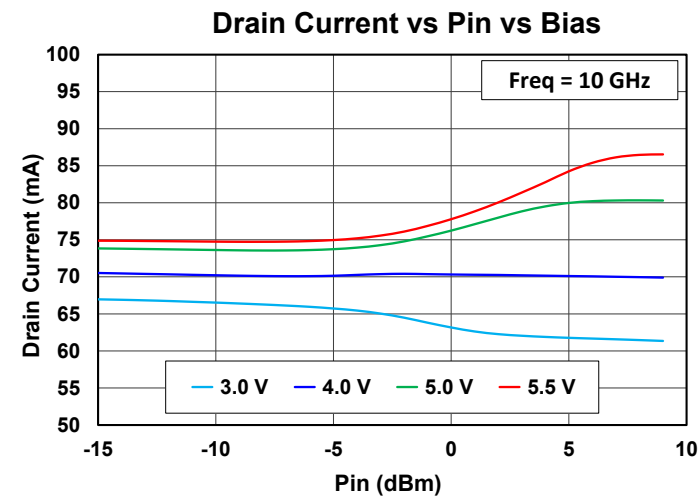
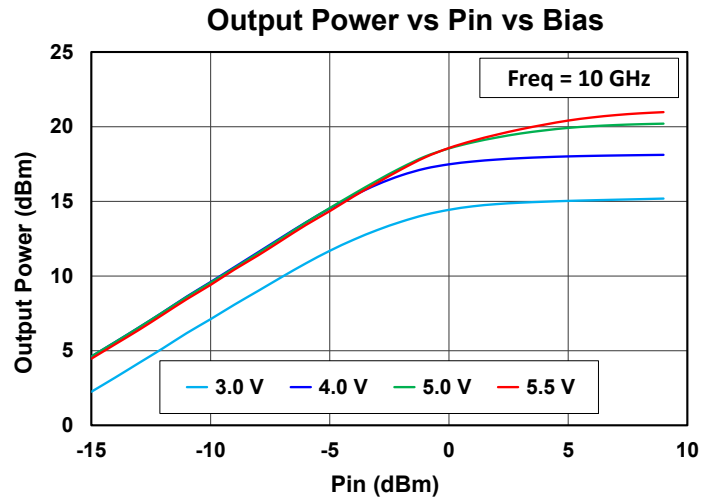
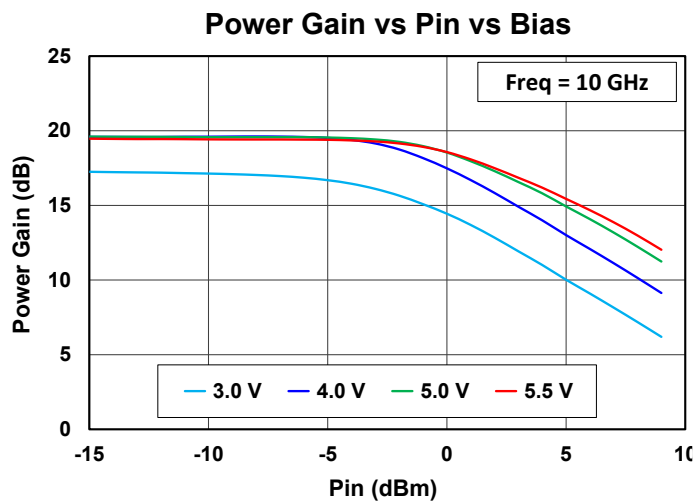
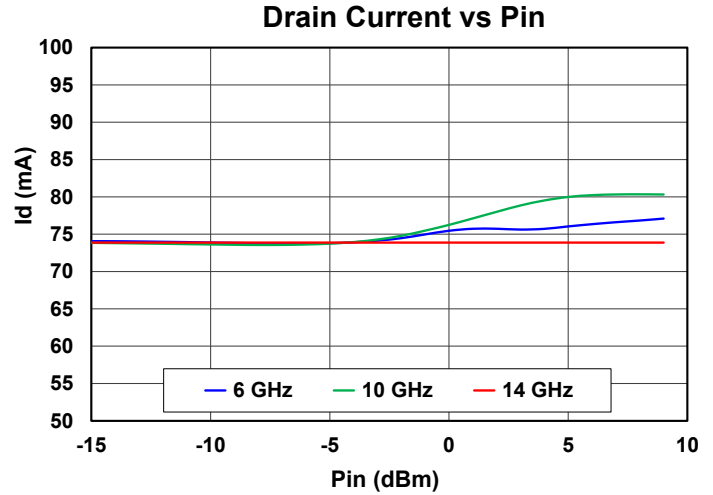
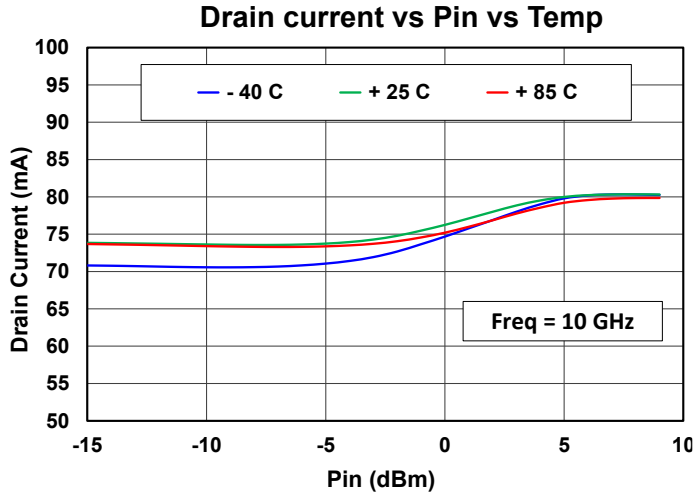

Performance Plots – Linearity

Test Conditions unless otherwise stated: $V_{DD} = 5V$, $I_{DQ} = 74\text{ mA}$, Tone spacing = 10 MHz, $T_{base} = 25\text{ }^{\circ}\text{C}$

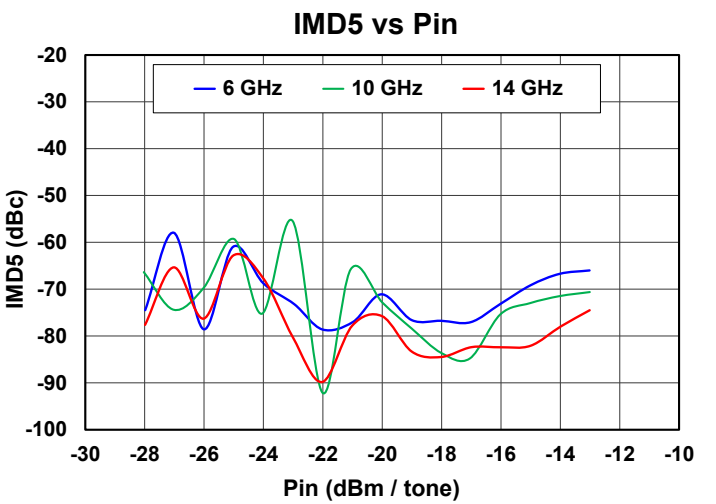
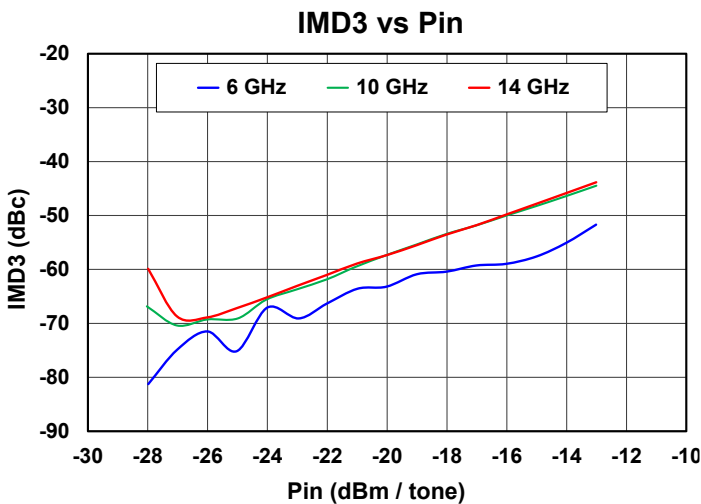
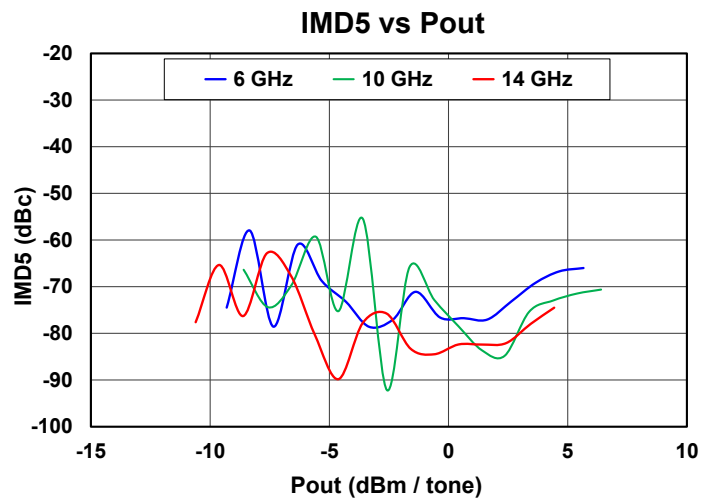
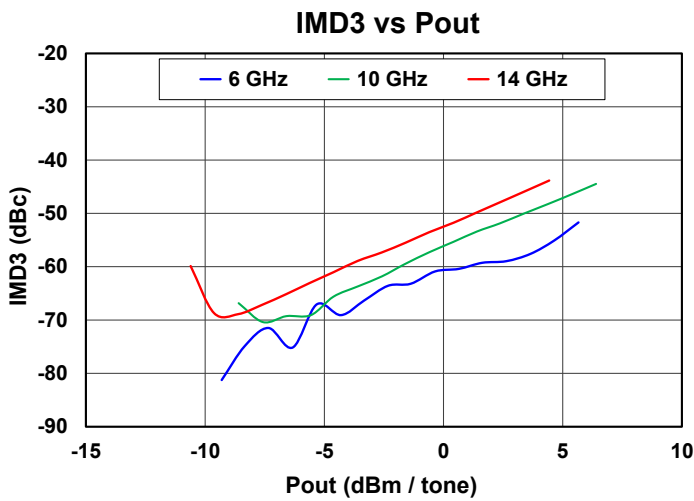
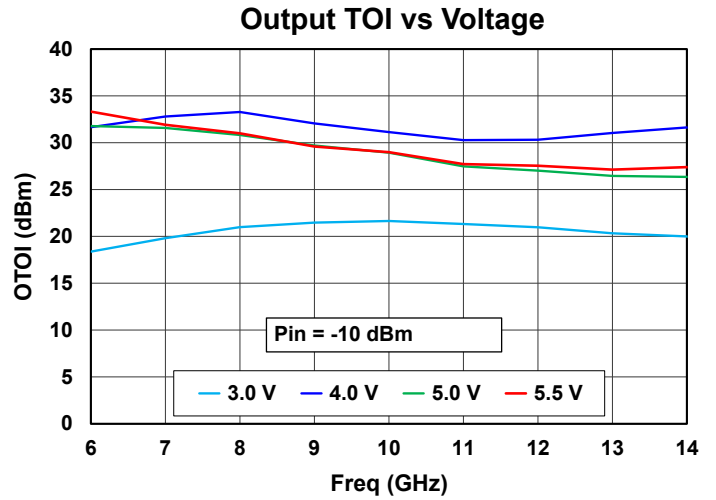
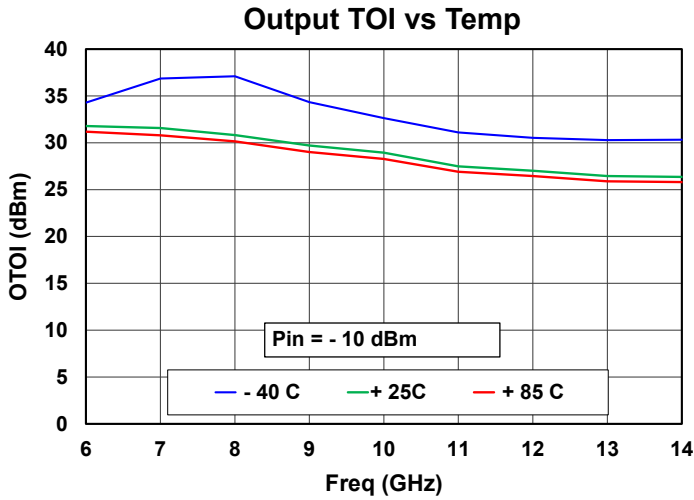

Application Circuit

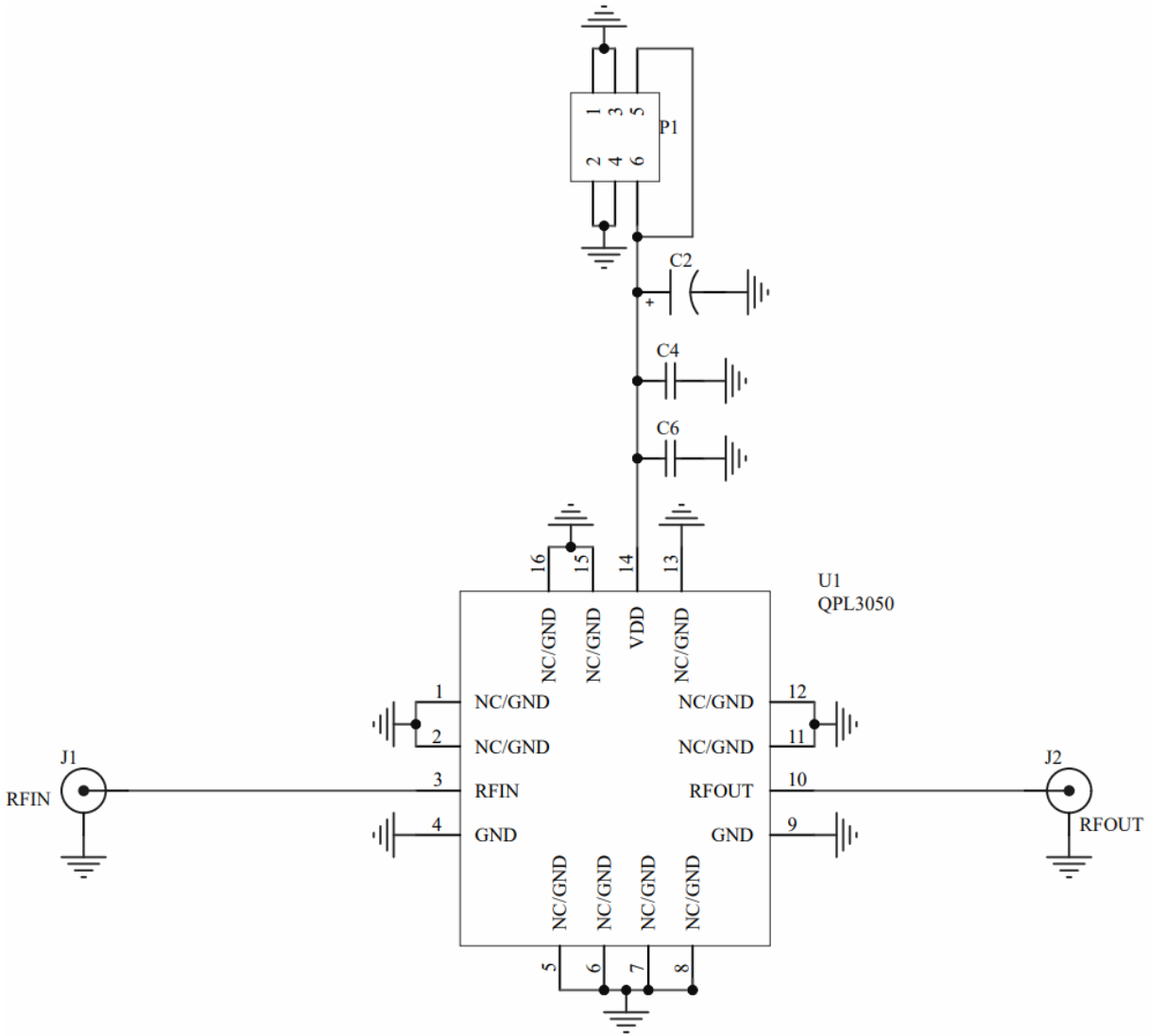

Bias-up Procedure

1. Not required

Bias-down Procedure

1. Not required

Evaluation Board and Assembly

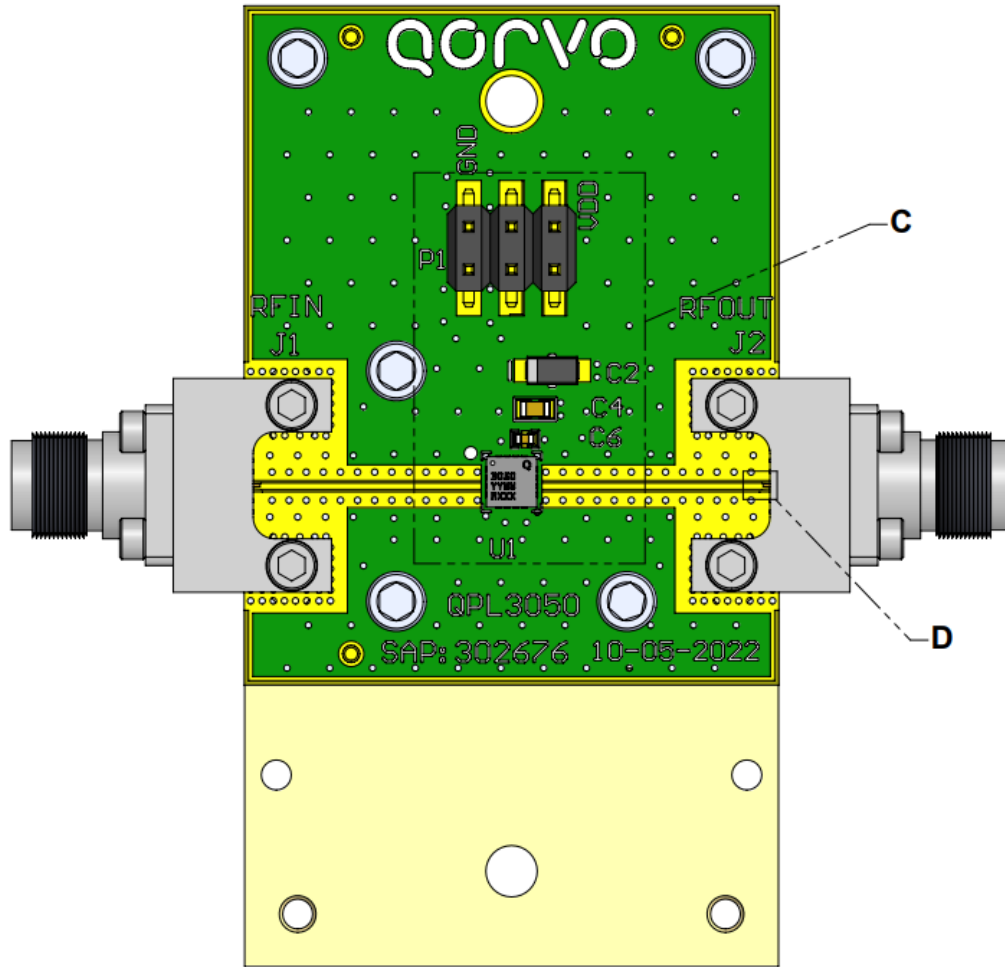

RF Layer is 0.010" thick Rogers Corp. RO4350. Metal layers are 0.5 oz. copper. The microstrip line at the connector interface is optimized for the Southwest Microwave end launch connector 1092-01A-5.

Bill of Materials

Ref. Des.	Component	Value	Manuf.	Part Number
C2	Surface Mount Cap.	CAP 0.33 uF, +/-20%, 25V, 1206 Tant, ROHS	Various	
C4	Surface Mount Cap.	CAP 1000 pF +/-10%, 25V, 0603, X7R, ROHS	Various	
C6	Surface Mount Cap.	CAP 100 pF, +/-5%, 25V, 0402, C0G, ROHS	Various	
J1, J2	RF Connector	2.92 mm RF CONNECTOR	Southwest Microwave	1092-01A-5

Mechanical Drawing & Pad Description

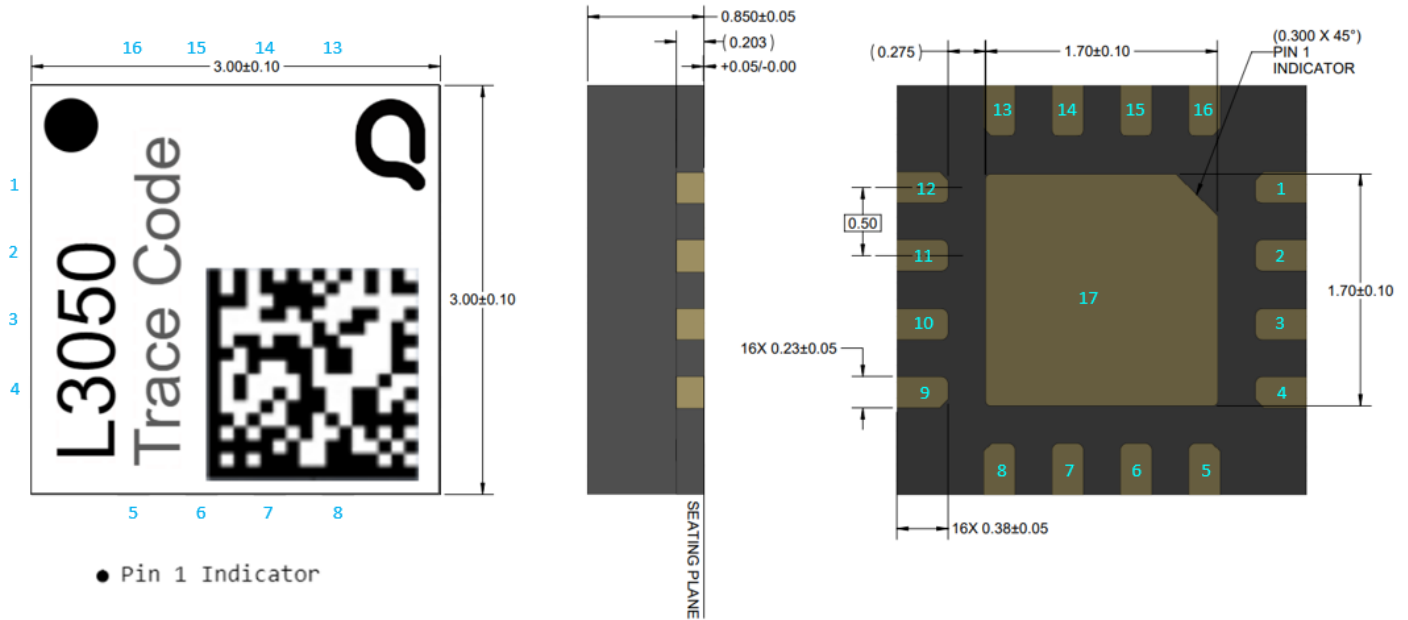

Dimensions in mm,
Package is mold encapsulated with NiPdAu plated leads,
Part Marking: Trace Code and 2DID can be used to trace part manufacturing information

Pin Number	Label	Description
4, 9, 17 (slug)	GND	GROUND
3	RFIN	Matched to 50 ohms, DC blocked
10	RFOUT	Matched to 50 ohms, DC blocked
14	VDD	Drain power supply
1, 2, 5 - 8, 11 – 13, 15, 16	N/C	No internal connections can be grounded

Thermal and Reliability Information

Parameter	Test Conditions	Value	Units
Thermal Resistance (θ_{JC}) ⁽¹⁾	$T_{base} = 85^{\circ}\text{C}$, $V_D = 5\text{ V}$, $I_{DQ} = 74\text{ mA}$	131.0	$^{\circ}\text{C/W}$
Channel Temperature (T_{CH})	Quiescent / Small Signal operation	133.5	$^{\circ}\text{C}$
Median Lifetime (T_M)	$P_{DISS} = 0.37\text{ W}$	9.7E06	Hrs

Notes:

- Thermal resistance is referenced to back of the package.

Median Lifetime

Test Conditions: $V_D = 4\text{ V}$
Failure Criteria = 10% reduction in I_{D_MAX}

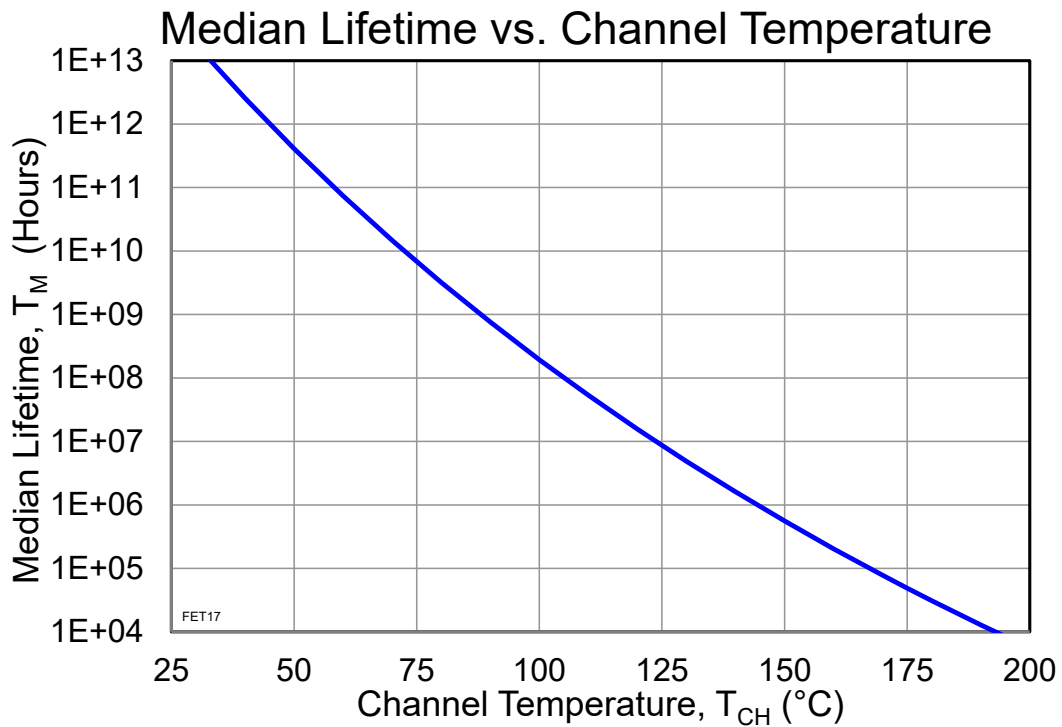

Solderability

- Compatible with the latest version of J-STD-020, lead-free solder, 260 °C peak reflow temperature.

Recommended Soldering Temperature Profile

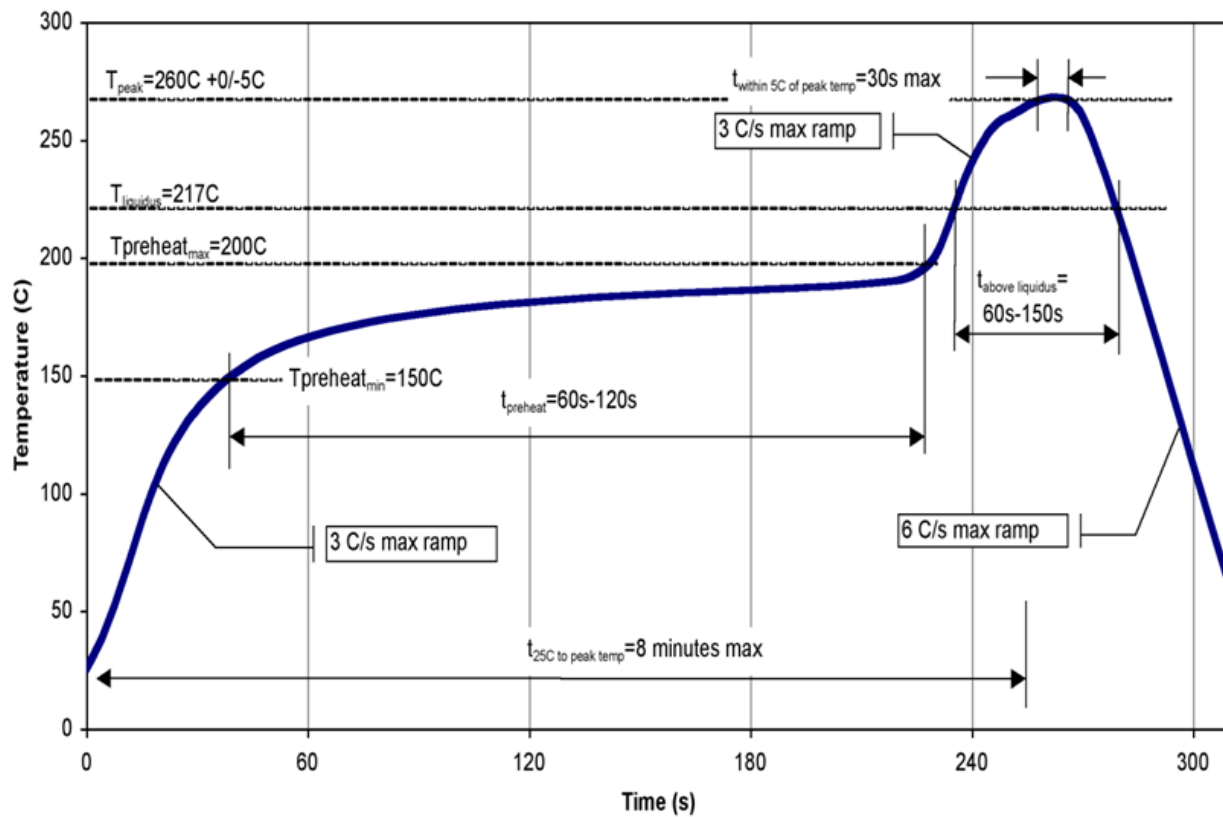

Handling Precautions

Parameter	Rating	Standard
ESD – Human Body Model (HBM)	1B	ESDA / JEDEC JS-001-2012
ESD – Charged Device Model (CDM)	C2b	ESDA / JEDEC JS-002-2014
MSL – Convection Reflow 260 °C	3	JEDEC standard IPC/JEDEC J-STD-020



Caution!
ESD-Sensitive Device

RoHS Compliance

This product is compliant with the 2011/65/EU RoHS directive (Restrictions on the Use of Certain Hazardous Substances in Electrical and Electronic Equipment), as amended by Directive 2015/863/EU.

This product also has the following attributes:

- Lead Free
- Halogen Free (Chlorine, Bromine)
- Antimony Free
- TBBP-A (C₁₅H₁₂Br₄O₂) Free
- SVHC Free
- PFOS Free

Contact Information

For the latest specifications, additional product information, worldwide sales and distribution locations:

Tel: 1-844-890-8163

Web: www.qorvo.com

Email: customer.support@qorvo.com

For technical questions and application information: **Email:** appsupport@qorvo.com

Important Notice



The information contained herein is believed to be reliable; however, Qorvo makes no warranties regarding the information contained herein and assumes no responsibility or liability whatsoever for the use of the information contained herein. All information contained herein is subject to change without notice. Customers should obtain and verify the latest relevant information before placing orders for Qorvo products. The information contained herein or any use of such information does not grant, explicitly or implicitly, to any party any patent rights, licenses, or any other intellectual property rights, whether with regard to such information itself or anything described by such information. **THIS INFORMATION DOES NOT CONSTITUTE A WARRANTY WITH RESPECT TO THE PRODUCTS DESCRIBED HEREIN, AND QORVO HEREBY DISCLAIMS ANY AND ALL WARRANTIES WITH RESPECT TO SUCH PRODUCTS WHETHER EXPRESS OR IMPLIED BY LAW, COURSE OF DEALING, COURSE OF PERFORMANCE, USAGE OF TRADE OR OTHERWISE, INCLUDING THE IMPLIED WARRANTIES OF MERCHANTABILITY AND FITNESS FOR A PARTICULAR PURPOSE.**

Without limiting the generality of the foregoing, Qorvo products are not warranted or authorized for use as critical components in medical, life-saving, or life-sustaining applications, or other applications where a failure would reasonably be expected to cause severe personal injury or death.

Copyright 2023 © Qorvo, Inc. | Qorvo is a registered trademark of Qorvo, Inc.

Looking for pricing, stock, or lifecycle information?

Click below to explore more details on WIN SOURCE:

-  [View QPL3050TR7 on WIN SOURCE](#)
-  [Qorvo US Inc. Information](#)

Optimize Your Supply Chain with WIN SOURCE Solutions

-  Global Sourcing Solution
-  Obsolete Management
-  Cost Control Management
-  Shortage Management
-  Alternative Solution
-  Excess Inventory Management