



FLAT GAIN, HIGH DYNAMIC RANGE

# Monolithic Amplifier

## PGA-122-75+

75Ω 4 to 1500 MHz

### THE BIG DEAL

- High IP3, +43.2 dBm Typ. at 0.5 GHz
- Gain, 15.6 dB Typ. at 0.5 GHz
- High P1dB 73.1 dBmV Typ. at 0.5 GHz
- Low Noise Figure, 2.9 dB at 0.5 GHz
- Usable over 4-2000 MHz

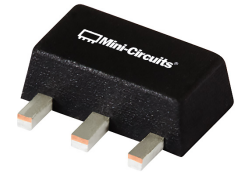

Generic photo used for illustration purposes only

CASE STYLE: DF782

### APPLICATIONS

- CATV, DOCSIS 3.1
- GPON
- MOCA
- DBS

#### +RoHS Compliant

The +Suffix identifies RoHS Compliance. See our website for methodologies and qualifications

### PRODUCT OVERVIEW

PGA-122-75+ (RoHS compliant) is an advanced wideband amplifier fabricated using E-pHEMT technology and offers extremely high dynamic range over a broad frequency range with low noise figure and flat gain. Lead finish is SnAgNi. It has repeatable performance from lot to lot and is enclosed in a SOT-89 package for very good thermal performance.

### KEY FEATURES

Feature	Advantages
Broad Band: 0.04 to 1.5 GHz	0.04 to 1.5 GHz bandwidth covers primary CATV applications such as DOCSIS 3.1
Application Circuit for 5 to 2000 MHz Available	Supports bandwidth requirements for upstream CATV applications. See application note AN-60-087. Recommend Evaluation Board, TB-885+
High IP3 Versus DC Power Consumption: +43 dBm Typical at 0.5 GHz	The PGA-122-75+ matches industry leading IP3 performance relative to device size and power consumption. The combination of the design and E-pHEMT structure provides enhanced linearity over a broad frequency range as evidence in the IP3 being typically 15-20 dB above the P1dB point. This feature makes this amplifier ideal for use in CATV applications.
High IP2, +54 dBm at 0.5 GHz	Suppresses second order product on wideband applications such as CATV
Low Noise Figure, 2.9 dB at 0.5 GHz	Low noise figure performance in combination with the high output IP3 results in high dynamic range.
Excellent CSO/CTB* CSO, -59 dBc CTB, -80 dBc Measured at channel 78	Competitive performance at lower current and supply voltage.

\* 78 channels flat, 30 dBmV/channel at output, 6 MHz channel spacing

REV. B  
ECO-024506  
PGA-122-75+  
MCL NY  
250212





FLAT GAIN, HIGH DYNAMIC RANGE

# Monolithic Amplifier

**PGA-122-75+**

Mini-Circuits

75Ω 4 to 1500 MHz

**ELECTRICAL SPECIFICATIONS AT +25°C, 75Ω AND 9 V<sup>1</sup> UNLESS NOTED OTHERWISE**

Parameter	Condition (GHz)	V <sub>D</sub> =+9 V			V <sub>D</sub> =+8 V	Units
		Min.	Typ.	Max.	Typ.	
Frequency Range		0.04		1.5	0.04-1.5	GHz
Gain	0.04	14.0	15.5	17.1	15.5	dB
	0.5		15.6		15.6	
	1.0		15.5		15.5	
	1.25		15.4		15.3	
	1.5		15.1		15.0	
Gain Flatness Over	0.04-1.25		±0.1		±0.1	dB
Input Return Loss	0.04		17.8		17.6	dB
	0.5		21.2		20.8	
	1.0		18.7		18.0	
	1.25		16.1		15.9	
	1.5		14.2		13.8	
Output Return Loss	0.04		19.8		20.2	dB
	0.5		24.3		24.1	
	1.0		16.4		16.7	
	1.25		13.0		13.0	
	1.5		10.0		9.8	
Reverse Isolation	1.0		21.0		21.0	dB
Output power @ 1 dB Compression	0.04		23.4 (72.2)		22.4 (71.2)	dBm (dBmV)
	0.5		24.3 (73.1)		23.3 (72.1)	
	1.0		23.8 (72.6)		23.1 (71.9)	
	1.25		23.3 (72.1)		22.3 (71.1)	
	1.5		22.8 (71.6)		21.6 (70.4)	
Output IP3	0.04		+43.3		+42.3	dBm
	0.5		+43.2		+43.6	
	1.0		+41.4		+39.9	
	1.25		+38.8		+37.0	
	1.5		+37.9		+35.4	
Output IP2 <sup>2</sup>	0.04		+59.5		+56.9	dBm
	0.5		+54.9		+53.0	
	1.0		+58.5		+57.5	
	1.25		+52.2		+50.1	
	1.5		+49.4		+47.2	
Noise Figure	0.04		2.9		3.0	dB
	0.5		2.9		2.8	
	1.0		2.8		2.9	
	1.25		3.0		2.9	
	1.5		3.0		3.2	
Device Operating Voltage		+8.5	+9.0	+9.5	+8.0	V
Device Operating Current			115	140	102	mA
Device Current Variation vs. Temperature <sup>3</sup>			22		25	μA/°C
Device Current Variation vs. Voltage			0.0146		0.0146	mA/mV
Thermal Resistance, Junction-to-Ground Lead			30		30	°C/W

1. Measured on Mini-Circuits Characterization Eval board TB-859+. See Characterization Test Circuit (Fig. 1).
2. Output IP2 measured at sum frequency of the two tones (f meas= f1 + f2).
3. (Current at +85°C - Current at -45°C)/130

**ABSOLUTE MAXIMUM RATINGS<sup>4</sup>**

Parameter	Ratings
Operating Temperature (Ground Lead)	-40°C to +85°C
Storage Temperature	-65°C to +150°C
Operating Current at +9.0 V	167 mA
Power Dissipation	1.5 W
Input Power (CW)	+20 dBm over 40-1200 MHz, and +24 dBm over 1200-1500 MHz (5 minutes) +17 dBm over 40-1200 MHz, and +20 dBm over 1200-1500 MHz (continuous)
DC Voltage on Pin 3	+11 V

4. Permanent damage may occur if any of these limits are exceeded. Electrical maximum ratings are not intended for continuous normal operation.





FLAT GAIN, HIGH DYNAMIC RANGE

# Monolithic Amplifier

## PGA-122-75+

Mini-Circuits

75Ω 4 to 1500 MHz

### SIMPLIFIED SCHEMATIC AND PIN DESCRIPTION

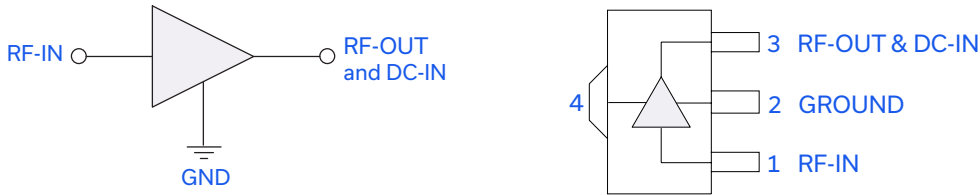

Function	Pin Number	Description
RF-IN	1	RF input pin. This pin requires the use of an external DC blocking capacitor chosen for the frequency of operation.
RF-OUT and DC-IN	3	RF output and bias pin. DC voltage is present on this pin; therefore a DC blocking capacitor is necessary for proper operation. An RF choke is needed to feed DC bias without loss of RF signal due to the bias connection, as shown in "Recommended Application Circuit", Fig. 2.
GND	2,4	Connections to ground. Use via holes as shown in "Suggested Layout for PCB Design" to reduce ground path inductance for best performance.



FLAT GAIN, HIGH DYNAMIC RANGE

# Monolithic Amplifier

## PGA-122-75+

Mini-Circuits

75Ω 4 to 1500 MHz

### CHARACTERIZATION TEST CIRCUIT

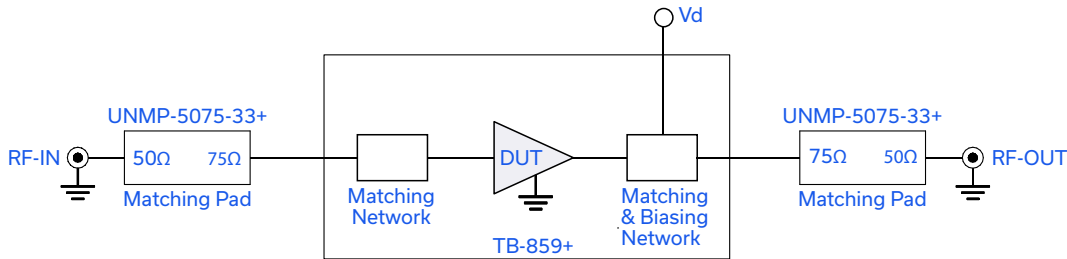
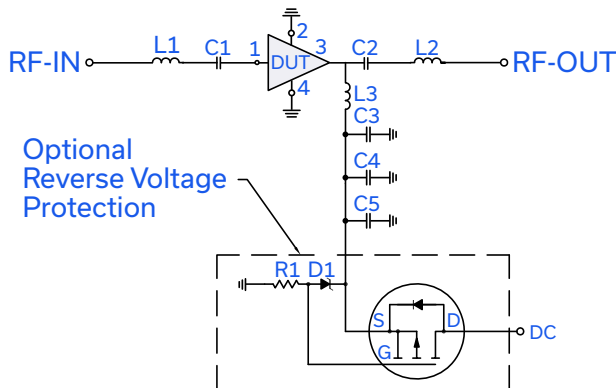

Fig 1. Block Diagram of Test Circuit used for characterization. (DUT tested on Mini-Circuits Characterization Eval board TB-859+.) Gain, Return Loss, Output Power at 1 dB Compression (P1dB), Output IP3 (OIP3), Output IP2 (OIP2) and Noise Figure measured using Agilent's N5242A PNA-X microwave network analyzer.

Conditions:

1. Gain and Return loss:  $P_{IN} = -25$  dBm
2. Output IP3 (OIP3): Two tones, spaced 1 MHz apart, +5 dBm/tone at output.
3. Output IP2 (OIP2): Two tones, spaced 11 MHz apart, +5 dBm/tone at output.

### RECOMMENDED APPLICATION CIRCUIT (TB-850+)



COMPONENT	VALUE	SIZE
DUT	PGA-122-75+	—
C1	1000 pF	0402
C2	120 pF	
C3	100 pF	
C4	10000 pF	
C5	10 uF, 25V	1206
D1	Zener Diode 5.6V ONSEMI MMSZ4690T1G	SOD123
L1	3.3 nH	0402
L2	4.7 nH	0603
L3	560 nH	
R1	1.5 kOhm	SOT323
Q1	Transistor ONSEMI FET NTS4101P	

Fig 2. Evaluation board includes case, connectors, and components soldered to PCB  
Note: R1, D3 and Q1 are for reverse voltage protection and may be omitted.

### PRODUCT MARKING

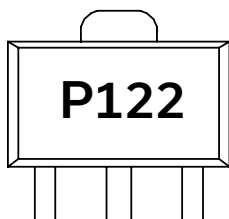

Marking may contain other features or characters for internal lot control.

Mini-Circuits



FLAT GAIN, HIGH DYNAMIC RANGE

# Monolithic Amplifier

## PGA-122-75+

Mini-Circuits

75Ω 4 to 1500 MHz

ADDITIONAL DETAILED TECHNICAL INFORMATION IS AVAILABLE ON OUR DASHBOARD. [CLICK HERE](#)

Performance Data	Data Table
	Swept Graphs
	S-Parameter (S2P Files) Data Set (.zip file)
5-200 MHz Operation	See Application Note AN-60-087
Case Style	DF782 (SOT 89) Plastic package, exposed paddle lead finish: tin-silver over nickel
Tape & Reel	F477
Suggested Layout for PCB Design	PL-477
Evaluation Board	TB-850+ (40-1500 MHz) TB-885+ (5-20 MHz)
Environmental Ratings	ENV08T1

### ESD RATING

Human Body Model (HBM): Class 1A (250 <500 V) in accordance with ANSI/ESD STM 5.1 - 2001

Machine Model (MM): Class class M1 (25 V) in accordance with ANSI/ESD STM5.2-1999

### MSL RATING

Moisture Sensitivity: MSL1 in accordance with IPC/JEDEC J-STD-020D

#### NOTES

- A. Performance and quality attributes and conditions not expressly stated in this specification document are intended to be excluded and do not form a part of this specification document.
- B. Electrical specifications and performance data contained in this specification document are based on Mini-Circuit's applicable established test performance criteria and measurement instructions.
- C. The parts covered by this specification document are subject to Mini-Circuits standard limited warranty and terms and conditions (collectively, "Standard Terms"); Purchasers of this part are entitled to the rights and benefits contained therein. For a full statement of the standard terms and the exclusive rights and remedies thereunder, please visit Mini-Circuits' website at [www.minicircuits.com/terms/viewterm.html](http://www.minicircuits.com/terms/viewterm.html)



## Looking for pricing, stock, or lifecycle information?

Click below to explore more details on WIN SOURCE:

 [View PGA-122-75+ on WIN SOURCE](#)

 [Mini-Circuits Information](#)

## Optimize Your Supply Chain with WIN SOURCE Solutions

-  Global Sourcing Solution
-  Obsolete Management
-  Cost Control Management
-  Shortage Management
-  Alternative Solution
-  Excess Inventory Management